

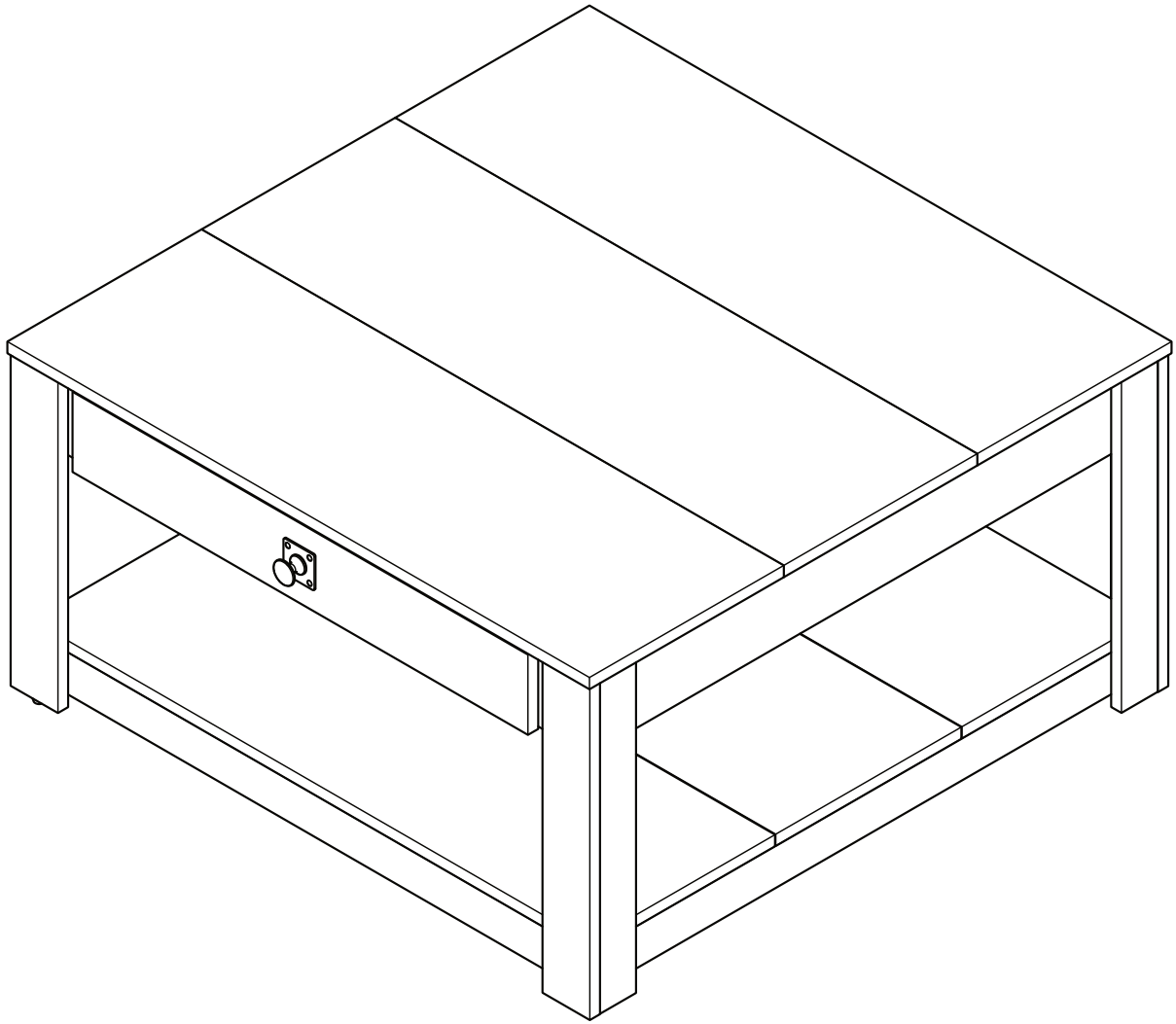

**ASSEMBLY INSTRUCTIONS / INSTRUCTIONS
D'ASSEMBLAGE / INSTRUCTIVO DE ARMADO**





FG-RB/IY/KO/DI-PU-16-935-AMS

NOTES ON ASSEMBLY / NOTES POUR L'ASSEMBLAGE / NOTAS SOBRE EL ENSAMBLE

- To ensure ease of assembly read all instructions before assembly and follow step by step illustrations.
- Keep instructions for future use.
- Adult assembly required.  2 person required. 
- Due to the presence of small parts during assembly, keep out of reach of children until assembly is complete.

- Pour assurer l'assemblage facile veuillez lire toutes les instructions avant l'assemblage et veuillez suivre les illustrations pour chaque étapes.
- Veuillez garder ces instructions pour l'usage ulterieur.
- Assemblage requis pas un adulte.  2 personnes requises. 
- Due a la presence de petite pieces durant l'assemblage, veuillez garder hors de porter des enfants jusqu'a ce que l'assemblage soit completer.

- Para garantizar la facilidad de ensamble lea las instrucciones antes de iniciar y siga paso a paso las ilustraciones.
- Guarde las instrucciones para futuras referencias.
- El ensamble requiere de un adulto.  2 personas requeridas. 
- Debido a que hay piezas pequeñas, mantenga fuera del alcance a los niños durante el ensamble, hasta que haya terminado.

MAINTENANCE TIPS / CONSEILS D'ENTRETIEN / CONSEJOS DE MANUTENIMIENTO

- Never let liquids or damp cloths sit on this furniture.
- Never use chemical cleaning products. They can damage the finish. For cleaning, use only a slightly damp cloth and wipe dry.
- To avoid dulling of the finish, do not place furniture in direct sunlight.
- Do not put plastic or rubber rings under appliances. Use cloth of felt protectors.
- To clean, use a soft or slightly damp cloth, then wipe with a clean, dry cloth.

- Ne jamais laisser de liquide ou linge humide sur le meuble.
- Ne jamais utiliser de nettoyeurs à base de produits chimiques, cela va endommager le fini. Utiliser seulement un linge légèrement humide.
- Ne pas placer le meuble directement au soleil pour prévenir le ternissement.
- Évitez de déposer des appareils avec des rondelles de plastique ou de caoutchouc. Utilisez un protecteur en tissu ou en feutre.
- Pour nettoyer, utilisez un linge doux ou légèrement humecté. Essayez par la suite avec un linge propre et sec.

- Nunca deje un líquido o un trapo húmedo sobre el mueble.
- Nunca utilice limpiadores a base de químicos, estos dañaran le acabado. Use sólo un paño húmedo.
- No esponga el mueble directamente al sol para prevenir empañamiento.
- Evite apoyar aparatos con redondeles de plástico o de goma. Utilizar un protector de tela o de fieltro.
- Para limpiar, utilice un trapo suave o ligeramente humedecido. Seque luego con un trapo limpio y seco.

WARNING AVERTISSEMENT / ADVERTENCIA

Please use your furniture correctly and safely. Improper use can cause safety hazards, or damage to your furniture or household items.

- Placing TV on furniture items that are not designed to support a television is hazardous.
- Top-heavy furniture can tip over.
- Work from bottom to top when loading shelves and drawers. Place the heaviest items on the lower shelves or in lower drawers.
- Overloaded shelves or drawer can break.
- This product is not designed to support a television.
- Risk of injury or death. TVs can be very heavy. Plus the weight and location of the picture tube tends to make TVs unbalanced and prone to tipping forward.

Prière d'utiliser le mobilier à bon escient et avec prudence. Une mauvaise utilisation peut être à l'origine de risques d'accident ou peut endommager le mobilier et les articles ménagers.

- Il est dangereux de placer des téléviseurs sur des meubles que ne sont pas prévus à cet effet.
- Du mobilier mal équilibré risque de se renverser.
- Commencer à charger les tablettes et tiroirs à partir du bas et finir au haut. Placer les objets les plus lourds sur les tablettes inférieures ou dans les tiroirs inférieurs.
- Des tiroirs surchargés peuvent casser.
- Ce produit n'est pas destiné à supporter un téléviseur.
- Risque de blessures graves, voire mortelles. Les téléviseurs peuvent être particulièrement lourds. De plus, le poids et l'emplacement du tube image ont tendance à rendre les téléviseurs instables et enclins à tomber vers l'avant.

Por favor use el mobiliario correcta y seguramente. El mal uso puede causar riesgos de seguridad o daño a las unidades o artículos domésticos.

- Es peligroso colocar los televisores sobre muebles que no están diseñados para soportar un televisor.
- El mobiliario inestable puede volcarse.
- Para cargar los estantes y cajones, comience al fondo y termine en la parte superior. Coloque los artículos más pesados sobre los estantes inferiores o en los cajones inferiores.
- Los cajones o estantes sobrecargados pueden romperse.
- Este producto no está diseñado para soportar un televisor. Un riesgo de lesiones o la muerte. Los televisores pueden ser muy pesados. Además, el peso y la ubicación del tubo de imagen tienden a causar la inestabilidad de televisores y son propensos a inclinarse hacia adelante.

MINIFIX CAM & MINIFIX BOLT
CAMÉRA MINIFIX & BOULON MINIFIX
CÁMARA MINIFIX & PERNO MINIFIX

MINIFIX BOLT
BOULON MINIFIX
PERNO MINIFIX



MINIFIX CAM
CAMÉRA MINIFIX
CÁMARA MINIFIX

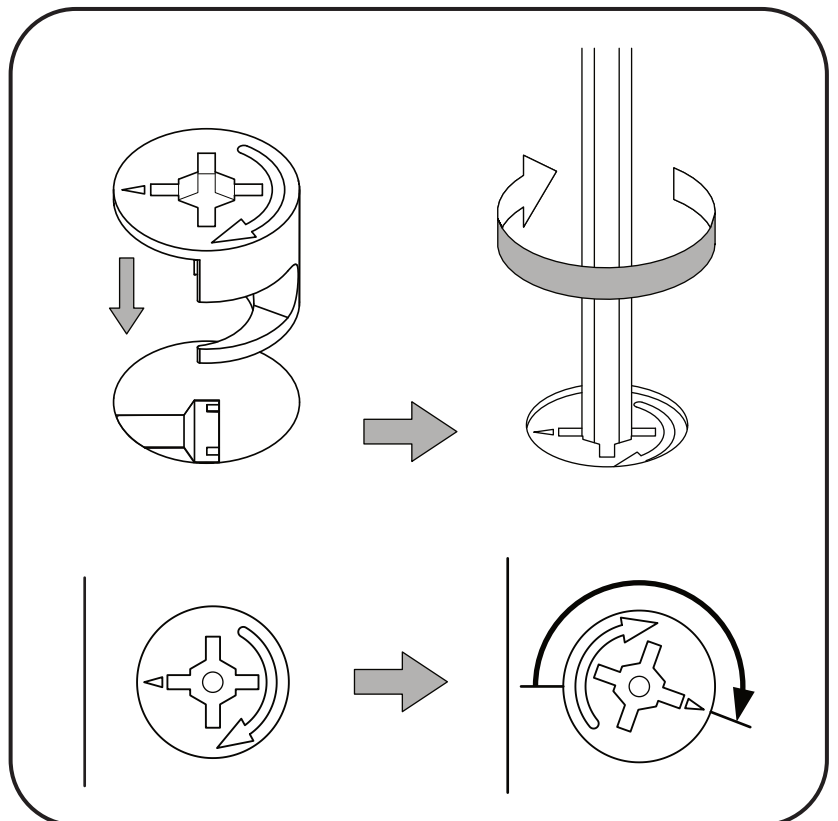

SPECIAL TIPS FOR FITTING DRAWER CONSEJOS ESPECIALES PARA EL MONTAJE DEL CAJÓN CONSEILS SPÉCIAUX POUR LE MONTAGE DU TIROIR

DRAWER RUNNER - A

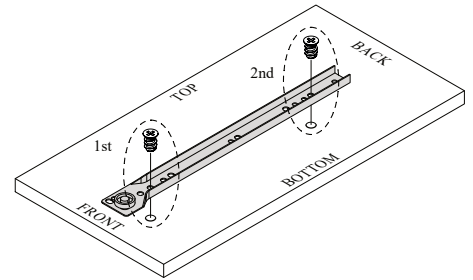
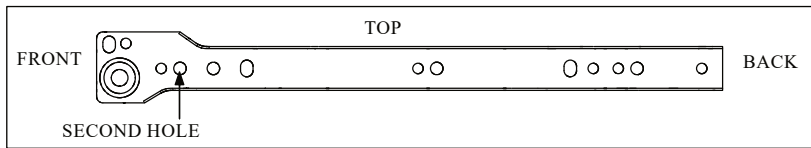

- Fix the first screw on the second hole on drawer runner as shown.
Fije el primer tornillo en el segundo orificio de la guía del cajón como se muestra
Fixez la première vis sur le deuxième trou de la glissière du tiroir comme indiqué
- Fix the second screw following the holes on panel.
Fije el segundo tornillo siguiendo los agujeros en el panel
Fixez la deuxième vis en suivant les trous sur le panneau

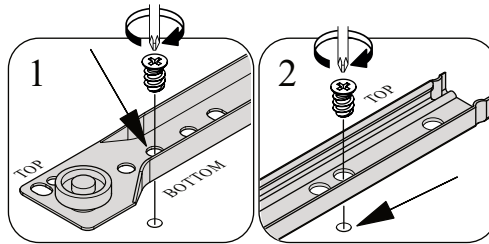

- Ensure the position of the drawer runner is correct as showed above.
Asegúrese de que la posición de la guía del cajón sea la correcta, como se muestra arriba.
Assurez-vous que la position de la glissière du tiroir est correcte comme indiqué ci-dessus.

DRAWER RUNNER - B

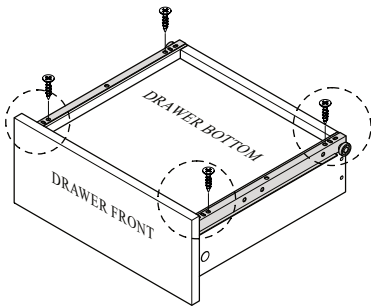
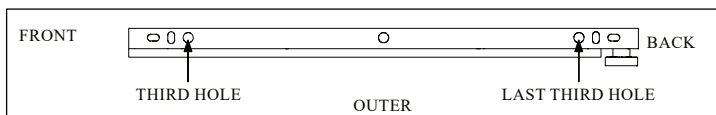

- Ensure the position of the drawer runner is correct as showed above.
Asegúrese de que la posición de la guía del cajón sea la correcta, como se muestra arriba.
Assurez-vous que la position de la glissière du tiroir est correcte comme indiqué ci-dessus.

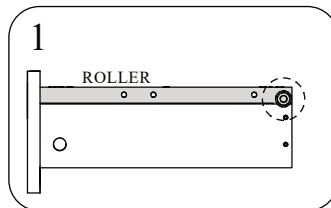

- Push the runner to drawer front.
Empuje la guía hasta el frente del cajón.
Poussez la glissière vers l'avant du tiroir.

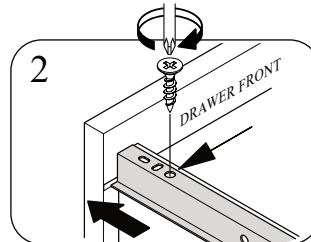

- Fix the first screw on the third hole from front.
Fije el primer tornillo en el tercer orificio desde el frente.
Fixez la première vis sur le troisième trou à partir de l'avant.

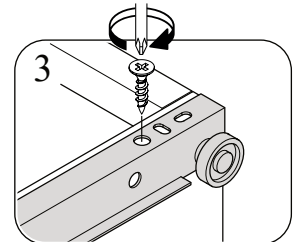

- Fix the second screw on the last third hole.
Fije el segundo tornillo en el último tercer orificio.
Fixez la deuxième vis sur le dernier troisième trou

INSTALL DRAWER TO CABINET / INSTALE EL CAJÓN AL GABINETE / INSTALLER LE TIROIR SUR L'ARMOIRE

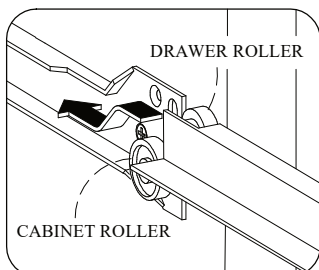

- Locate both roller on drawer box and roller on cabinet.
Ubique tanto el rodillo en la caja del cajón como el rodillo en el gabinete.
Localisez à la fois le rouleau sur la boîte à tiroirs et le rouleau sur l'armoire

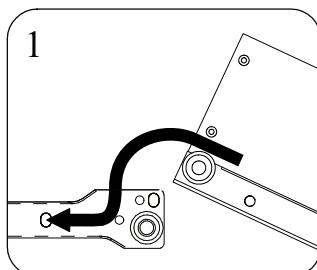

- Align the roller on drawer box on top of the roller on cabinet.
Alinee el rodillo en la caja del cajón en la parte superior del rodillo en el gabinete.
Alignez le rouleau sur la boîte à tiroirs sur le dessus du rouleau sur l'armoire.

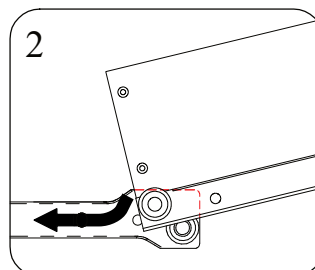



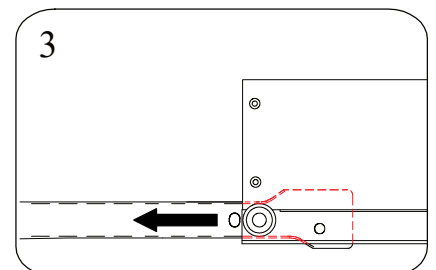



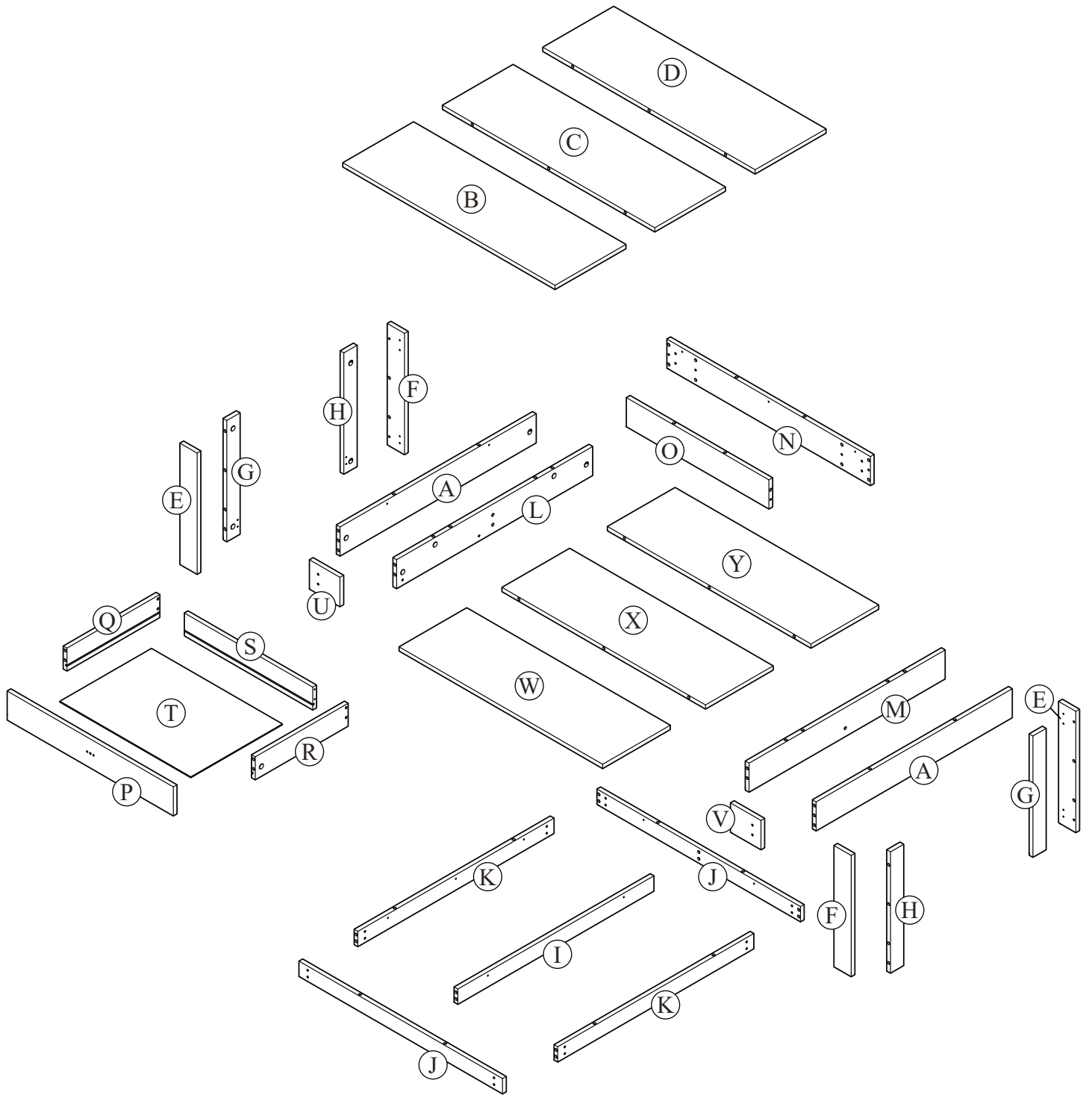





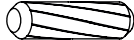
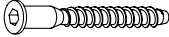

- Push inside the drawer box.
Empuje dentro de la caja del cajón.
Poussez à l'intérieur de la boîte à tiroirs

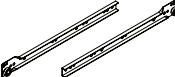
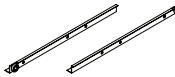

- Ensure the roller is in the track of drawer slide before push to the end.
Asegúrese de que el rodillo esté en el riel de la corredera del cajón antes de empujarlo hasta el final.
Assurez-vous que le rouleau est dans le rail de la glissière du tiroir avant de pousser jusqu'au bout.



HARDWARE QUINCAILLERIE / HERRAJE



(A)	Minifix Bolt EU 24  22 units	(B)	Minifix Cam 15/9.5  22 units	(C)	Dowel M8 x 30mm  70 + 2 units
(D)	Unita M6.3 x 50mm  2 units	(E)	Screw M3.5 x 15mm  50 + 2 units	(F)	Screw M4 x 38mm  4 units
(G)	Screw M6 x 8mm  4 units	(H)	PVC L Bracket  23 units	(I)	Nail Leg 5/8"  8 units
(J)	Screw #8 x 25mm  24 units	(K)	Drawer Slide 350mm  1 set	(L)	Drawer Slide 350mm  1 set
(M)	Back Ply Stopper  2 units	(N)	Kazo Handle  1 unit	(O)	Screw M4 x 30mm  1 unit
(P)	Screw M3.1 x 20mm  2 units	(Q)	Allen Key Z M4  1 unit		

- Hardware quantity may supplied more than it required. Please keep spares and tools for future use.
- La cantidad de hardware puede suministrarse más de lo requerido. Guarde los repuestos y las herramientas para uso futuro.
- La quantité de matériel peut fournir plus que nécessaire. Veuillez conserver les pièces de rechange et les outils pour une utilisation future.

TOOLS NOT INCLUDED OUTILS PAS INCLUS / HERRAMIENTAS NO INCLUIDAS



STEP 1

	
E x 12	H x 12

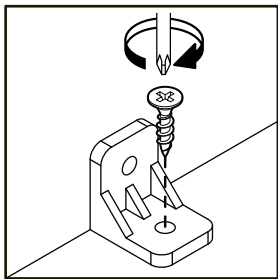
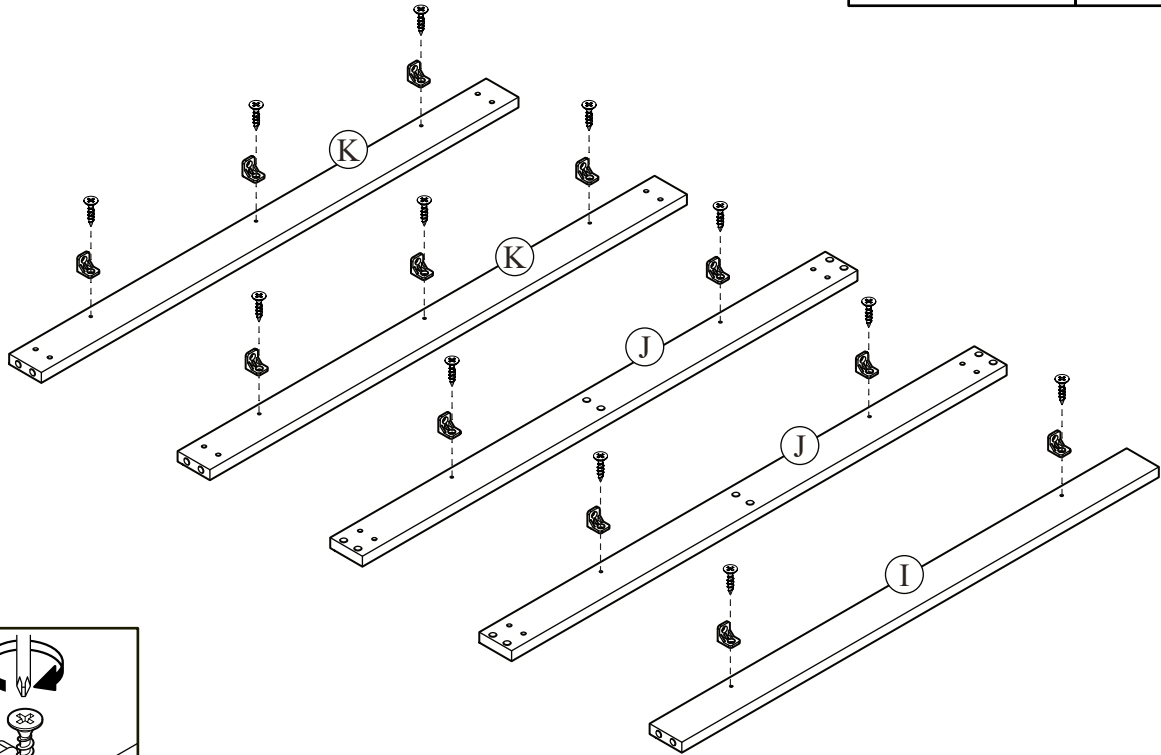

STEP 2

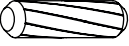

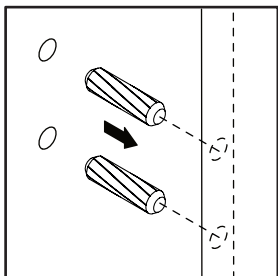
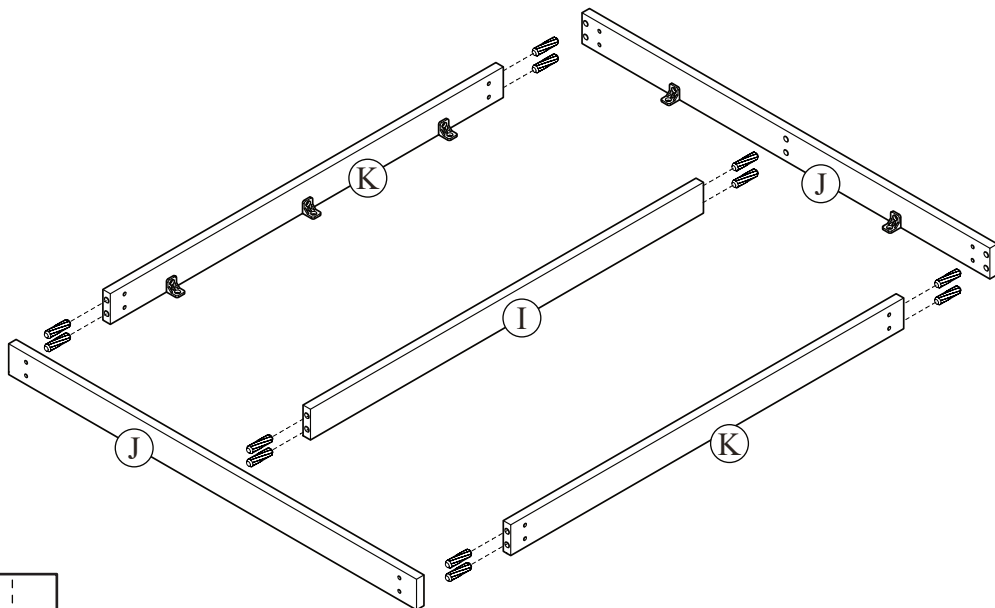
C x 12

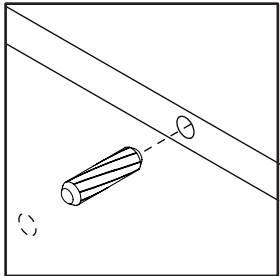
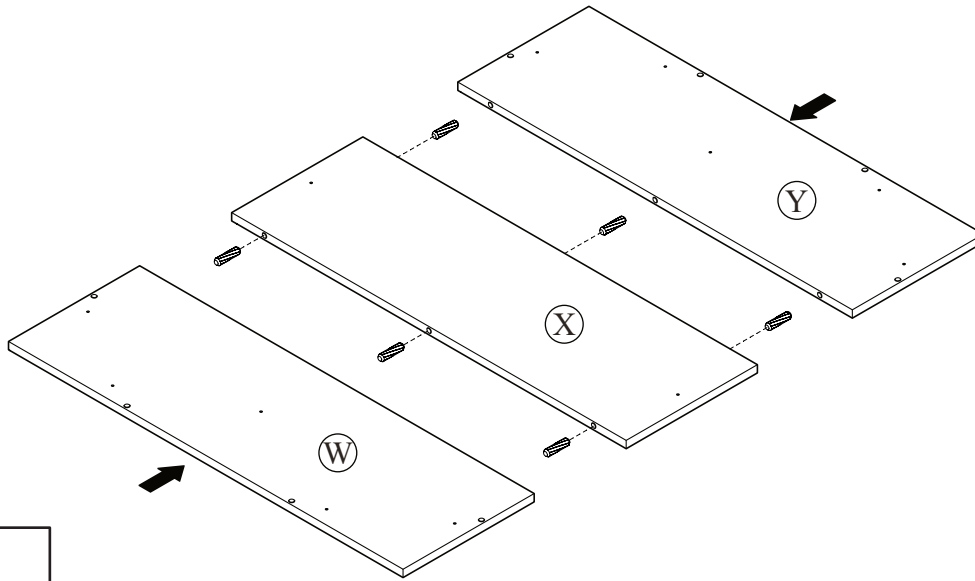
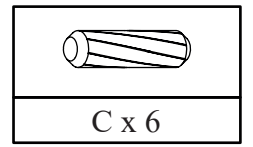

STEP 3

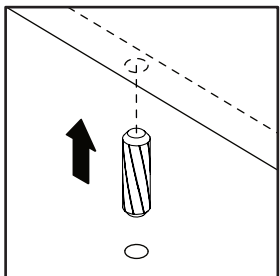
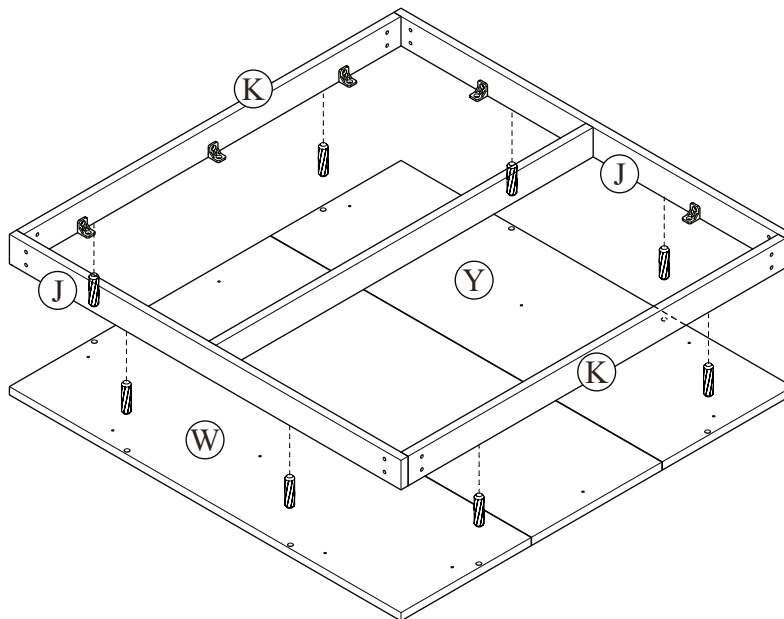
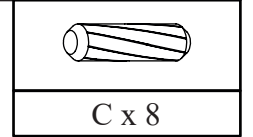

STEP 4



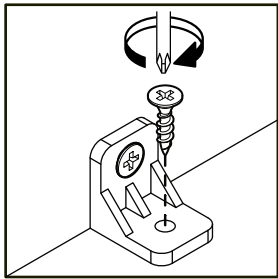
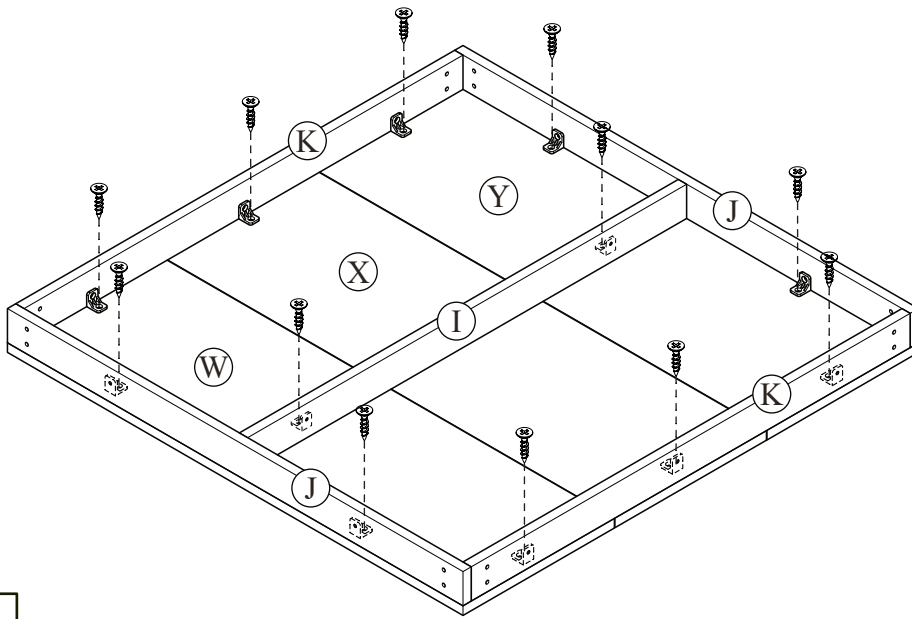

STEP 5

E x 12



STEP 6

	
E x 11	H x 11

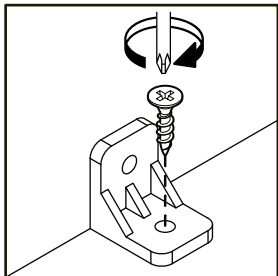
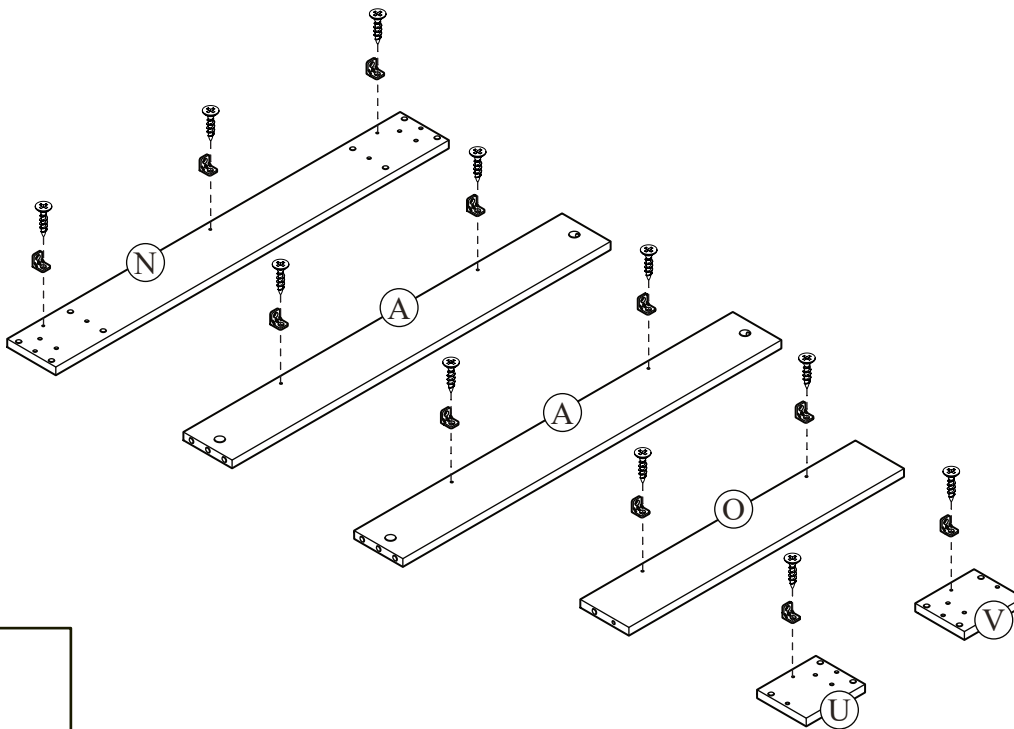

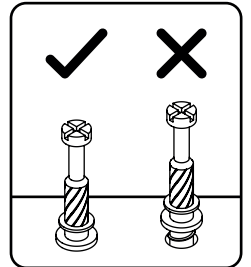
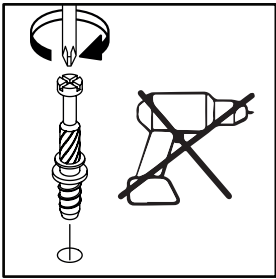
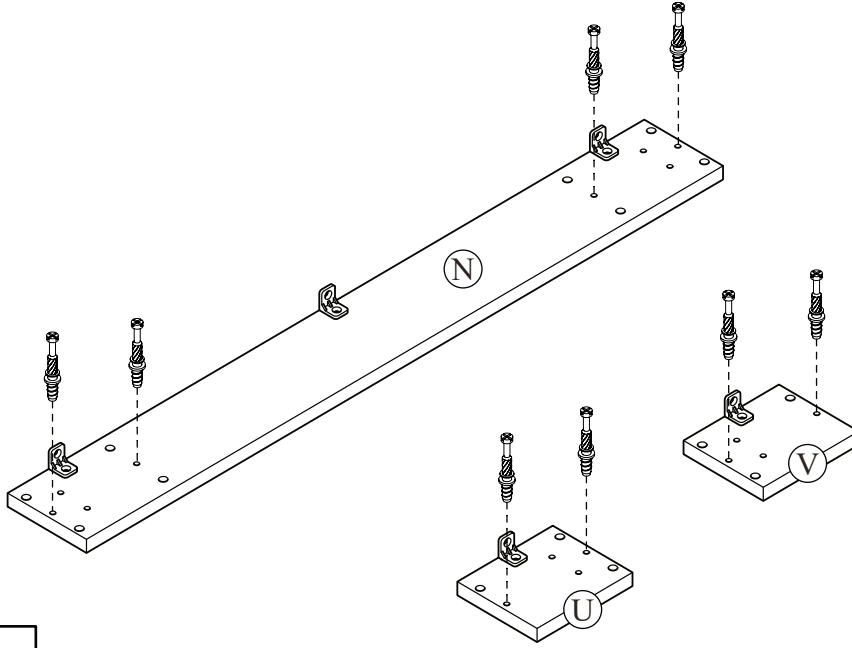
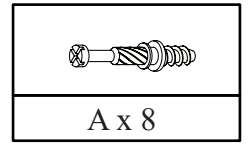

STEP 7

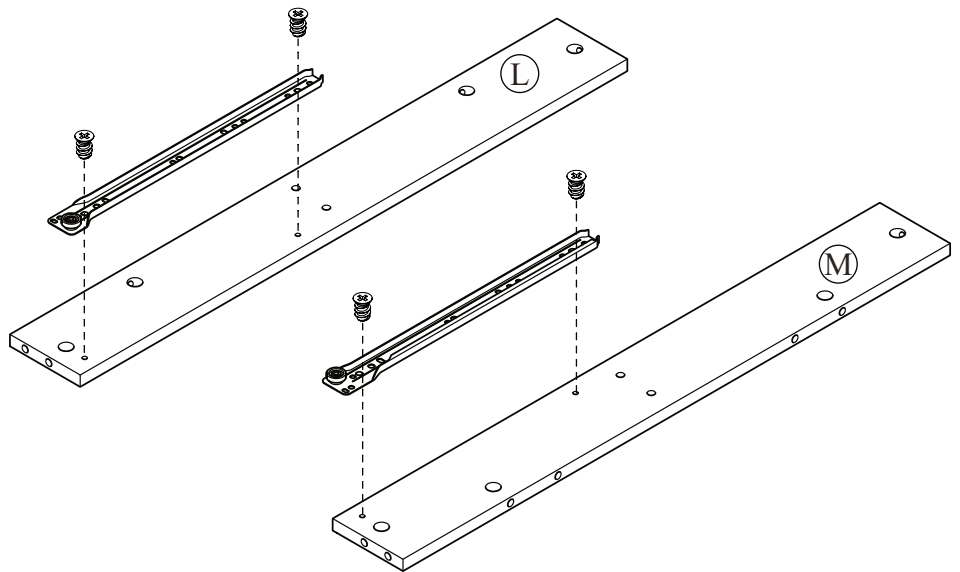
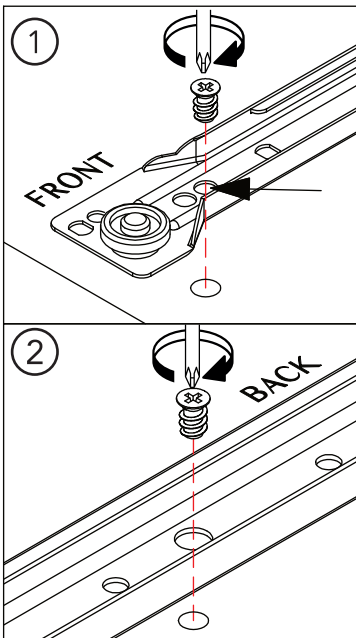
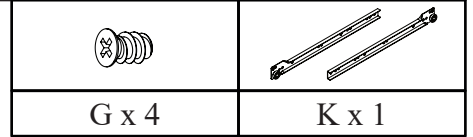

STEP 8

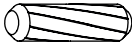

STEP 9

	
C x 2	D x 2

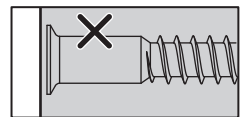
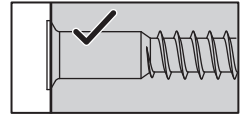
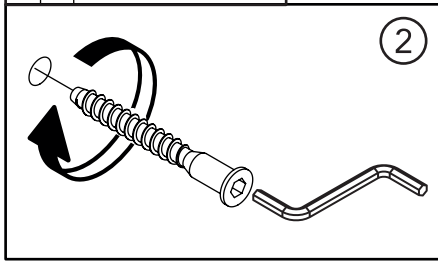
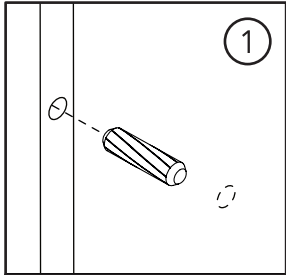
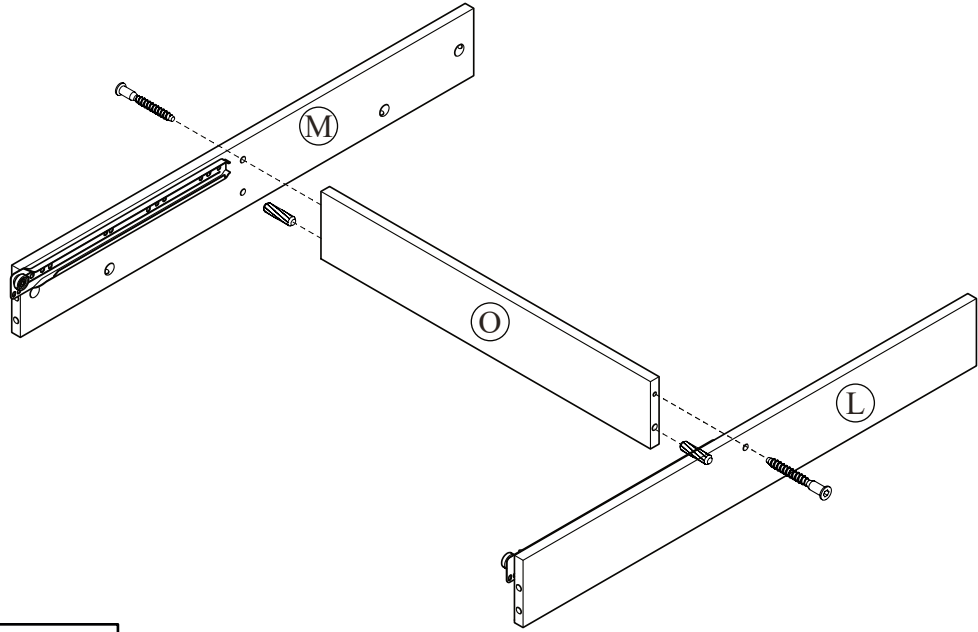

STEP 10

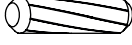

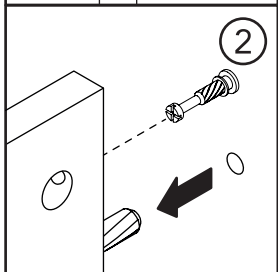
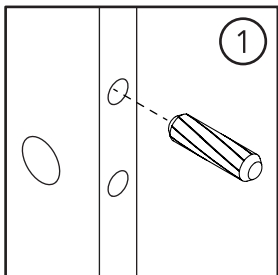
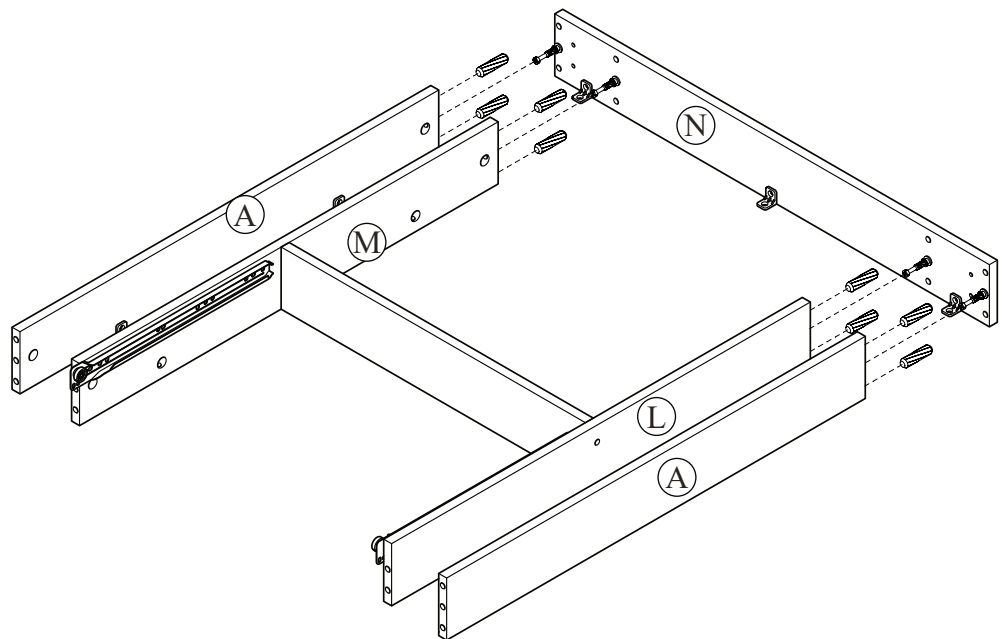
C x 8

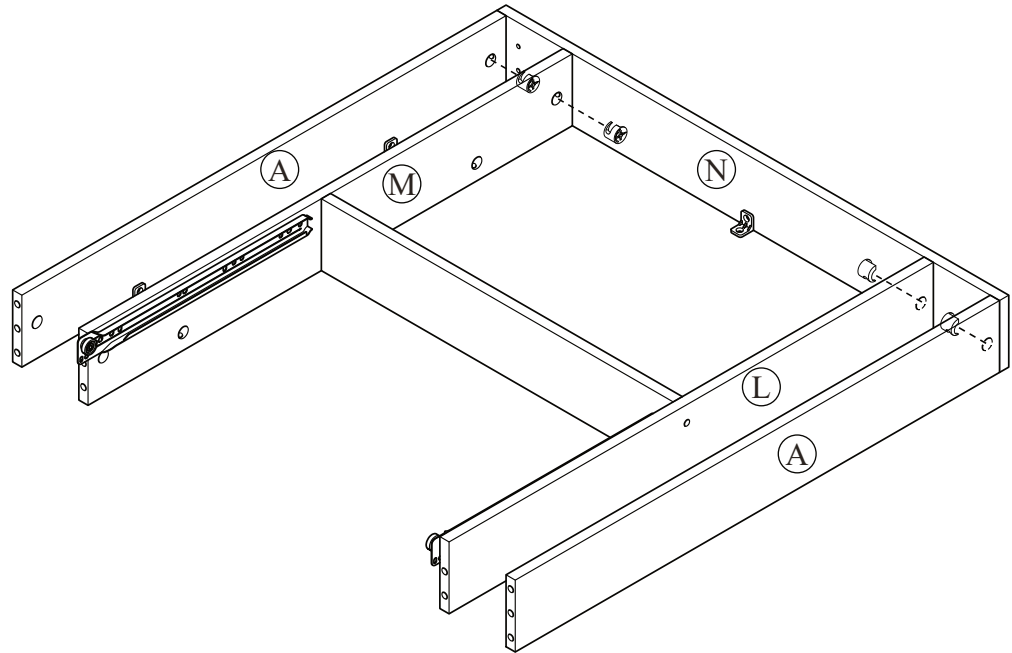
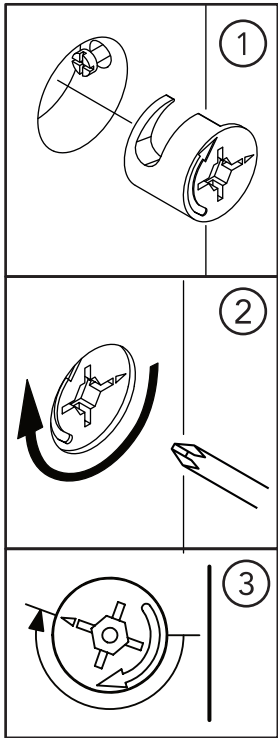
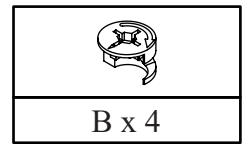

STEP 11

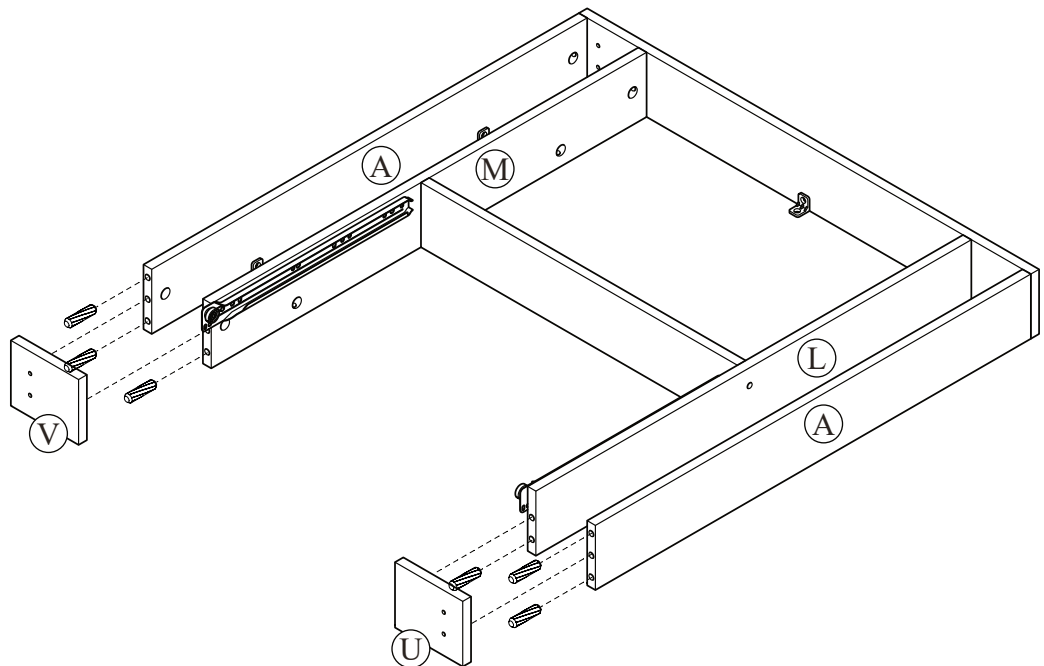
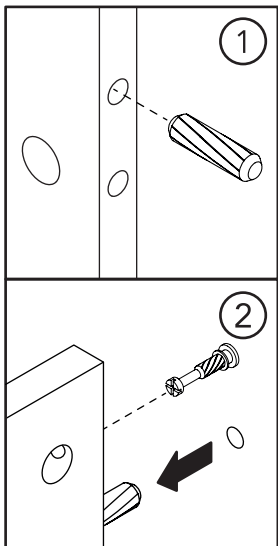
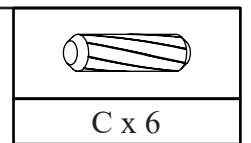

STEP 12



STEP 13

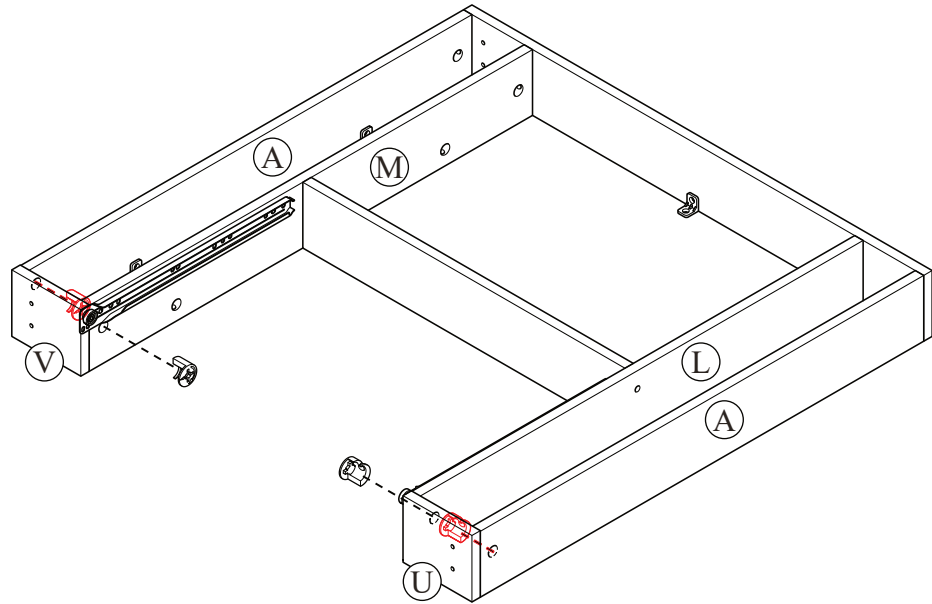
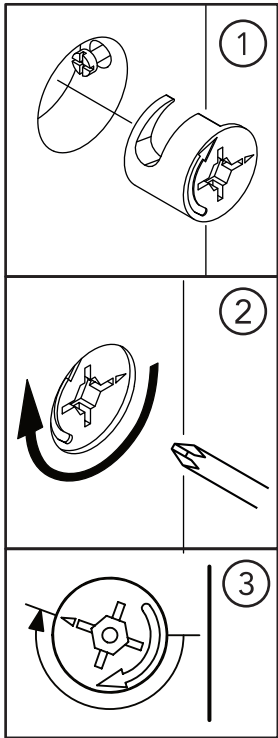
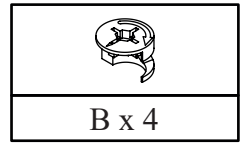

STEP 14

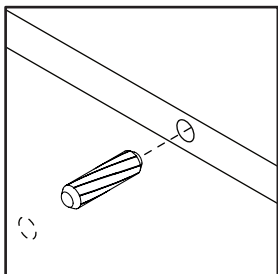
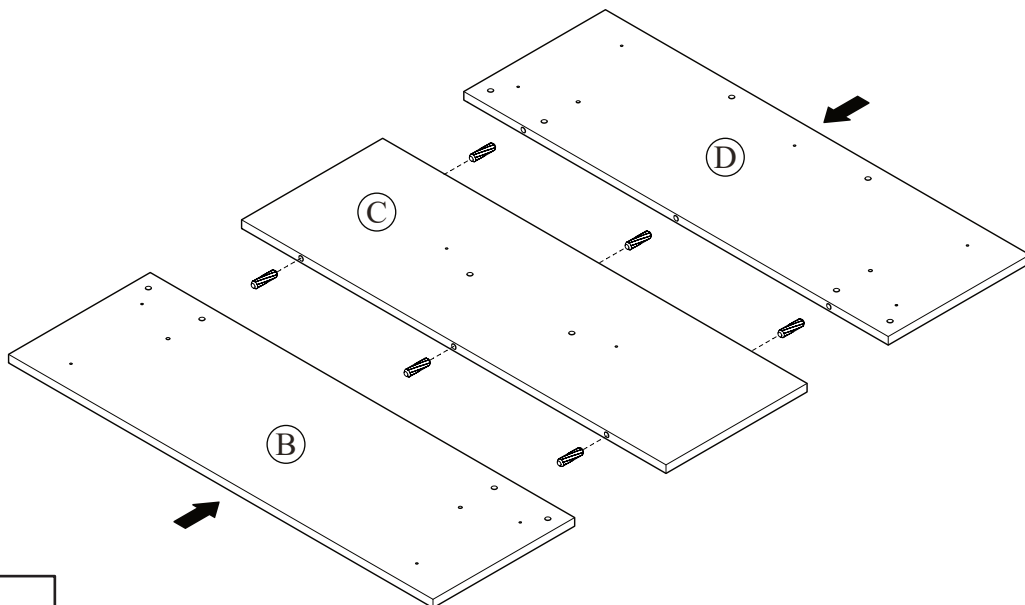
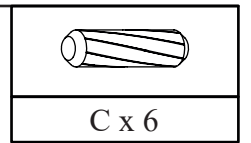

STEP 15

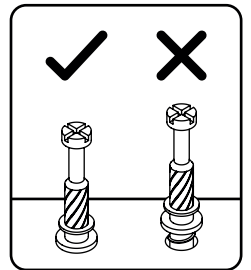
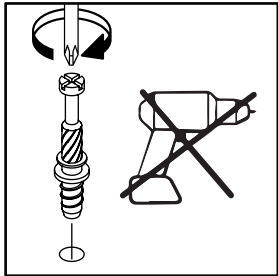
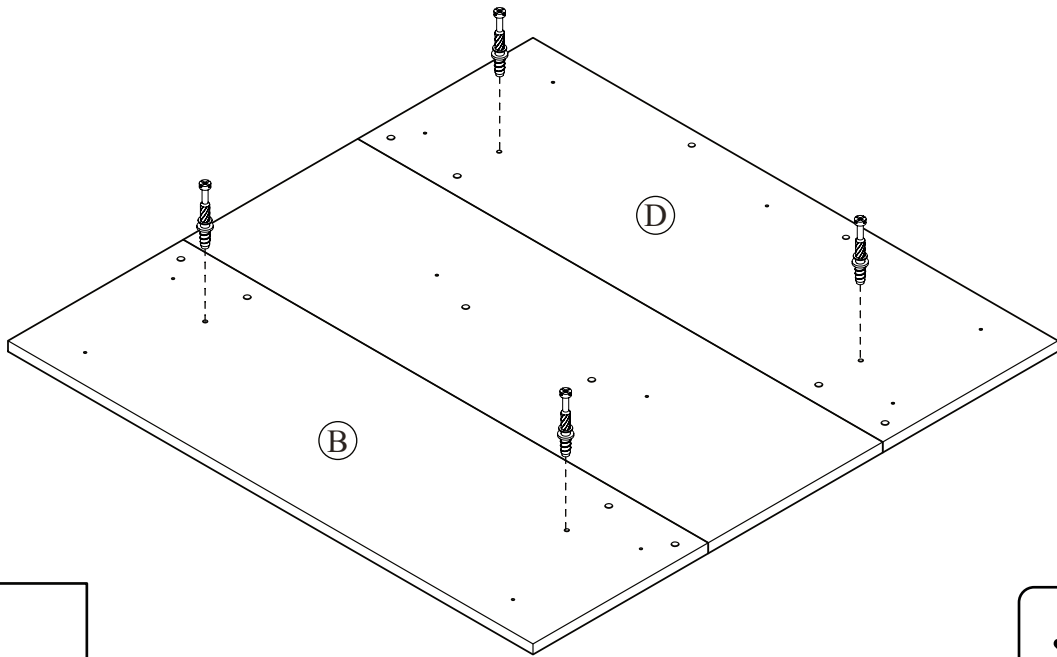
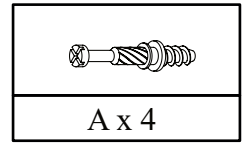

STEP 16

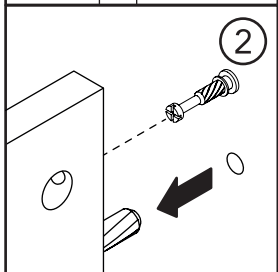
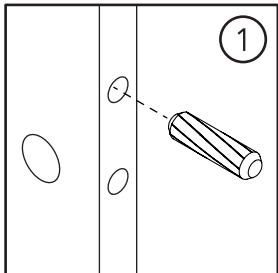
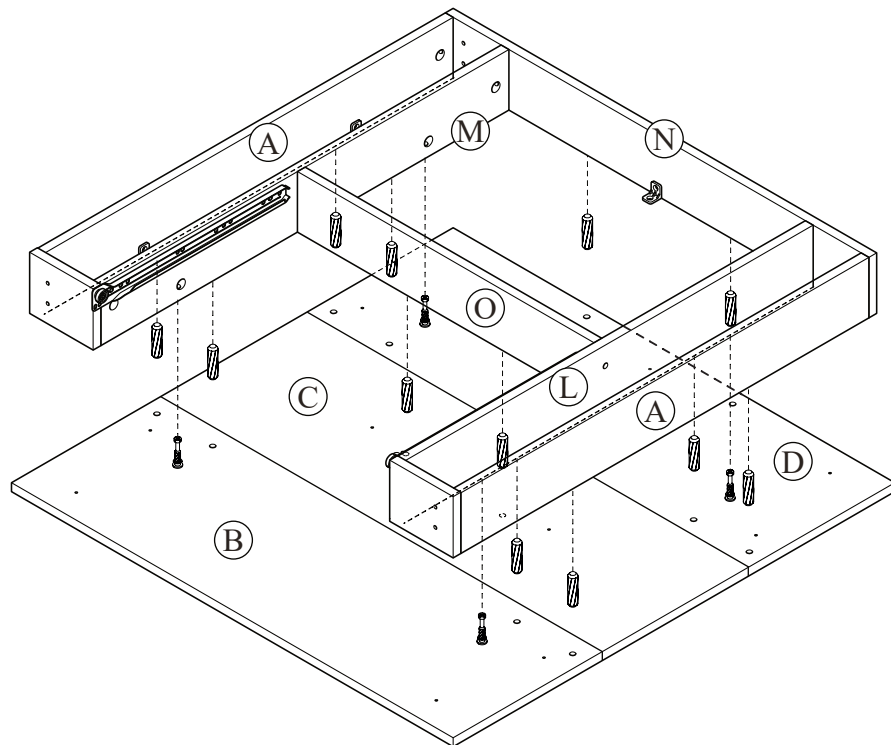
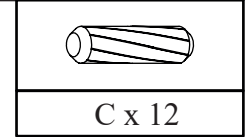

STEP 17

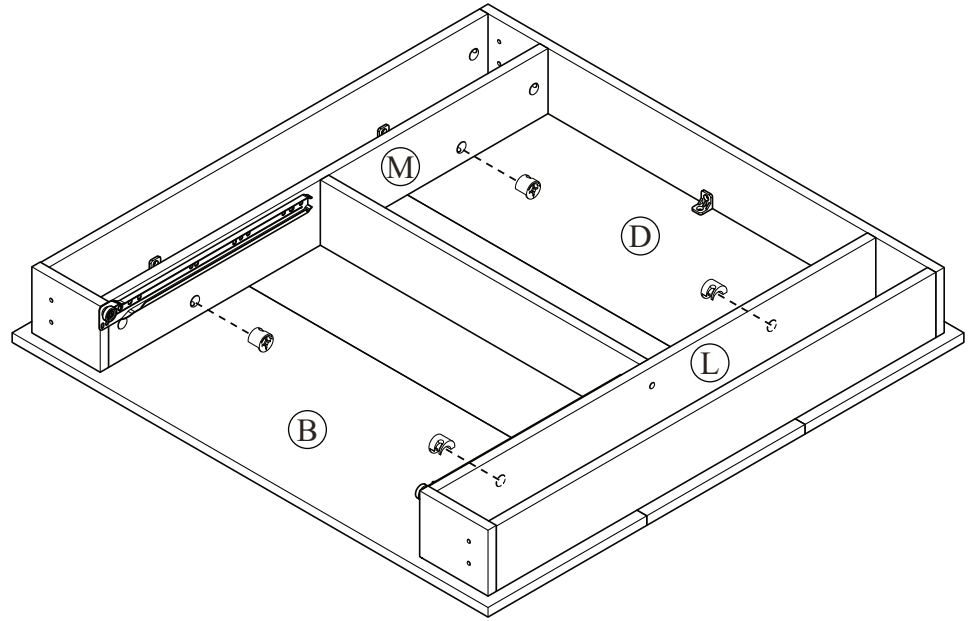
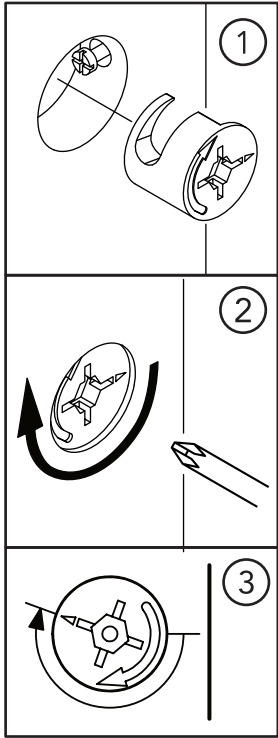
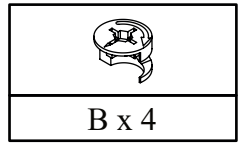

STEP 18

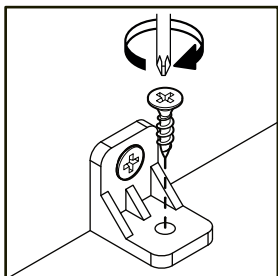
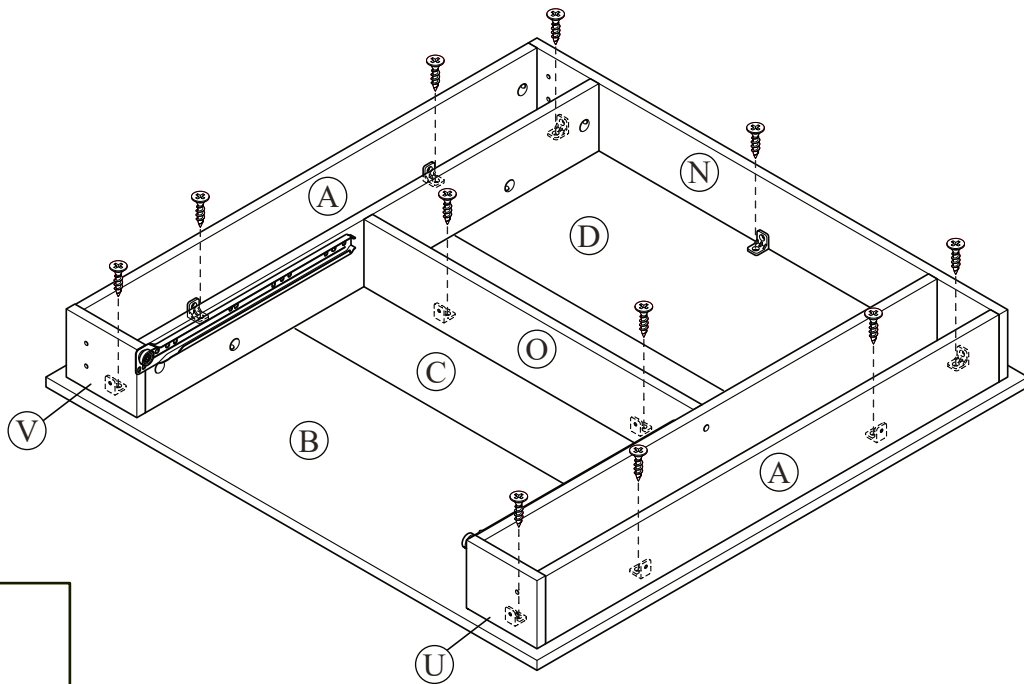
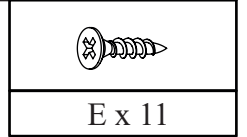

STEP 19

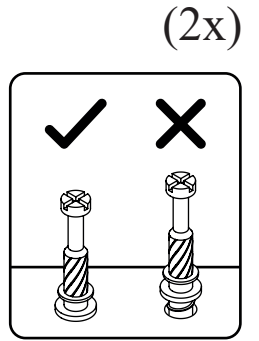
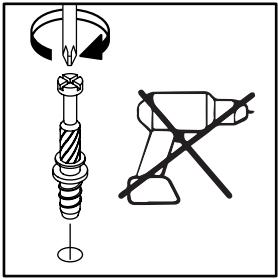
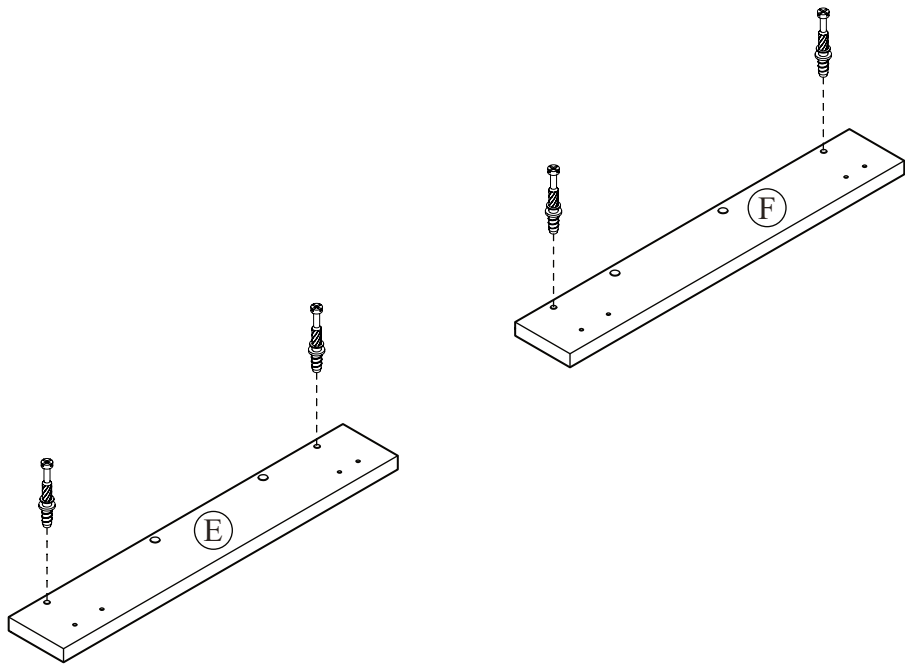
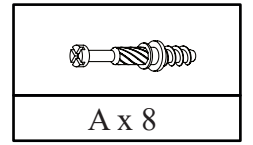

STEP 20

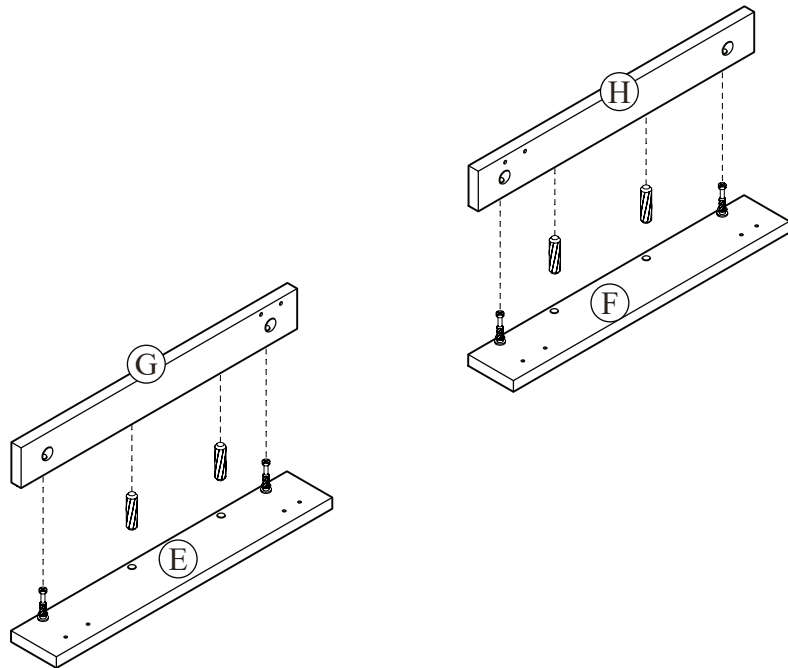
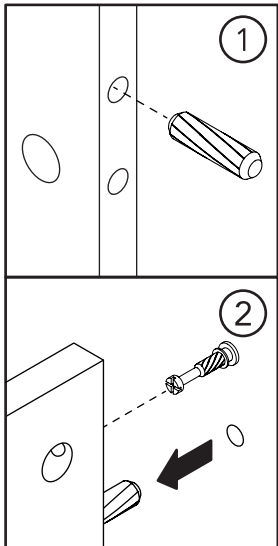
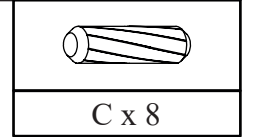

(2x)

STEP 21

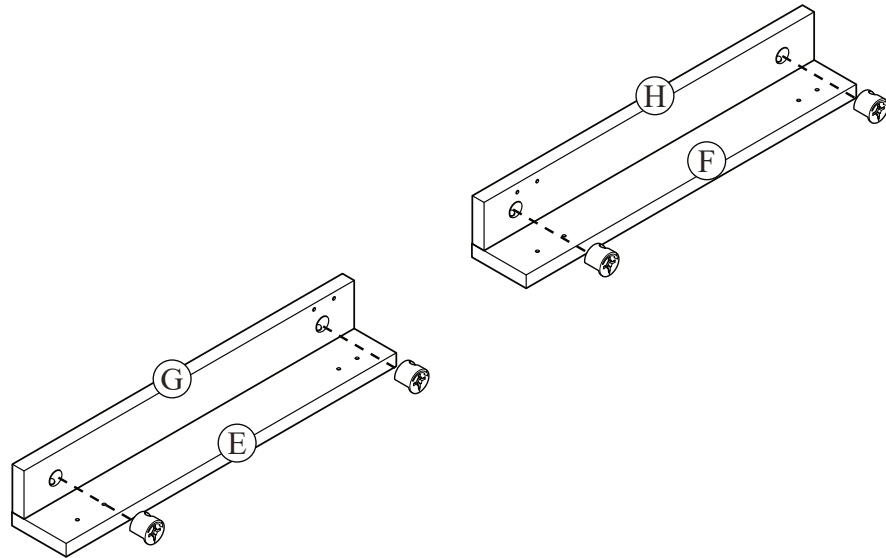
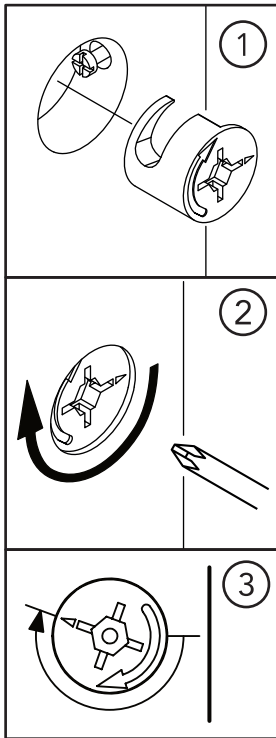
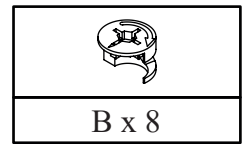

(2x)

STEP 22

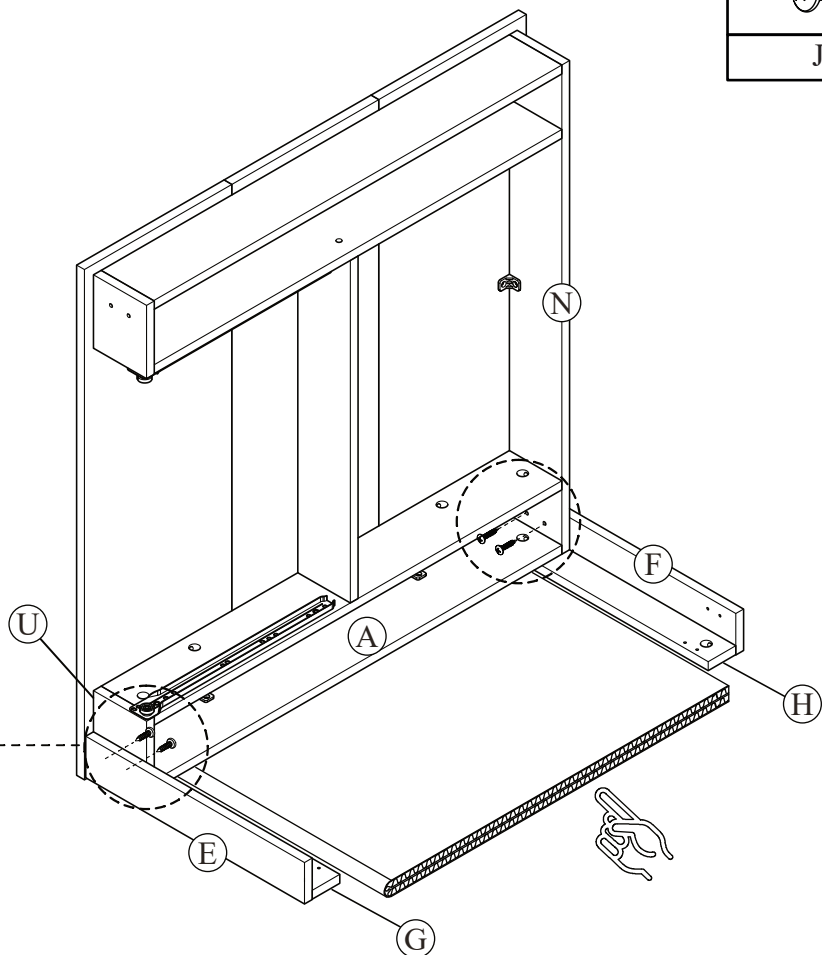
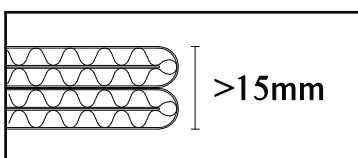
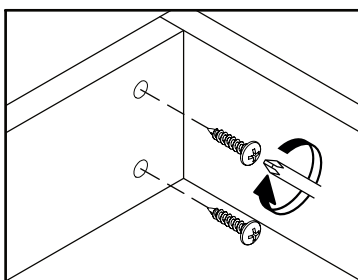
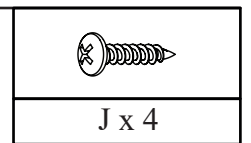

STEP 23

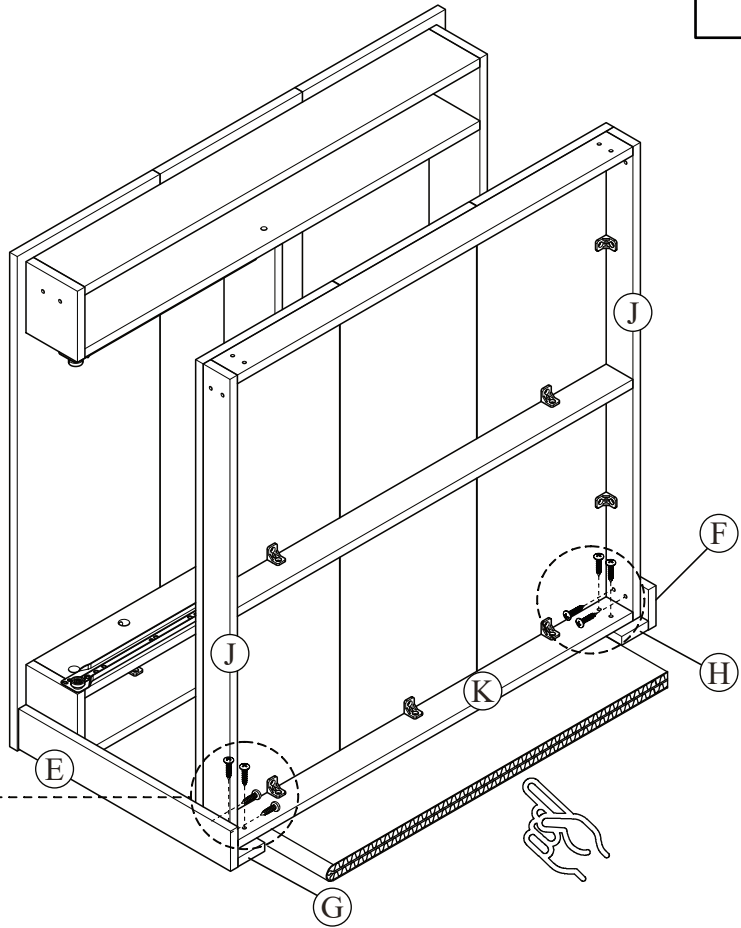
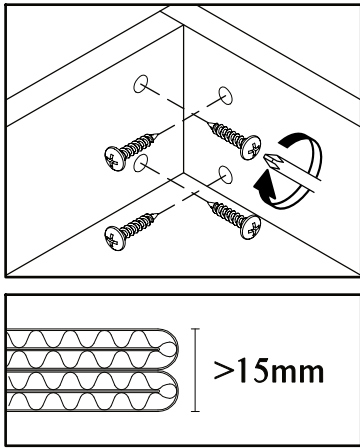
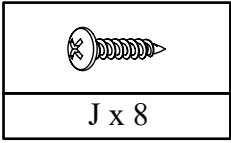

STEP 24

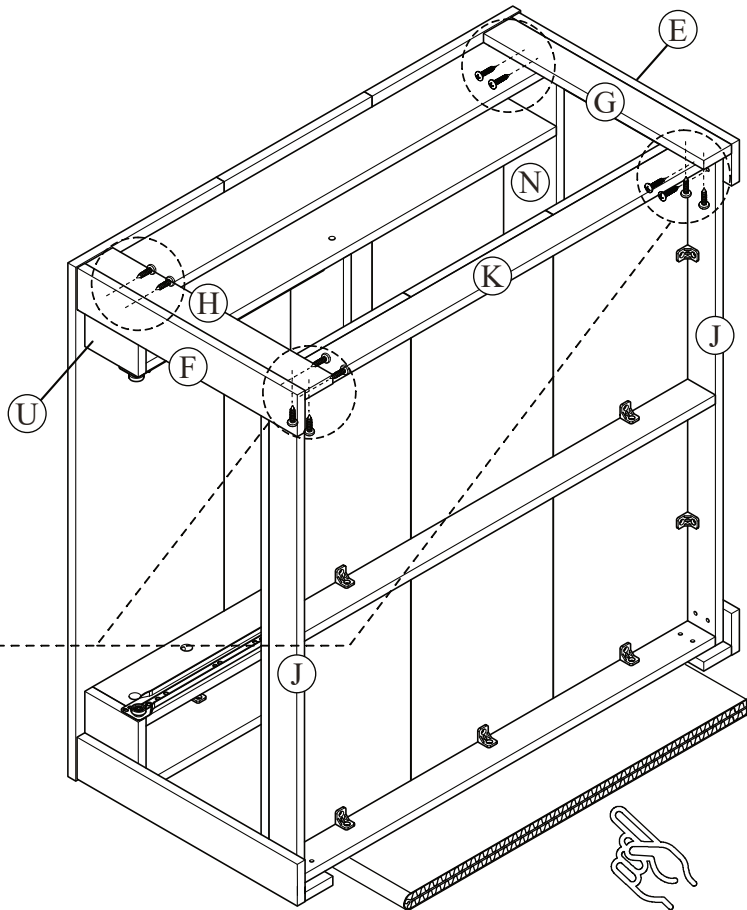
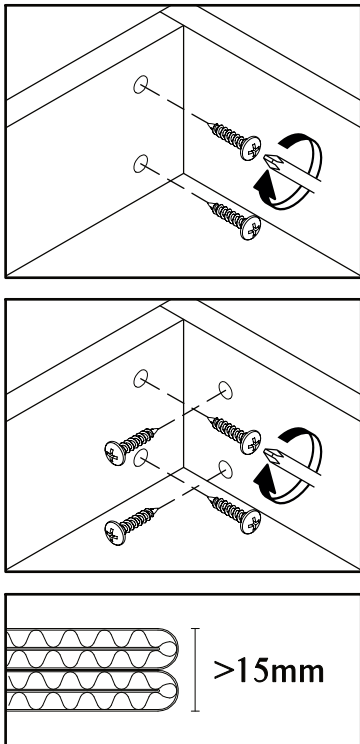
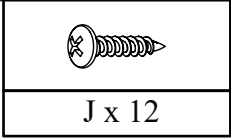

STEP 25

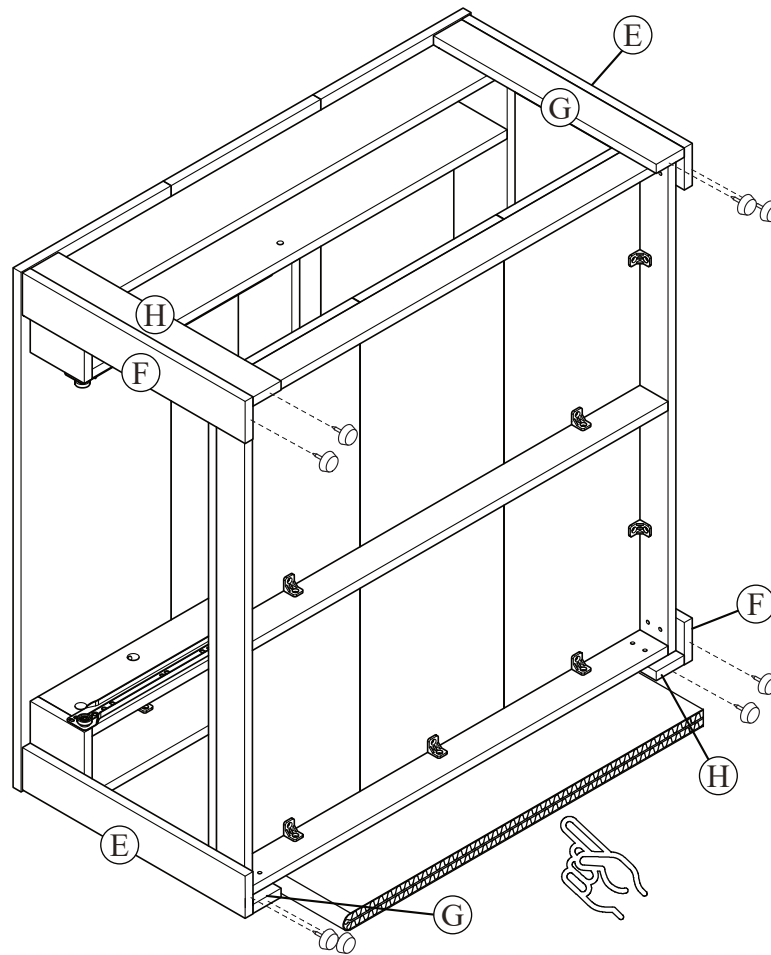
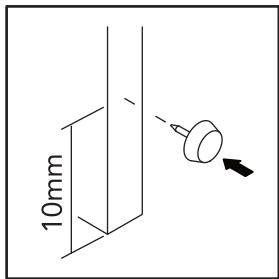
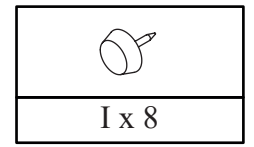

STEP 26

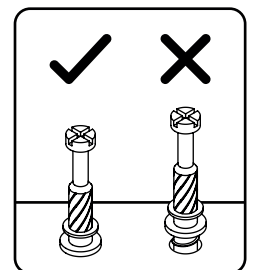
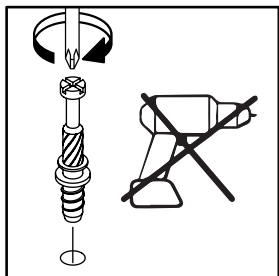
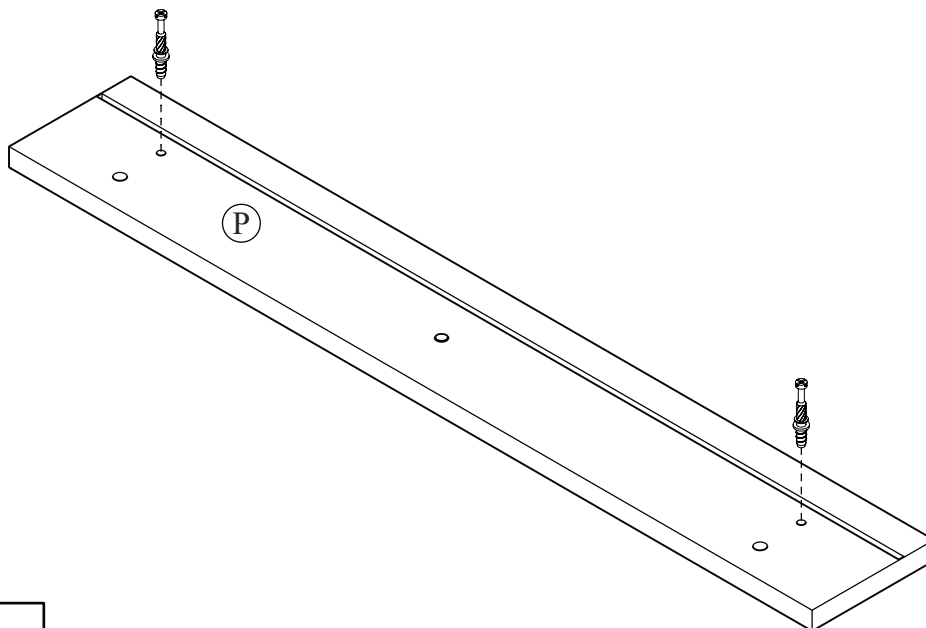
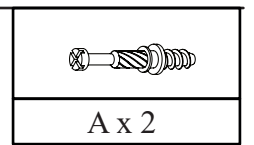

STEP 27

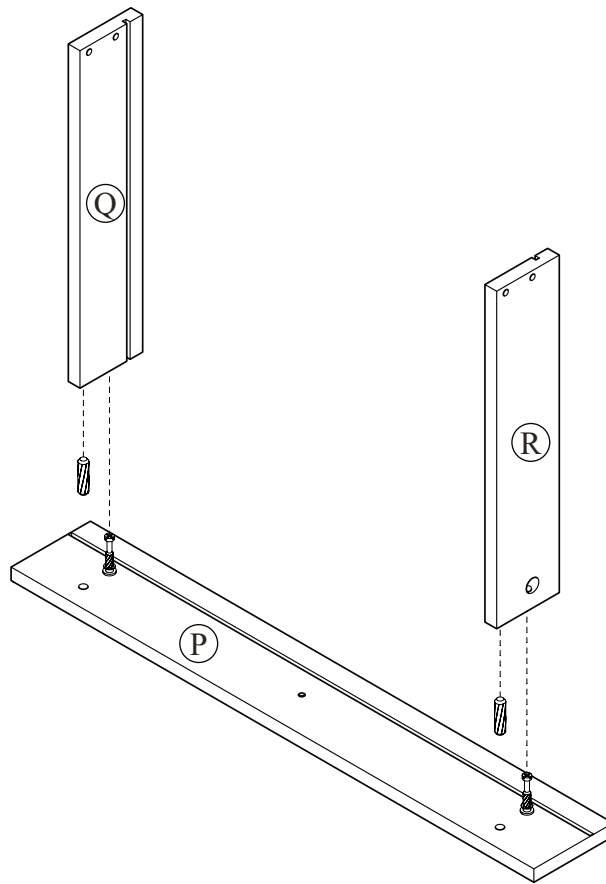
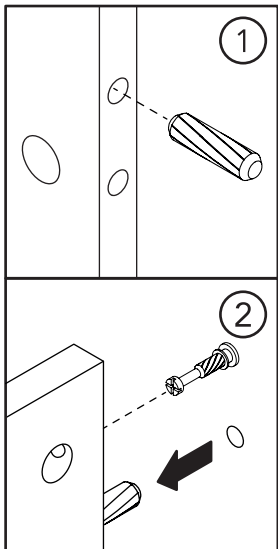
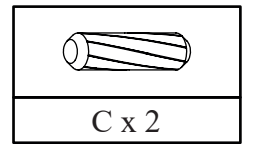

STEP 28

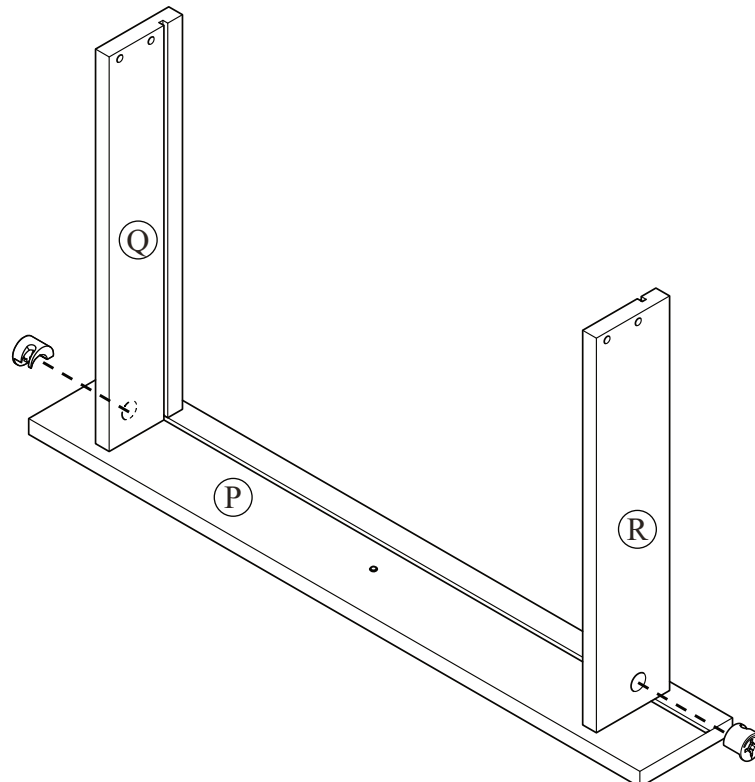
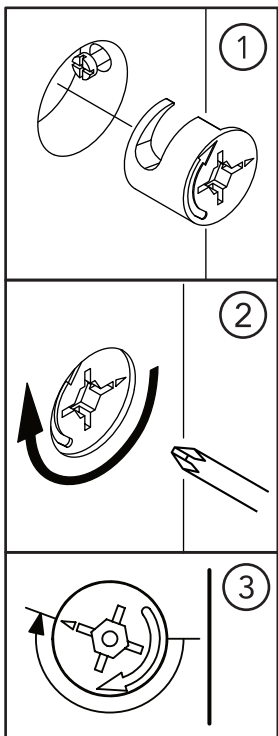
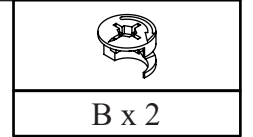

STEP 29

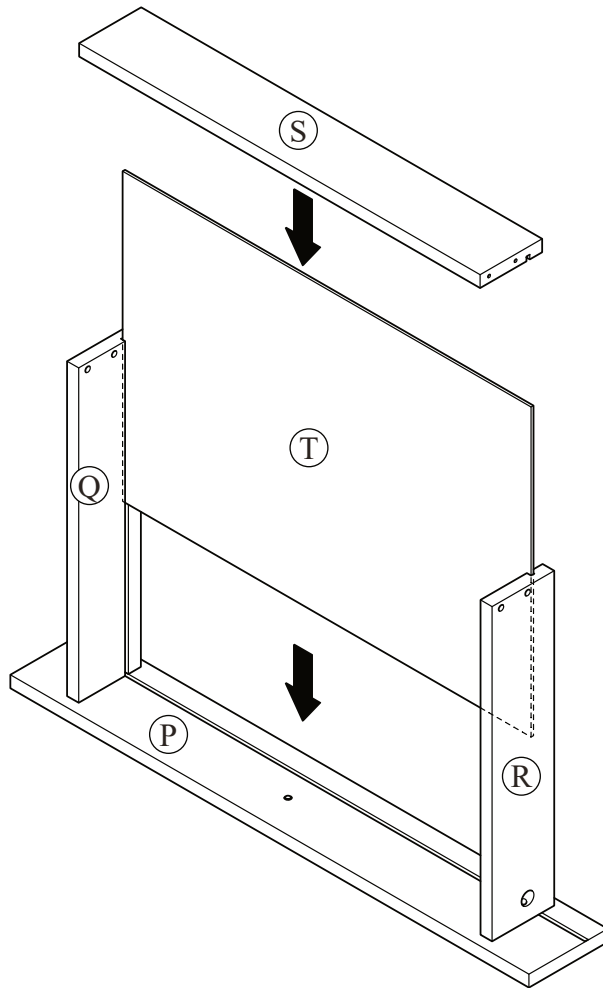

STEP 30

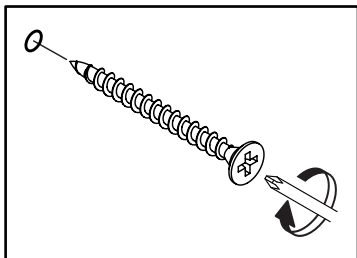
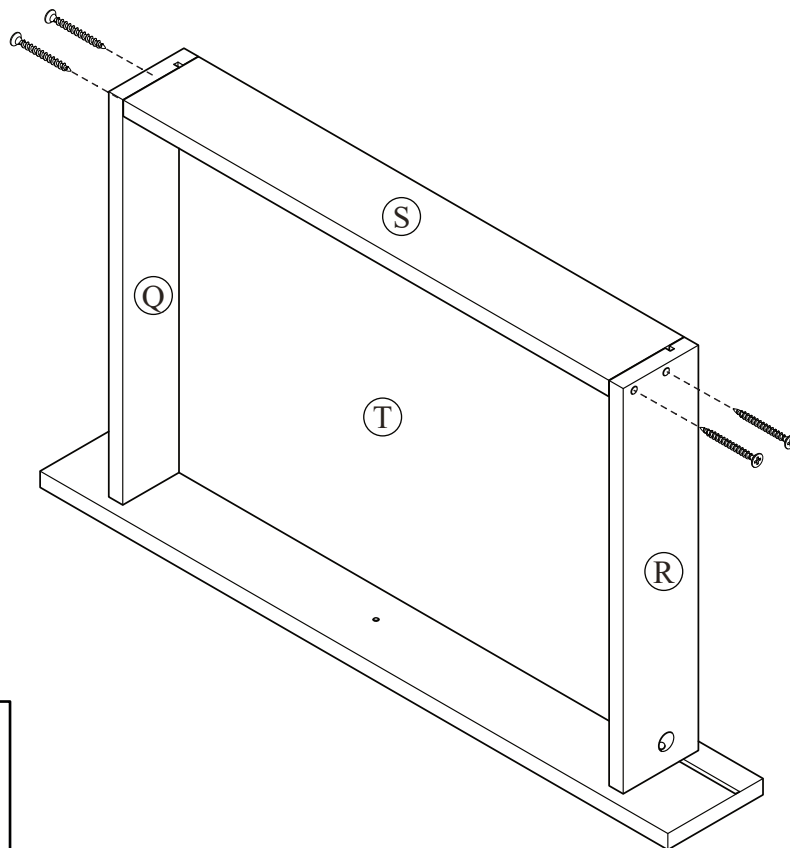
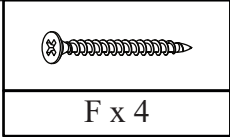

STEP 31

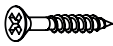
	
M x 1	P x 1

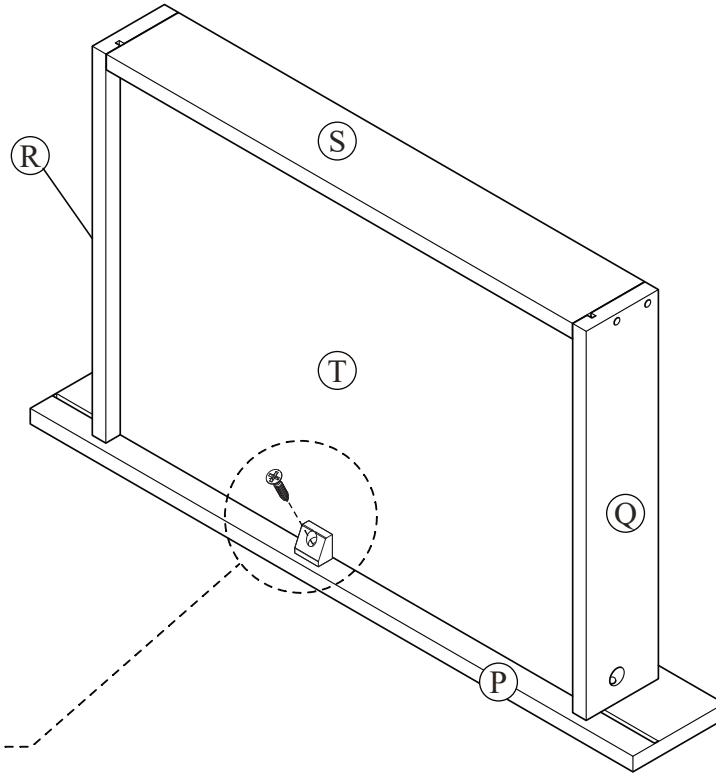
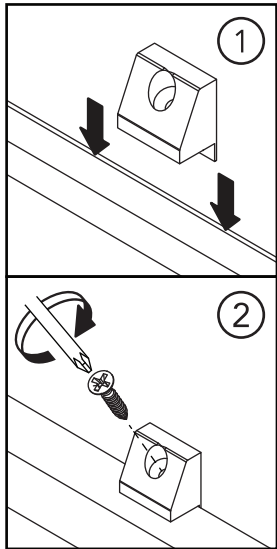

STEP 32

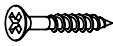
	
M x 1	P x 1

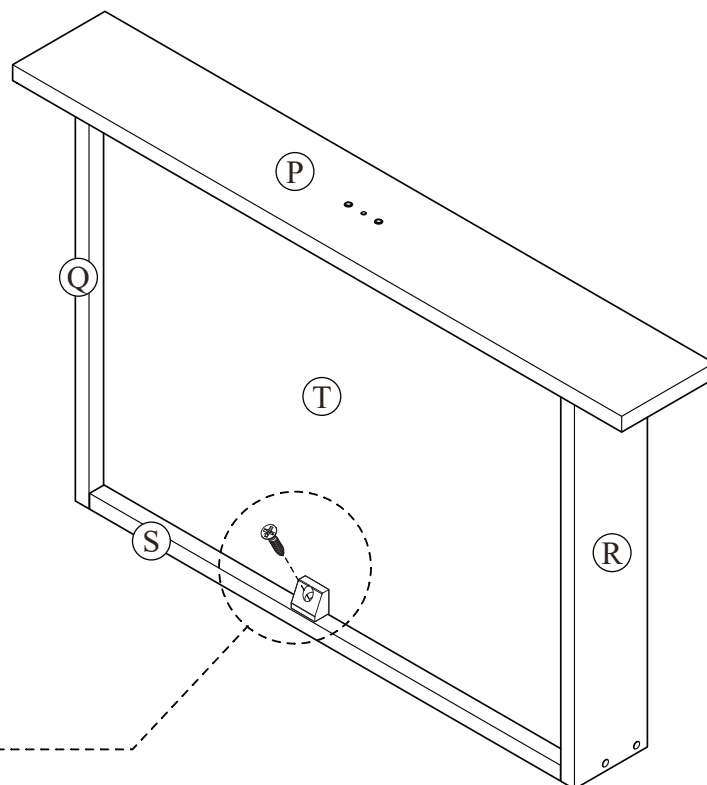
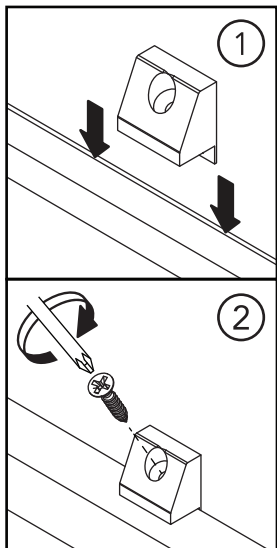

STEP 33

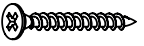
	
N x 1	O x 1

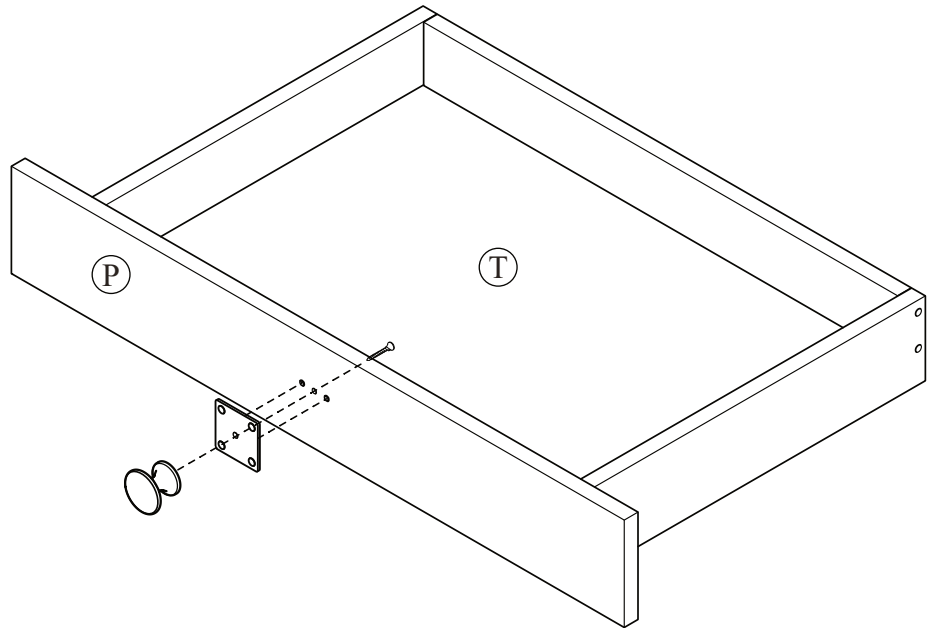
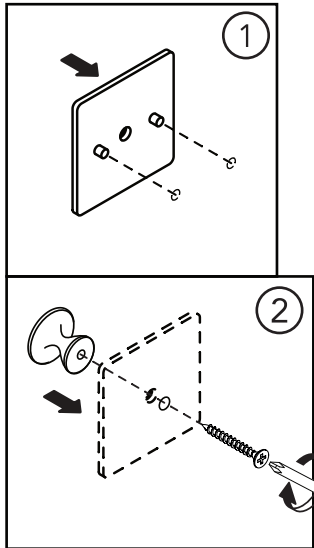

STEP 34

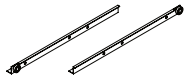
	
E x 4	L x 1

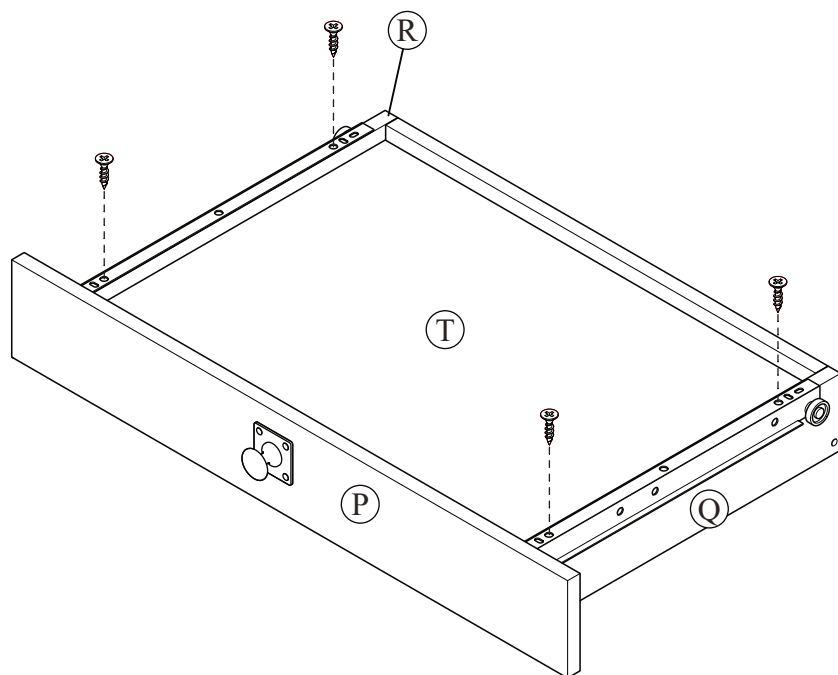
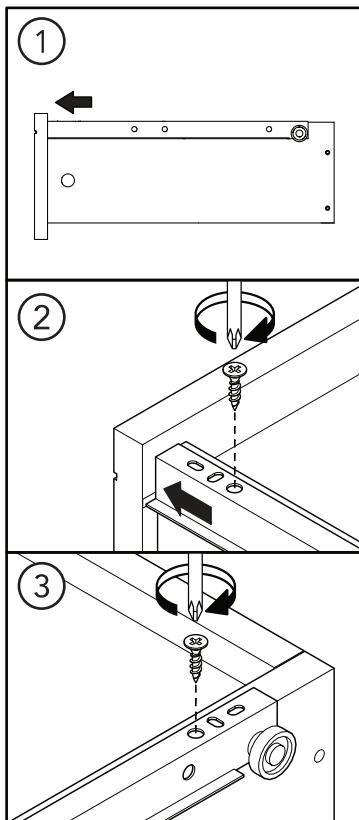

STEP 35

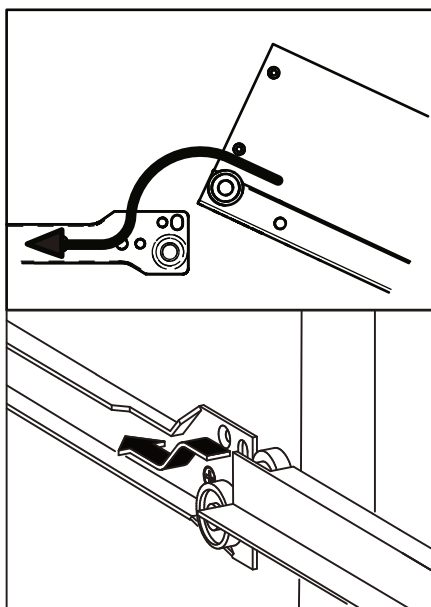
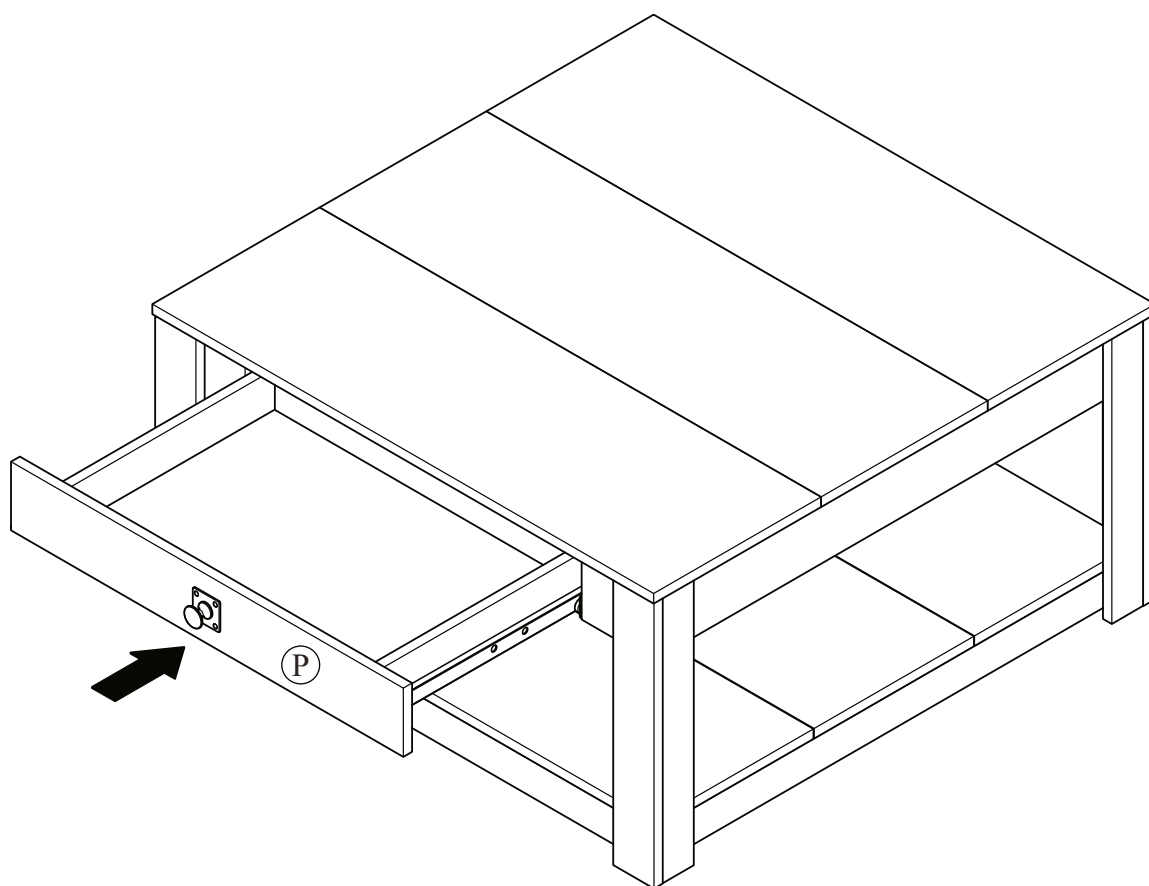

MAXIMUM LOADS CHARGES MAXIMALES / CARGA MAXIMA

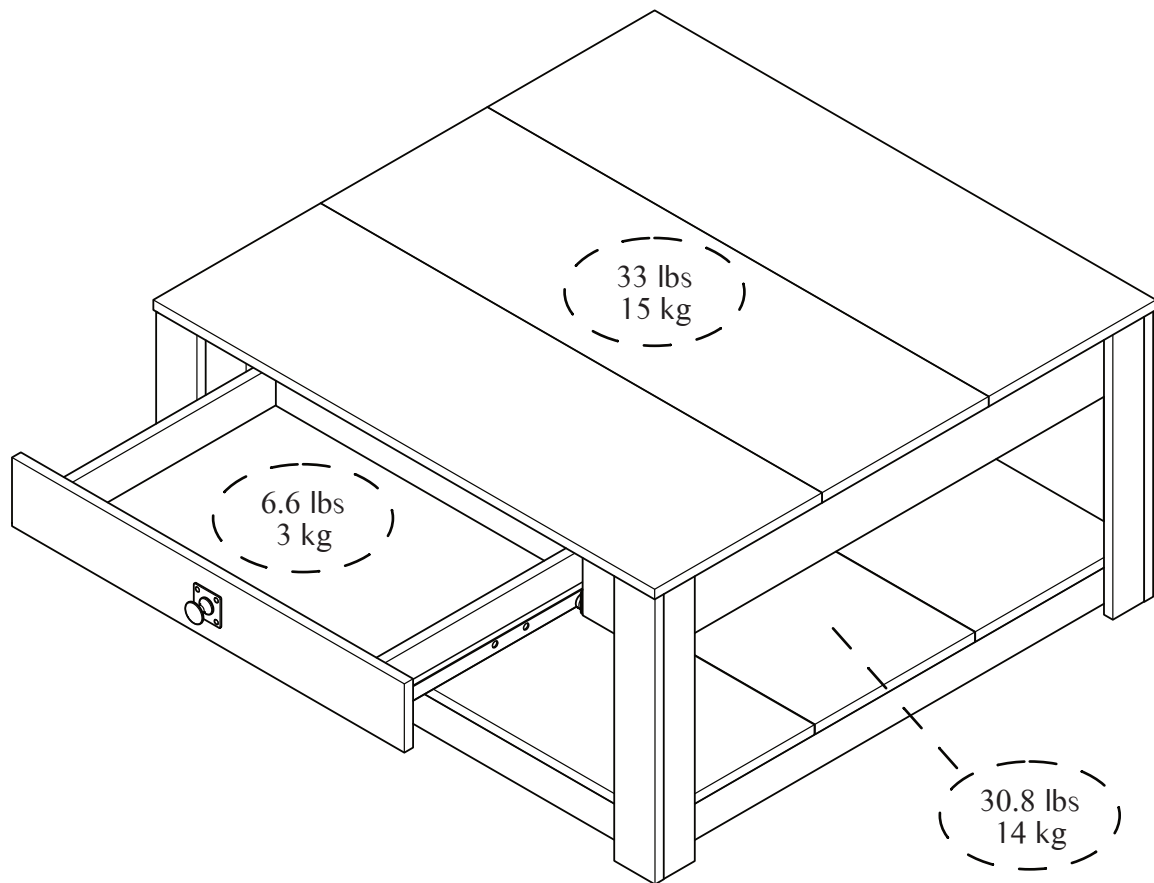

This unit has been designed to support the maximum loads shown. Exceeding these load limits could cause sagging, instability, product collapse, and/or serious injury.

Ce meuble a été conçu pour supporter les charges maximales indiquées. En excédant ces limites de charge, le meuble pourrait devenir instable, s'effondrer, et/ou causer des blessures graves.

Esta unidad ha sido diseñada para soportar la carga máxima anotada. El exceder estos límites puede causar inestabilidad, colapsarse y/o causar serias lesiones.
