

ASSEMBLY INSTRUCTIONS

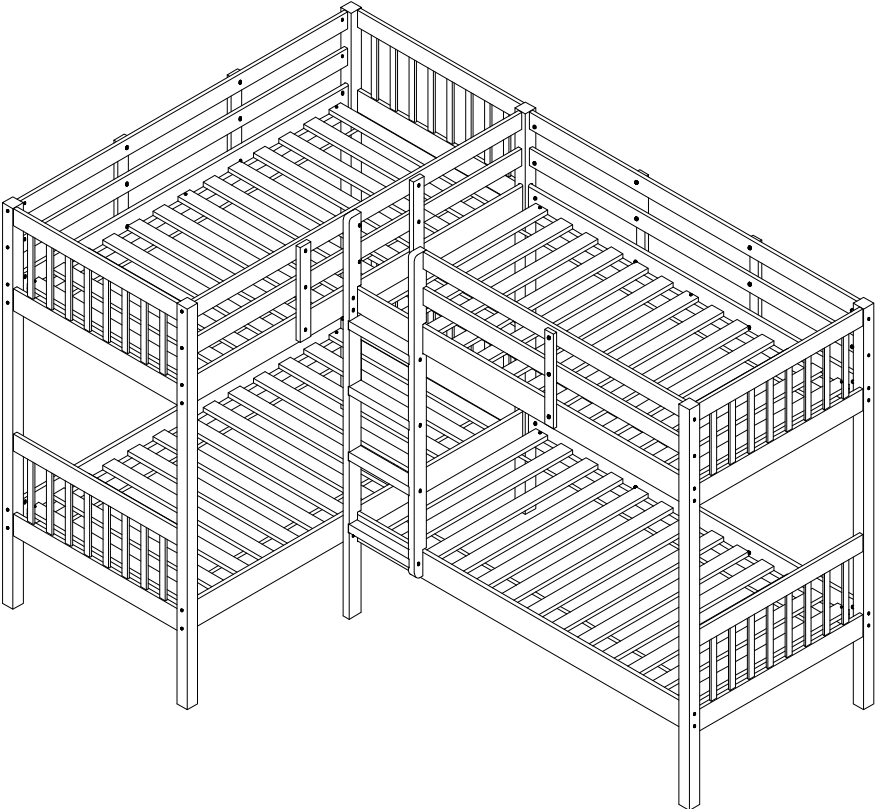

TOOLS REQUIRED



Allen Wrench
(Included)



Phillips
Screwdriver
(Not Included)



3 - People
Recommended

ASSEMBLY RATING



EASY ————— DIFFICULT

The Assembly Rating is a 5-point system showing the level of effort needed to assemble a specific product.

Thank you for your purchase!

We hope you enjoy this new addition to your home for many years to come.

Our commitment to providing quality products does not simply end when you purchase our product. We fully stand behind our products from start to finish. Our customer service department is available and can help with assembly questions as well as, if necessary, replacing damaged or missing parts. To help expedite our service, please have these assembly instructions readily available, along with your order receipt.



CHECK BEFORE STARTING

Are you missing anything?

Double-check all parts, hardware and accessories listed on Page 6 are accounted for.

Should we send any replacements?

Are there any irregularities or flaws in the parts? We can send replacements!

Check out our Quick Tips!

We recommend reviewing the pre-assembly handouts. Even experts need a refresher now and then!

Prep Time!

Please review the assembly instructions and all diagrams prior to assembling. Arrange parts as recommended on Page 7 and group identical hardware together to make assembling easier.

PRE ASSEMBLY INTRODUCTION

We understand building ready-to-assemble furniture can be a challenging experience for some. To help avoid confusion, we have provided some helpful tips that may speed up the process.



Teamwork

ALWAYS have at least two people to help with transporting and assembling the product to avoid potential injury and/or damage.



Suitable Location

Assembling near the area of the intended location is highly recommended.



Sufficient Space

Make sure you have enough space to move around during the assembly.



Avoid Scratches

Use cardboard, blankets or a carpeted area while assembling furniture to prevent to prevent scratches and damages.



Flat Surface

Make sure the furniture rests on a flat and level surface with each leg evenly touching the floor.

ASSEMBLY AND CARE ADVICE



FAILURE TO FOLLOW THE GUIDELINES BELOW MAY RESULT IN INJURY AND/OR PROPERTY DAMAGE.



Position each part correctly and insert screws or bolts into their respective holes.



Turn clockwise to tighten and only tighten when step is completed or when instructed to do so.



Use the appropriate hand tools or power tools for assembly. Select steps, such as tightening screws and/or bolts, may require hand tools to avoid causing damage during assembly.



Save the instructions and store any supplied tools for later maintenance.



After two weeks, check and tighten any loose hardware and repeat again every six months thereafter.

IT IS THE USER'S RESPONSIBILITY TO MAINTAIN THE FURNITURE. THE HARDWARE MAY LOOSEN OVER TIME AND MAY CAUSE THE FURNITURE TO BE WOBBLY AND UNABLE TO SUPPORT ITS INTENDED WEIGHT CAPACITY. THIS MAY LEAD TO COLLAPSE AND MAY CAUSE SERIOUS INJURY.

DAYBED



• Please keep instructions for future reference.
 • Check the quantity and irregularity of parts and hardware before you start.

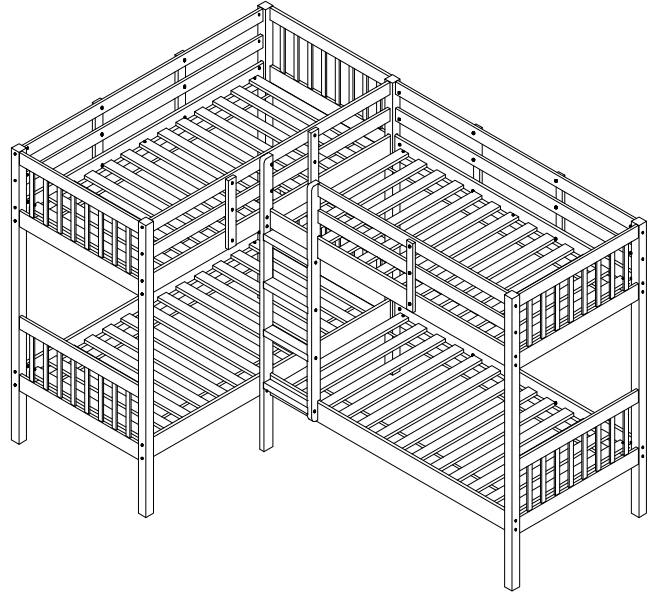

PARTS

#1 1pc

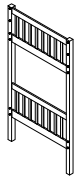

Headboard

#5 1pc

#2 1pc

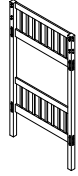

Headboard

#5.1 1pc

#3 1pc

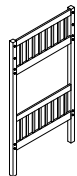

Headboard

#6 1pc

#4 1pc

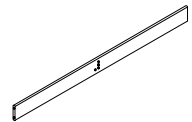

Lower Front Side Rail

#7 1pc

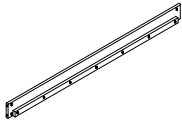

Lower Back Side Rail

#7.1 1pc

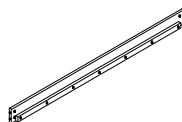

Lower Back Side Rail

#8 1pc

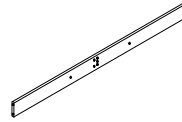

Upper Front Side Rail

#9 1pc

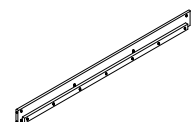

Upper Back Side Rail

#10 2pcs

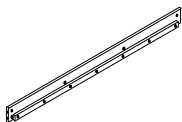

Upper Back Side Rail

#11 4pcs

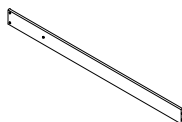

Lower Front Side Rail

#12 2pcs

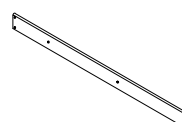

Upper Front Side Rail

#13 7pcs

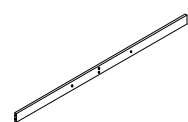

Front Guardrail

#14 1pc

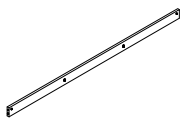

Back Guardrail

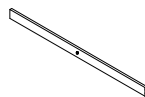

Front Guardrail



Guardrail

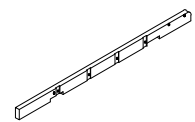

Ladder Rail (L)

PARTS

#15 1pc

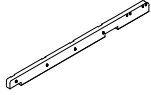

Ladder Rail (R)

#16 1pc



Ladder Rung

#17 3pcs

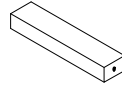

Ladder Rung

#18 4set

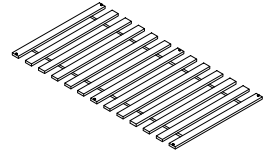

Twin Slats Kit
(13pcs)

HARDWARE

#A 42pcs



Bolt
Ø1/4" x 4"

#B 48pcs



Barrel Nut
Ø1/4" x 4"

#C 6pcs



Bolt
Ø1/4" x 3-1/8"

#D 11pcs



Bolt
Ø1/4" x 1-3/4"

#E 21pcs



Bolt
Ø1/4" x 1-3/16"

#F 8pcs

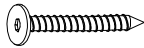

Screw
Ø1/4" x 2"

#G 20pcs



Wood Dowel
Ø10x40mm

#H 24pcs



Screw
#4 x 30mm

#I 1pc



Allen Wrench
4mm

#J 26pcs







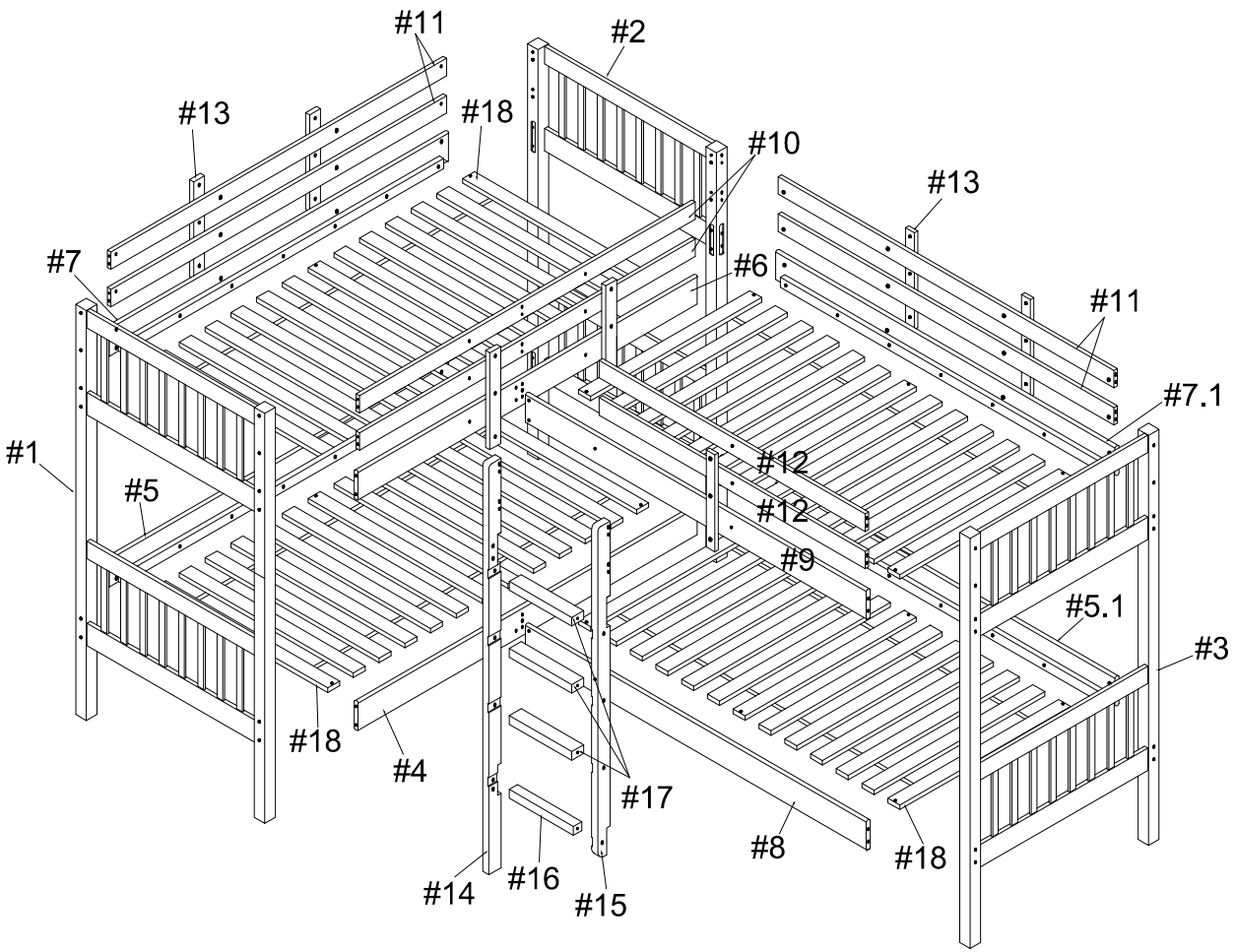

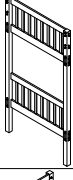
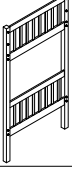
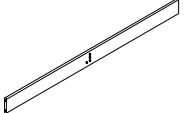
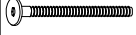

Hex Cap
Ø1/4" x 5/8"

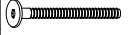
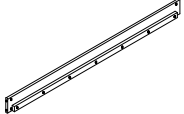
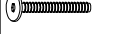

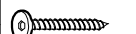
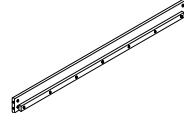

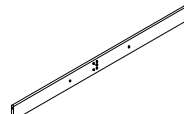
Exploded View

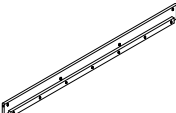
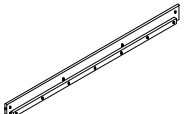
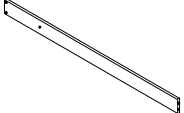

CM-BK904 is packed in 3 cases

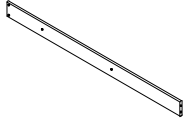
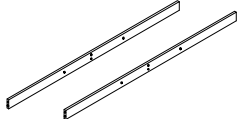
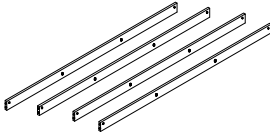
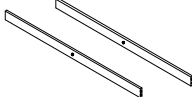
Carton	Disignation	Part		Hardware
CM-BK904-1	Heardboard	#1		
	Heardboard	#2		
	Heardboard	#3		
CM-BK904-2	Lower Front Side Rail	#4		 #Ax42pcs  #Bx48pcs  #Cx6pcs
	Lower Back Side Rail	#5		 #Dx11pcs  #Ex21pcs  #Fx8pcs
	Lower Back Side Rail	#5.1		 #Gx20pcs  #Hx24pcs
	Upper Front Side Rail	#6		 #Ix1pc  #Jx26pcs
	Upper Back Side Rail	#7		
	Upper Back Side Rail	#7.1		
	Lower Front Side Rail	#8		

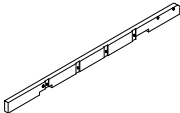
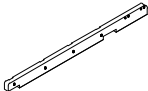
CM-BK904 is packed in 3 cases

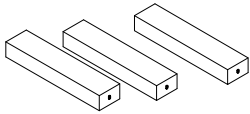
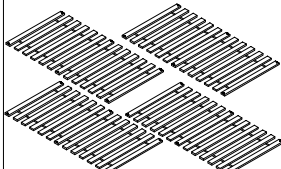
Carton	Disignation	Part		Hardware
CM-BK904-2	Upper Front Side Rail	#9		
	Front Guardrail	#10		
	Back Guardrail	#11		
	Front Guardrail	#12		
	Guardrail	#13		
	Ladder Rail (L)	#14		
	Ladder Rail (R)	#15		
	Ladder Rung	#16		
	Ladder Rung	#17		
CM-BK904-3	Twin Slats Kit	#18		

ASSEMBLY INSTRUCTIONS

1

- Part #1 x 1pc
- Part #2 x 1pc
- Part #4 x 1pc
- Part #5 x 1pc
- Part #6 x 1pc
- Part #7 x 1pc
- Part #10 x 2pcs
- Part #11 x 2pcs
- Hardware #A x 24pcs
- Hardware #B x 24pcs
- Hardware #C x 8pcs

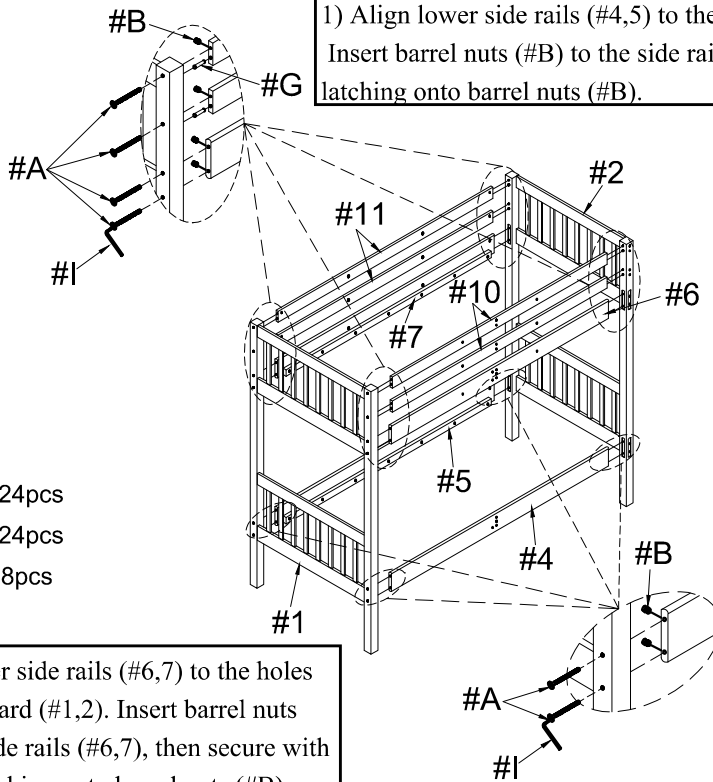

1) Align lower side rails (#4,5) to the bottom holes of the headboard (#1,2). Insert barrel nuts (#B) to the side rails (#4,5), then secure with bolts (#A) latching onto barrel nuts (#B).

2) Align upper side rails (#6,7) to the holes of the headboard (#1,2). Insert barrel nuts (#B) to the side rails (#6,7), then secure with bolts (#A) latching onto barrel nuts (#B).
 3) Align upper guardrails (#10,11) to the holes of the headboard (#1,2). Insert barrel nuts (#B) and wood dowels (#G) to the guardrails (#10,11), then secure with bolts (#A) latching onto barrel nuts (#B).

2

Align guardrail bracket (#13) to the holes of the upper side rails, then secure with bolts (#E).

- Part #13 x 4pcs
- Hardware #E x 12pcs
- Hardware #J x 12pcs

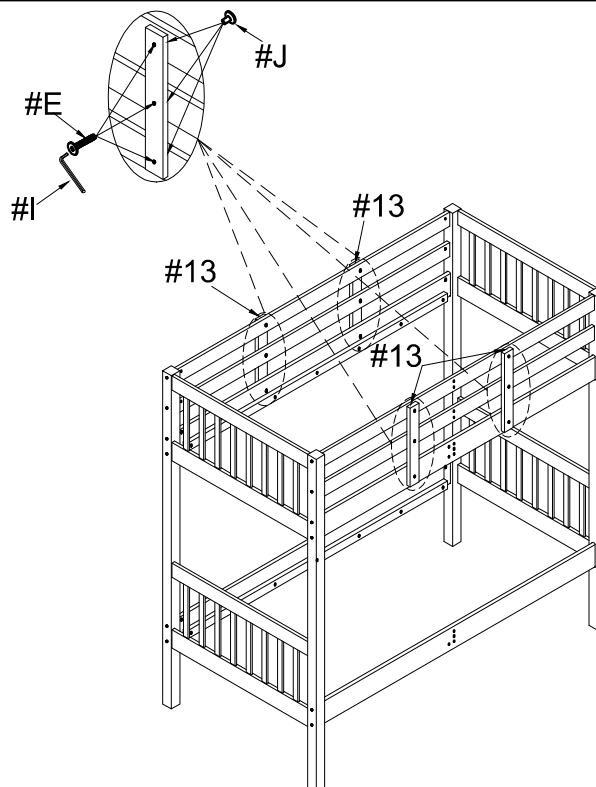

ASSEMBLY INSTRUCTIONS

3

- Part #14 x 1pc
- Part #15 x 1pc
- Part #16 x 1pc
- Part #17 x 3pcs
- Hardware #F x 8pcs

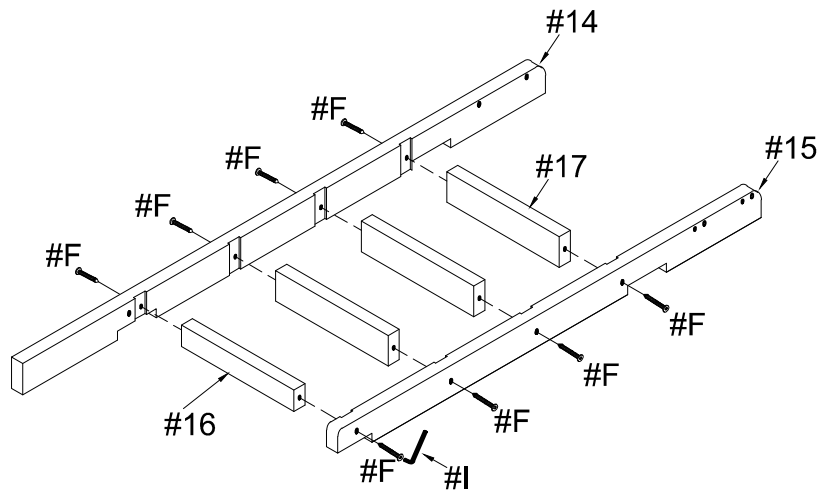

Align ladder rung (#16,17) to the holes of the ladder rails (#14,15), then secure with screws (#F).

4

- Part #3 x 1pc
- Part #5.1 x 1pc
- Part #7.1 x 1pc
- Part #8 x 1pc
- Part #9 x 1pc
- Hardware #A x 12pcs
- Hardware #B x 16pcs
- Hardware #C x 4pcs
- Hardware #G x 2pcs

1) Align side rails (#5.1,7.1,8,9) to the holes of the headboard (#3) and side rails (#4,6). Insert barrel nuts (#B) to the side rails (#5.1,7.1,8,9).

2) Secure with bolts (#A) latching onto barrel nuts (#B).

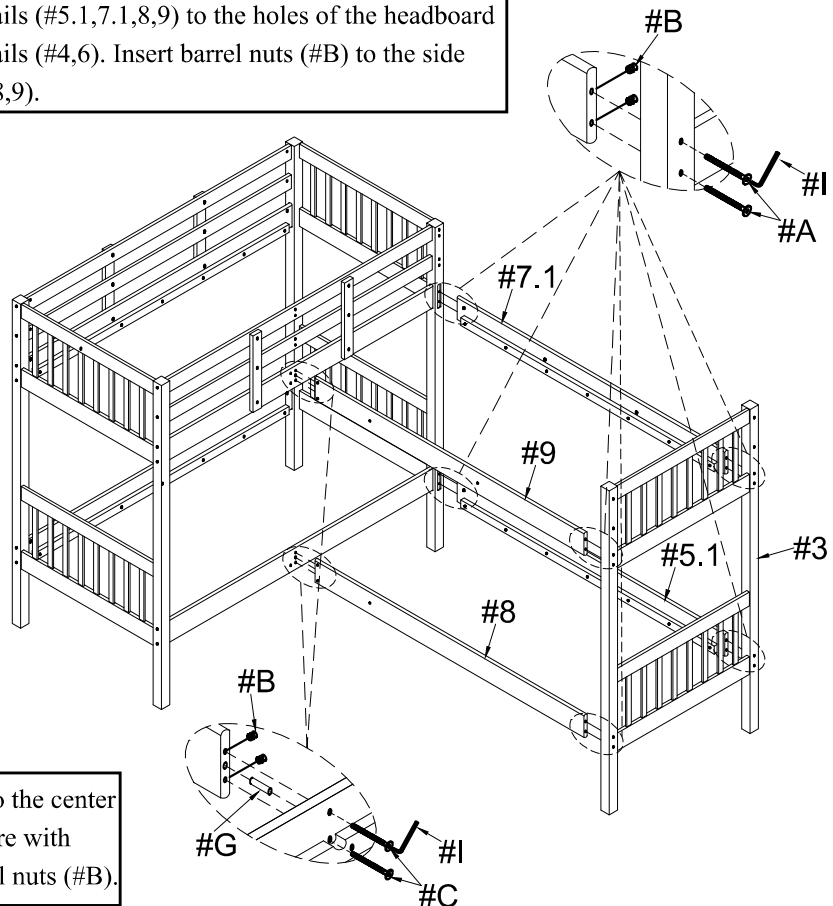

DO NOT
TIGHTEN YET.

3) Insert wood dowels (#G) to the center hole of side rails (#8,9). Secure with bolts (#C) latching onto barrel nuts (#B).

ASSEMBLY INSTRUCTIONS

Insert wood dowels (#G) and barrel nuts (#B) to the hole of the guardrails (#11,12). Align the guardrails (#11,12) to the holes of the headboard (#2,3), then secure with bolts (#A) latching onto barrel nuts (#B).

5

- Part #11 x 2pcs
- Part #12 x 2pcs
- Hardware #A x 6pcs
- Hardware #B x 6pcs
- Hardware #G x 6pcs

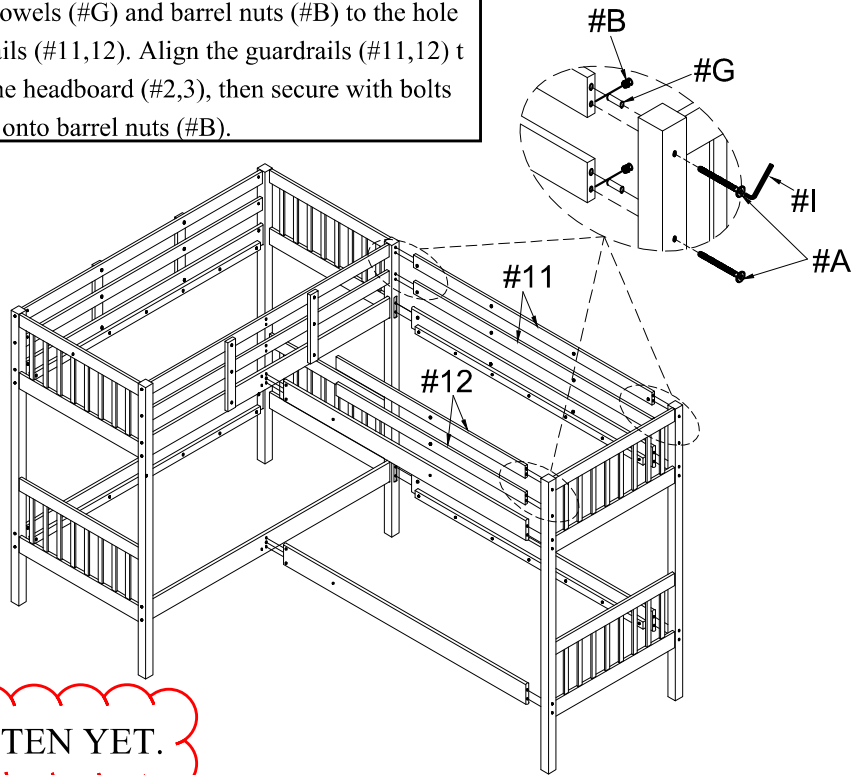

DO NOT TIGHTEN YET.

Align ladder to the holes of the front guardrail (#10,12). Secure ladder on guardrail (#10) with bolts (#D), then ladder on guardrail (#12) with bolts (#C).

6

- Hardware #B x 2pcs
- Hardware #C x 2pcs
- Hardware #D x 2pcs
- Hardware #G x 4pcs
- Hardware #J x 2pcs

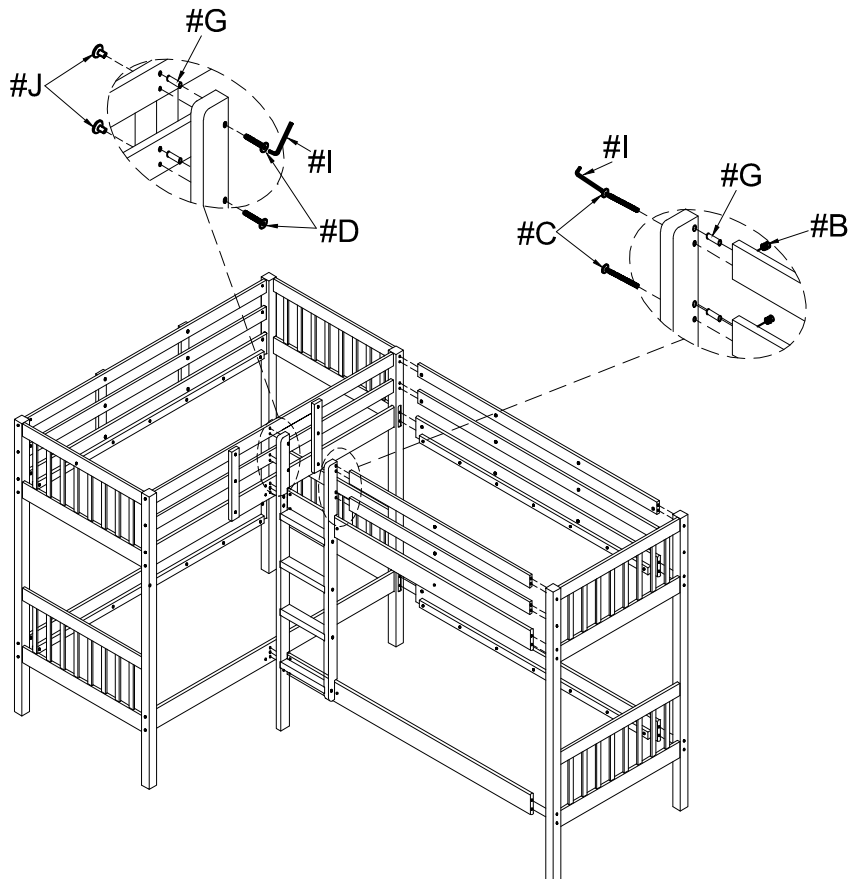

TIGHTEN ALL BOLTS
FROM STEPS 4 AND 5.

ASSEMBLY INSTRUCTIONS

Align the holes of the ladder to the holes of the side rails (#4,6). Secure with bolts (#D).

7

Hardware  #D x 3pcs
Hardware  #J x 3pcs

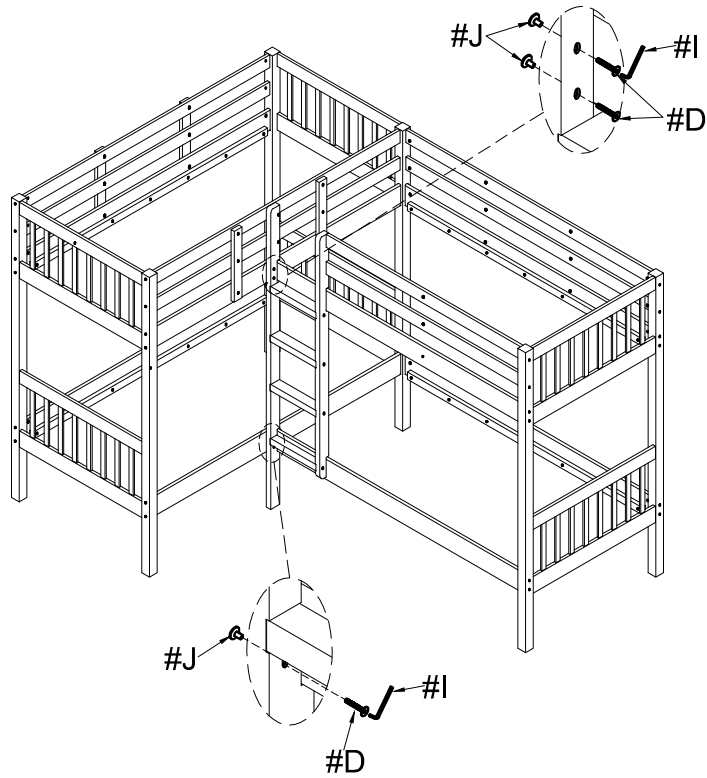

8

Align ladder holes to the side rails (#8,9), then secure with bolts (#D).

Hardware  #D x 6pcs

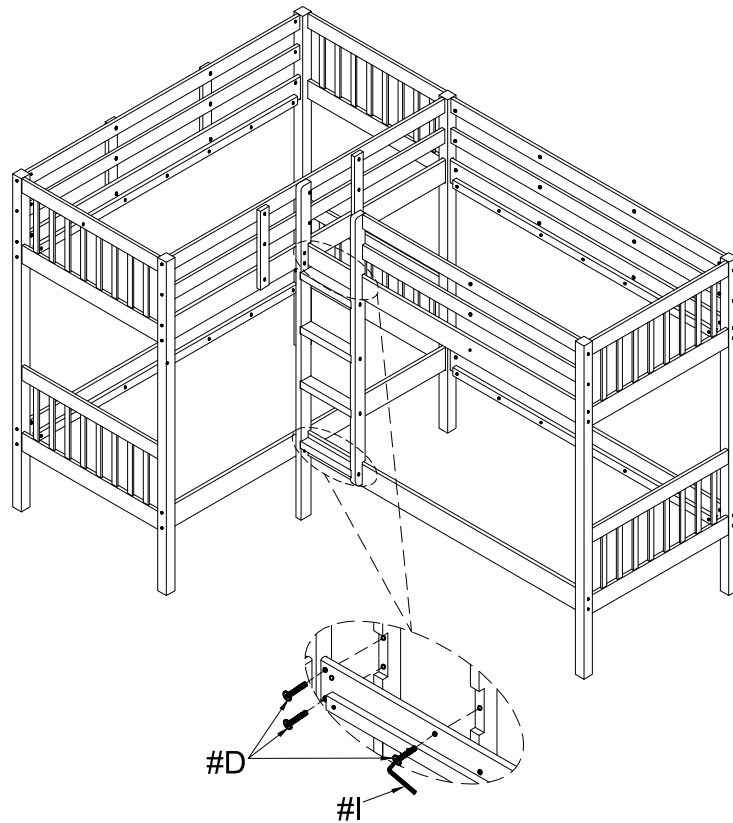

ASSEMBLY INSTRUCTIONS

Align guardrail brackets (#13) to the holes of the guard and side rails. Secure with bolts (#E).

9

Part #13 x 3pcs
Hardware #E x 9pcs
Hardware #J x 9pcs

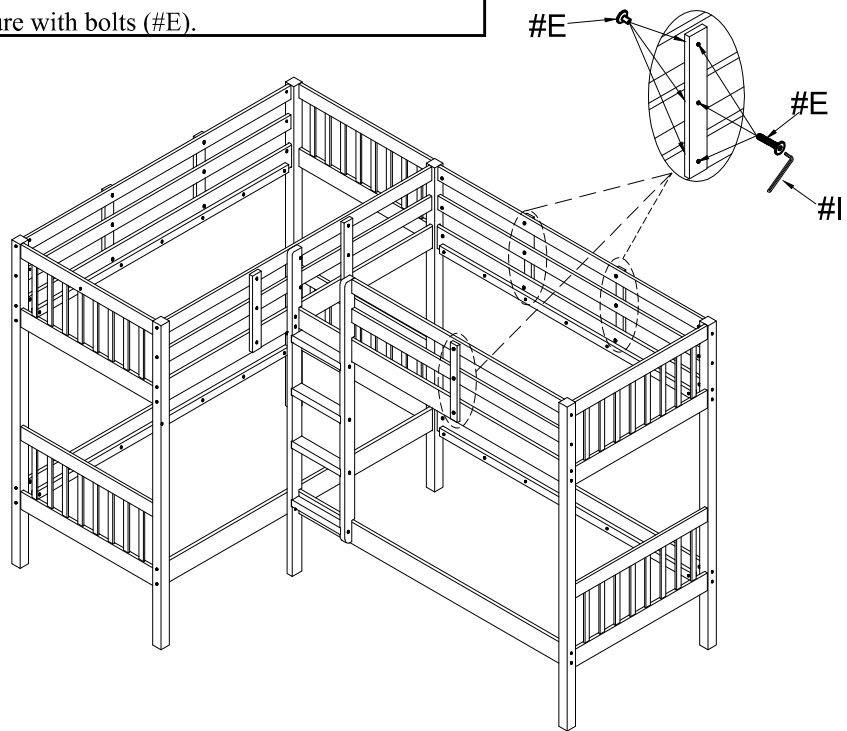

Align slats (#18) to the side rails, then secure with screws (#H).

10

Part #18 x 4set
Hardware #H x 24pcs

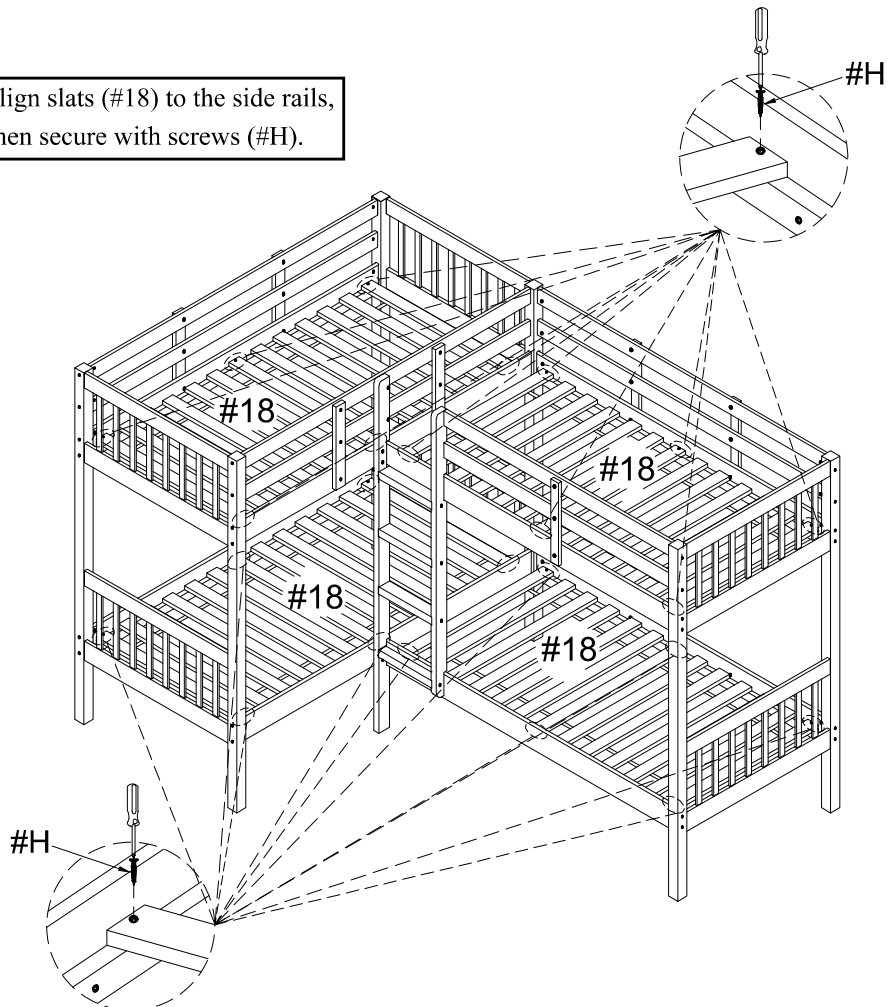

ASSEMBLY INSTRUCTIONS

11

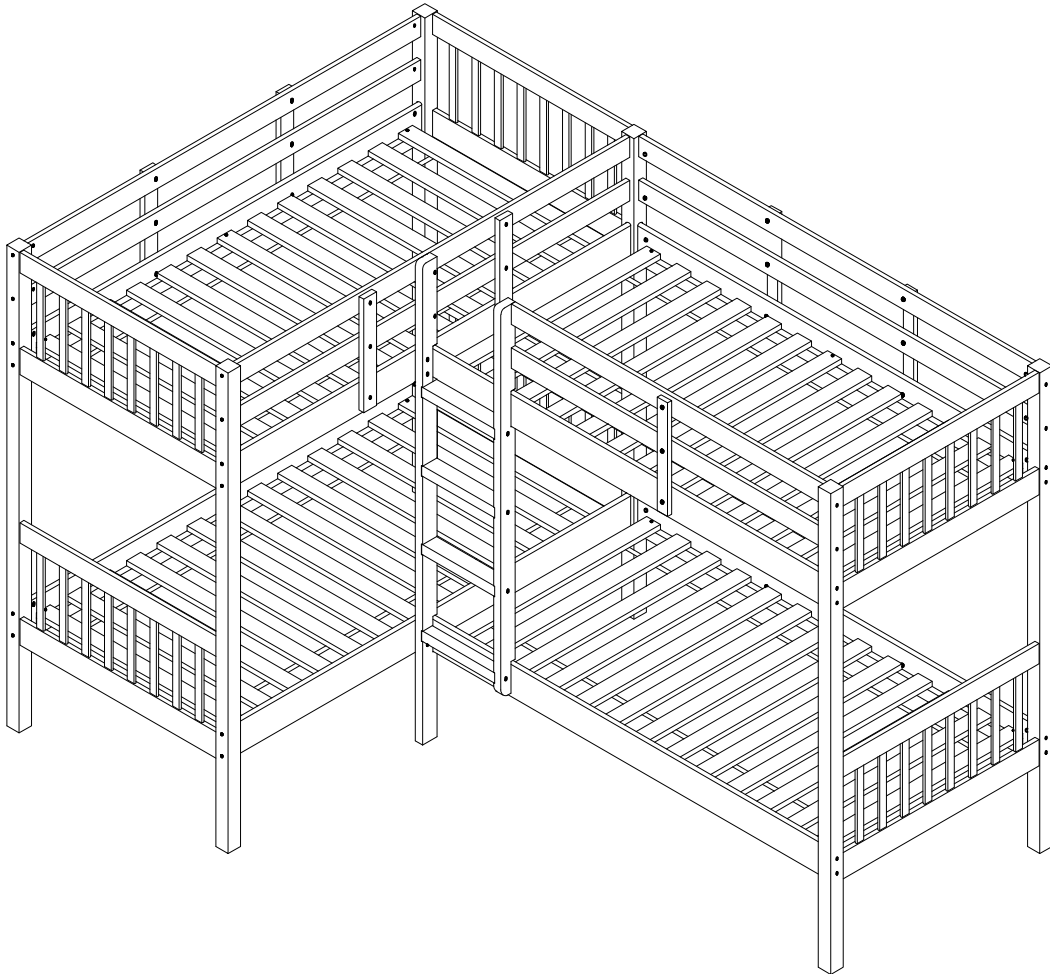

ASSEMBLY COMPLETED



Please ensure the furniture rests on an even and flat surface. If the product wobbles or feels loose, double-check all bolts and/or screws are properly tightened and secured.

✔ **Keep this handy!**

Please retain this instruction manual and any order-related information for future reference.

✔ **Lift, don't drag!**

To avoid damage to product please always LIFT the product when transporting or adjusting the placement.

Safety Warnings for Bunk Beds

1. Read and follow the information on the WARNINGS shown on the end structure of the upper bunk and on the carton.
2. Do not remove warning label from the bed.
3. Keep these instructions for future reference.
4. **IMPORTANT: Must use Bunkie mattress or Bunkie board.** The proper sizes for the **UPPER/LOWER TWIN-SIZE** Bunkie mattress or Bunkie board should be 74" long and 37½" - 38½" wide with no more than 6" thickness and for the **UPPER/LOWER FULL-SIZE** should be 74" long and 53" - 54" wide with no more than 6" thickness.
5. Surface of mattress must be at least 5 inches (127 mm) **BELOW** the upper edge of guardrails.
6. The **MAXIMUM** weight capacity for the upper bunk is not to exceed 175 lbs.
7. Do not allow children under 6 years of age to use the upper bunk.
8. Periodically check and ensure that the guardrails, ladder, handle and other components are in their proper position, free from damage, and that all connectors are tightened and secured.
9. **DO NOT** allow horseplay, rough playing or jumping on the beds and do not allow playing or hiding under the beds.
10. Always use the ladder for entering or leaving the upper bunk.
11. Do not use substitute parts. Contact the manufacturer or dealer for replacement parts.
12. Use of a nightlight may provide added safety precaution for a person using the upper bunk.
13. Always use the guardrails on both sides of the upper bunk.
14. If the bunk bed will be placed next to a wall, the guardrail that runs the full length of the bed should be placed against the wall to prevent entrapment between the bed and the wall.
15. The use of water or sleep flotation mattresses is prohibited.
16. No more than one person is allowed on the upper bunk at all times.



WARNING: STRANGULATION HAZARD

Never attach or hang objects to any part of the bunk bed that are not designed for use with the bed. Objects such as hanger, hook, belt, bag, rope, string, etc. should not be used on or around the bunk bed.