

Before assembling this product, please ensure that all the components supplied comply with the list on this page. All Screw-type fittings can be tightened with this tool.

Avant de commencer l'assemblage, veuillez contrôler si tous les objets indiqués sont présents. Tous les vis peuvent être serrés par cet outil.

Bevor Sie mit dem Aufbau beginnen, kontrollieren Sie ob alle auf der Zeichnung angegebenen Teile vorhanden sind. Bitte verwenden Sie zur Montage einen Kreuzschraubzieher und den beiliegenden Innensechskantschlüssel.

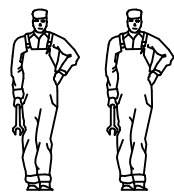

Ware-nr.
Part no.
Réf No

Stck.
Qty.
Qté.

Siehe Bild-nr.
See picture no.
Image no

Mass
Dim.
Dim.

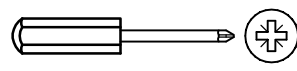
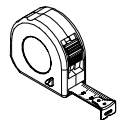

See assembly instruction in box no.

Voir notice de montage dans la caisse no.

Siehe Aufbauanleitung im karton no.

Zie voor de montage-instructie pakketnr.

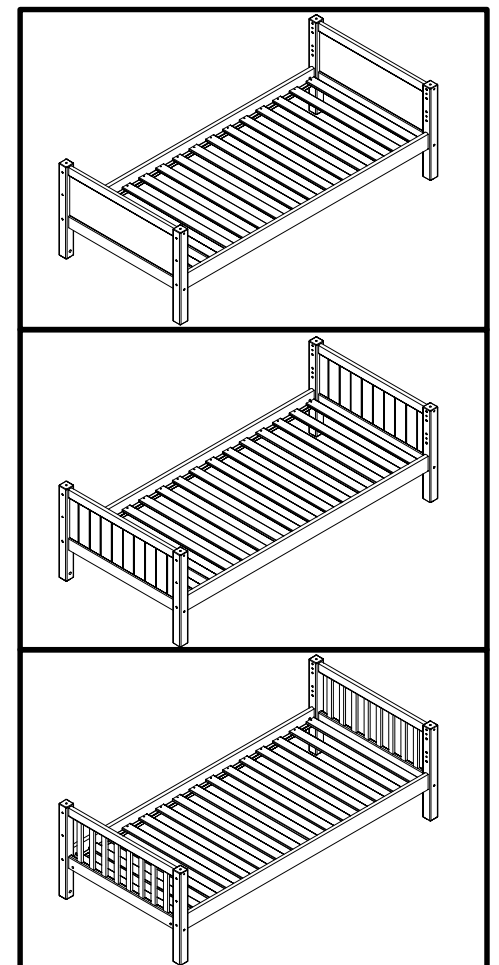

| | | | |
|--|--|--|--|
| <p>A</p> <p>4 stck/pcs. 318x65x26</p> | <p>D</p> <p>2 stck/pcs. 1833x89x26</p> | <p>F</p> <p>3 stck/pcs. 1967x89x26</p> | <p>G</p> <p>2 stck/pcs. 1186x63x63</p> |
| <p>B</p> <p>1 stck/pcs. 361x65x26</p> | <p>E</p> <p>2 stck/pcs. 863x89x26</p> | <p>H</p> <p>2 stck/pcs. 1186x63x63</p> | <p>Z6</p> <p>28 stck/pcs. ø8 mm.</p> |
| <p>C</p> <p>2 stck/pcs. 3930-10050 20 stck/pcs.</p> | <p>Z3</p> <p>16 stck/pcs. 3909-70100 ø7x100 mm.</p> | <p>Z4</p> <p>6 stck/pcs. 3901-40030 ø4x30 mm.</p> | <p>Z8</p> <p>4 stck/pcs. 3938-00016-2 ø16 mm.</p> |

| | |
|---|--|
| <p>Z7</p> <p>12 stck/pcs. 3938-00010-2 ø10 mm.</p> | <p>Z9</p> <p>4 stck/pcs. 3903-40025 ø4x25 mm.</p> |
|---|--|

| | | | | |
|--|---|---|--|--|
| <p>Z2</p> <p>20 stck/pcs. 3930-10050 ø10x50 mm.</p> | <p>Z10</p> <p>4 stck/pcs. 3907-63022 ø6,3x22 mm.</p> | <p>Z11</p> <p>4 stck/pcs. 3917-10012 M10x12 mm.</p> | <p>Z12</p> <p>2 stck/pcs. 4007-014 15,5x3 mm.</p> | <p>Z13</p> <p>4 stck/pcs. 4008-021 20x20x16x2 mm.</p> |
| <p>Z14</p> <p>4 stck/pcs. 3922-10028 M10/ø15x28 mm.</p> | <p>Z15</p> <p>18 stck/pcs. 3909-70060 ø7x60 mm.</p> | <p>Z16</p> <p>4 stck/pcs. 3934-10115 M10/ø10x115 mm.</p> | <p>Z17</p> <p>4 stck/pcs. 3933-15028 ø15x28 mm.</p> | <p>Z18</p> <p>2 stck/pcs. 3901-30020 ø3x20 mm.</p> |

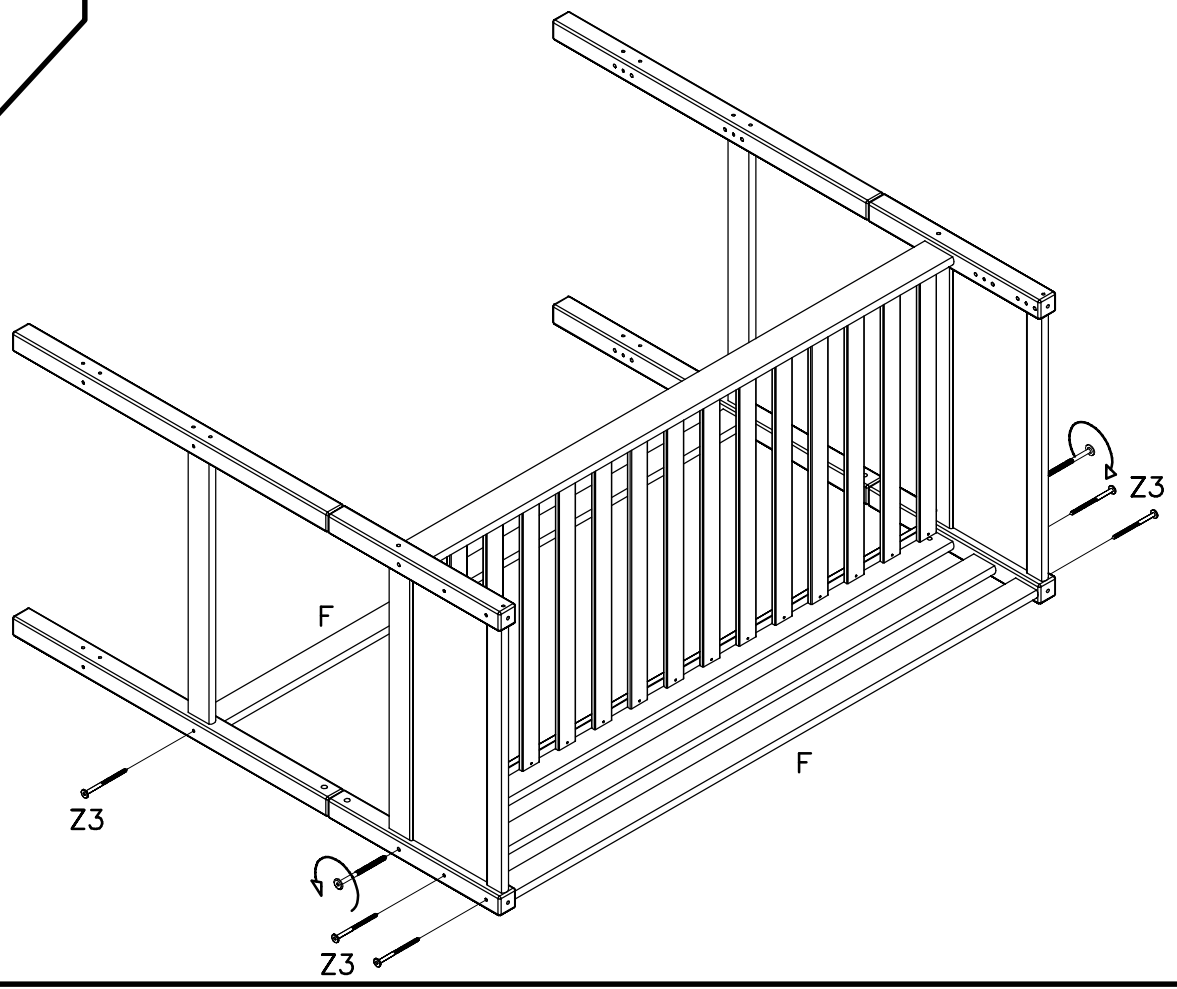
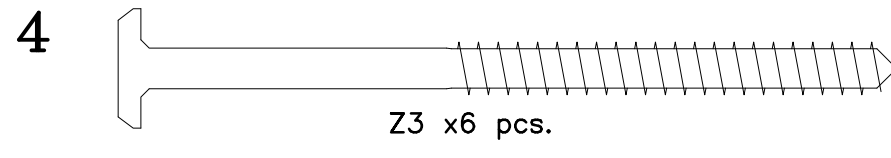
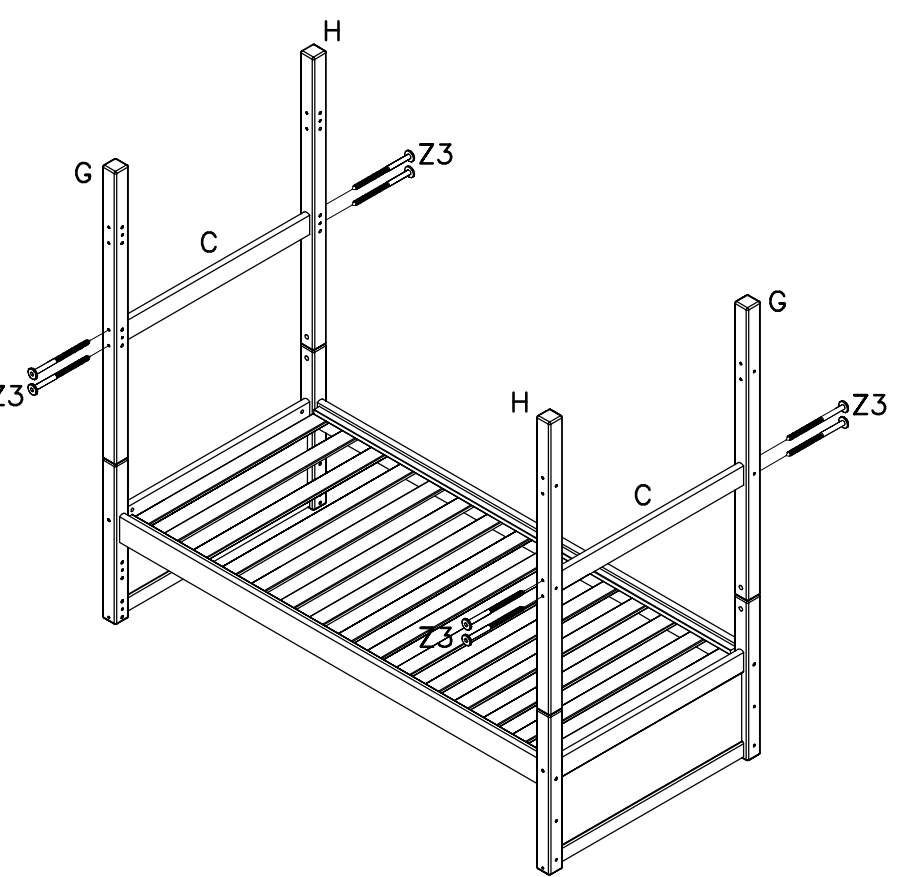
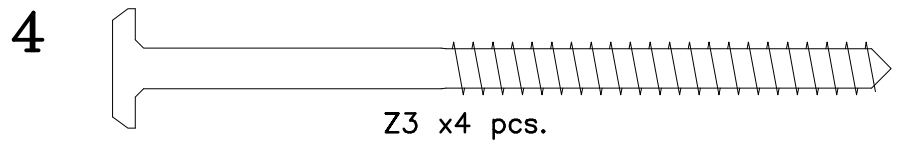
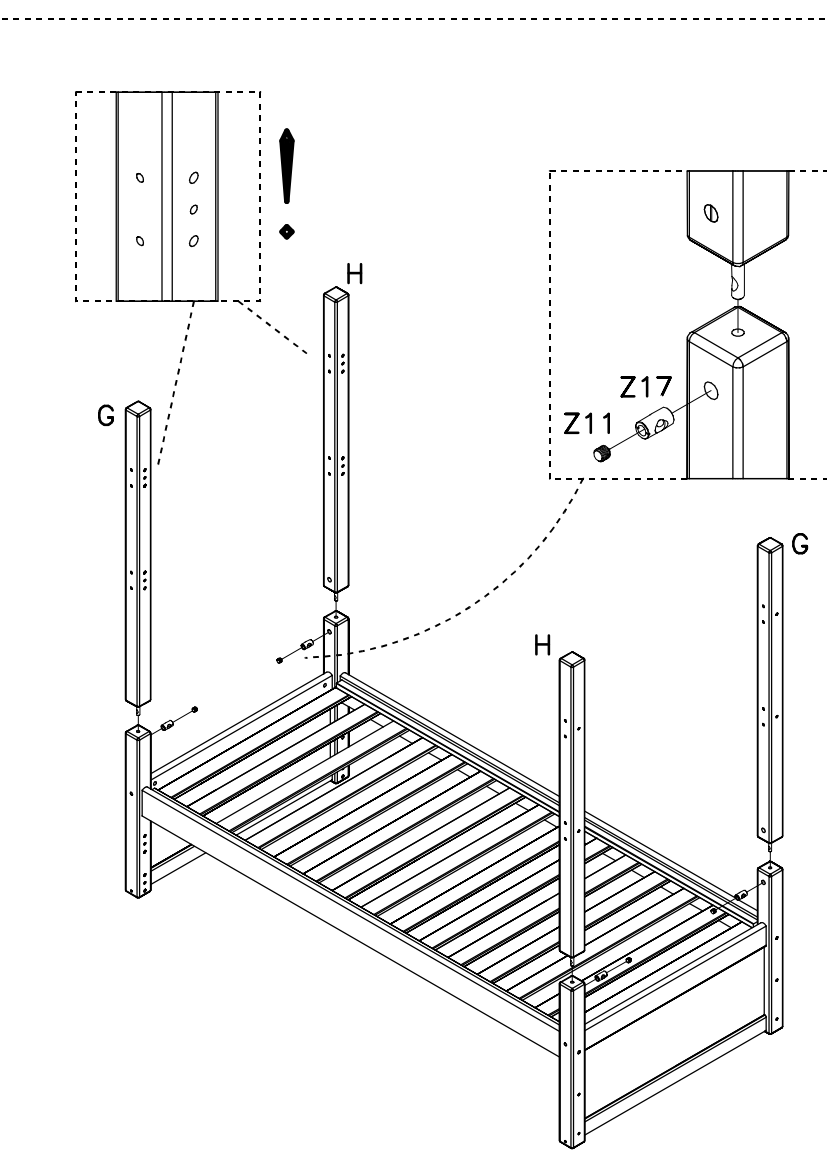
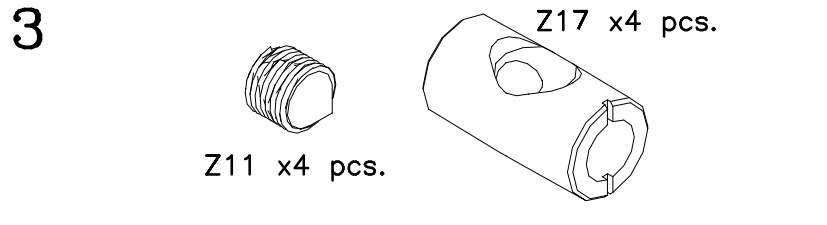
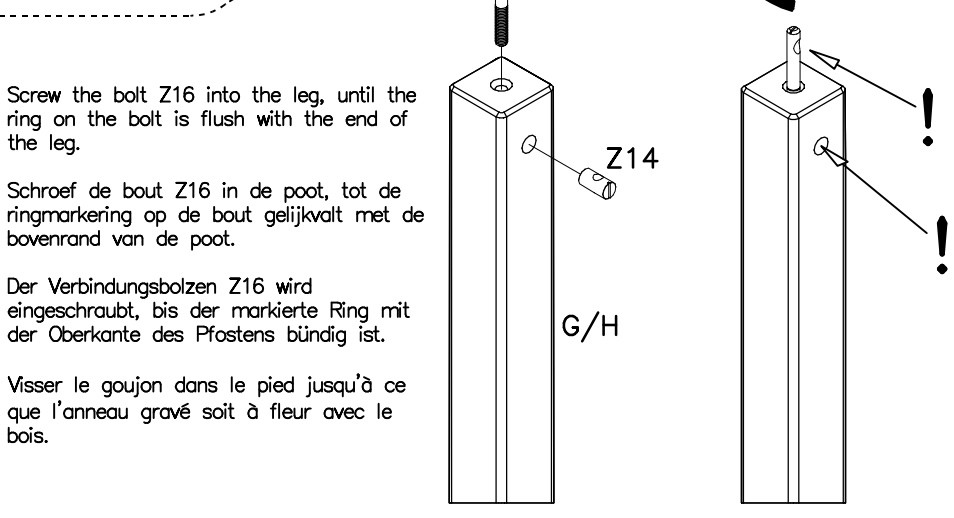
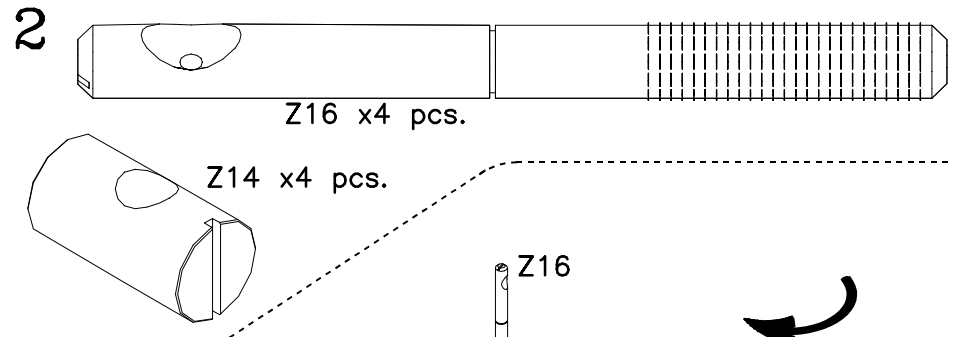
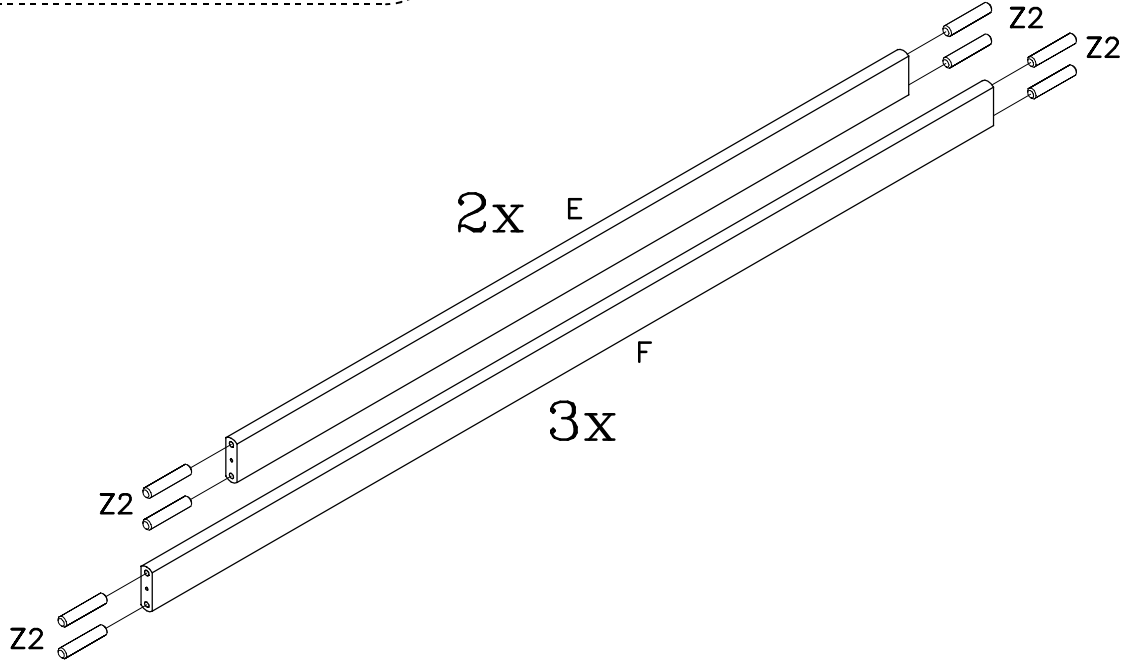
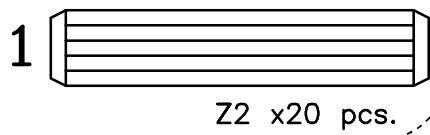

If the leg is loose after assembly, loosen the screw Z11 slightly, until the lower leg can be turned 1 time around clockwise. Then tighten the Z11 screw again.

Indien de poot na montage niet vast genoeg zit, dient u schroef Z11 iets los te draaien, tot de onderste poot 1 keer rechtsom gedraaid kan worden. Daarna kunt u schroef Z11 weer vastschroeven.

Wenn die Pfosten nicht fest genug angezogen sind, muss die Schraube Z11 leicht gelöst werden, bis der untere Pfosten 1 Mal rechts herum gedreht werden kann. Dann muss die Schraube Z11 wieder gespannt werden.

Si les deux montants de pied ne sont pas suffisamment serrés, il convient de desserrer légèrement la vis Z11, jusqu'à pouvoir tourner la partie inférieure du pied 1 fois dans le sens des aiguilles d'une montre. Ensuite reserrer la vis Z11.

6

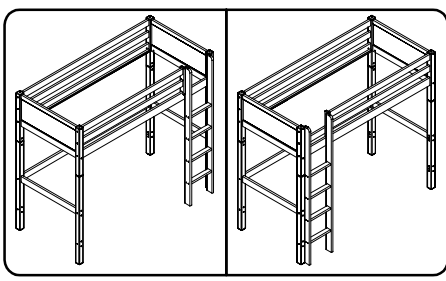
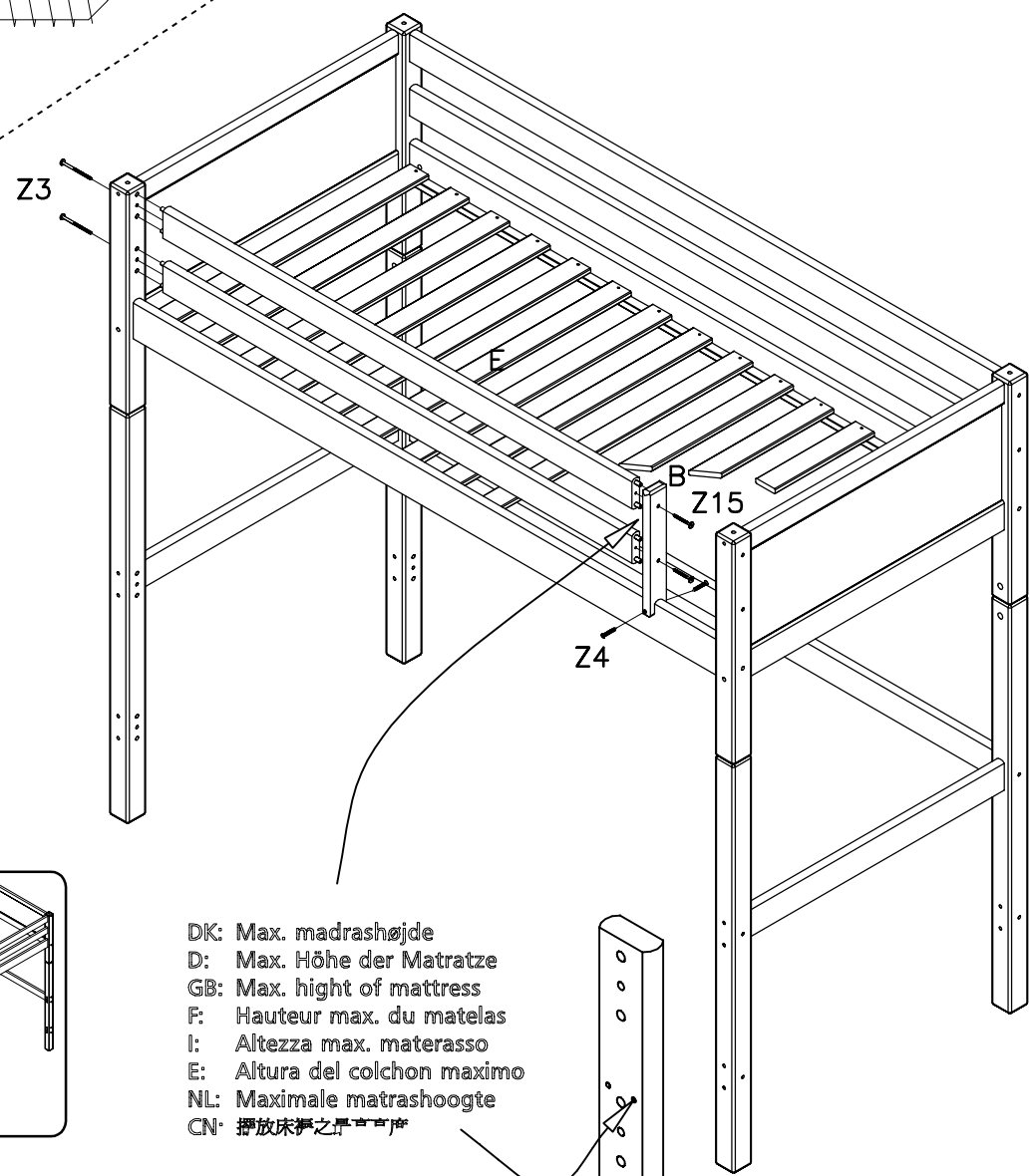
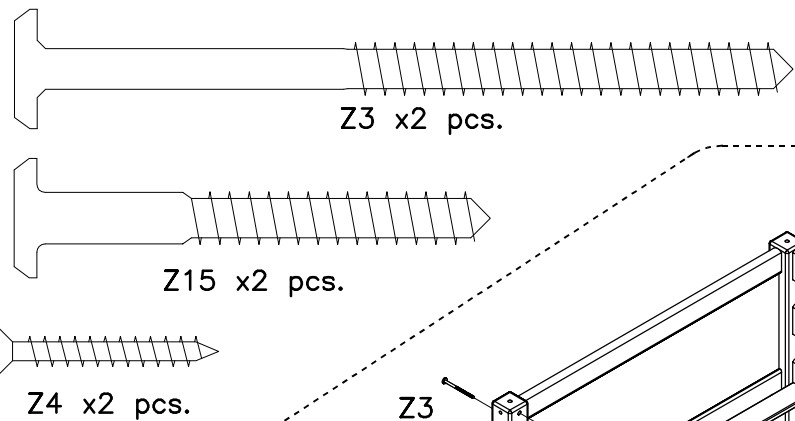

DK: Max. madrashøjde
 D: Max. Höhe der Matratze
 GB: Max. hight of mattress
 F: Hauteur max. du matelas
 I: Altezza max. materasso
 E: Altura del colchon maximo
 NL: Maximale matrashoogte
 CN: 擲放床褥之最大高度

7

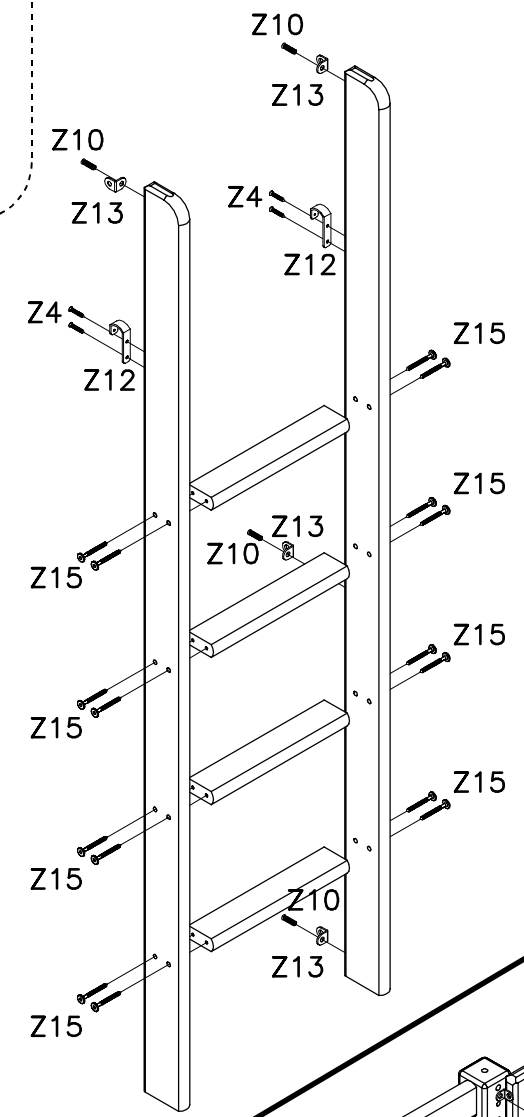
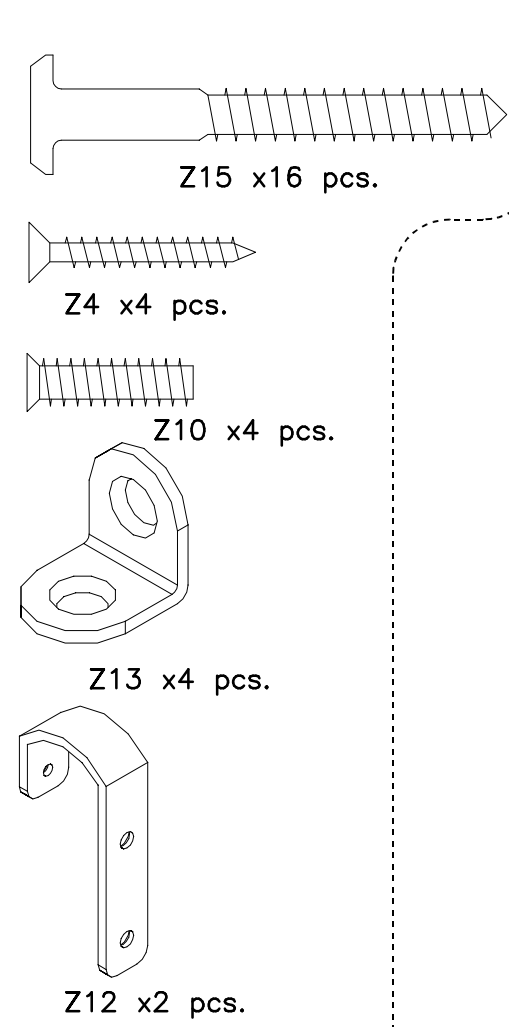

8

