

ASSEMBLY INSTRUCTIONS

TV Cabinet For TV's up to 50"

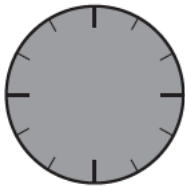

1.0 hr

APPROXIMATE ASSEMBLY TIME



2 PERSON ASSEMBLY

FLOOR AREA
2.0M X2.0M

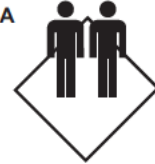

REQUIRED ASSEMBLY SPACE

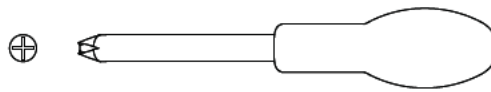





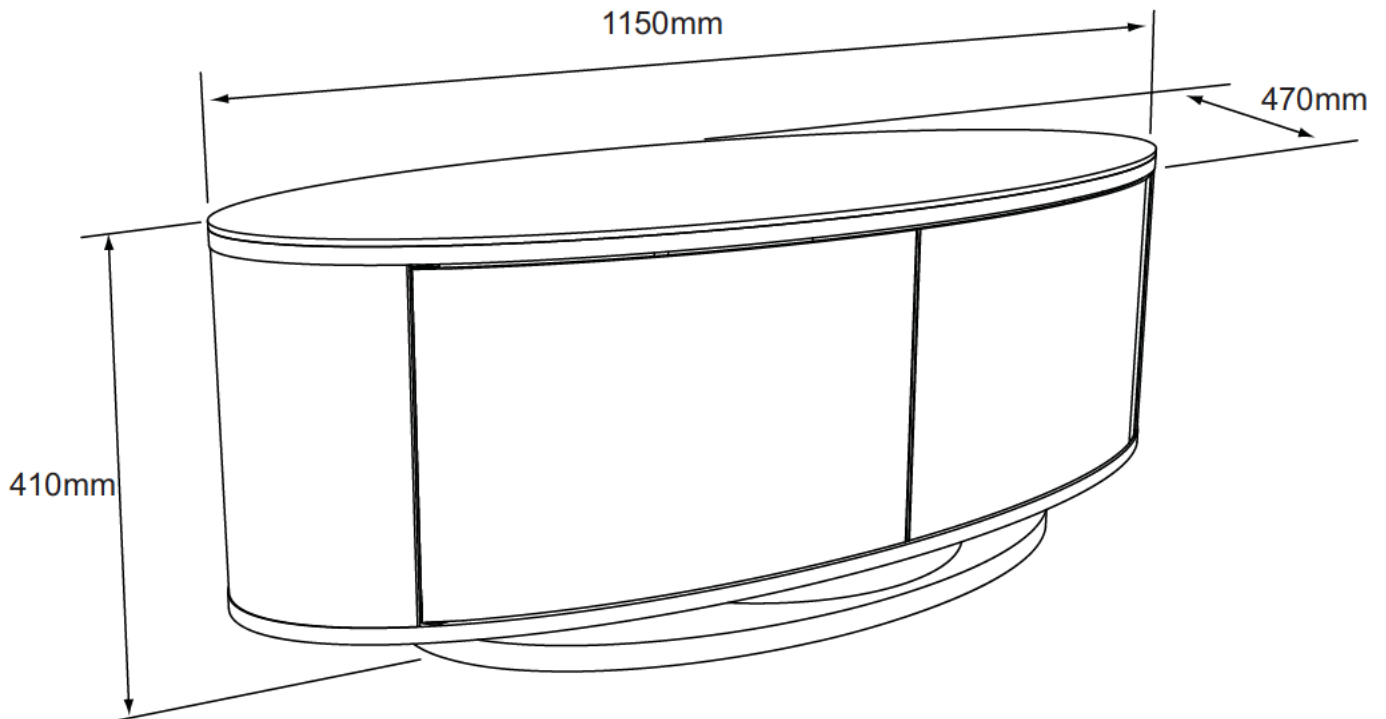



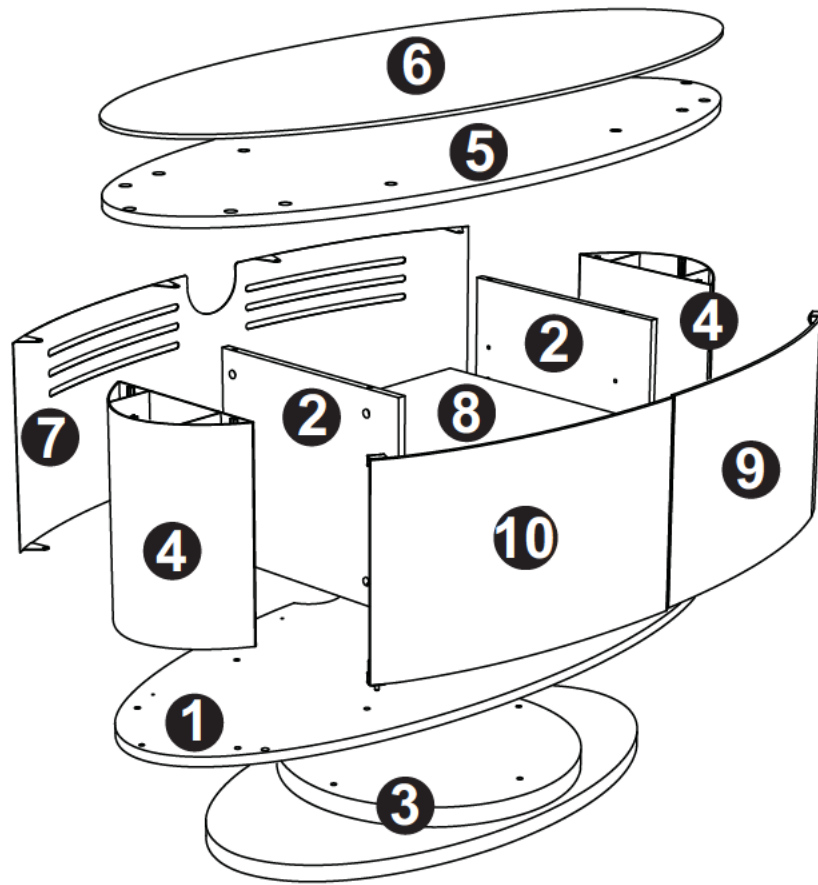

REQUIRED ASSEMBLY TOOLS

ASSEMBLED DIMENSIONS



PARTS LIST



no.		PART LIST	QTY
(1)		BASE PANEL	1
(2)		SIDE PANEL	2
(3)		ROTATING BASE ASSEMBLY	1
(4)		SIDE PROFILE	2
(5)		TOP PANEL	1
(6)		GLASS TOP	1
(7)		REAR PANEL	1
(8)		GLASS SHELF	1
(9)		RIGHT HAND GLASS DOOR	1
(10)		LEFT HAND GLASS DOOR	1

HARDWARE LIST

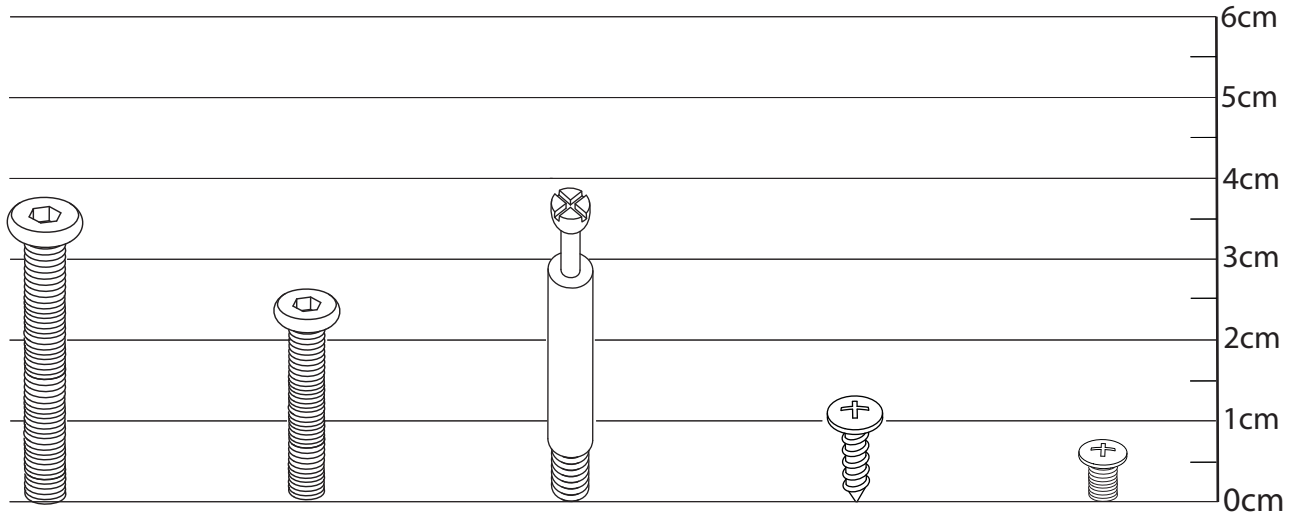

4x

M6 x 35mm

A
BOLT

12x

M6 x 25mm

B
BOLT

8x

M6 x 38mm

C
CAM PIN

12x

M3 x 14mm

D
SCREW

8x

M4 x 5mm

E
SCREW

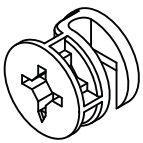

8x

12 x 10mm

F
CAM LOCK



4x

15 x 10mm

G
SHELF PEG

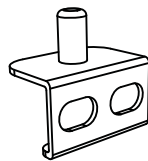

4x

M3 x 14mm

H
DOOR HINGE
PLATE

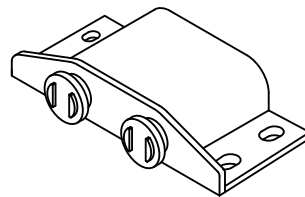

1x

60 x 40 x 20mm

I
DOUBLE MAG
CATCH



1x

M4 x 65mm

J
4mm ALLEN
KEY

Top Tips before you start!

1. Please check that all parts are present before you start the assembly of your furniture.
2. For ease and speed of assembly, we recommend that before you commence each step of the assembly, that you identify all the parts required for that step.
3. For larger items, please ensure that you have sufficient space and people (as indicated on page 1) to assemble your product safely
4. We recommend that, where possible, all items are assembled near to the area in which they will be placed in use, to avoid moving the product unnecessarily once assembled.
5. For the protection of your furniture, particularly items of high gloss finish, we recommend that the product is placed on a protected surface during assembly to prevent any damage.
6. During assembly please take care not to over-tighten any fittings, as this may damage the product.

Care and Maintenance of your Furniture

- Please periodically check all fittings and re-tighten as necessary.
- Please do not sit or stand on this item.
- Never allow any kind of liquid to remain on your furniture, Absorption can cause wood to warp or finishes to de-laminate
- Please do not drag and pull your furniture.
- If the glass is chipped or broken, stop using the product and consult the manufacturer or supplier.
- Please do not place very hot or very cold items on the glass surface, unless adequately thick table mats are used to prevent such items from coming into contact with the glass.
- Please do not use the glass as a chopping surface. Do not strike the glass with hard or pointed items.
- When cleaning glass panels use a damp cloth or leather with washing up liquid or soft soap if necessary, do not use washing powders or any other substances containing abrasives since these substances scratch glass.
- The glass used in this product is toughened and complies with BS EN 12150-1:2000, clauses 8.3 & 8.4

STEP 1

ALIGN THE 4 HOLES IN ALL 3 PANELS TO FIT BOLTS

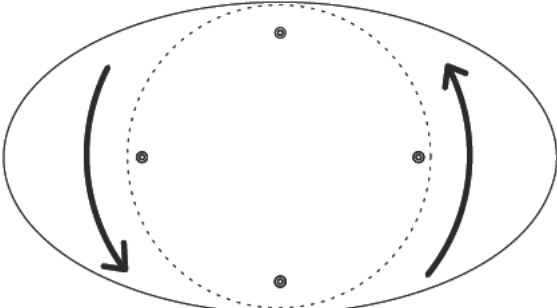
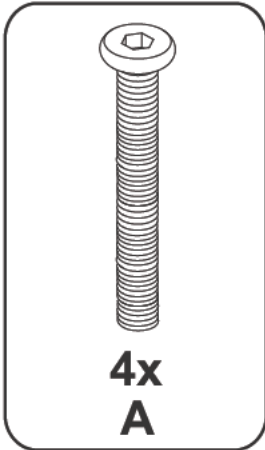
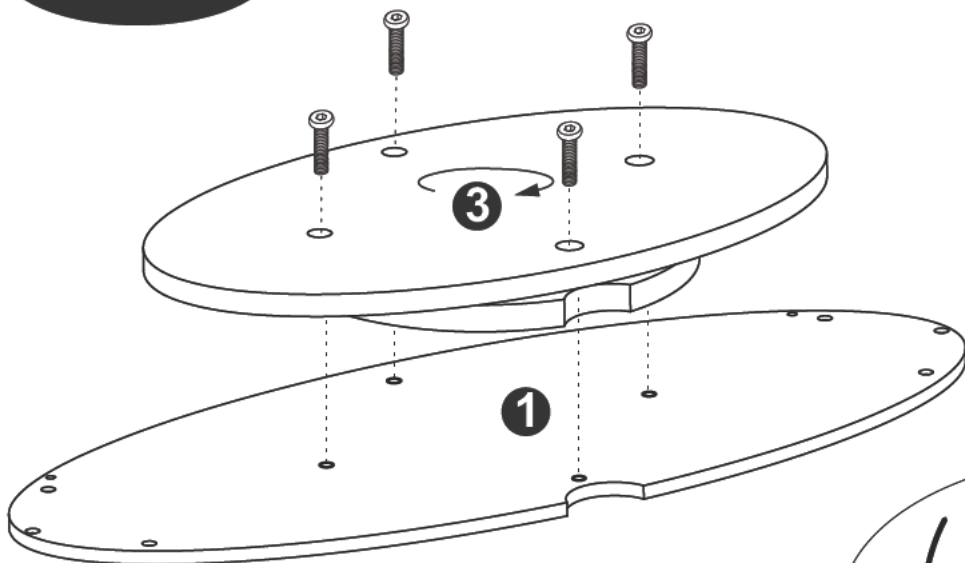

Ensure the 4 holes align to enable fitment of bolts (A) into part 3.

STEP 2

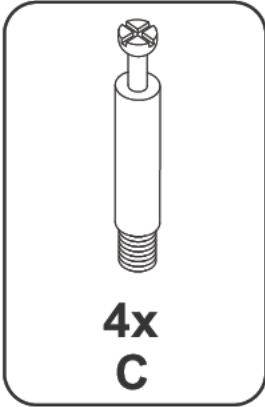
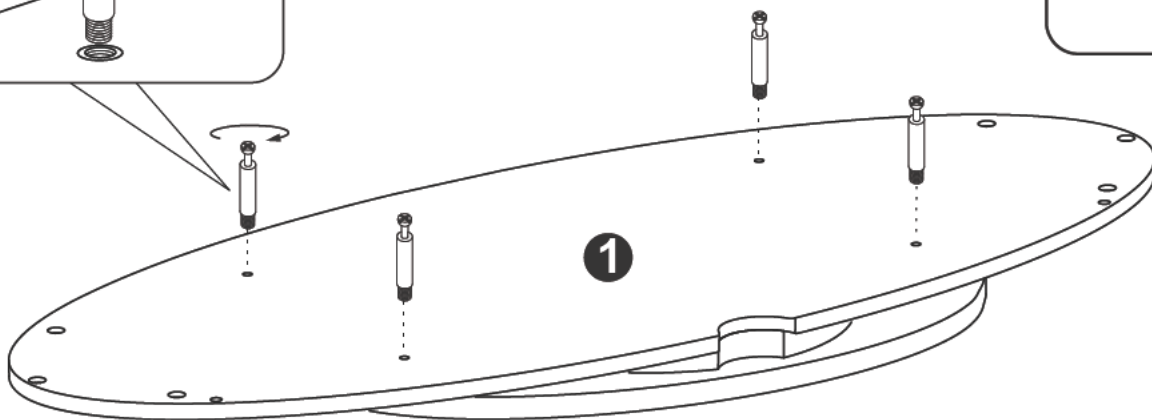
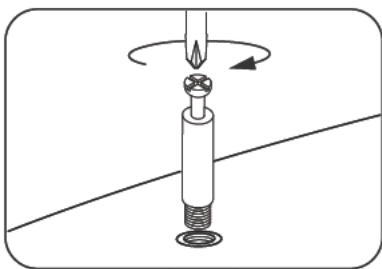

STEP 3

ENSURE PANELS ARE FITTED IN THE CORRECT POSITION.

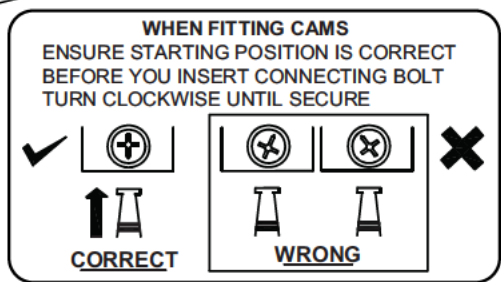
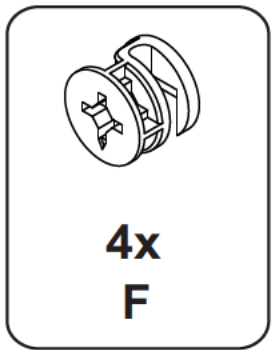
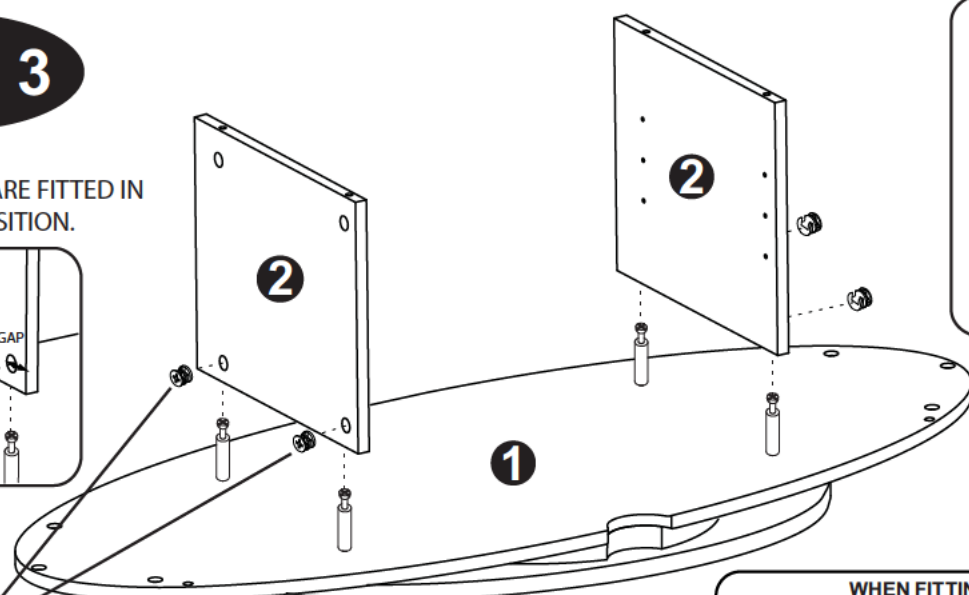
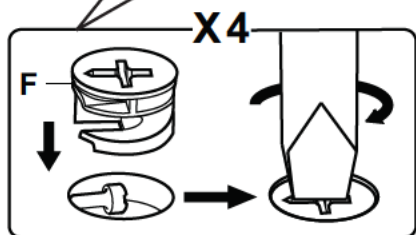
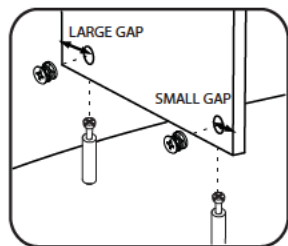

STEP 4

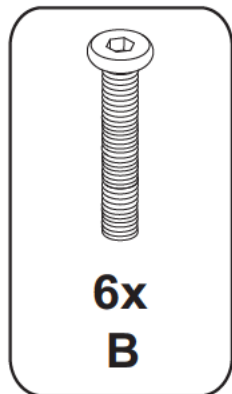
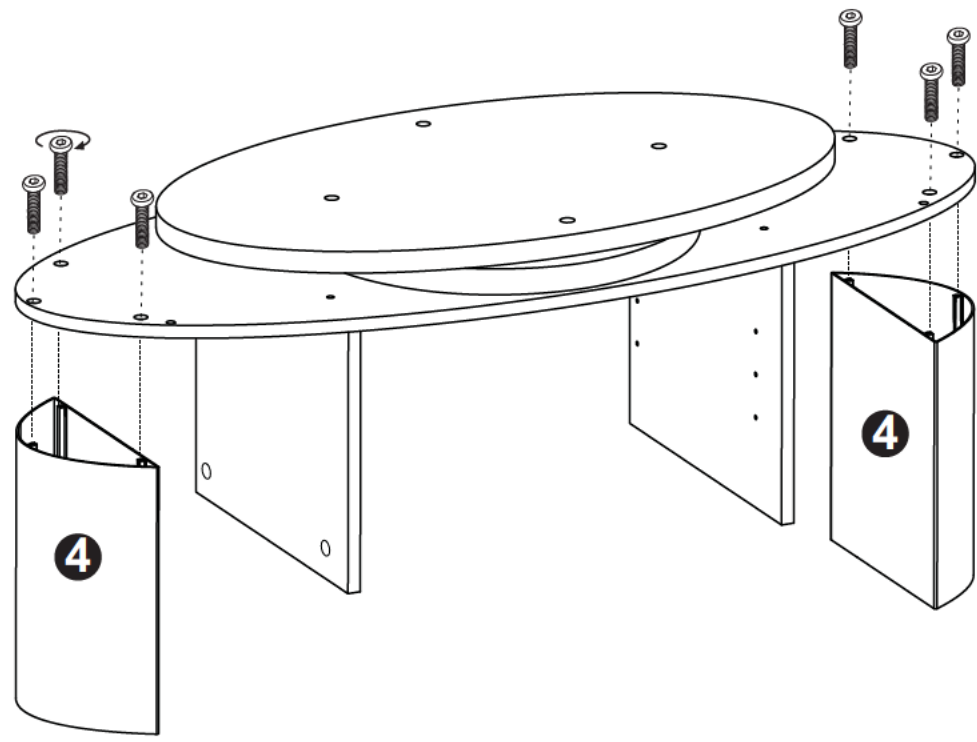

STEP 5

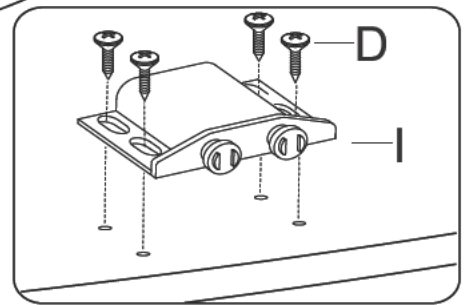
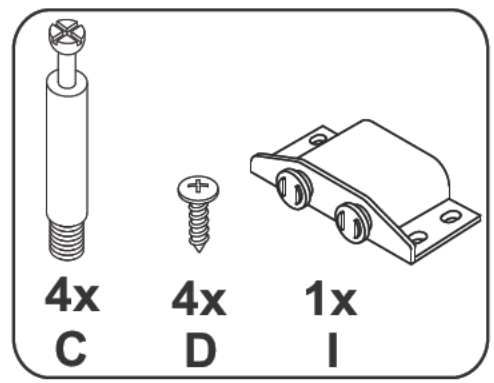
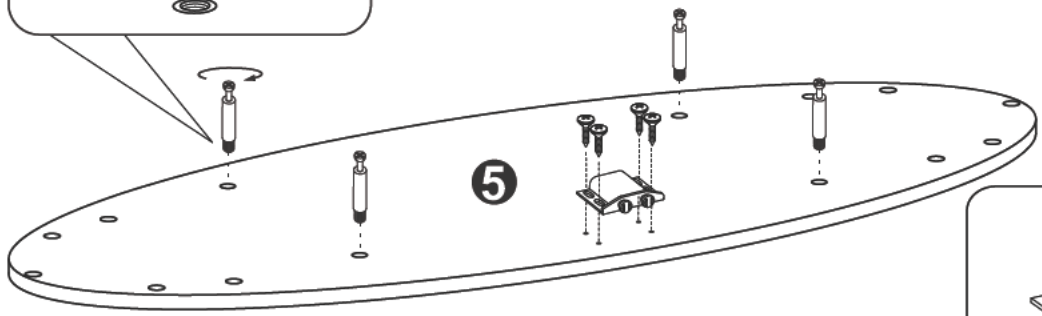
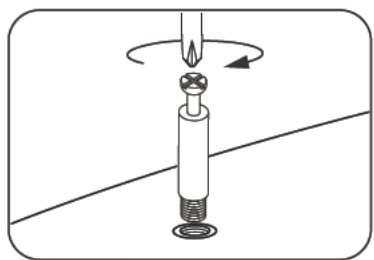

STEP 6

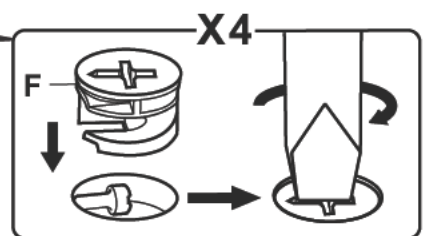
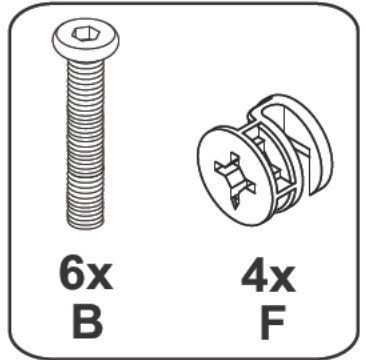
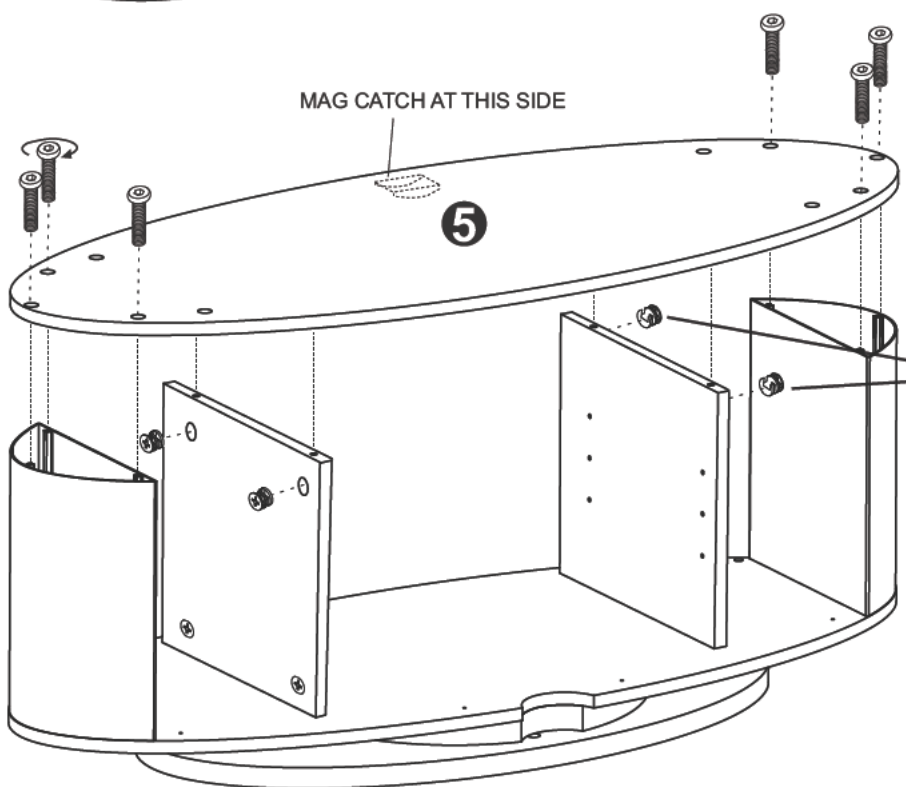

WHEN FITTING CAMS
ENSURE STARTING POSITION IS CORRECT
BEFORE YOU INSERT CONNECTING BOLT
TURN CLOCKWISE UNTIL SECURE

✓				✗
	↑	↑	↑	
	CORRECT	WRONG		

STEP 7

CAREFULLY ALIGN GLASS
TOP & PLACE ONTO CABINET

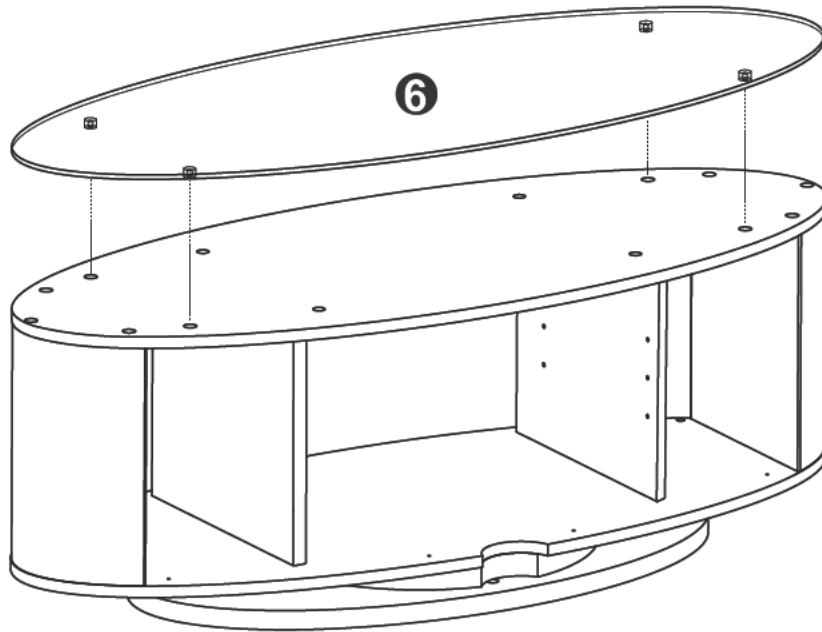

STEP 8

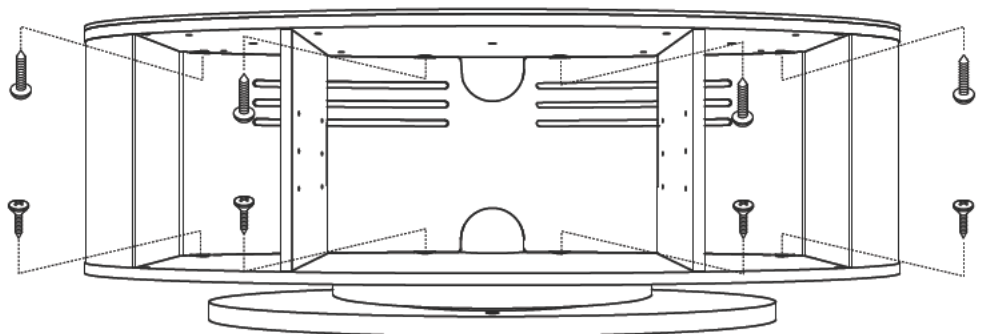
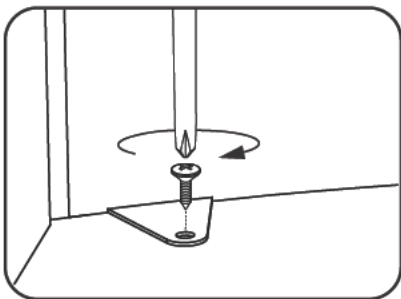
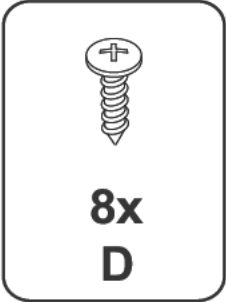
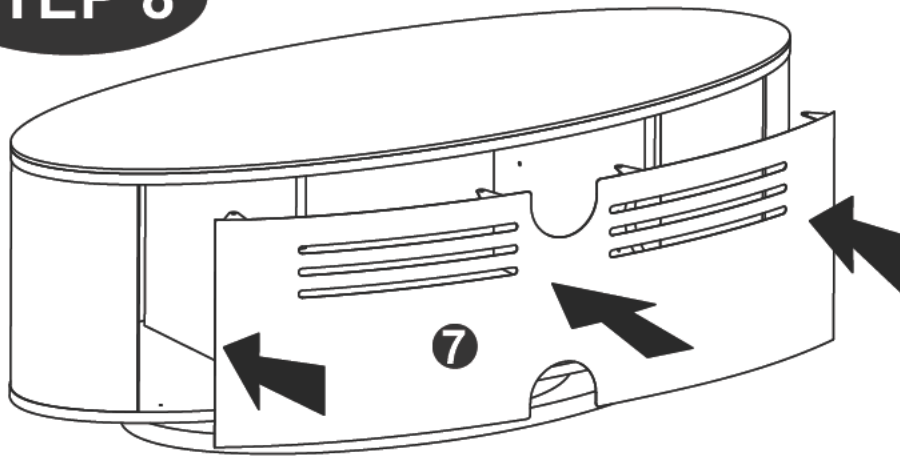

STEP 9

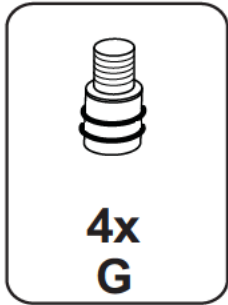
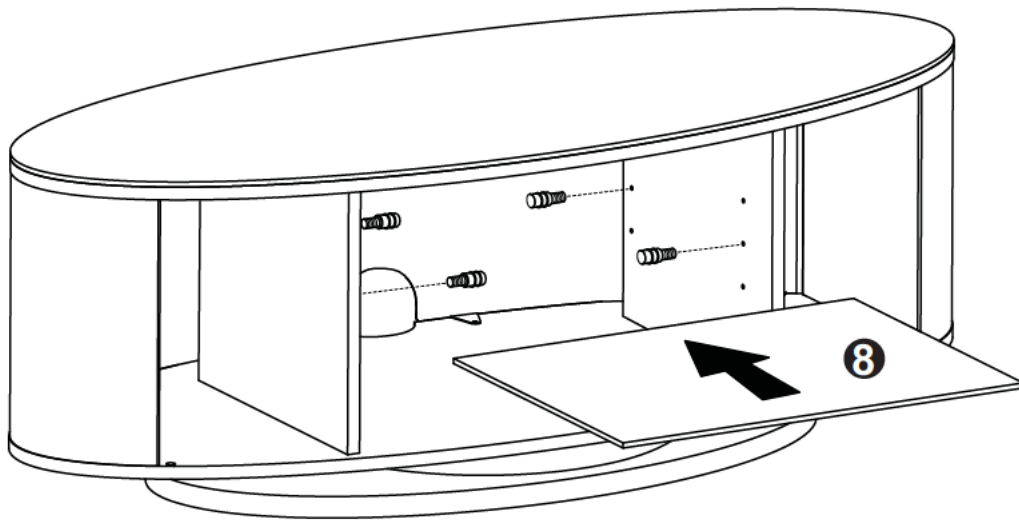

STEP 10

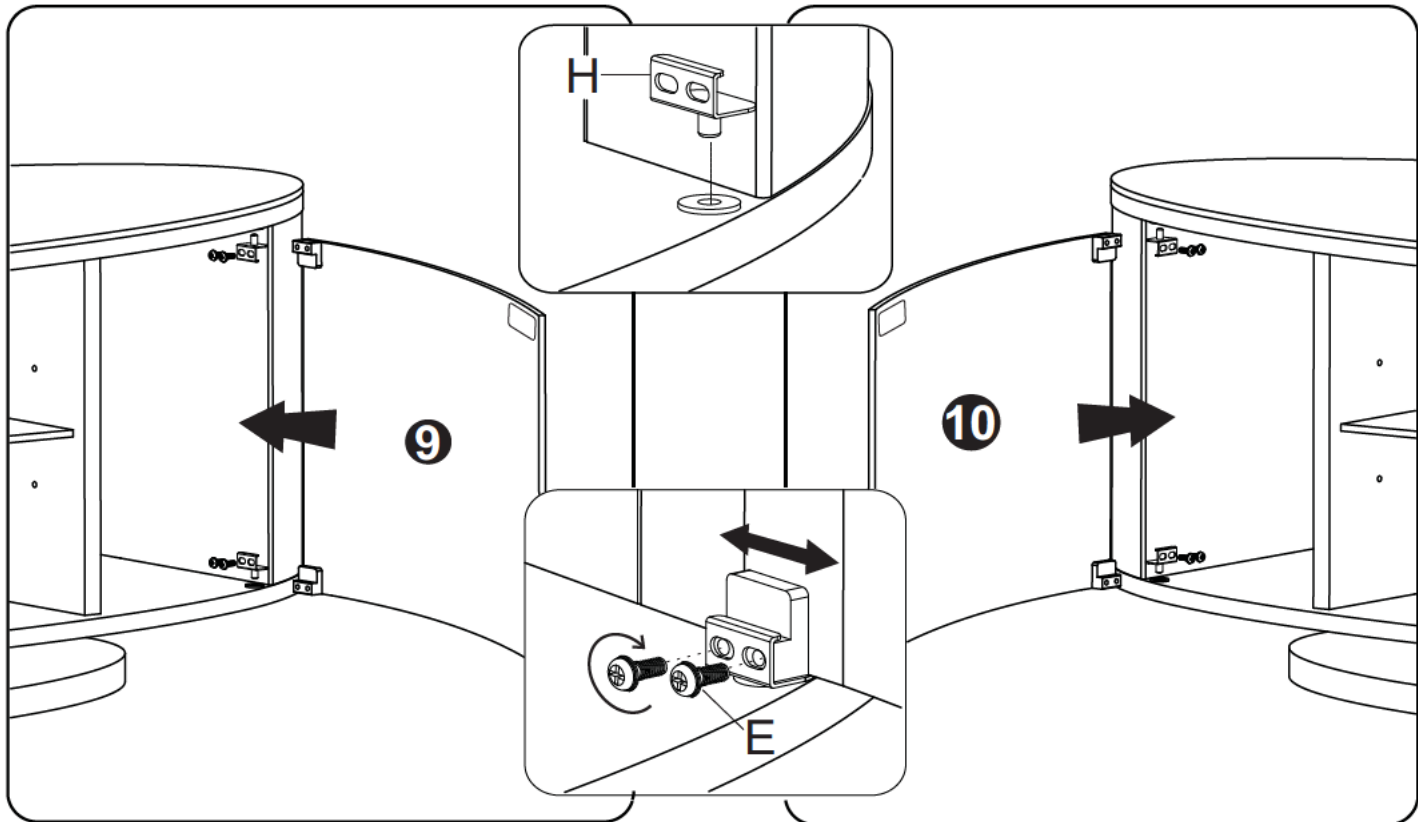
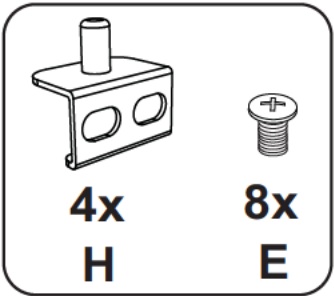

STEP 11

This TV cabinet features 'REMOTE FRIENDLY' glass which allows remote control operation of equipment inside the cabinet with the doors closed. However, if you have a piece of equipment with a poor remote signal (some SKY receivers suffer from this), please position the particular unit on the glass shelf in the middle position. This will then place the unit behind the unprinted window on the glass doors to allow full function of your remote signal.

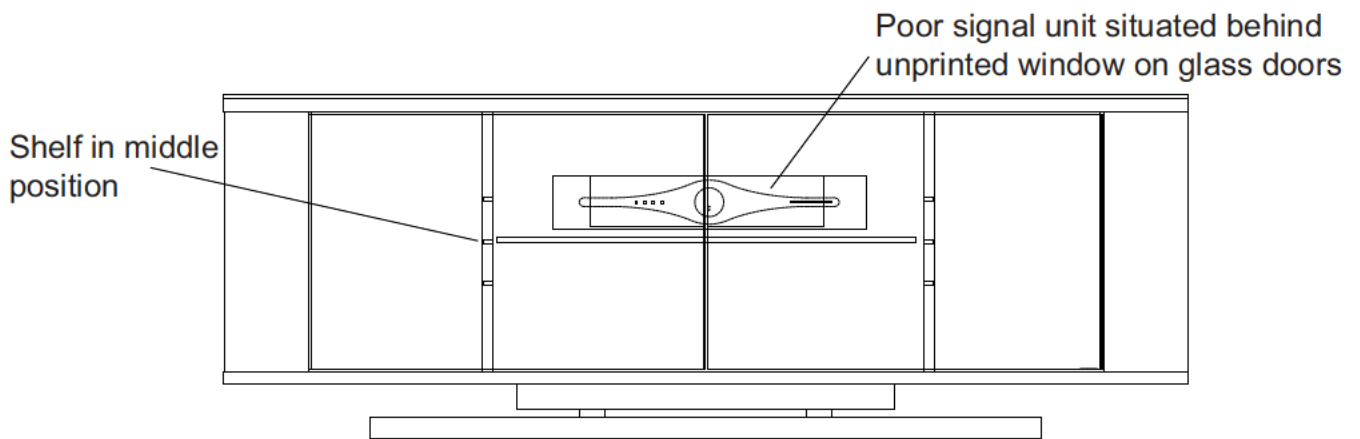

STEP 12

PLEASE ENSURE TV IS SITUATED CENTRALLY ON THE CABINET

