

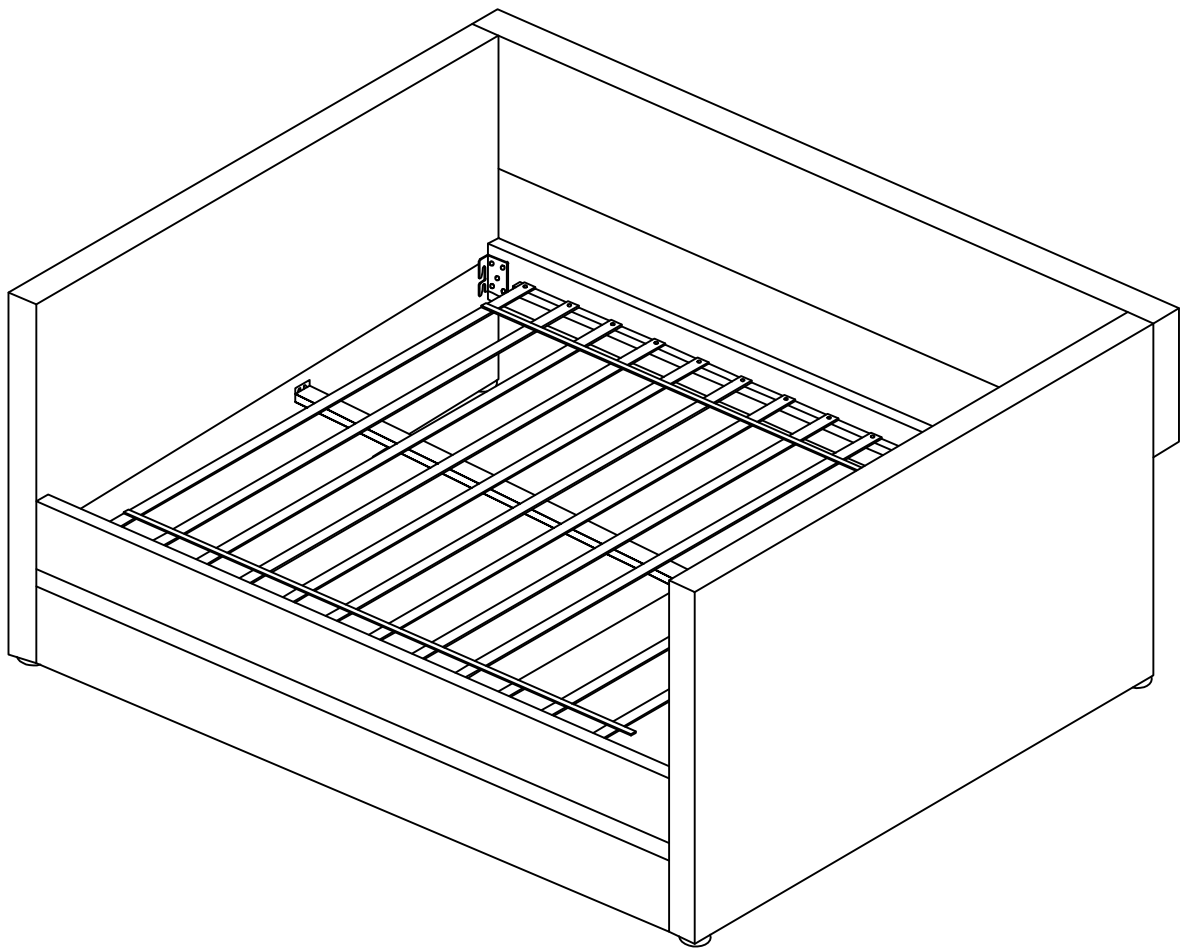











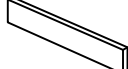





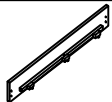

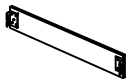
# Installation & Assembly

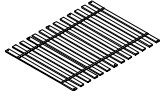

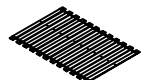
TOOLS REQUIRED

HARDWARE LIST

PARTS LIST:

PARTS LIST:				HARDWARE LIST			
NO	Description	Sketch	Quantity	NO	Sketch	Description	Quantity
1		Arm (L/R)	2PCS	A		Bolt Ø5/16" x 1-1/2"	8PCS
2		Back Rail	1PC	B		Bolt Ø5/16" x 2-1/2"	4PCS
3		Side Rails	2PCS	C		Bolt Ø5/16" x 3/4"	8PCS
4		Front Panel	1PC	D		Lock Washer $\frac{5}{16}$ "	20PCS
5		Back Panel	1PC	E		Flat Washer $\frac{5}{16}$ "x 19mm	16PCS
6		Side Panels	2PC	F		Flat Washer $\frac{5}{16}$ "x 22mm	4PCS
7		Slats (13pcs)	1Set	G		Screw #8 X 1-1/4"	75PCS
8		Slats (12pcs)	1Set	H		Screw #8 X 2"	4PCS
9		Top Center Wood Supportor(Long)	1PCS	I		Allen wrench M5	1PC
10		Bottom Center Wood Supportor (Short)	1PCS				
11		Plastic Feet	4PCS				

Step 1 :

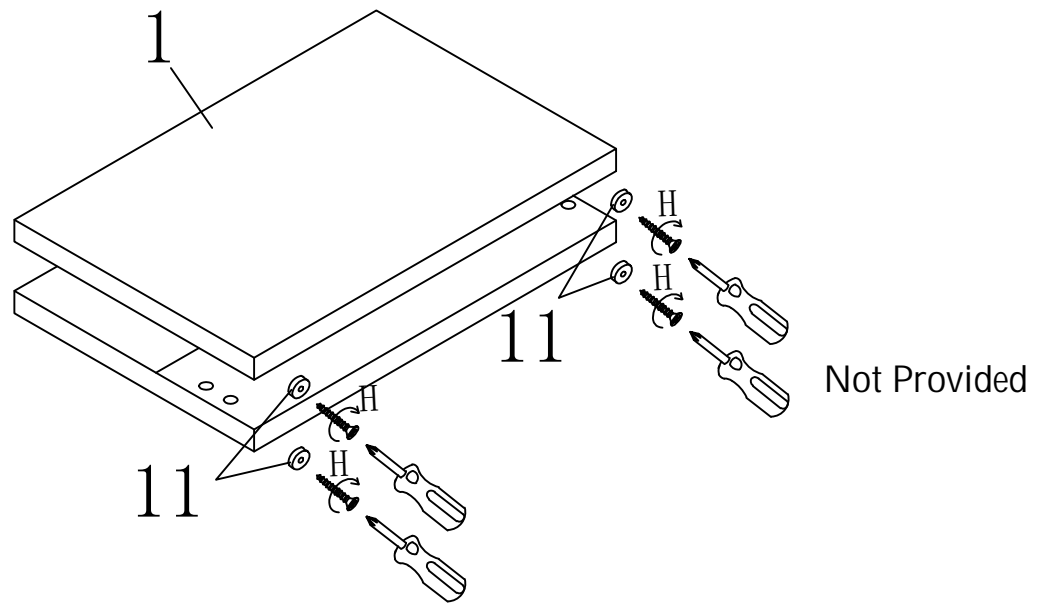

Step 2 :

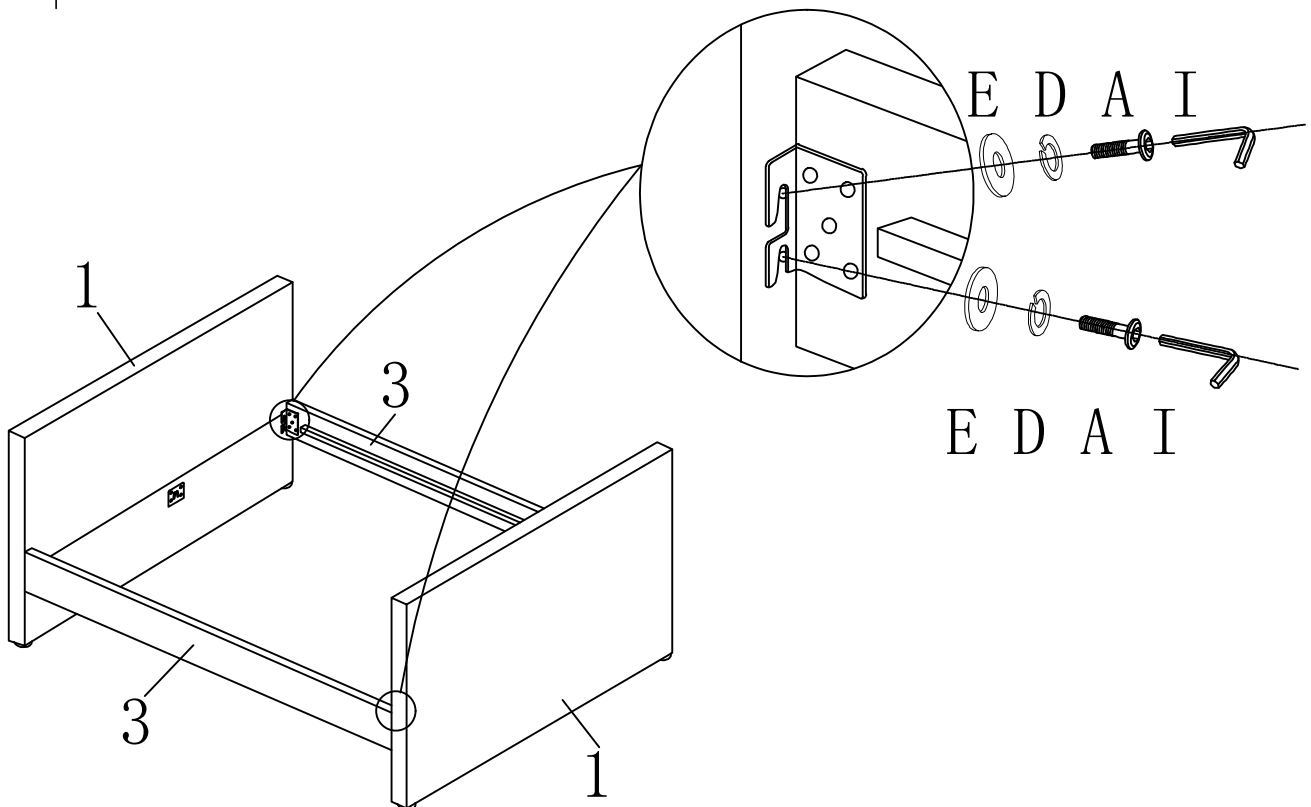

Step 3 : Conect the metal bracket and press down tightly

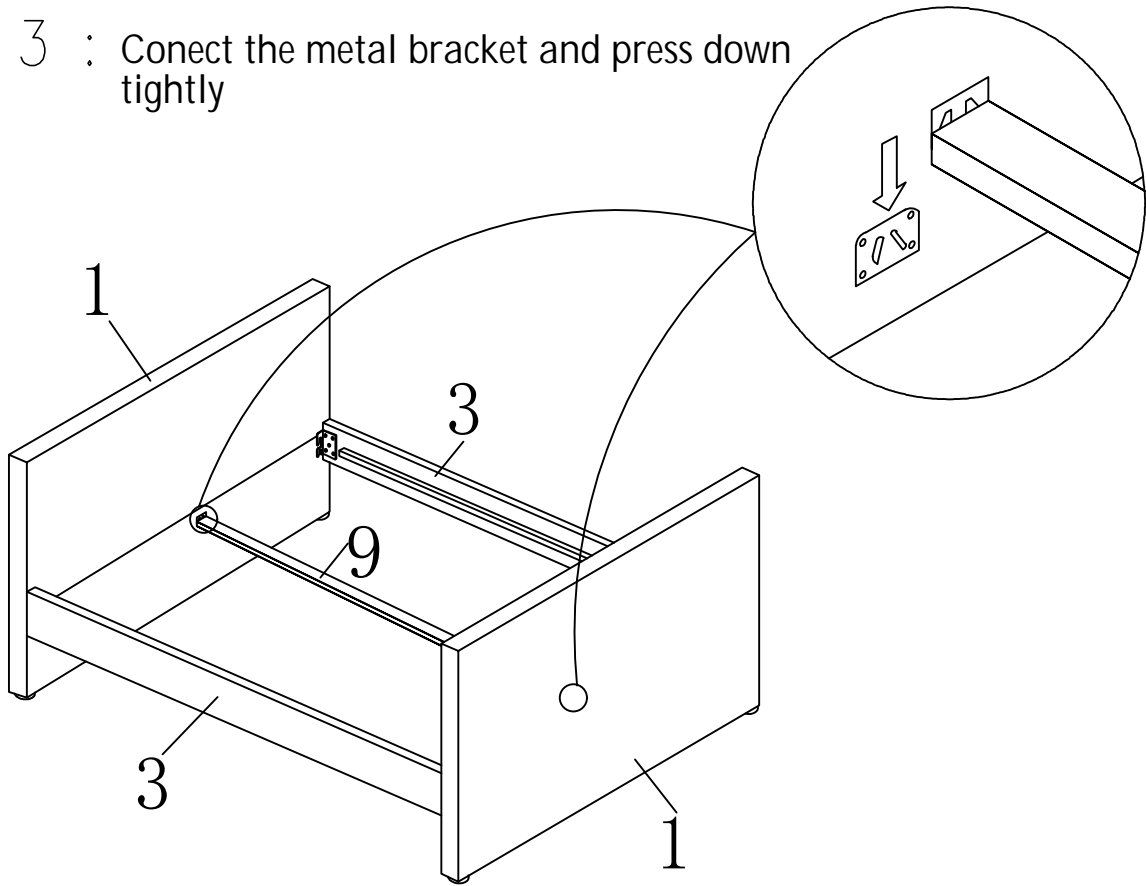

Step 4 :

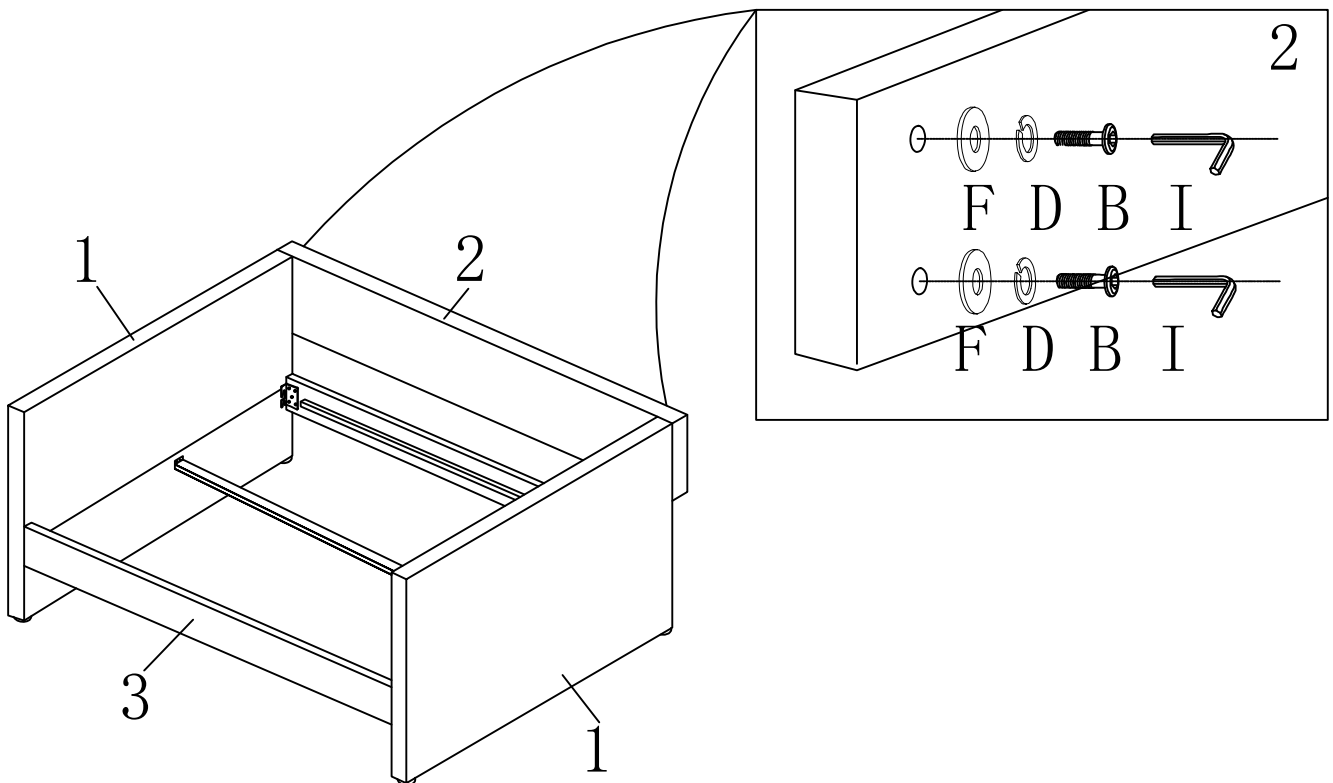

Step 5 :

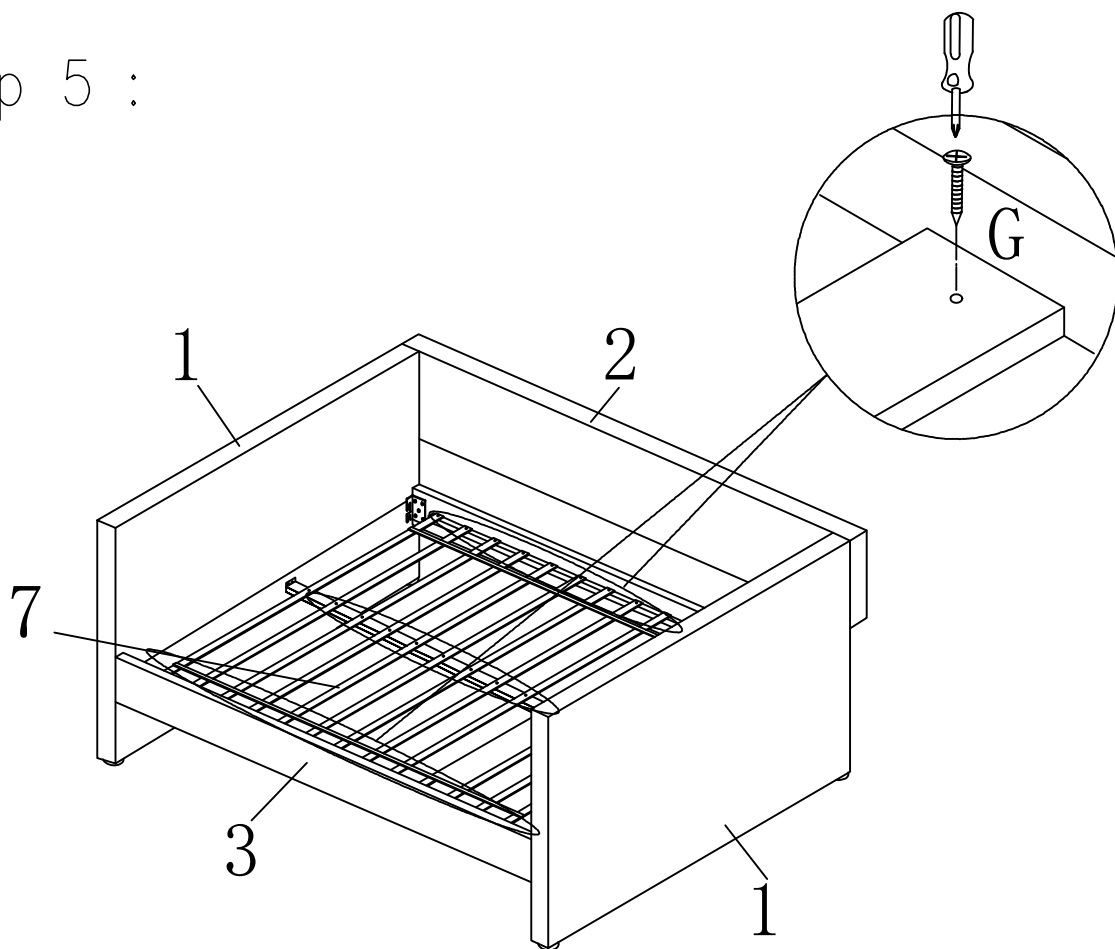

Step 6 :

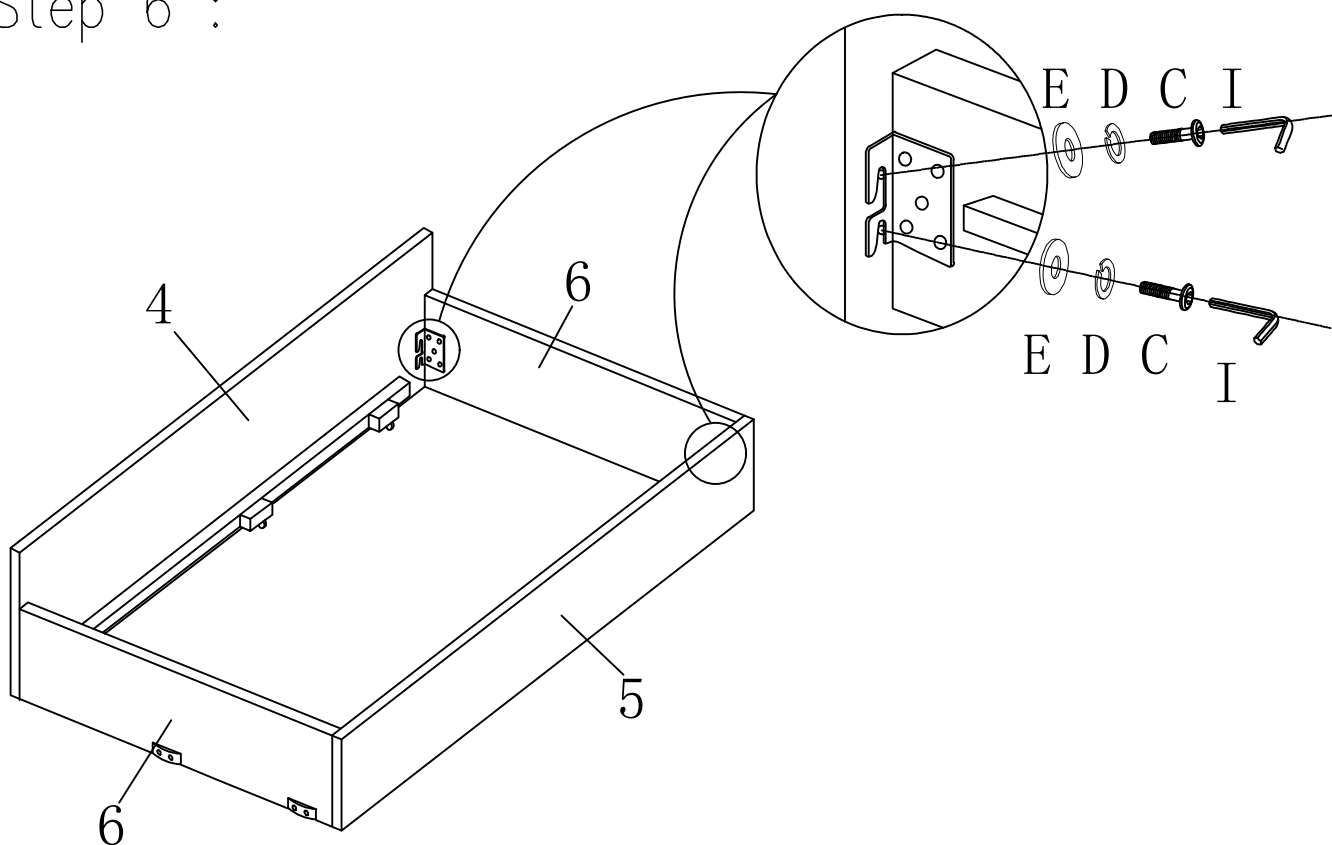

Step 7 :

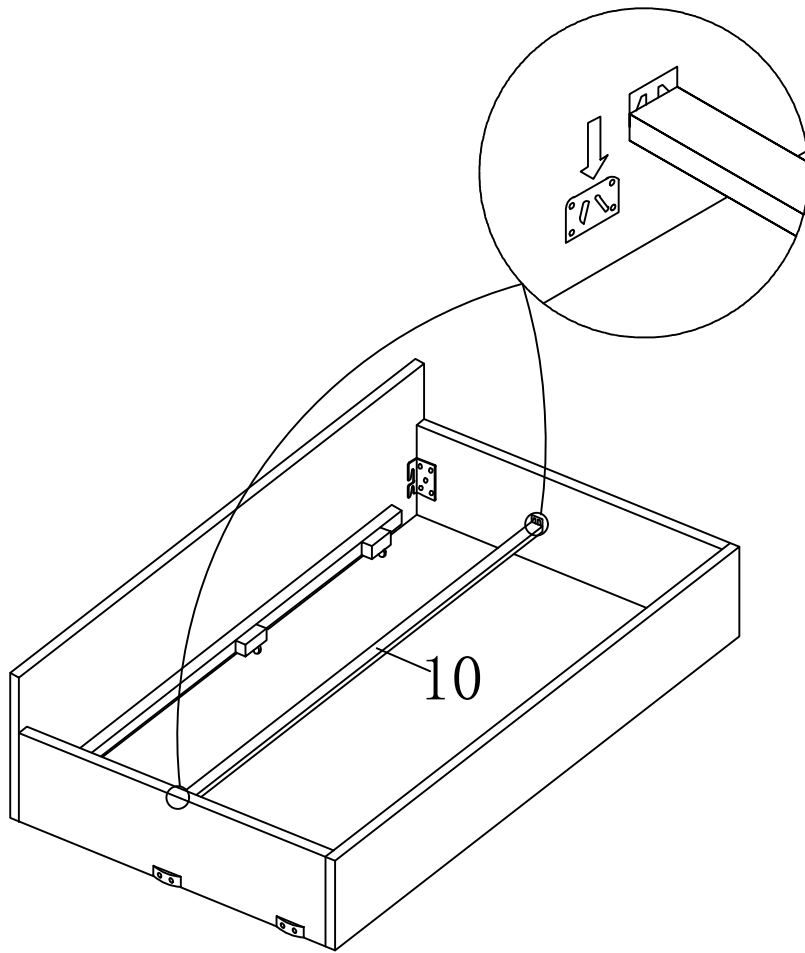

Step 8 :

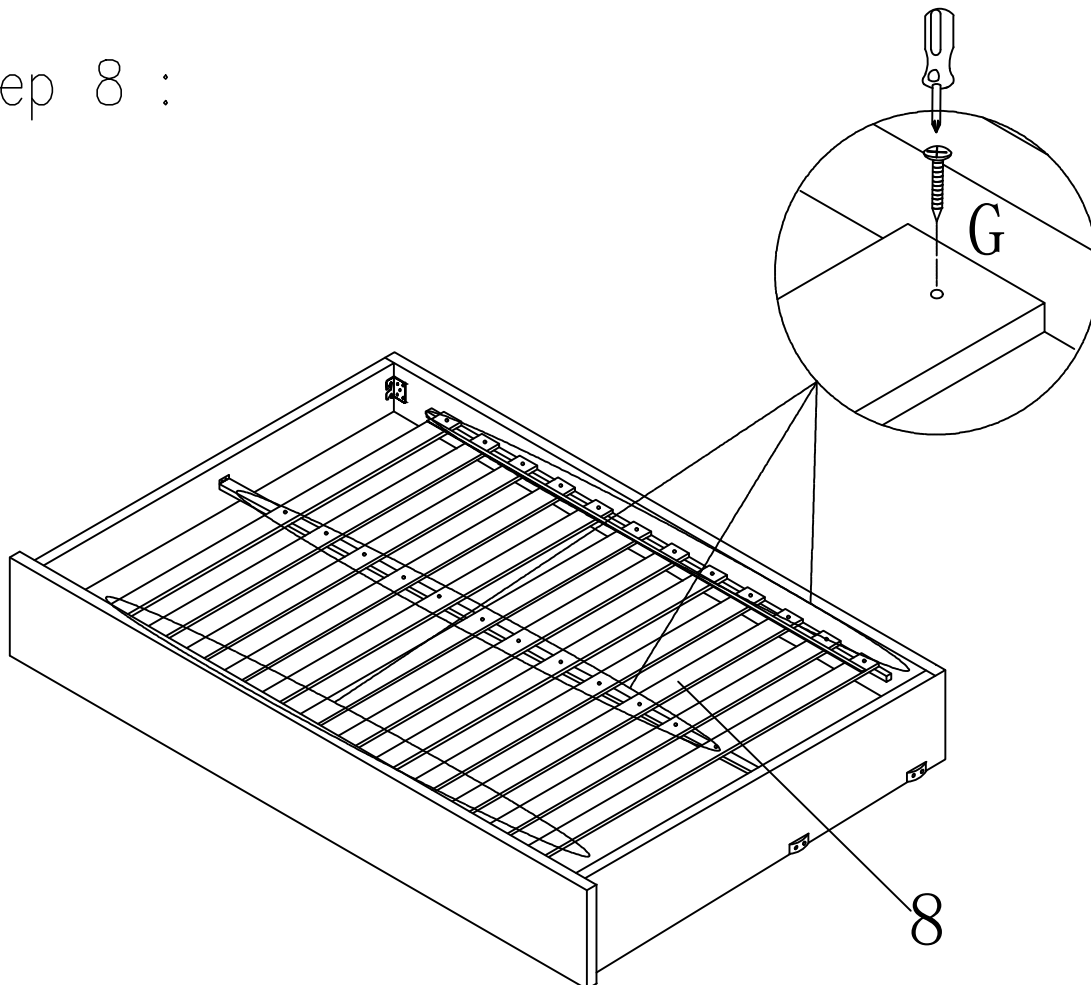

Step 9 :

