





CARE AND MAINTENANCE

Spot clean using a mild water-free solvent. Only a professional cleaner should undertake a complete overall cleaning.
The use of steam or water-based cleaners may cause excessive shrinking or staining.

NOTICE

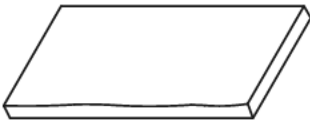
- * Please make sure that you have all parts indicated before you begin assembly of this item.
- * This item should be assembled on a soft surface to prevent scratching the finish during assembly.
- * This item may require periodic tightening.

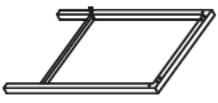
Part List and Hardware List

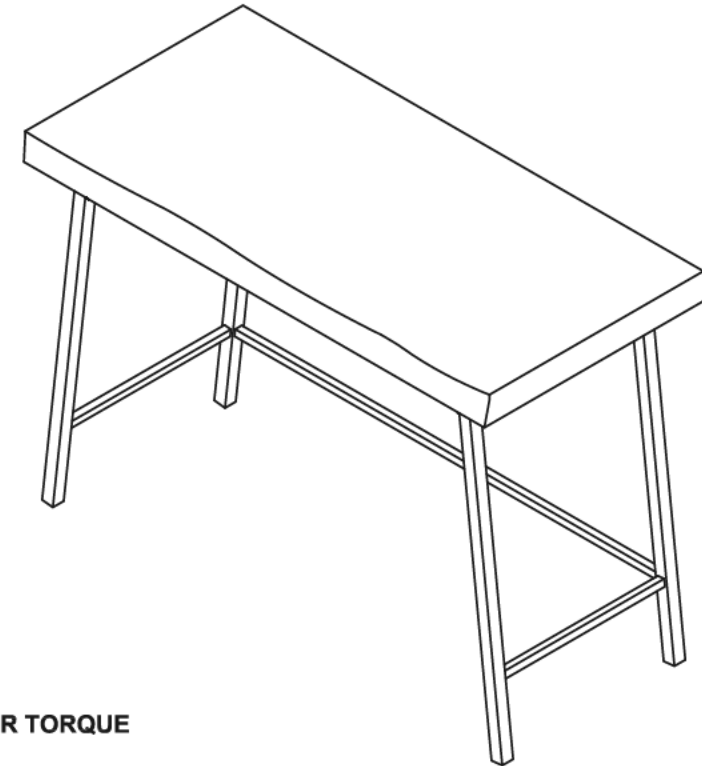

PIECE	DESCRIPTION	PICTURE	QUANTITY
A	TOP PANEL		1X
B	LEFT LEG FRAME		1X
C	RIGHT LEG FRAME		1X
D	TOP FRAME		2X
E	STRETCHER		1X

Product Dimensions: 42"W x 20"D x 30"H



WEIGHT CAPACITY :
TOP : 110 LBS

**WARNING: DO NOT OVER TORQUE
BOLTS/SCREWS**

PIECE	DESCRIPTION	PICTURE	QTY
1	15 MM BOLT	M6x15mm 	20X
2	SPRING WASHER		2X
3	ALLEN KEY		1X

PREPARATION

Before beginning assembly of product, make sure all parts are present. Compare parts with package contents list and hardware contents list.

If any part is missing or damaged, do not attempt to assemble the product.

Estimated Assembly Time: 60 minutes.

Tools Required for Assembly : Phillips Screwdriver

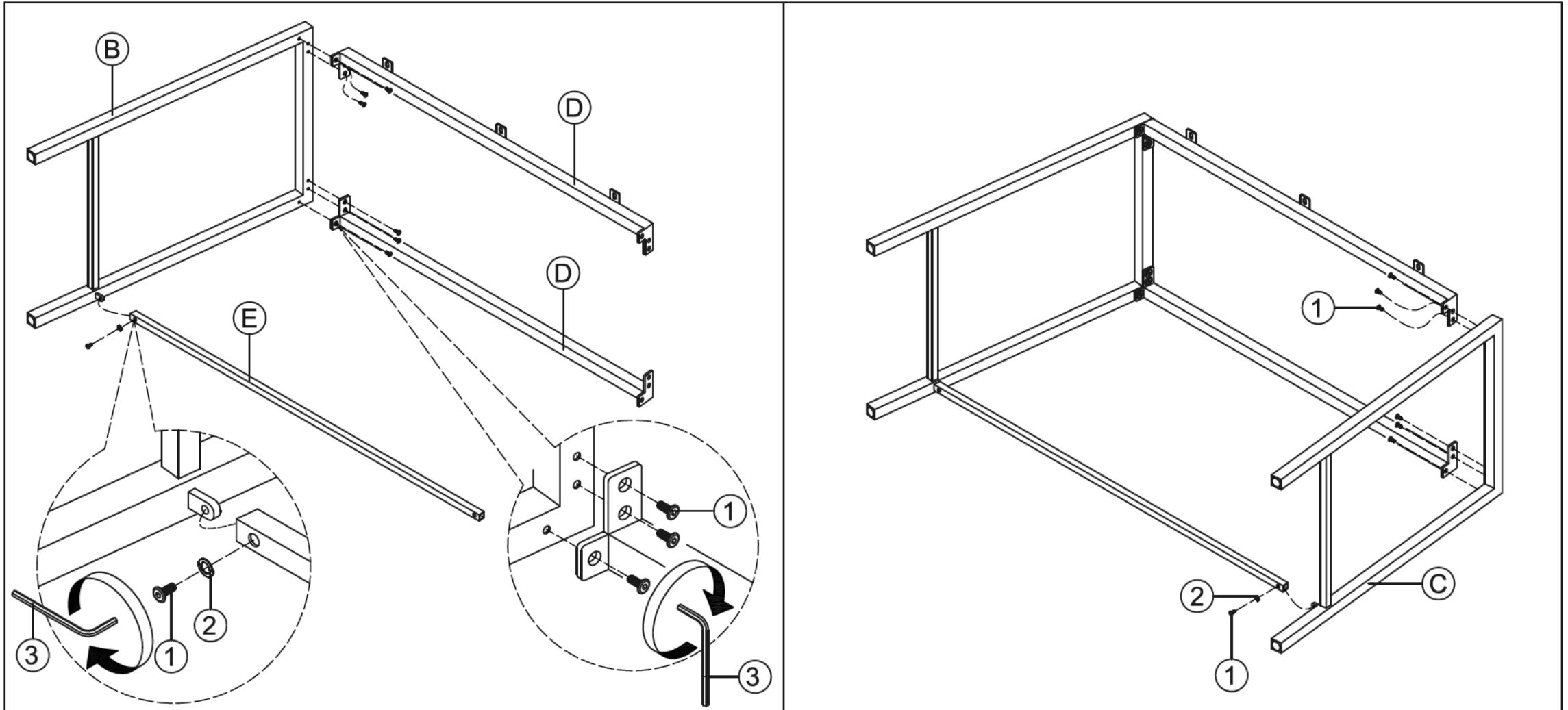

STEP 1 ATTACH TOP FRAMES TO LEFT LEG FRAME USING 15 MM BOLTS. TIGHTEN THE BOLTS USING ALLEN KEY. ATTACH STRETCHER TO LEFT LEG FRAME USING 15 MM BOLT AND SPRING WASHER. TIGHTEN THE BOLT USING ALLEN KEY.

STEP 2 ATTACH RIGHT LEG FRAME TO UNIT USING 15 MM BOLTS AND SPRING WASHER. TIGHTEN THE BOLTS USING ALLEN KEY.

PREPARATION

Before beginning assembly of product, make sure all parts are present. Compare parts with package contents list and hardware contents list.

If any part is missing or damaged, do not attempt to assemble the product.

Estimated Assembly Time: 60 minutes.

Tools Required for Assembly : Phillips Screwdriver

