



Leaders in Reception Seating

Lesro Industries, Inc.
1 Griffin Road South
Bloomfield, CT
06002

Phone 860.243.3226
Fax 860.243.5392
www.lesro.com

Assembly Instructions For Mystic Lounge Guest

Tools required: 9/16" ratchet, Allen Wrench (included in hardware pack)

Important: The assembly process requires that some hardware be kept loose until later in the sequence. Follow these instructions closely to ensure correct assembly.

Recommendation: Retighten all bolts on a seasonal basis to ensure your product remains strong and stable for many years of use.

Weight Capacity: All guest chairs in this series have a weight capacity of 350 lbs. per seat, unless otherwise stated.

Parts List

Arm Frames, left & right
Seat Cushion
Back Cushion

Hardware Pack

3" Hex Bolts, 6 pcs.
Washers, 6 pcs.
Keyhole Posts, 4 pcs.
Allen Wrench

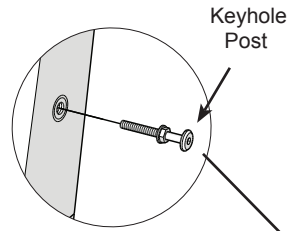

Figure 1

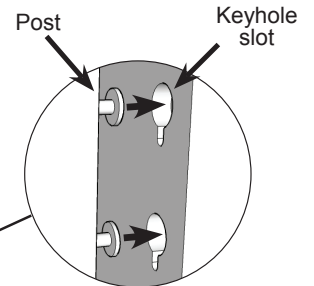

Figure 2

1. Unpack and identify all parts.
2. The arms attach to the back cushion using a post & keyhole system as shown in figure 2.
3. Screw keyhole posts into threaded inserts in back cushion as shown in figure 1. Tighten securely using Allen wrench.
4. Attach back cushion to arm frame by inserting posts into keyhole slots, as shown in figure 3. With posts fully inserted, press back cushion down until posts "bottom-out" in slots.
5. **Important:** Thick fabrics can make it difficult to fully insert posts into the keyhole slots. If this occurs, press the back and arm pieces tightly together to compress the fabric and foam. This will enable the post heads to drop fully into the slots.
6. Attach 2nd arm to back cushion by repeating step 4.
7. When properly connected, bottom edge of back cushion should align with bottom edges of arm frames, as shown in figure 4.
8. Lay assembly on its back on a soft, clean surface and slide seat cushion into place, as shown in figure 5.
9. Attach seat cushion to back cushion and arm frames using 3" hex bolts and washers, as shown in figure 6. Keep all bolts slightly loose for now.
10. With all bolts connected but still loose, stand chair upright on a level surface. Align bottom edges of arm frames, back cushion and seat cushion (figure 4) and tighten all bolts securely.
11. Your chair is now assembled and ready to use.

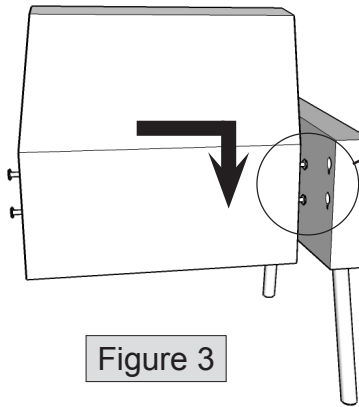

Figure 3

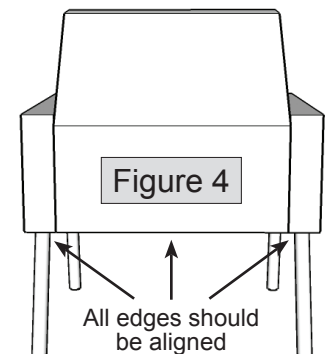

Figure 4

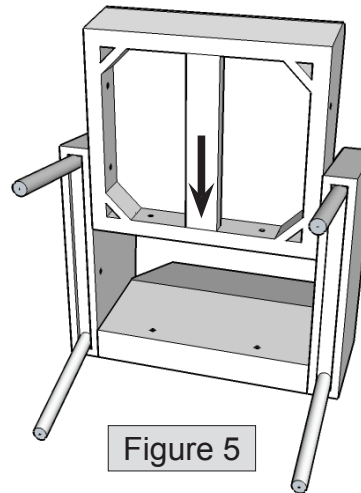

Figure 5

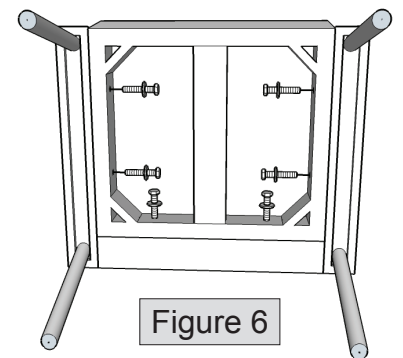

Figure 6

**Thank you for purchasing a Lesro product.
Need assistance with assembly? Call Lesro customer service 1-800-275-7545.**

Visit us online at www.lesro.com