





Read this instruction carefully. See hardware and furniture part list for guidance. Be sure all parts are complete, before you assemble. Place all wooden furniture parts on a clean and flat soft surface to prevent from being scratched. Follow the figure to start assembling.

CAUTIONS : 1. Do not FULLY - TIGHTEN the nut or nut bolt until all nut or bolt is ready assembled.
 2. Do not OVER - TIGHTEN the nut or bolt to avoid causing damages to the thread.
 3. Keep all hardware parts out of reach of children.

NOTE : THE LIST AND QUANTITY SHOWN ARE FOR 1 UNIT ASSEMBLY.
 Tool needed : Screwdriver & Hammer (not provided).

PART LIST		
ITEM	DESCRIPTION	QTY
A	CHAIR	1 PC
B	LEG (L)	1 PC
C	LEG (R)	1 PC
D	SUPPORT RAIL (LONG)	1 PC
E	SUPPORT RAIL (SHORT)	1 PC

HARDWARE LIST		
ITEM	DESCRIPTION	QTY
1	JCBC Bolt M6 x 50mm 	4 PCS
2	WOOD SCREW M4 x 38mm 	4 PCS
3	WOOD DOWEL M10 x 40mm 	8 PCS
4	M4 ALLEN KEY (BALL SHAPE) 	1 PC

STEP 1

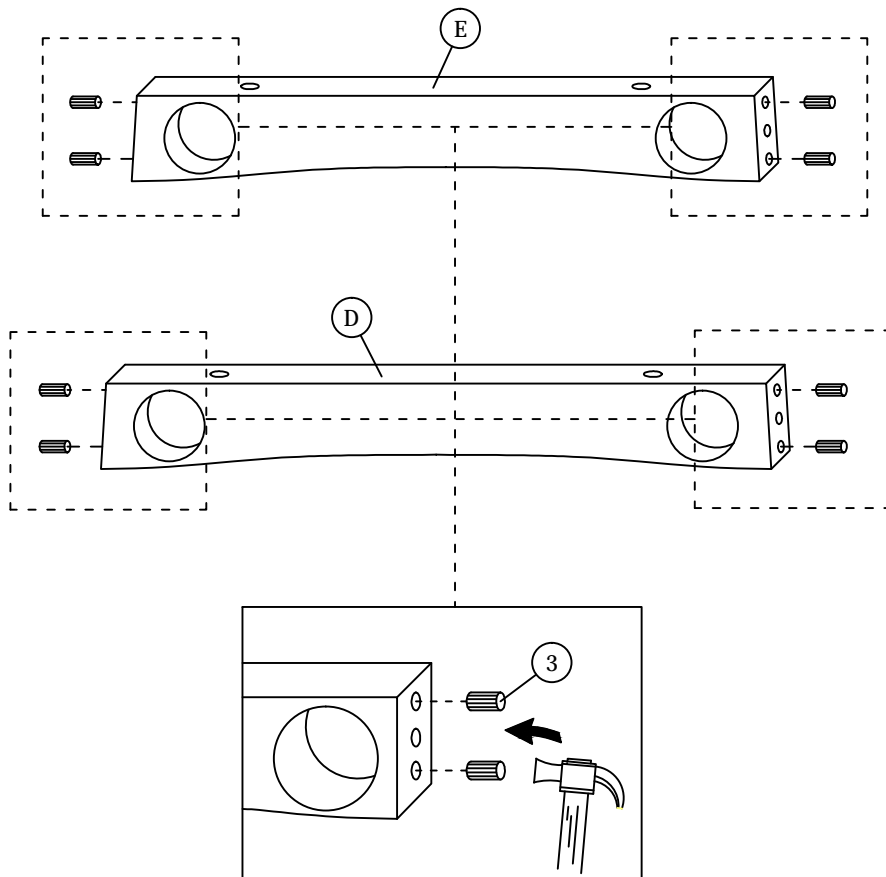

STEP 2

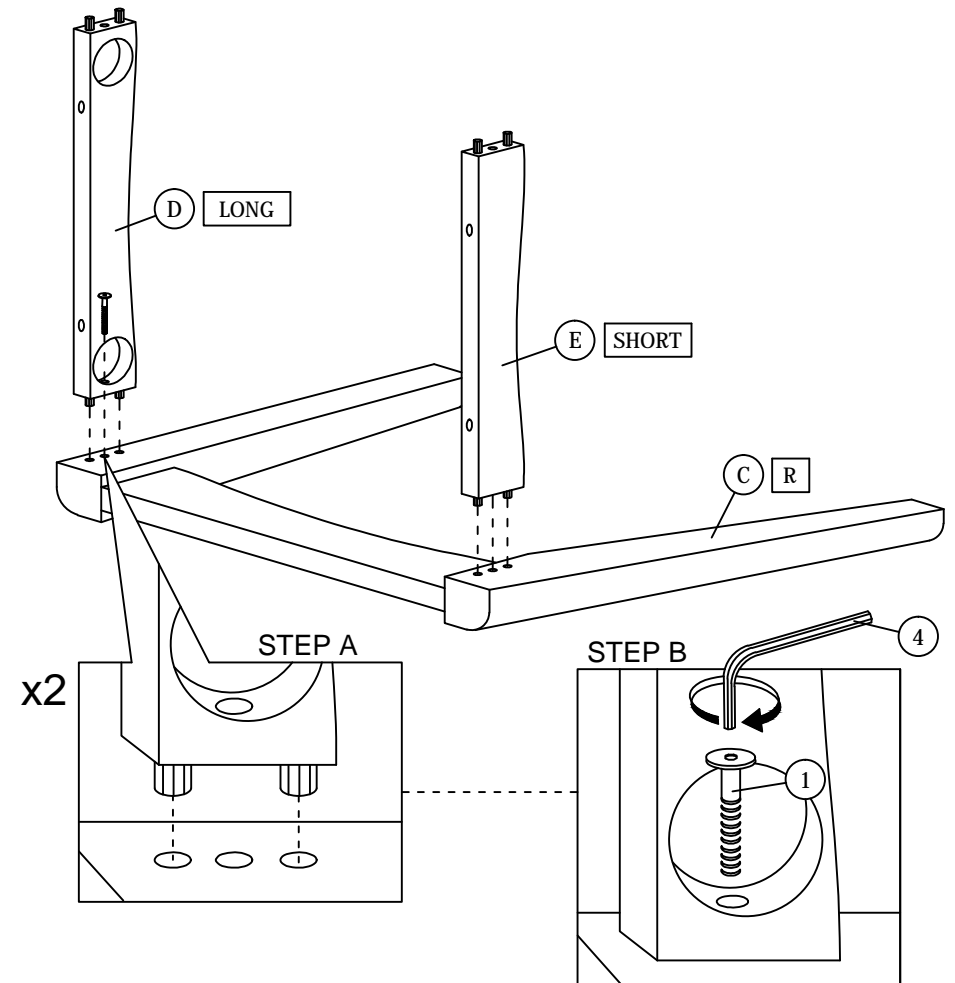

STEP 3

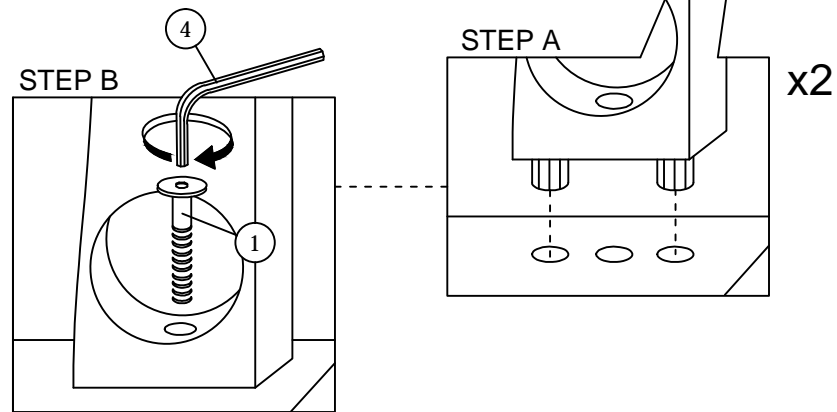
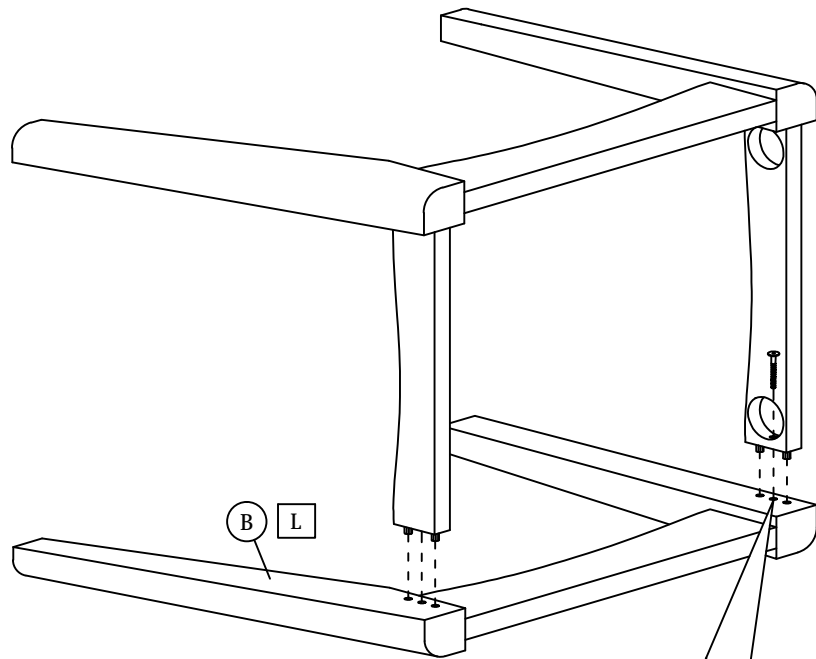

STEP 4

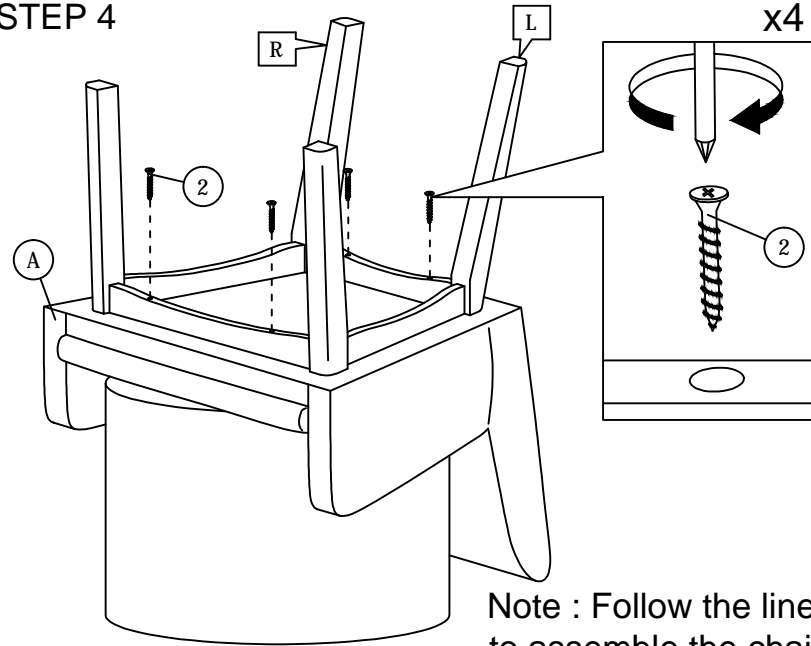

STEP 5

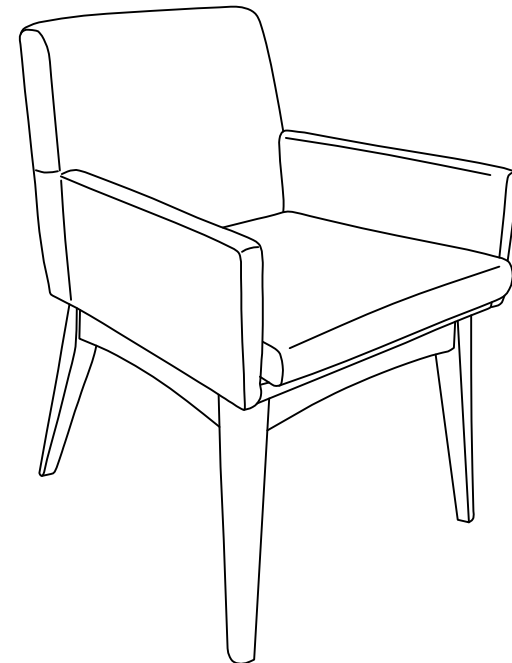

ASSEMBLY INSTRUCTIONS

Read this instruction carefully. See hardware and furniture part list for guidance. Be sure all parts are complete, before you assemble. Place all wooden furniture parts on a clean and flat soft surface to prevent from being scratched. Follow the figure to start assembling.

CAUTIONS : 1. Do not FULLY - TIGHTEN the nut or nut bolt until all nut or bolt is ready assembled.
2. Do not OVER - TIGHTEN the nut or bolt to avoid causing damages to the thread.
3. Keep all hardware parts out of reach of children.

NOTE : THE LIST AND QUANTITY SHOWN ARE FOR 1 UNIT ASSEMBLY.

PART LIST		
ITEM	DESCRIPTION	QTY
A	TABLE TOP	1 PC
B	LEGS	4 PCS

PART LIST		
ITEM	DESCRIPTION	QTY
1	JCBC BOLT M6 x 60mm 	8 PCS
2	M6 FLAT WASHER 	8 PCS
3	M6 SPRING WASHER 	8 PCS
4	M4 ALLEN KEY 	1 PC

STEP 1

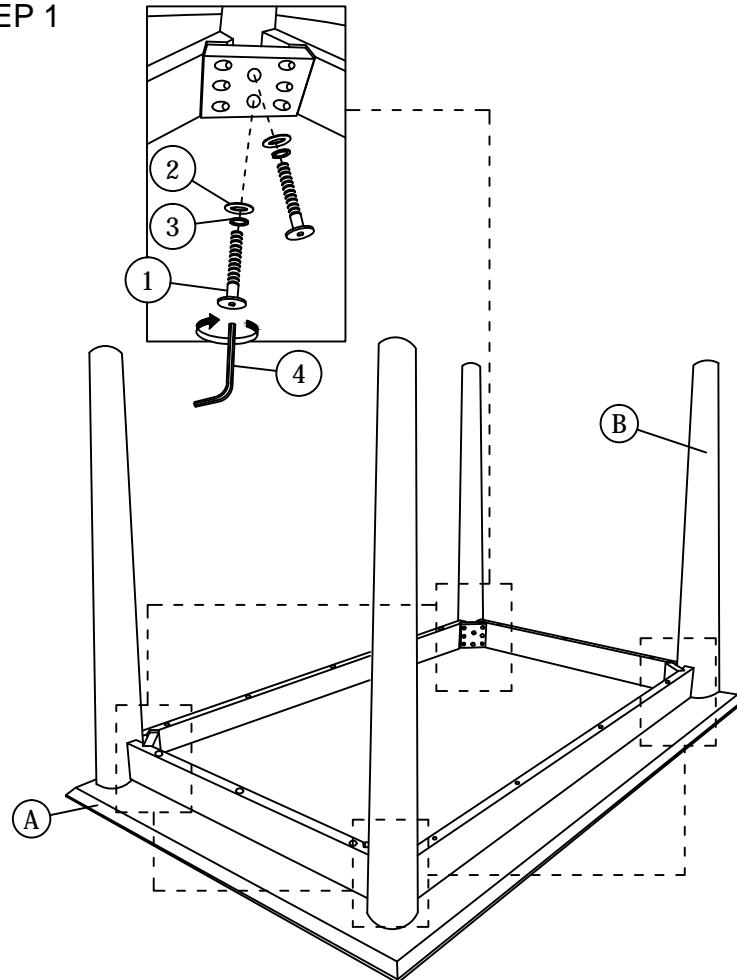

STEP 2

