

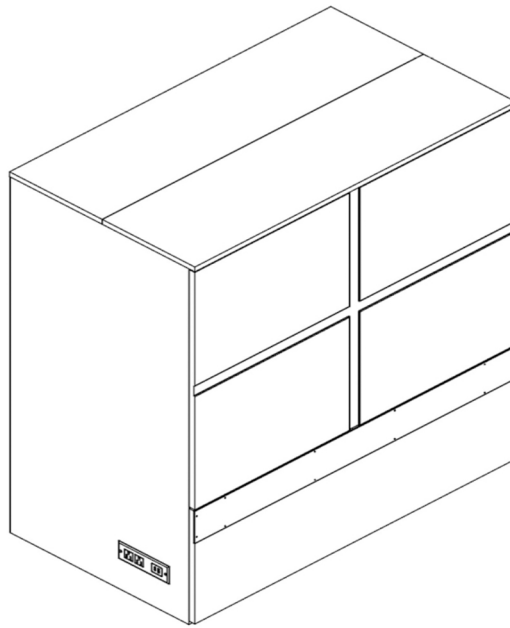

## VING TWIN BED WITH STORAGE HEADBOARD

ASSEMBLY INSTRUCTION FOR MODELS

XP000460307



Thank you for purchasing from VINGLI!

Please contact us via email if parts are missing or damaged, we will gladly ship your replacement parts free of charge. Please attach your Order ID so that we can assist you better.

✉ EMAIL

🌐 WEBSITE

⚠ IMPORTANT

[support@vingli.com](mailto:support@vingli.com)

[www.vingli.com](http://www.vingli.com)

THIS INSTRUCTION BOOKLET  
CONTAINS IMPORTANT SAFETY  
INFORMATION. PLEASE READ  
AND KEEP FOR FUTURE  
REFERENCE.

# RETURN & WARRANTY

## Thank you for choosing our product!

We would like to take this opportunity to thank you for choosing VINGLI.

We hope that you are completely satisfied with your purchase, and enjoy it for years to come.

The logo for VINGLI, featuring the word "VINGLI" in a bold, sans-serif font with a curved line underneath it.



support@vingli.com

**Your satisfaction is our highest pursuit.**

## Return Policy

VINGLI believes you will absolutely love your wood bed, but if for some reason you want to return the product, please contact us directly before you decide to return your product to the retailer. Our Customer Service organization can answer most concerns and can assist you with any questions you may have about your new product. Please contact us first by emailing support@vingli.com or by submitting a request at <https://www.vingli.com>

The item must be returned in good condition, in original box, with all original proof of purchase, parts and accessories, within the time frame specified by the retailer it was purchased from.

## Warranty

VINGLI warrants this product to be free from defects in material and workmanship agrees to remedy any such defect. This warranty covers one year from the date of original purchase. This is solely limited to be repair or replacement of defective parts and no assembly labor is included.

This warranty does not apply to any product which has been improperly assembled, subjected to misuse or abuse or which has been altered or repaired in anyway.

Components repaired or replaced warranted through the remainder of the original warranty period only. The defective components will be repaired or replaced without charge, subject to the terms and conditions described above.

For help with assembly, identifying parts, product information or to order parts, please contact us via support@vingli.com.

# BEFORE STARTING

## Before Using Product



- Read each step carefully before starting. It is very important that each step is performed in the correct order. If these steps are not followed in sequence, assembly difficulties will occur.



- Make sure all parts are included. Most board parts are labeled or stamped on the raw edge.

- Have the following tools.



- Recommended # of people needed for assembly: 2 (however it is always better to have an extra hand). Estimated assembly time is 2.5hours.



- Work in a spacious area and near where the unit will be used, preferably on a carpet, or use a piece of the cardboard packaging to protect your floor and product.



- For a smooth assembly process, we suggest you keep a lite tightness for all the screws during assembly. After the whole product is assembled, firmly tighten all the screws.

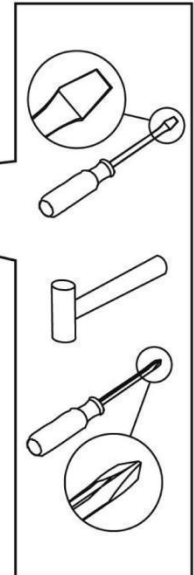

## WARNING:

- Do not allow children to climb on unit
- Serious or fatal crushing injuries can occur from furniture tip-over. To prevent this furniture from tipping over, it must be permanently fixed to the wall. Fixing devices for the wall are not included since different wall materials require different types of fixing devices. Use fixing devices suitable for the walls in your home. For advice on suitable fixing systems, contact your local specialized dealer.
- Avoid sharp objects or corrosive chemicals to prevent damage to the product
- During assembly, keep parts and packaging materials away from children and pets as there could be potential injury and choking hazards.

# TIPS

## How To Separate A Ball Bearing Slider

(1) Pull toward arrow to open the slider until it's stops and then flip it over

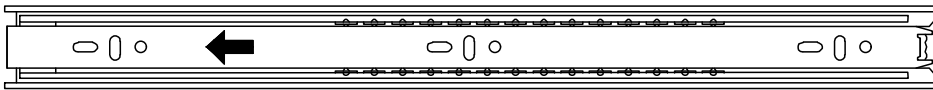

(2) Push plastic lever down and pull apart the slider at the same time

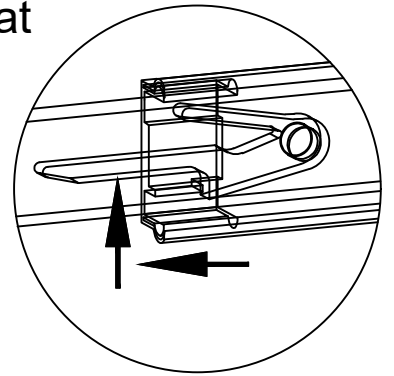
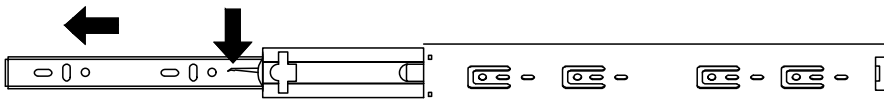

(3) After disassembly



OUTER TRACK K-2

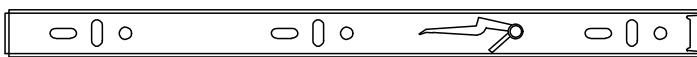

INNER TRACK K-1

## How to Assemble the Slider

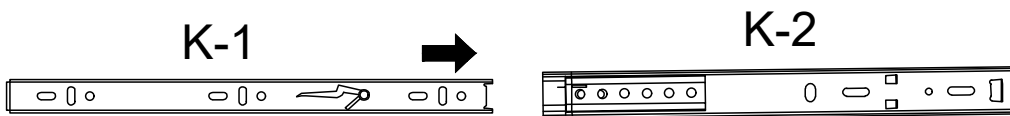



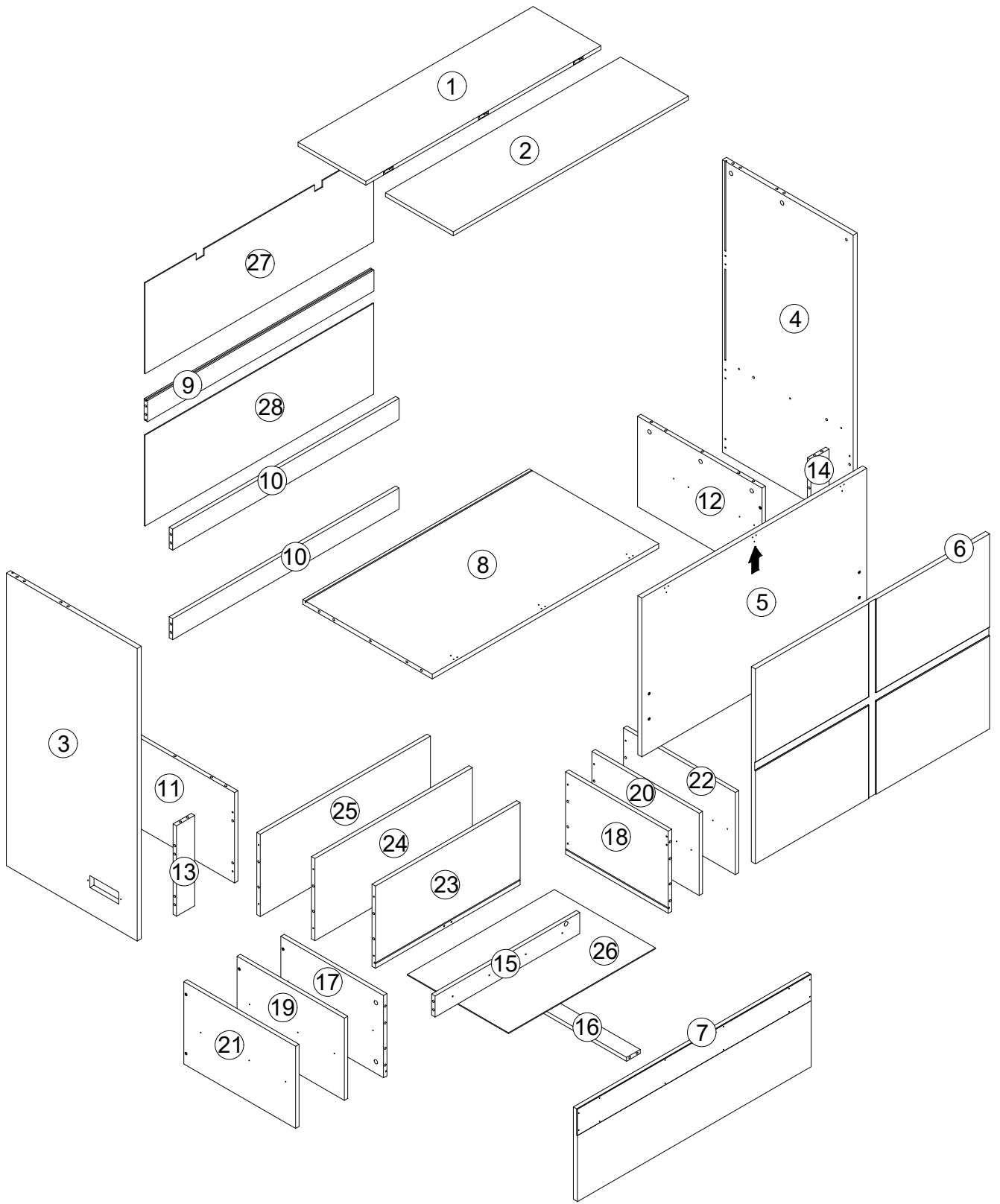



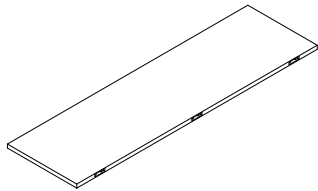
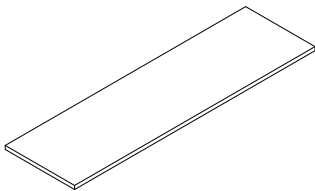
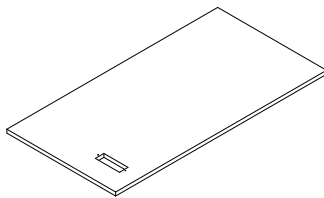
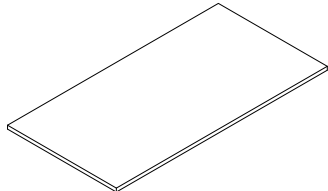
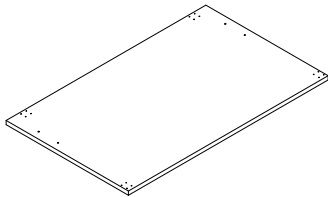
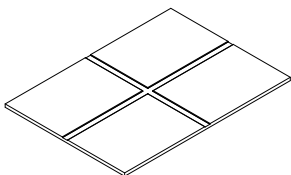
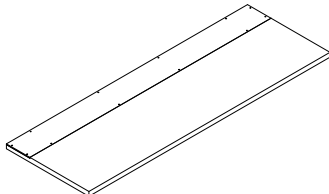
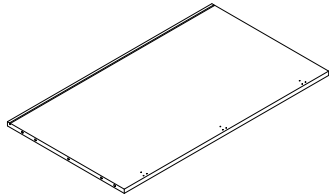
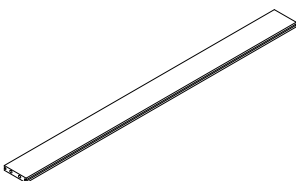
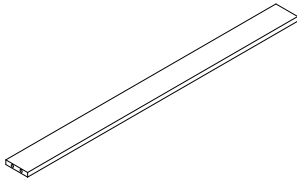
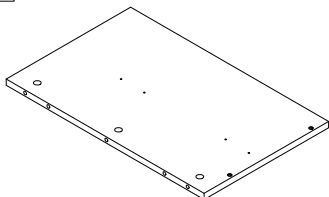
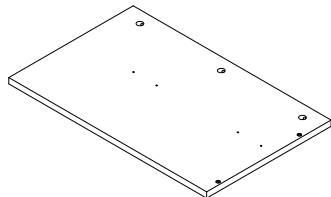
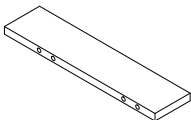
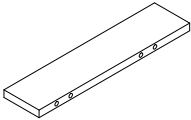
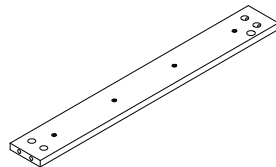
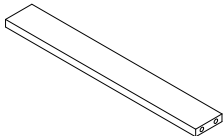
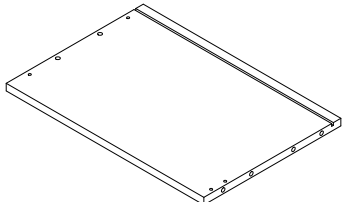
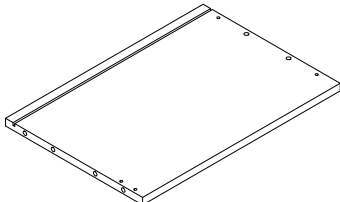
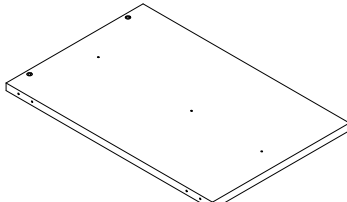
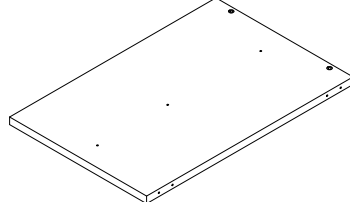
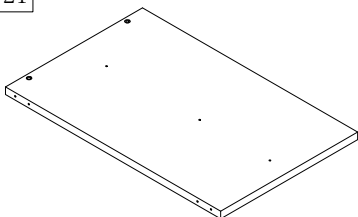
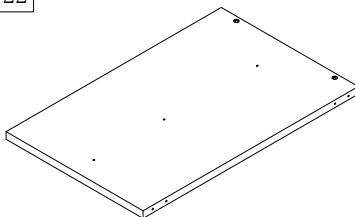
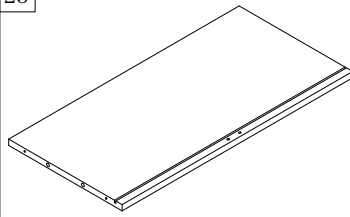
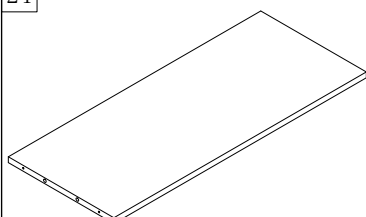
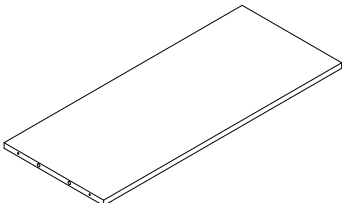
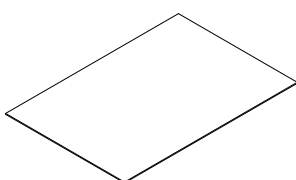
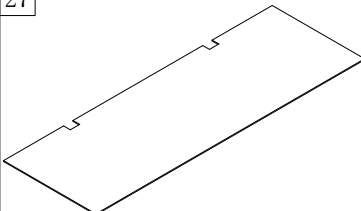
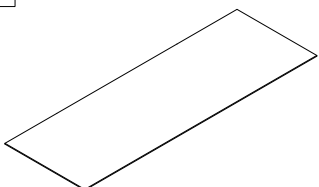



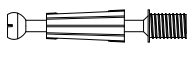

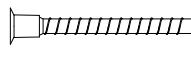

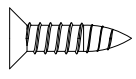

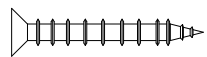
Align the outer track(K-2) with the center of the inner track(K-1) and push in.

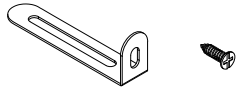

# PART LIST

1		2		3		4	
	1030x297x15 1PC		1030x297x15 1PC		1110x573x18 1PC		1110x573x18 1PC
5		6		7		8	
	985x603x15 1PC		1026x740x18 1PC		1026x351x18 1PC		992x567x18 1PC
9		10		11		12	
	992x80x15 1PC		992x80x15 2PCS		545.5x343x15 1PC		545.5x343x15 1PC
13		14		15		16	
	343x80x15 1PC		343x80x15 1PC		634x80x15 1PC		433x60x15 1PC
17		18		19		20	
	450x312x15 1PC		450x312x15 1PC		470x312x15 1PC		470x312x15 1PC
21		22		23		24	
	490x312x15 1PC		490x312x15 1PC		690x312x15 1PC		746x312x15 1PC
25		26		27		28	
	746x312x15 1PC		644x443x3 1PC		1002x344.5x3 1PC		1002x344.5x3 1PC

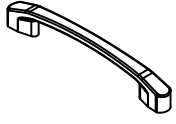

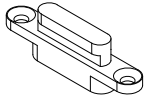
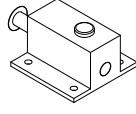
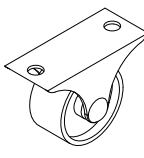
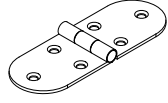
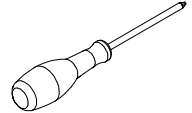
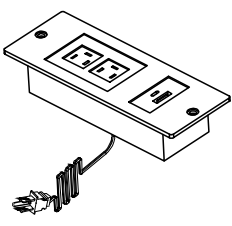
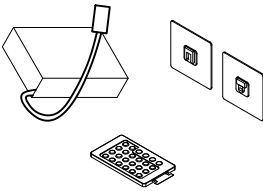
## PART LIST

<p>A-48PCS</p> <div style="text-align: center; margin: 10px 0;">   </div> <p style="text-align: center;"><b>Ø6x40</b></p>	<p>B-48PCS</p> <div style="text-align: center; margin: 10px 0;">  </div> <p style="text-align: center;"><b>Ø15x11</b></p>	<p>C-20PCS</p> <div style="text-align: center; margin: 10px 0;">   </div> <p style="text-align: center;"><b>Ø5x40</b></p>	<p>D-134PCS</p> <div style="text-align: center; margin: 10px 0;">   </div> <p style="text-align: center;"><b>Ø3.5x14</b></p>
<p>E-6PCS</p> <div style="text-align: center; margin: 10px 0;">   </div> <p style="text-align: center;"><b>Ø4x25</b></p>	<p>F-6PCS</p> <div style="text-align: center; margin: 10px 0;">   </div> <p style="text-align: center;"><b>M4x22</b></p>	<p>G-38PCS</p> <div style="text-align: center; margin: 10px 0;">  </div> <p style="text-align: center;"><b>Ø8x40</b></p>	<p>H-10PCS</p> <div style="text-align: center; margin: 10px 0;">   </div>
<p>I-2PCS</p> <div style="display: flex; justify-content: space-around; align-items: center; margin: 10px 0;"> <div style="text-align: center;">  <p>I-1</p> </div> <div style="text-align: center;">  <p>I-2</p> </div> </div>	<p>J-2PCS</p> <div style="text-align: center; margin: 10px 0;">  </div>	<p>K-6PCS</p> <div style="text-align: center; margin: 10px 0;">  </div>	
<p>L-3PCS</p> <div style="text-align: center; margin: 10px 0;">  </div>	<p>M-4PCS</p> <div style="text-align: center; margin: 10px 0;">  </div>	<p>N-12PCS</p> <div style="text-align: center; margin: 10px 0;">  </div>	<p>O-6PCS</p> <div style="text-align: center; margin: 10px 0;">  </div>
<p>P-1PCS</p> <div style="text-align: center; margin: 10px 0;">  </div>	<p>Q-1PC</p> <div style="text-align: center; margin: 10px 0;">  </div>	<p>R-1PCS</p> <div style="text-align: center; margin: 10px 0;">  </div>	

Step: 1

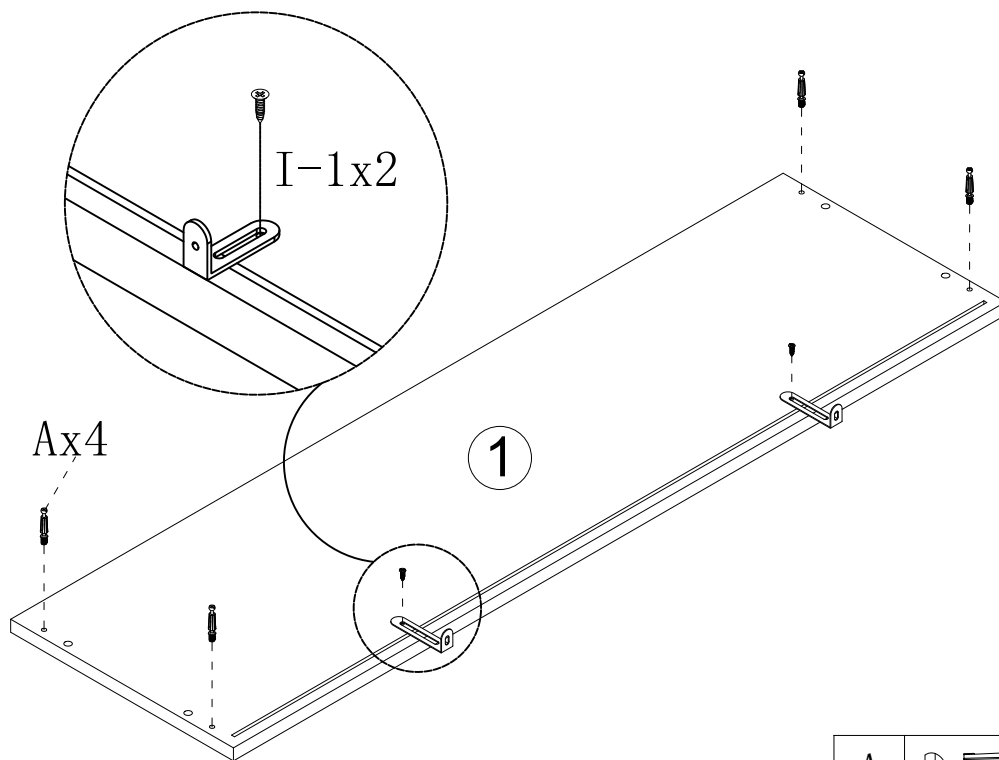
Place screws (A) and L-shaped brackets (I-1) into the holes on plate (1) and tighten with the screwdriver (P).



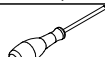

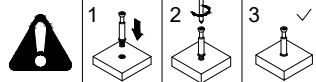
A		Ø6x40	4
I-1			2
P			1

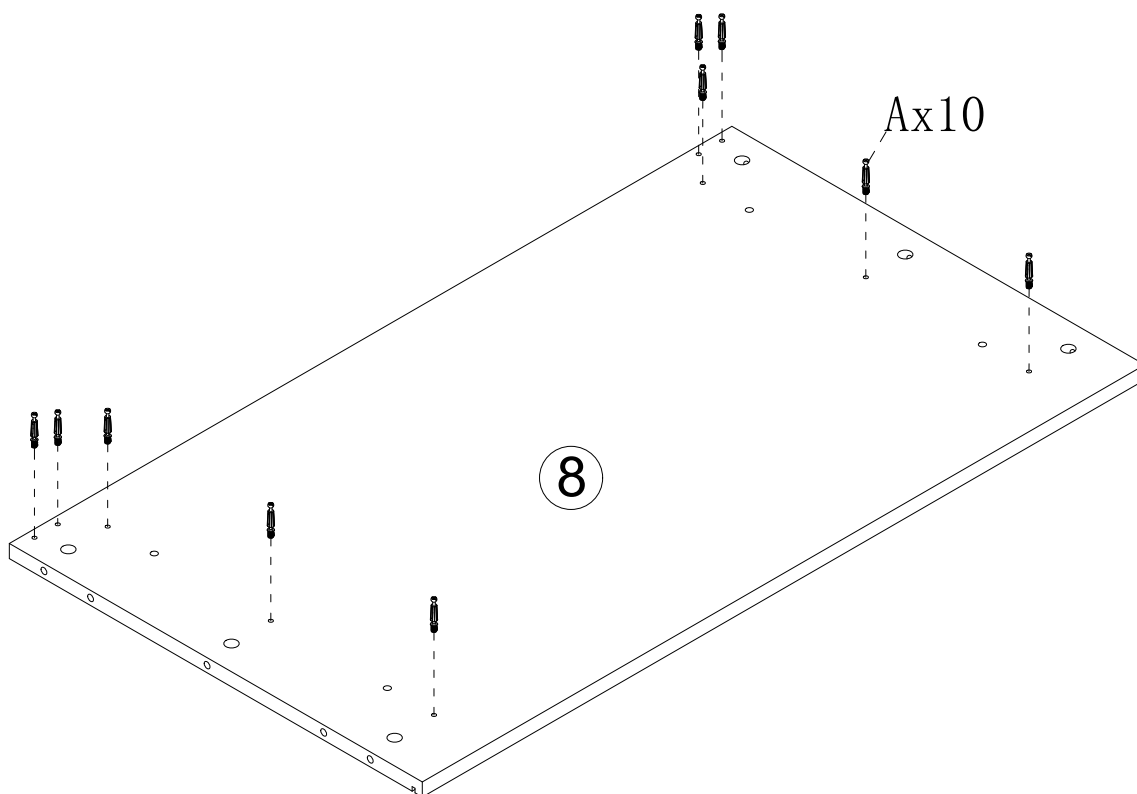

Step: 2

Lock screws (A) into the holes on board (8).



A		Ø6x40	10
---	---	-------	----

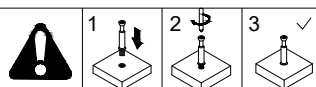

Step: 3

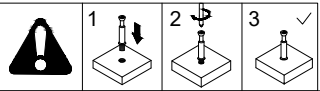
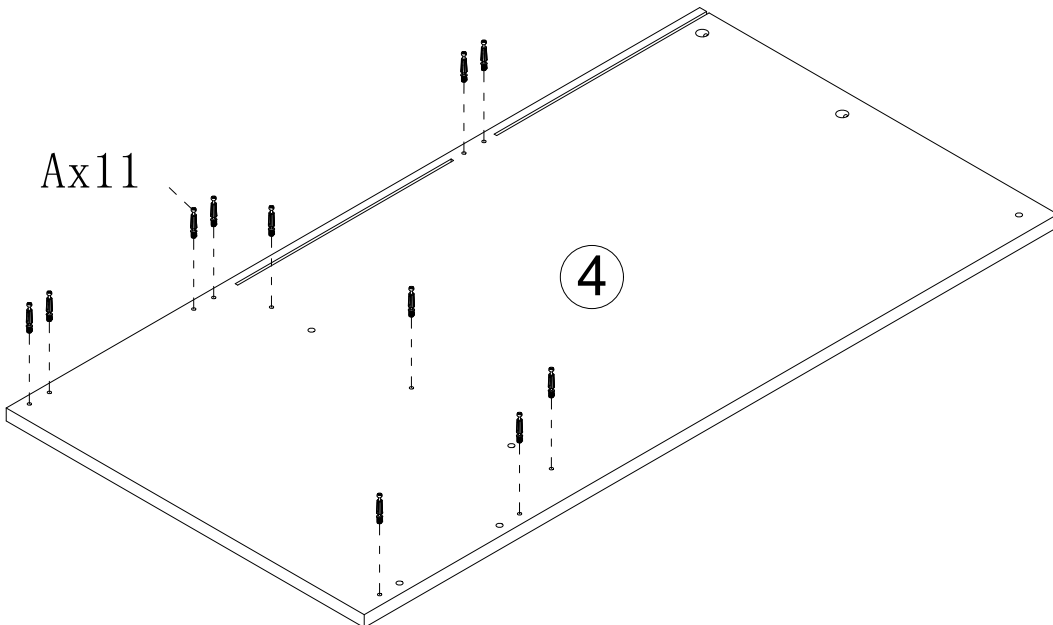
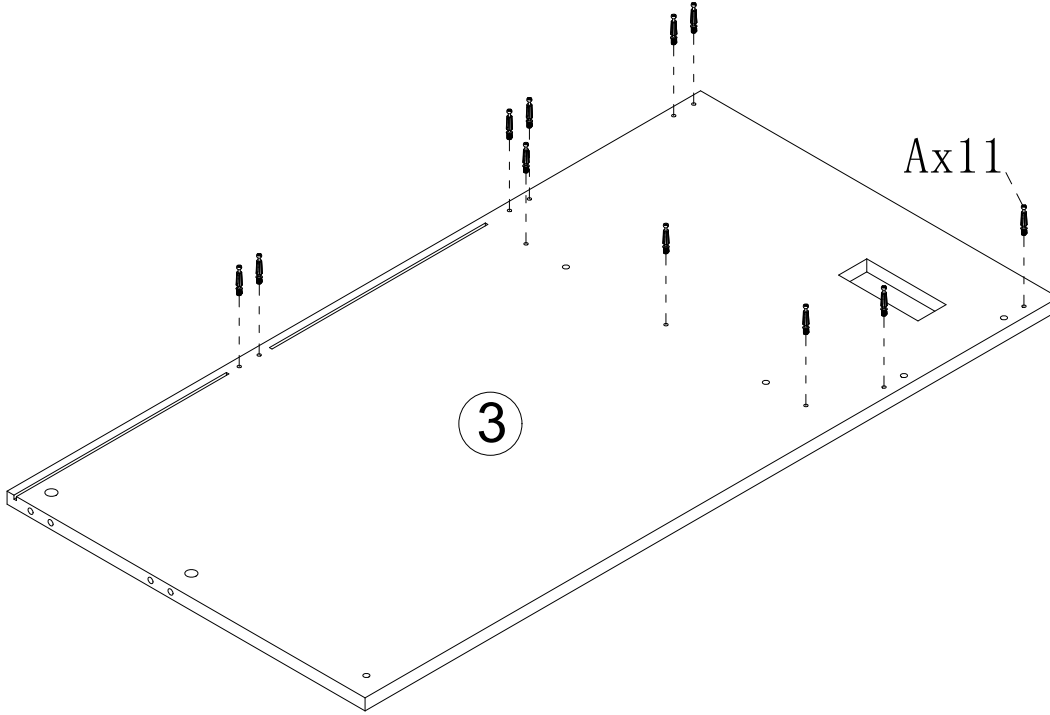

Lock screws (A) into the holes on boards (3, 4).

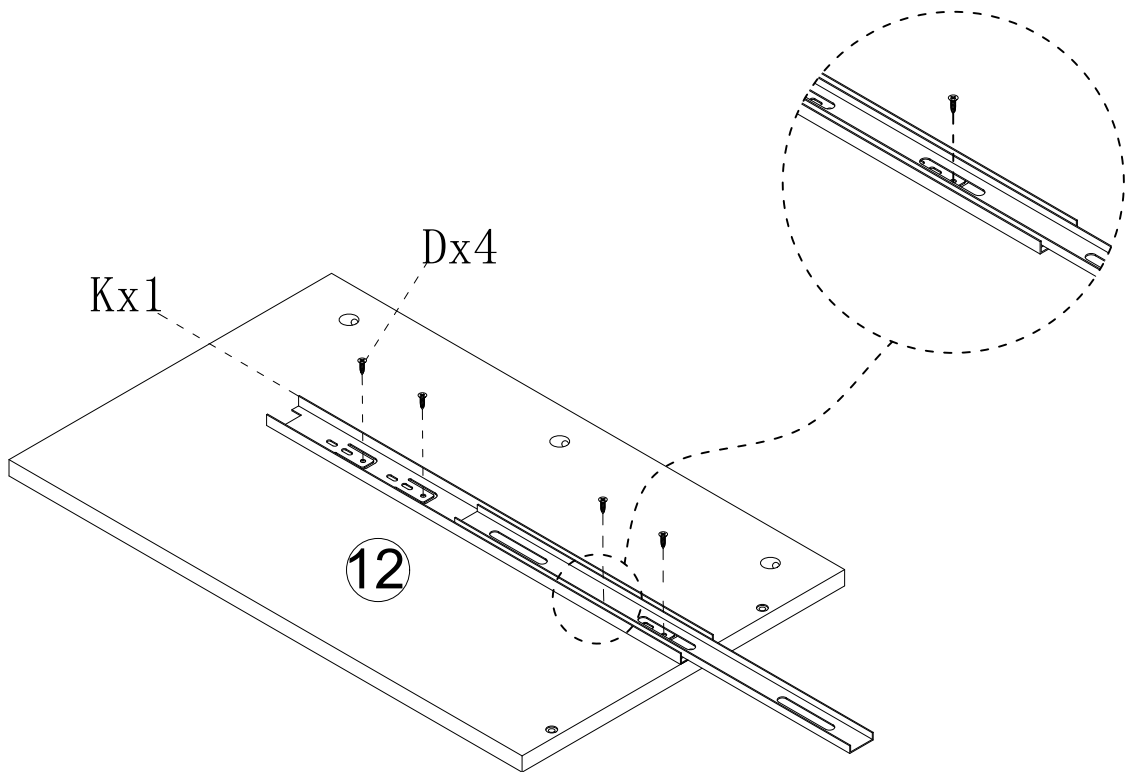
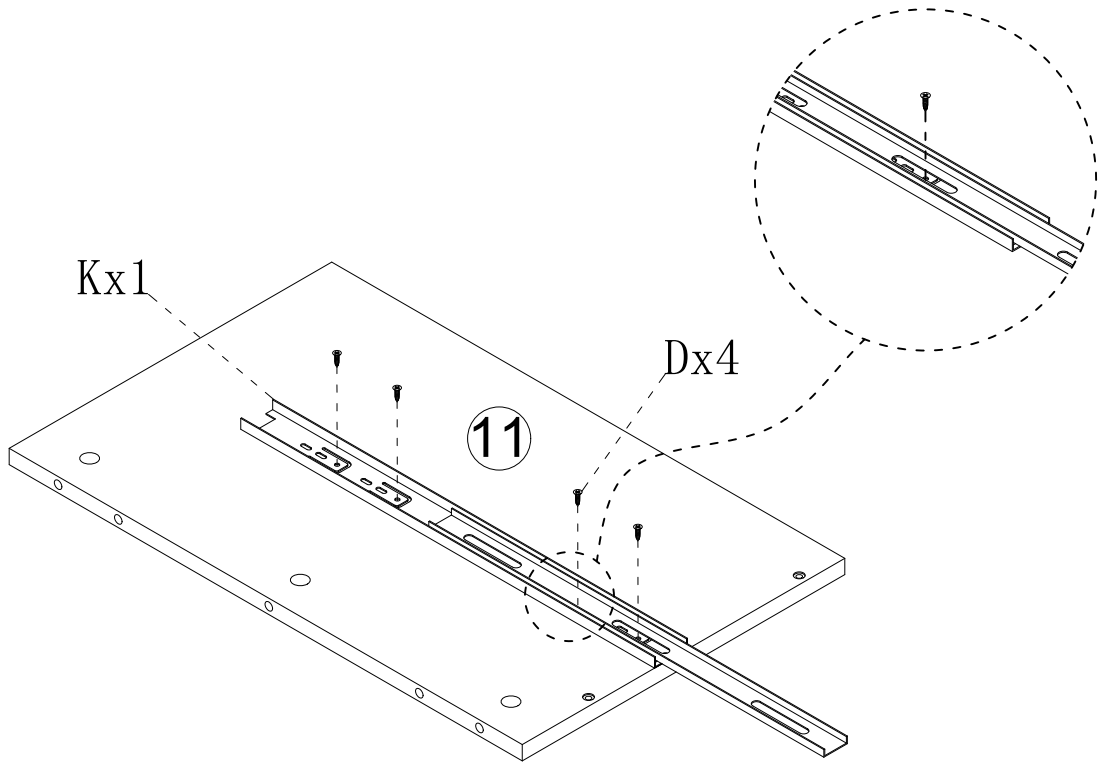

Step: 4

Lock rails (K) and screws (D) into the holes on the boards (11, 12).





D	 Ø3.5x14	8
K		2

Step: 5

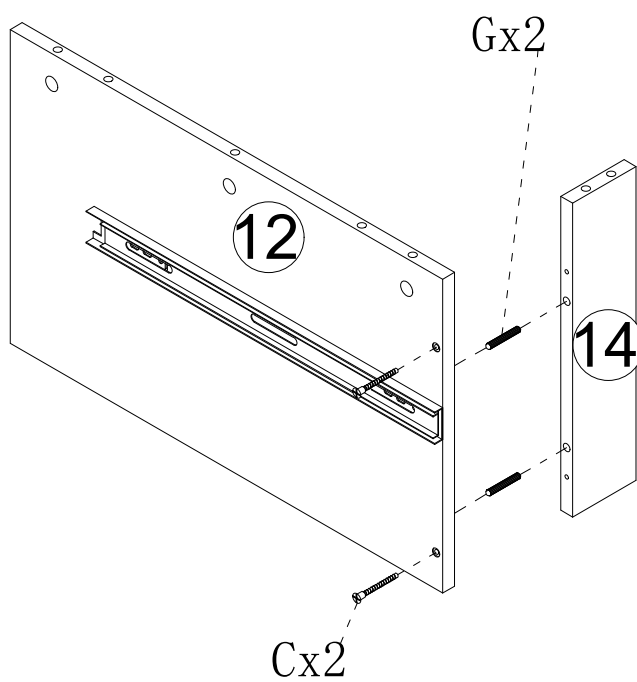
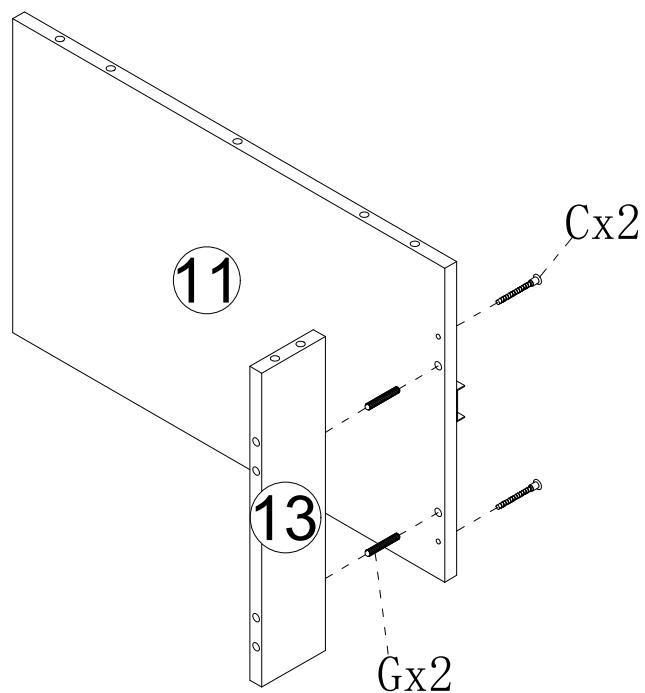
Use screws (C) and wooden dowels (G) to attach the boards (11 and 13, 12 and 14) to the corresponding holes.

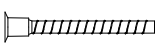



C	 Ø5x40	4
G	 Ø8x40	4

Step: 6

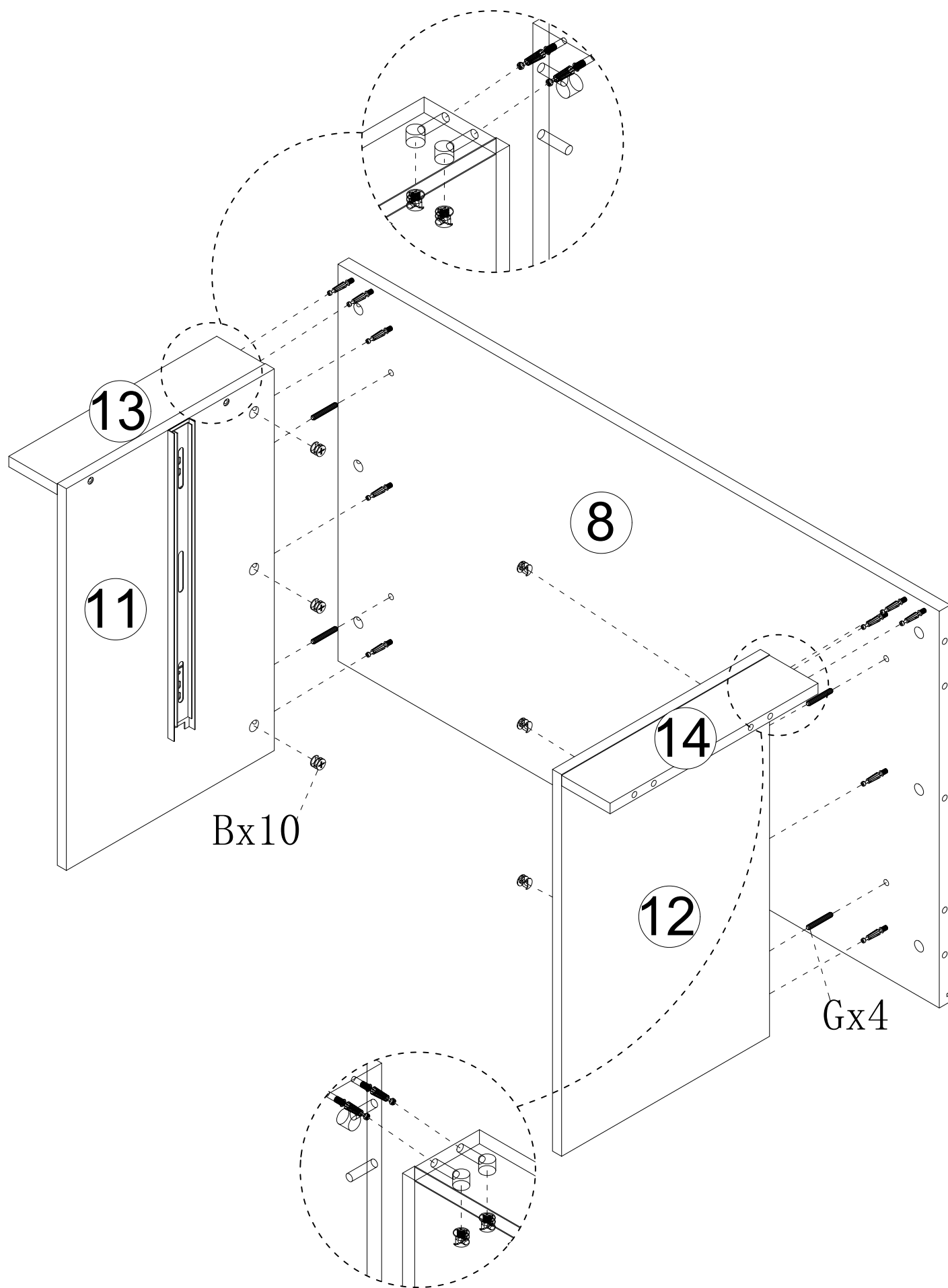
Use wooden dowels (G) and eccentrics (B) to attach boards (13, 11, 14 and 12) to the corresponding holes.





B		Ø15x11	10
G		Ø8x40	4

Step: 7

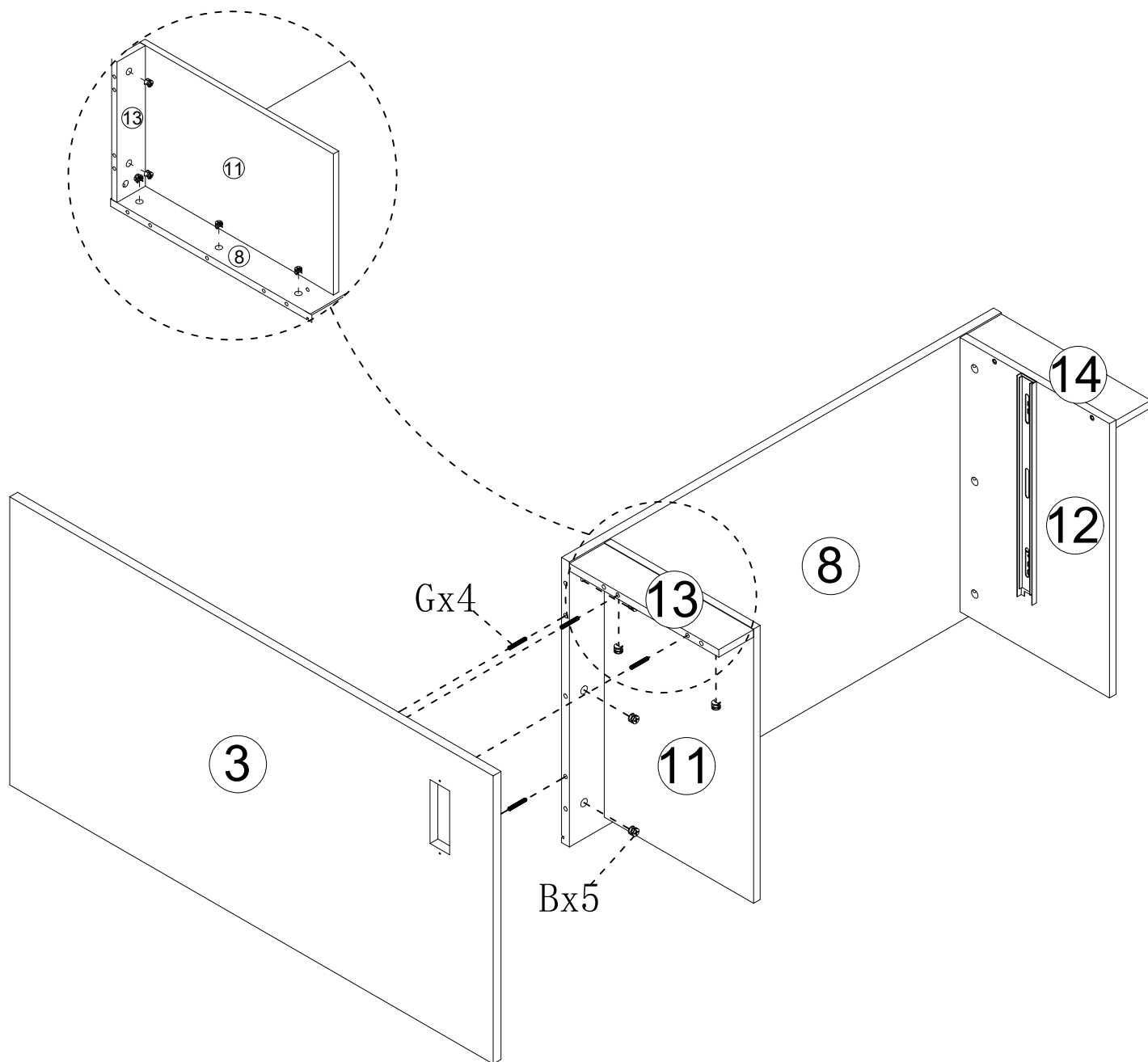
Connect the cabinet assembled in Step 6 to board (3) using eccenters (B) and wooden dowels (G).



B		Ø15x11	5
G		Ø8x40	4

Step: 8

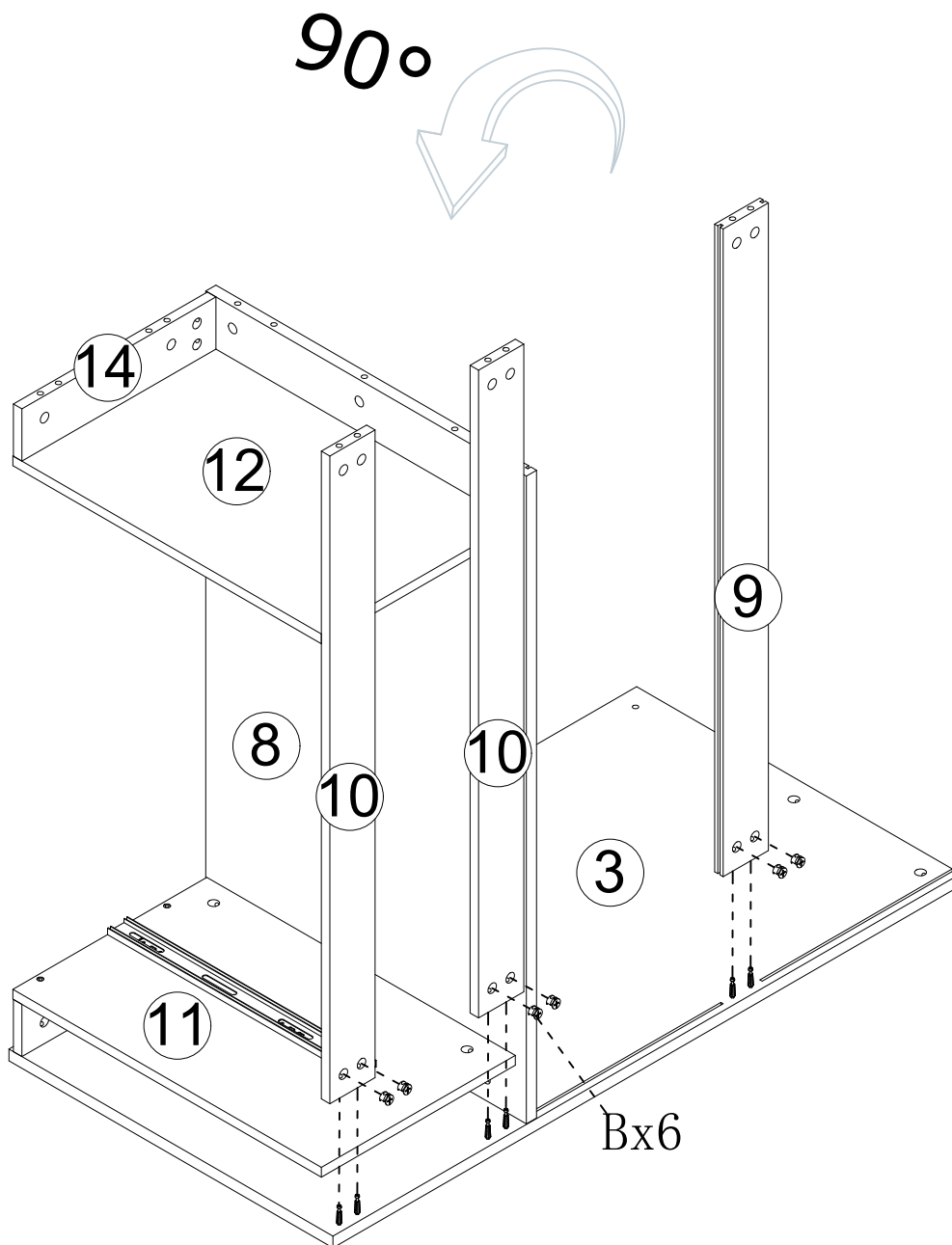

Rotate the assembled No. 7 cabinet unit 90 degrees, then connect panel (10) and panel (9) with cam lock (B).

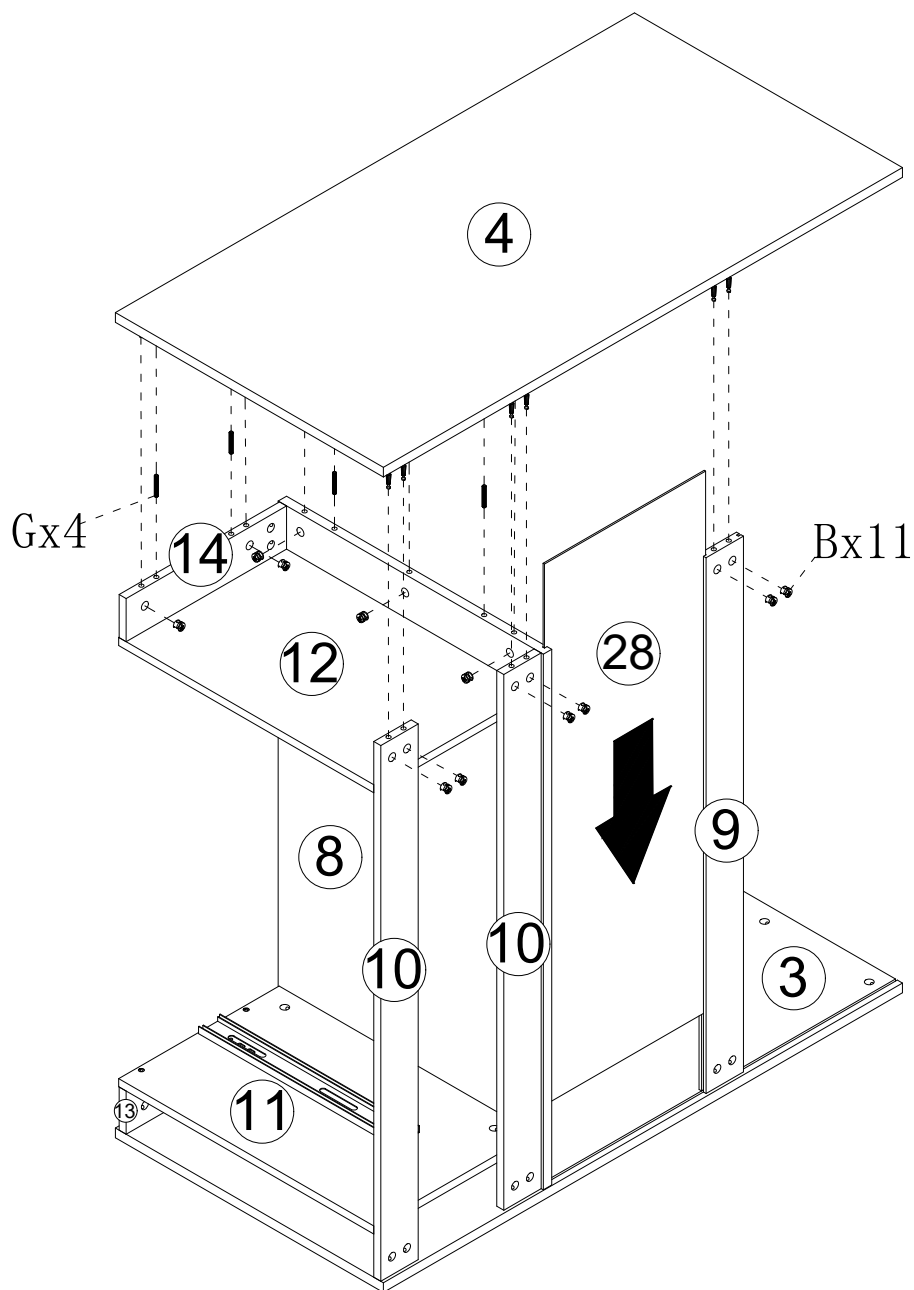

Step: 9

Insert board (28) into the back board slot, and connect board (4) to the cabinet assembled in Step 7 with centers (B) and wooden dowels (G).



B		Ø15x11	11
G		Ø8x40	4

Step: 10

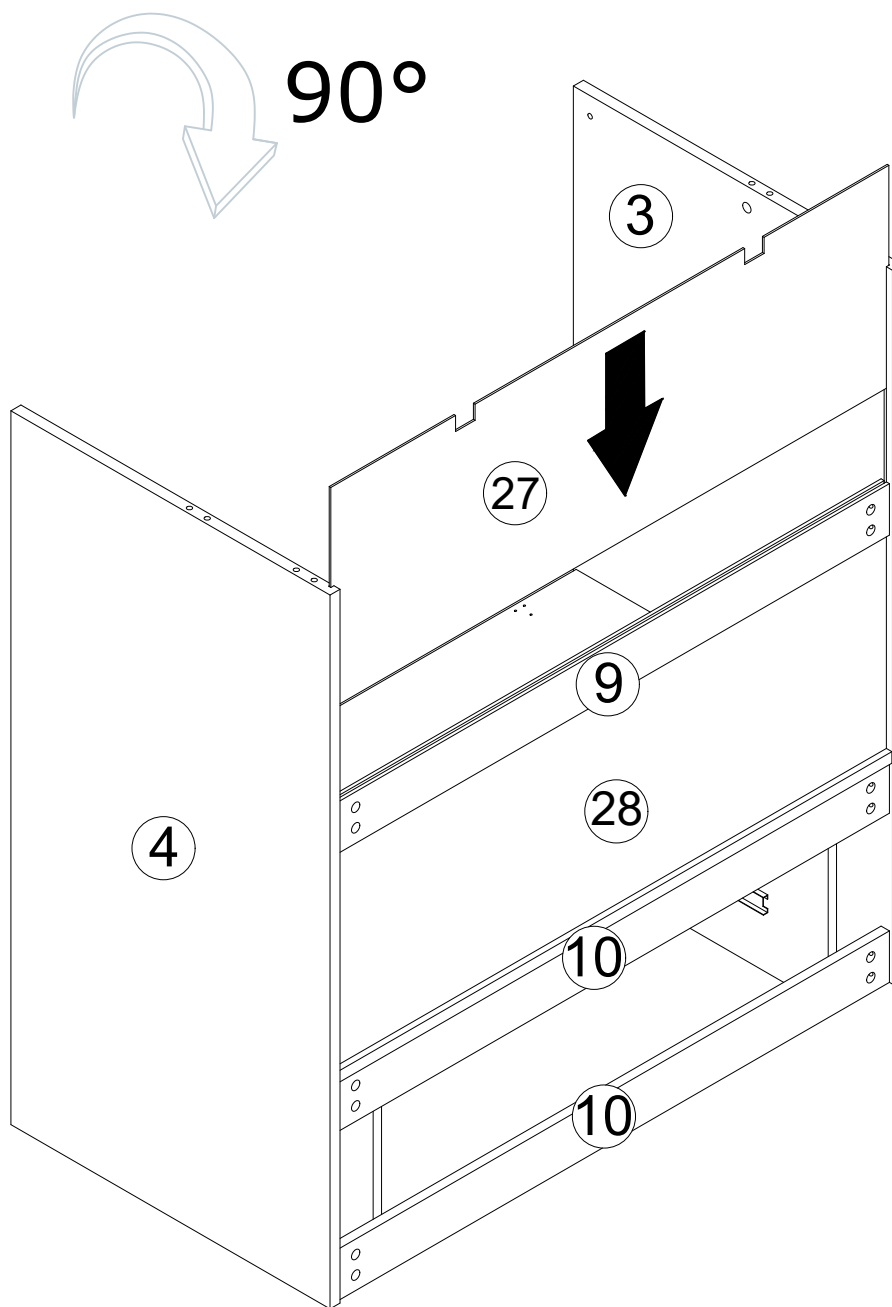

Turn the cabinet assembled in Step 8 90 degrees, and then insert board (27) into the back board slot.

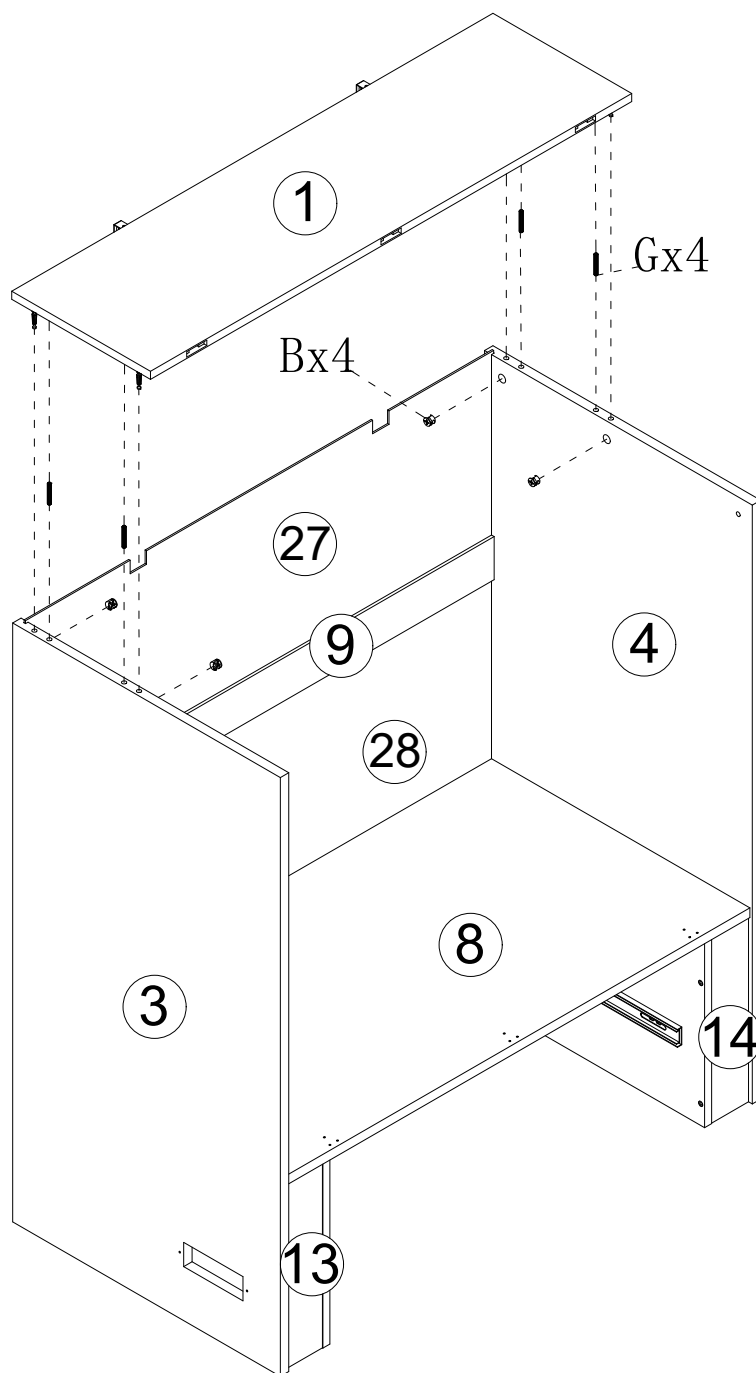

Step: 11

Connect board (1) with eccenters (B) and wooden dowels (G).





B		Ø15x11	4
G		Ø8x40	4

Step: 12

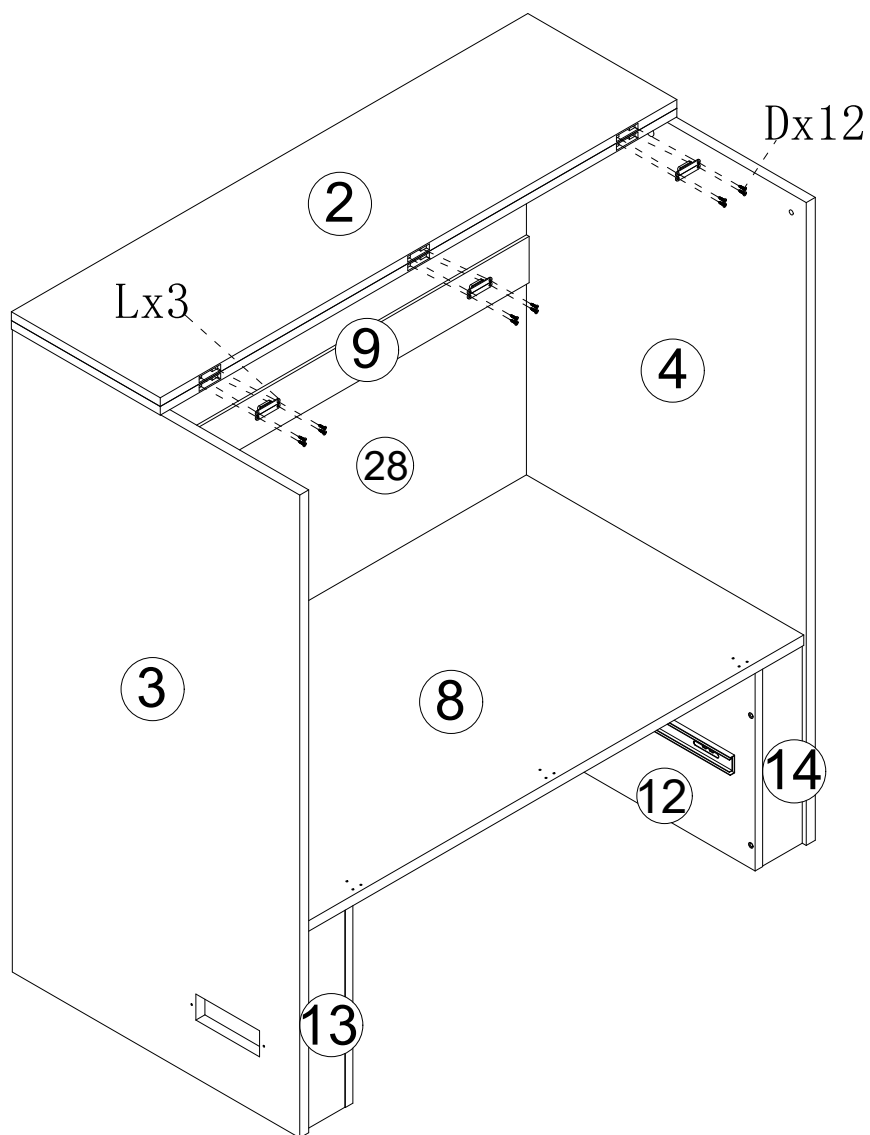
Connect board (2) to board (1) using hinges (L) and screws (D).





D	 Ø3.5x14	12
L		3

Step: 13

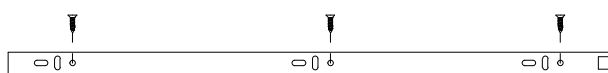
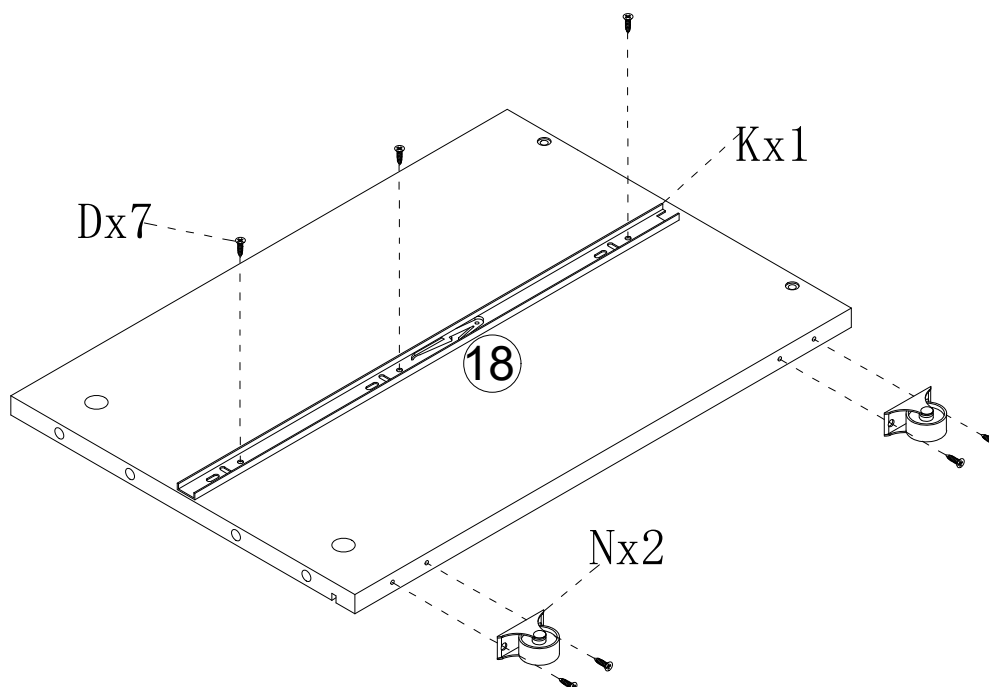
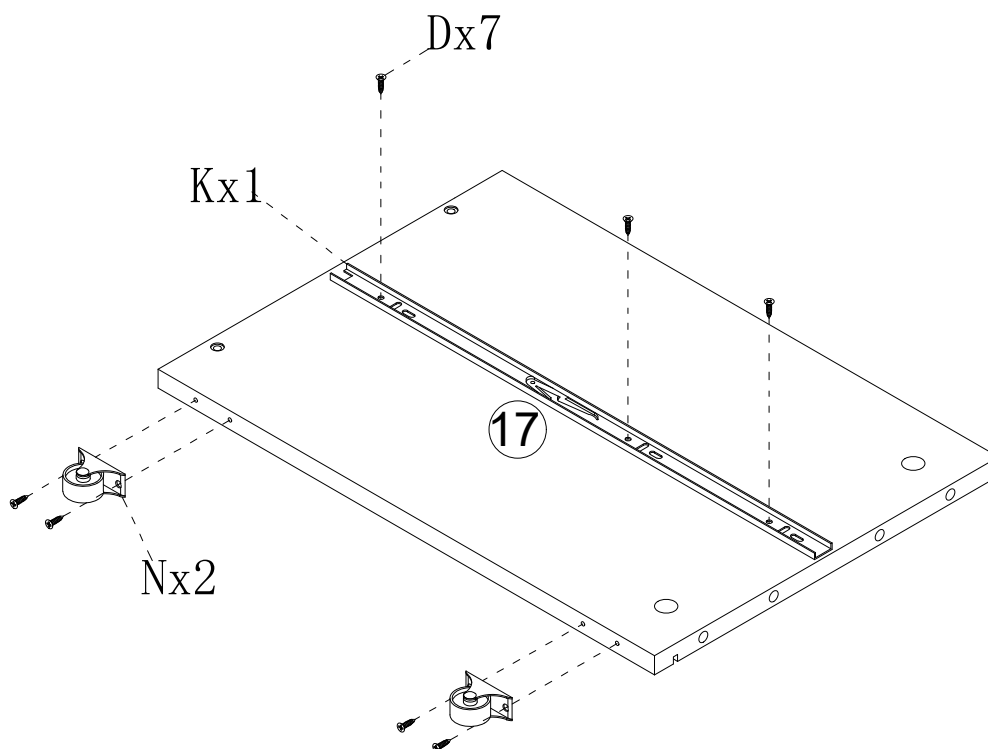
Secure rails (K) and pulleys (N) to boards (17, 18) with screws (D).

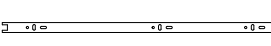

D	 Ø3.5x14	14
K		2
N		4

Step: 14

Lock screws (A) into the corresponding holes on boards (17, 18).

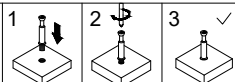
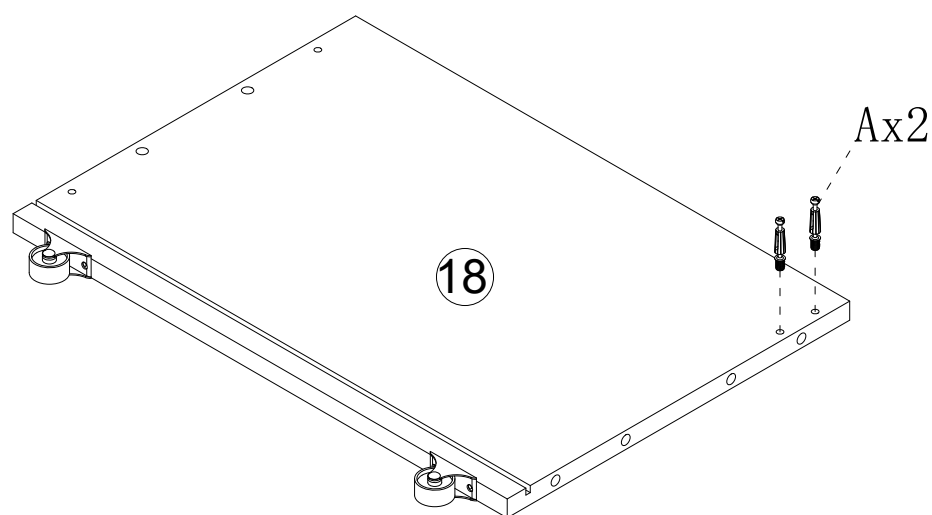
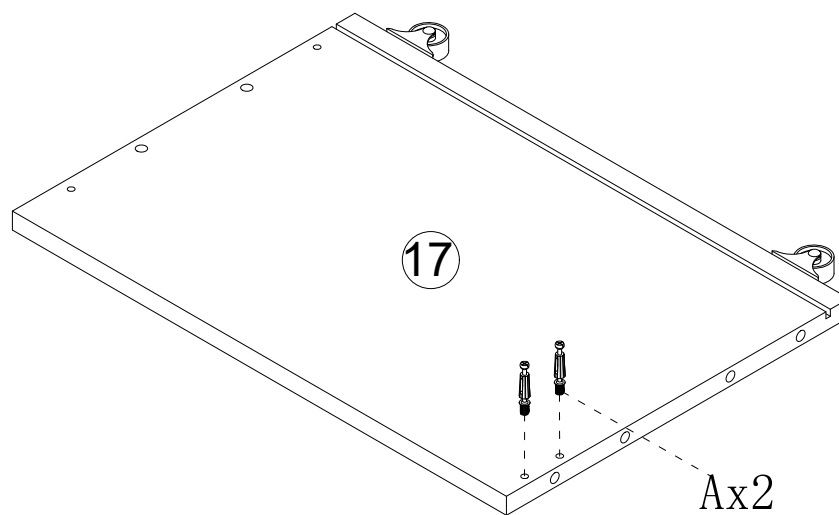

A





4

Step: 15

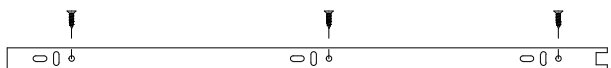
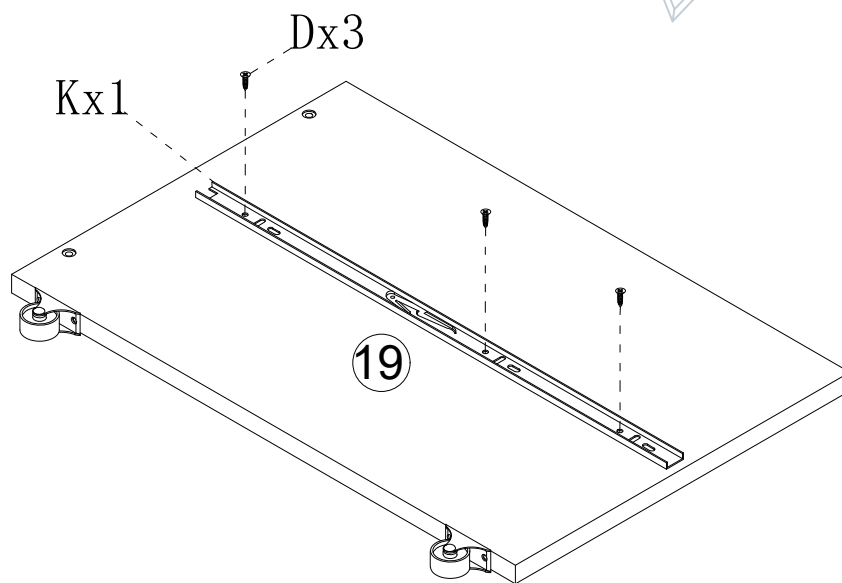
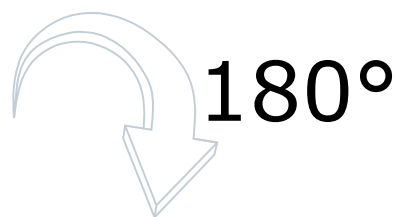
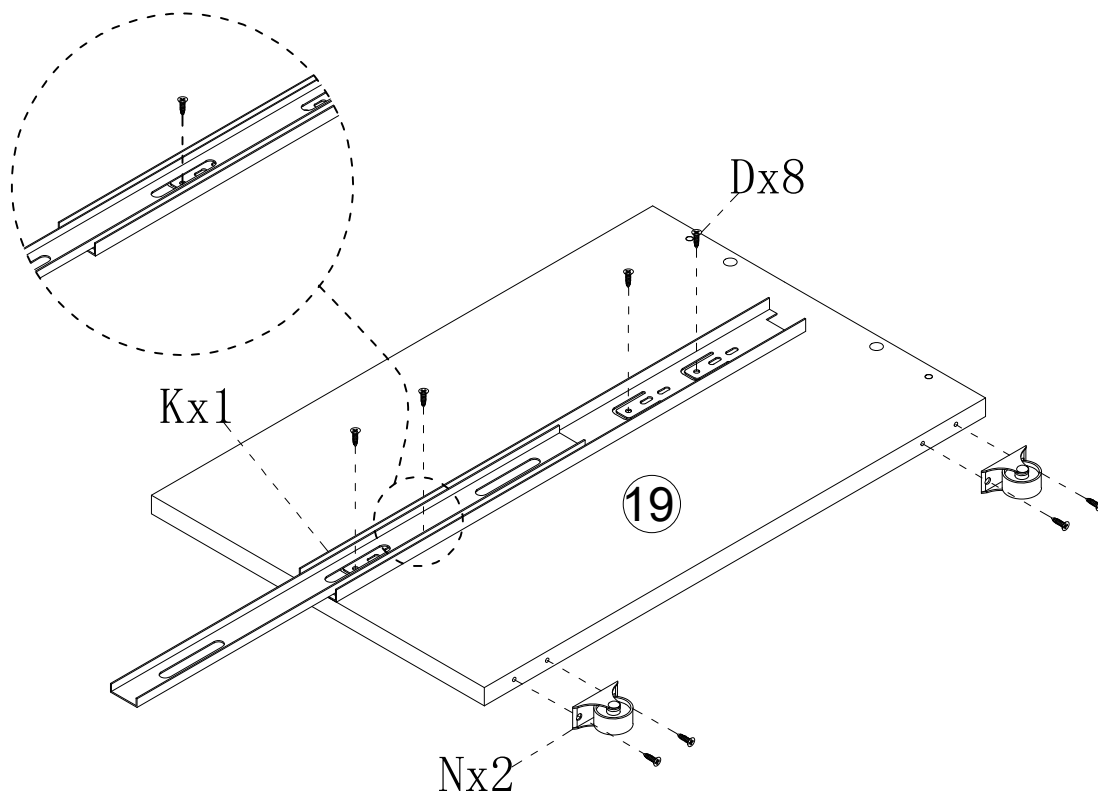
Place rail (K) and pulleys (N) on the holes on board (19) and secure them with screws (D).

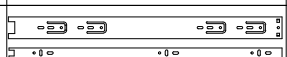



D	 Ø3.5x14	11
K		1
N		2

Step: 16

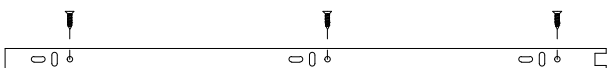
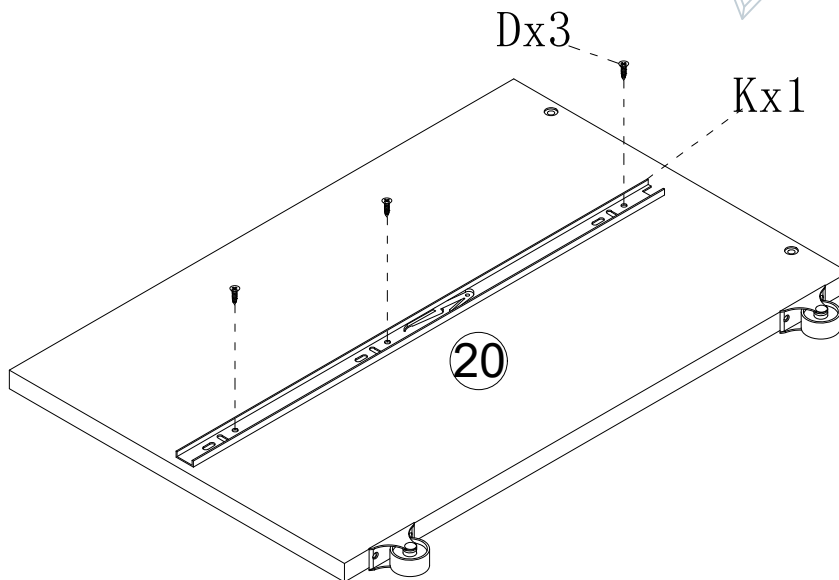
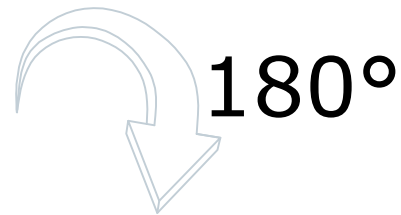
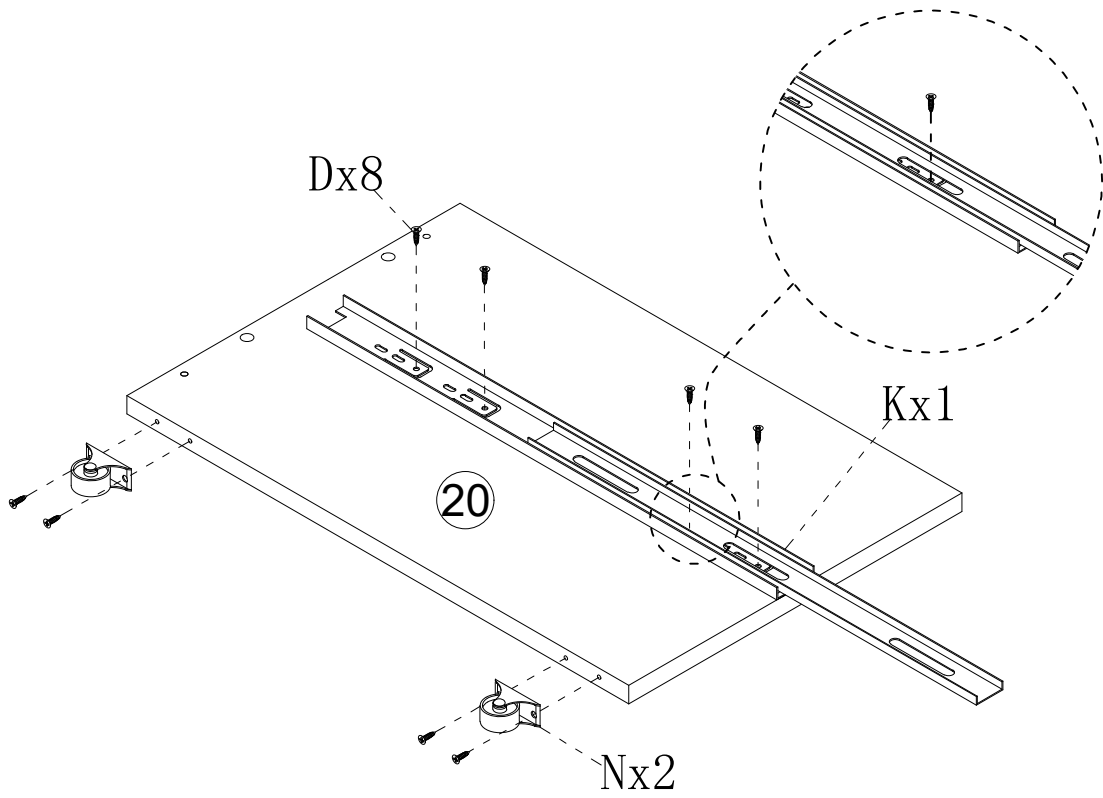
Place rail (K) and pulleys (N) on the holes on board (20) and secure them with screws (D).

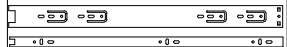



D	 Ø3.5x14	11
K		1
N		2

Step: 17

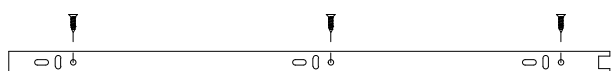
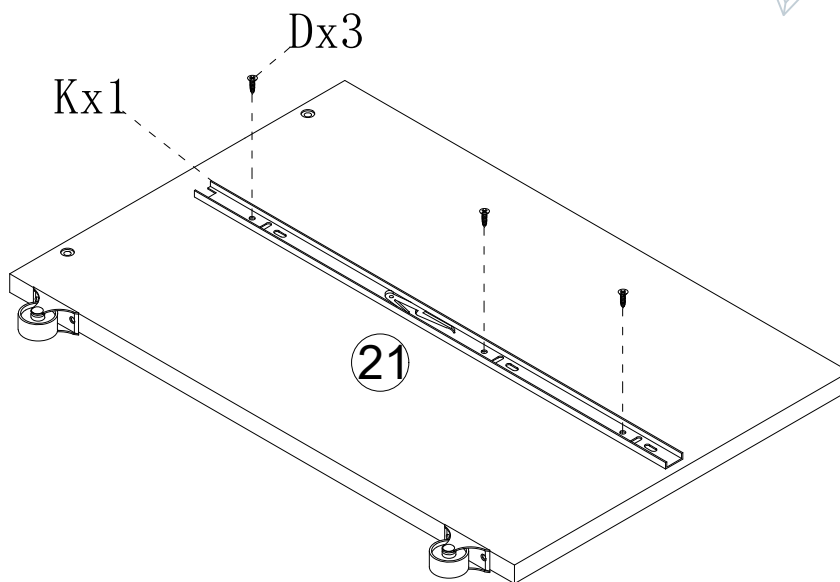
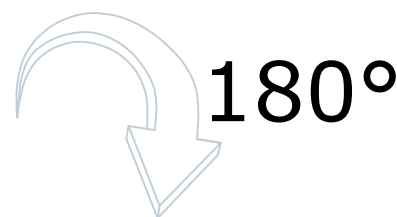
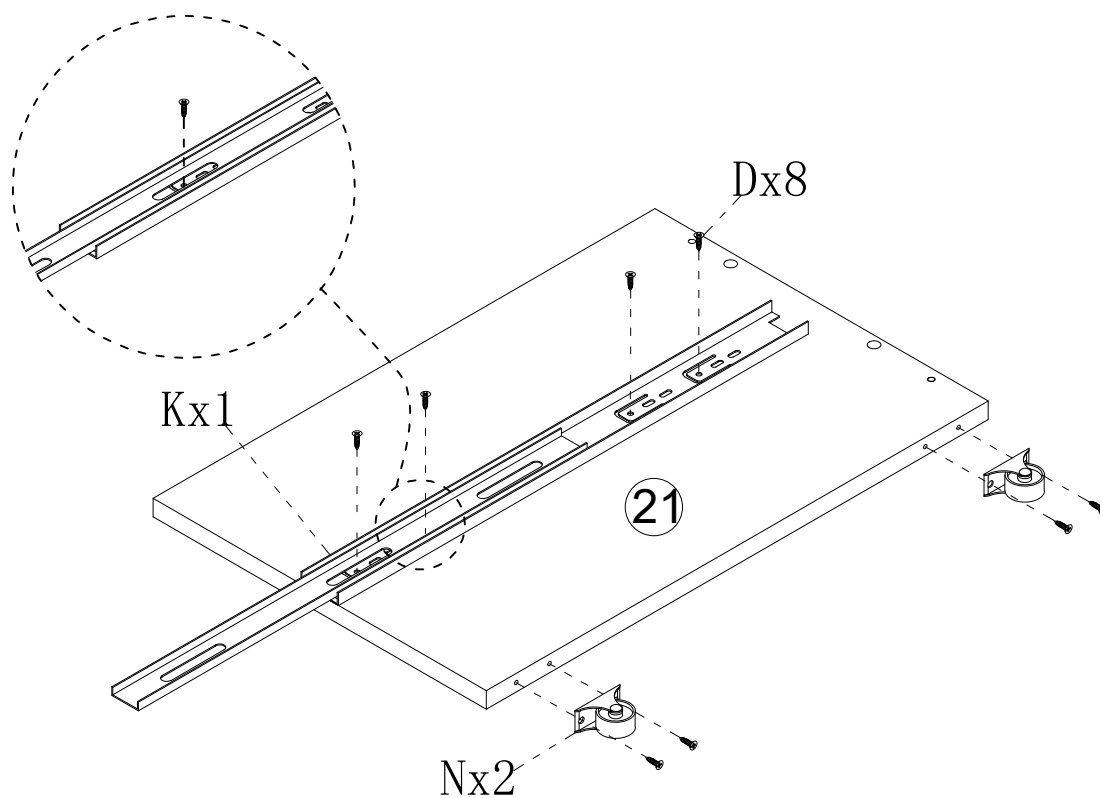
Place rail (K) and pulleys (N) on the holes on board (21) and secure them with screws (D).

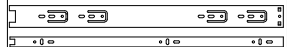



D	 Ø3.5x14	11
K		1
N		2

Step: 18

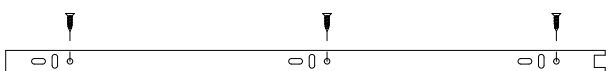
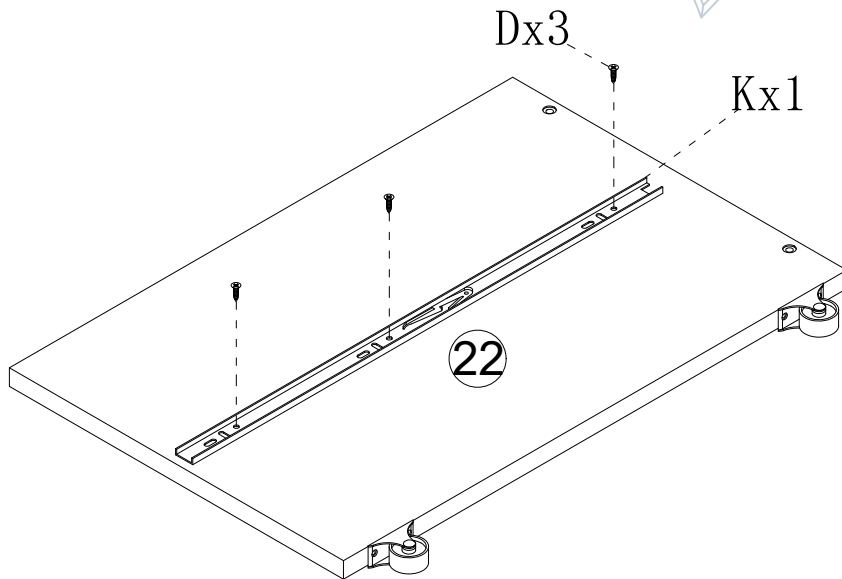
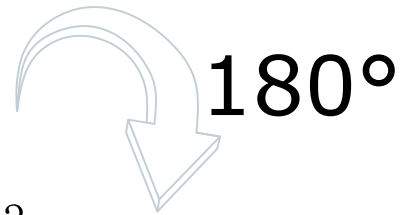
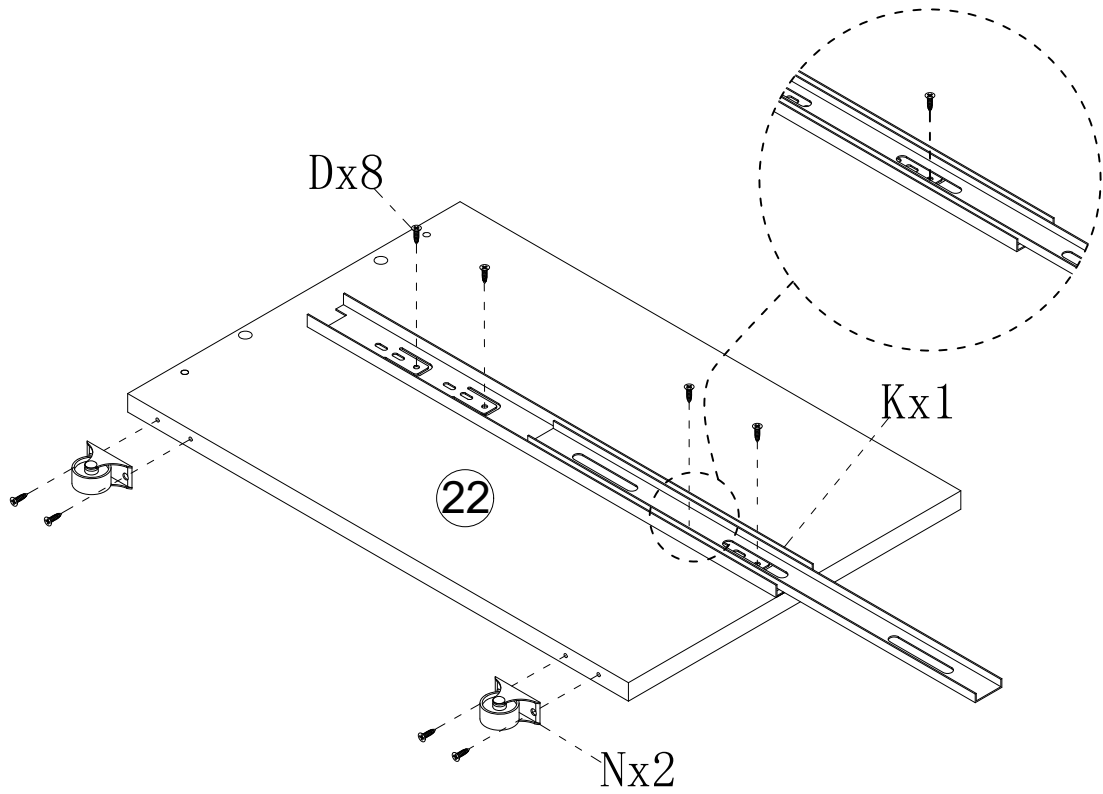
Place rail (K) and pulleys (N) on the holes on board (22) and secure them with screws (D).

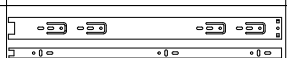

D	 Ø3.5x14	11
K		1
N		2

Step: 19

Lock screw (A) into the corresponding holes on board (7).

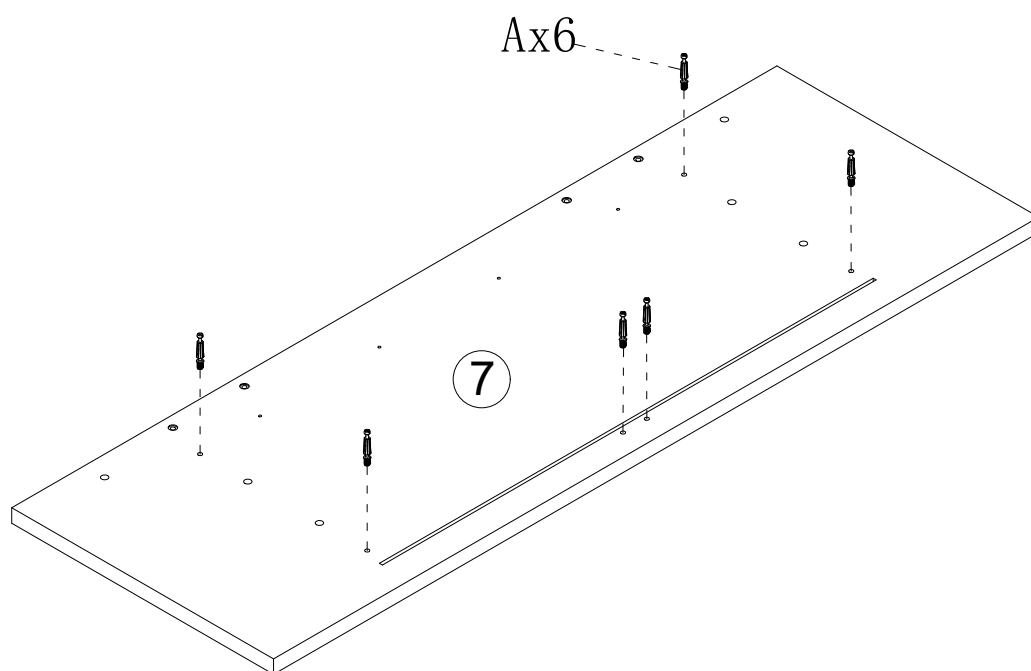

A





6

Step: 20

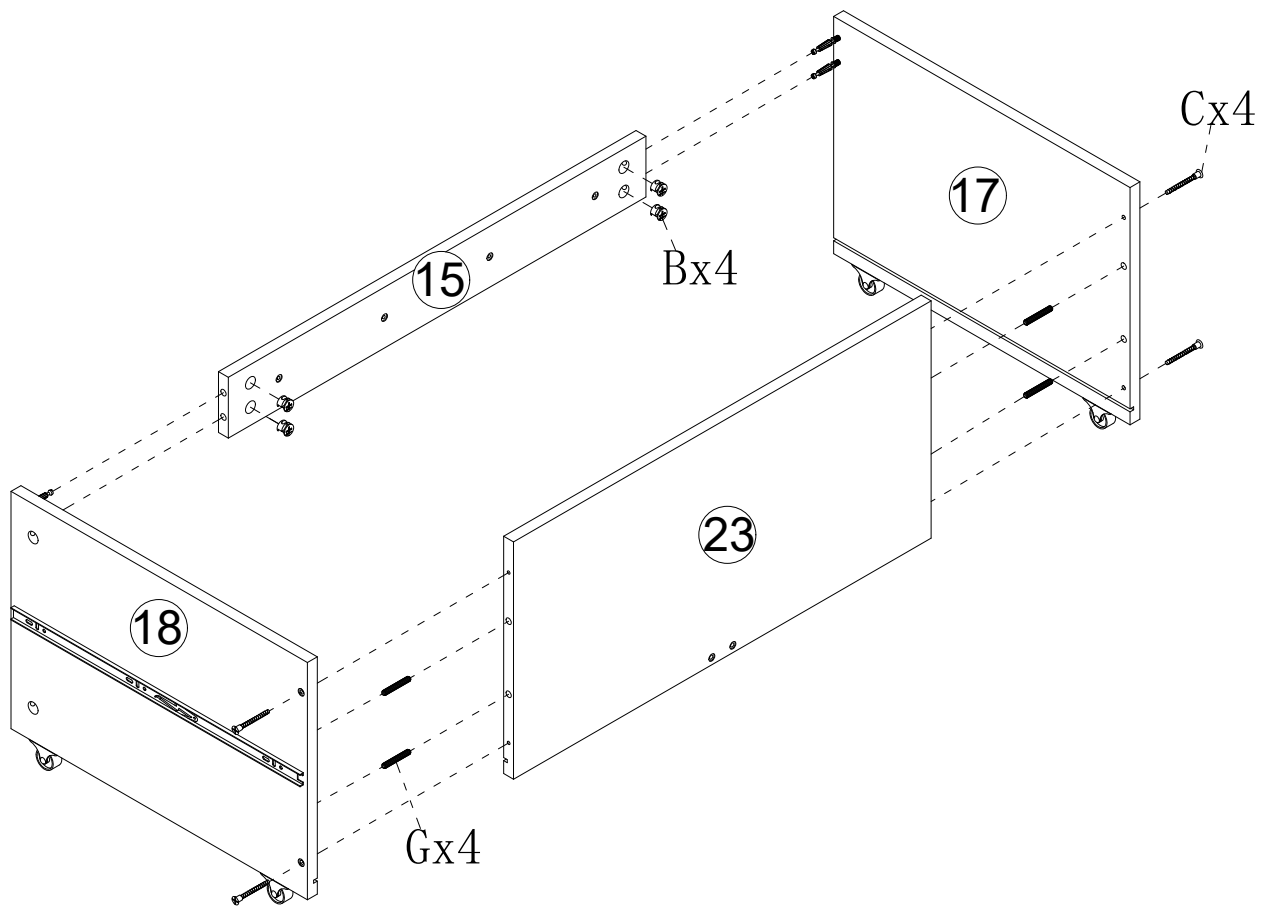
Just assemble Panels 15, 17, 18 and 23 at the corresponding hole positions using Cam Locks (B), Wooden Dowels (G) and Cross Dowels (C).

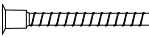

B		Ø15x11	4
C		Ø5x40	4
G		Ø8x40	4

Step: 21

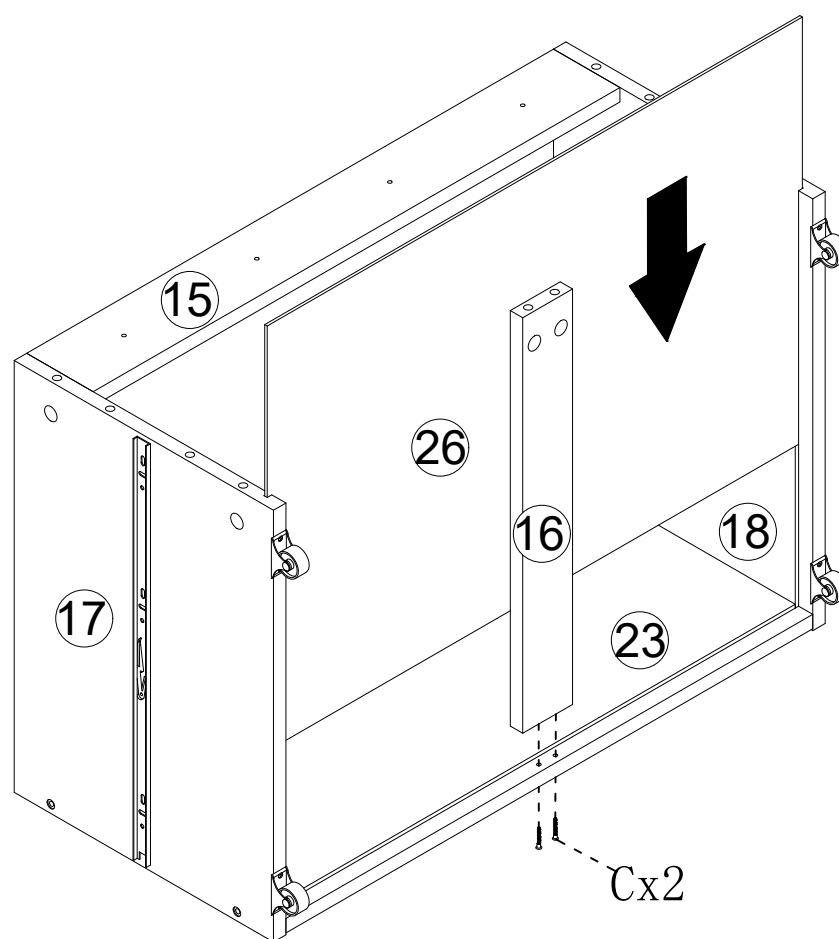

First, fit Panel 26 into the back panel groove according to the steps. Then, simply assemble Panel 16 at the corresponding hole positions using Cross Dowels (C).

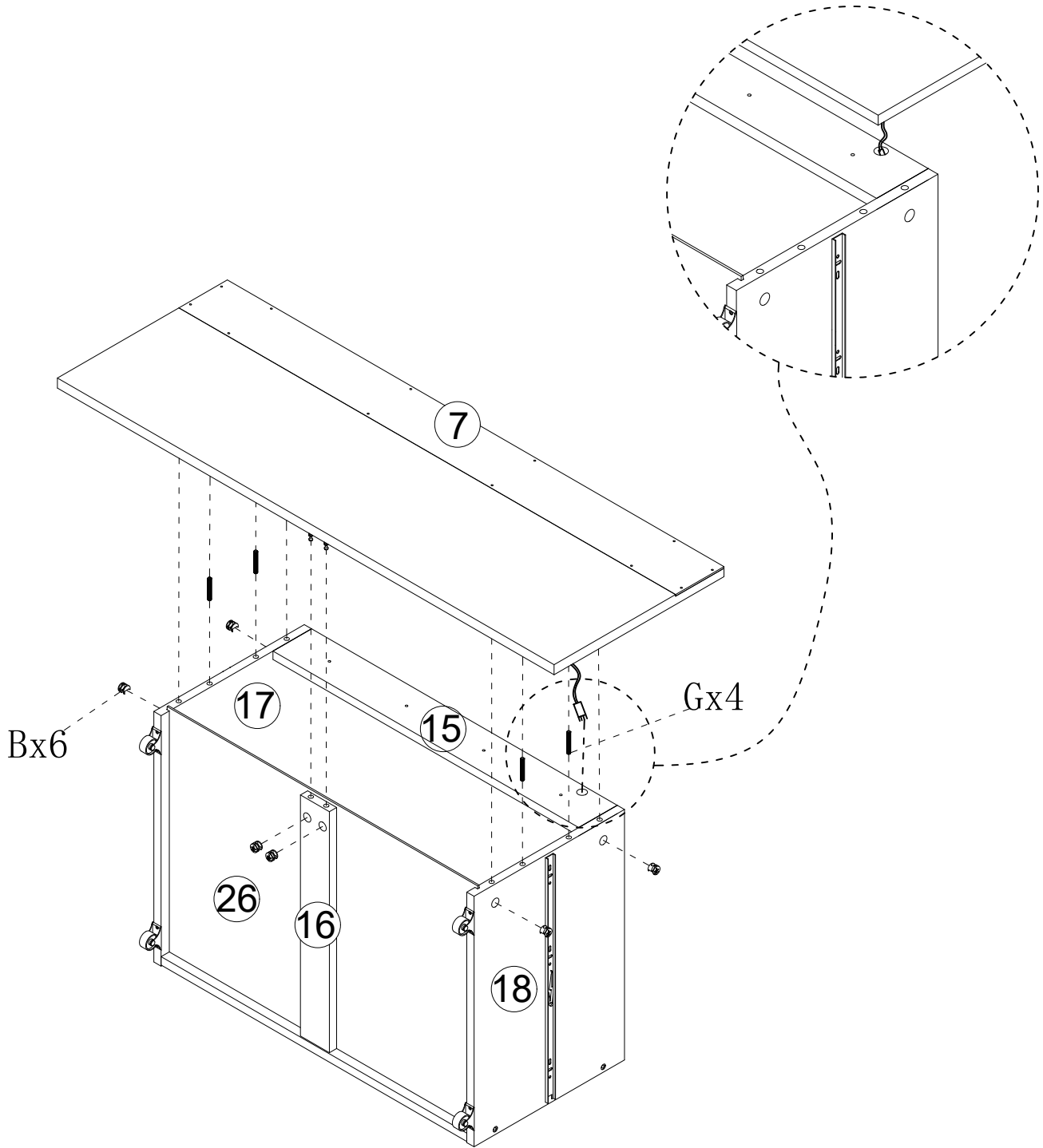

Step: 22

Secure board (7) with eccentrics (B) and wooden dowels (G).  
Feed the light strip connector into the wire access hole on Panel 15.



B		Ø15x11	6
G		Ø8x40	4

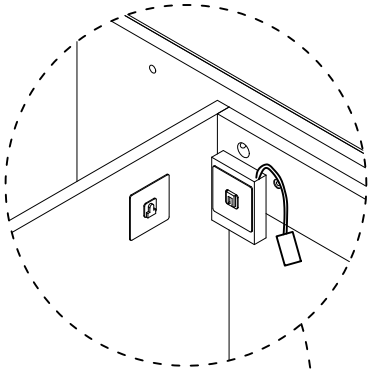

Step: 23

Connect board (15) to board (7) using screws (E).

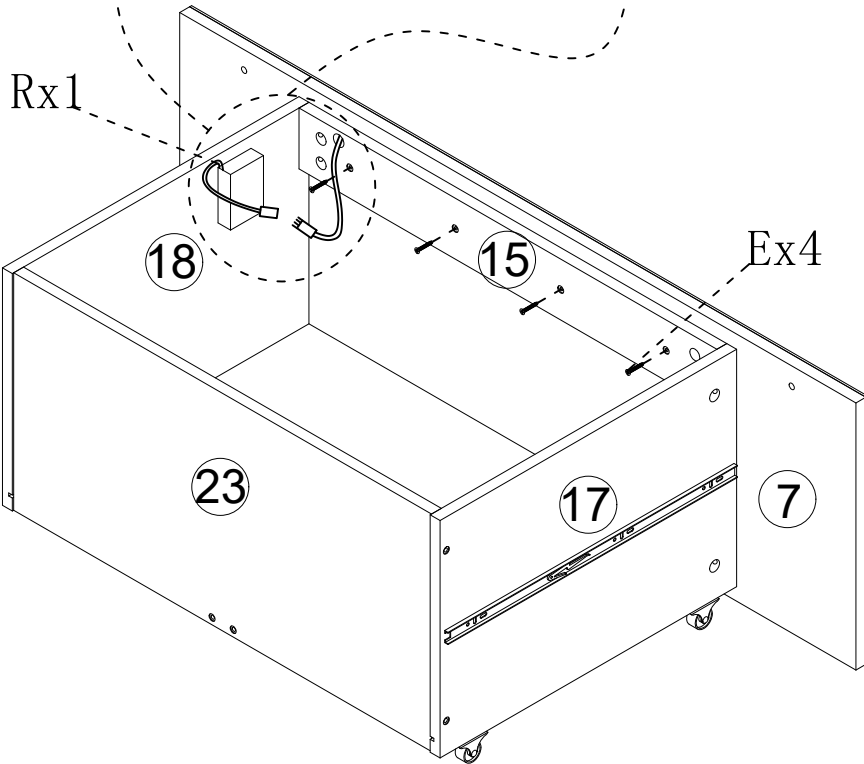
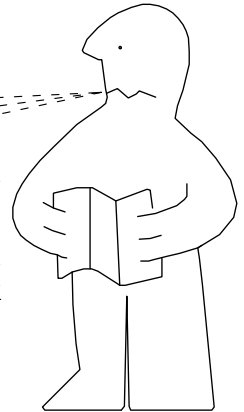

Attach the battery compartment with hooks and connect the light strip port to the battery compartment port.

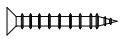



E		Ø4x25	4
R			1

Step: 24

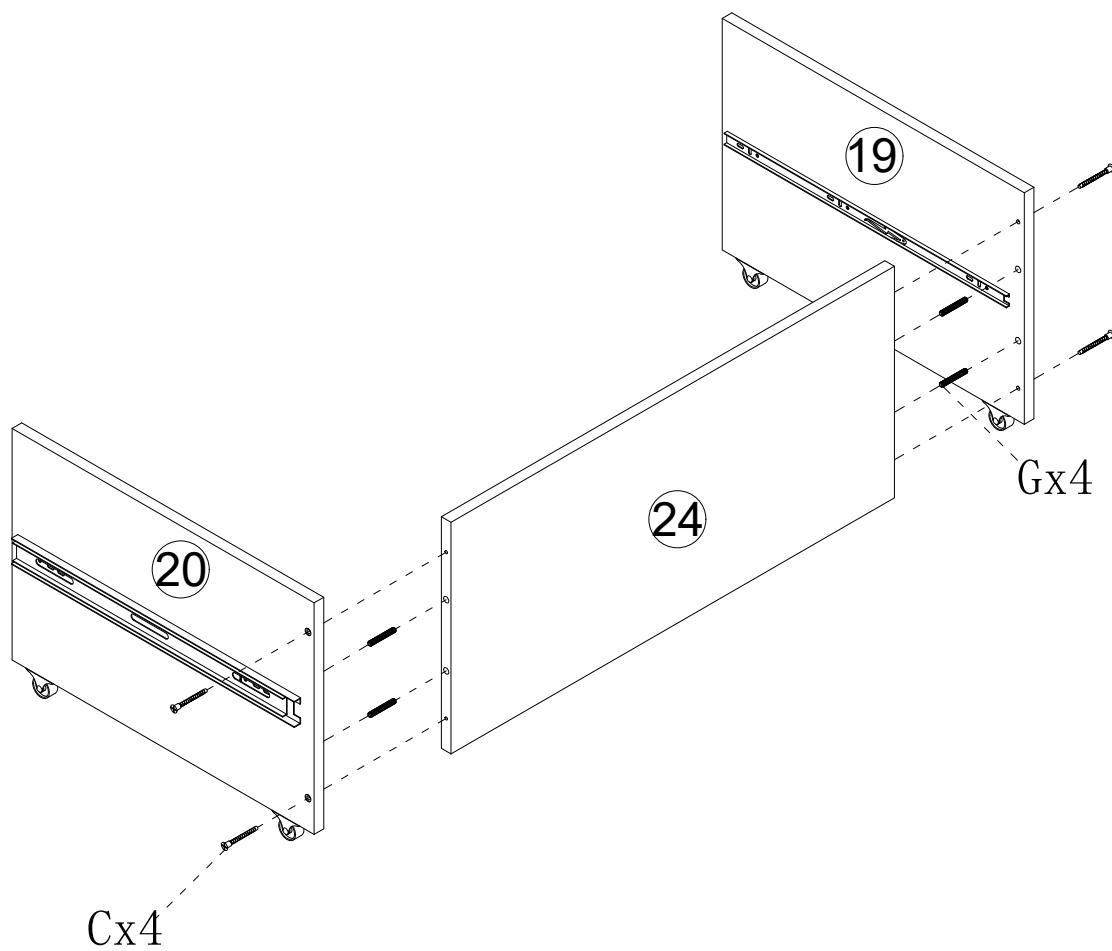
Assemble boards (19, 20 and 24) with screws (C) and wooden dowels (G).

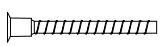



C	 Ø5x40	4
G	 Ø8x40	4

Step: 25

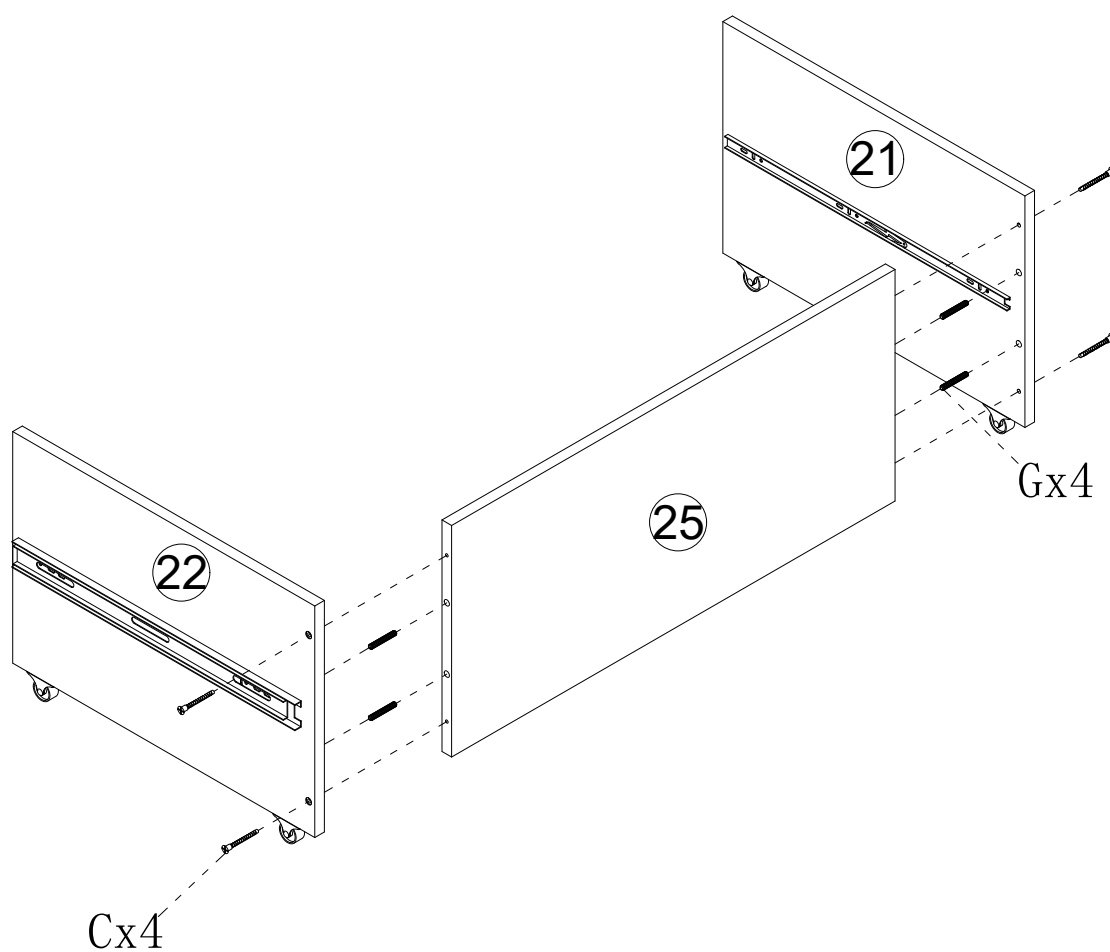
Assemble boards (21, 22 and 25) with screws (C) and wooden dowels (G).

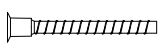

C	 Ø5x40	4
G	 Ø8x40	4

Step: 26

Push the drawer assembled in Step 25 inward to overlap the slide rails.

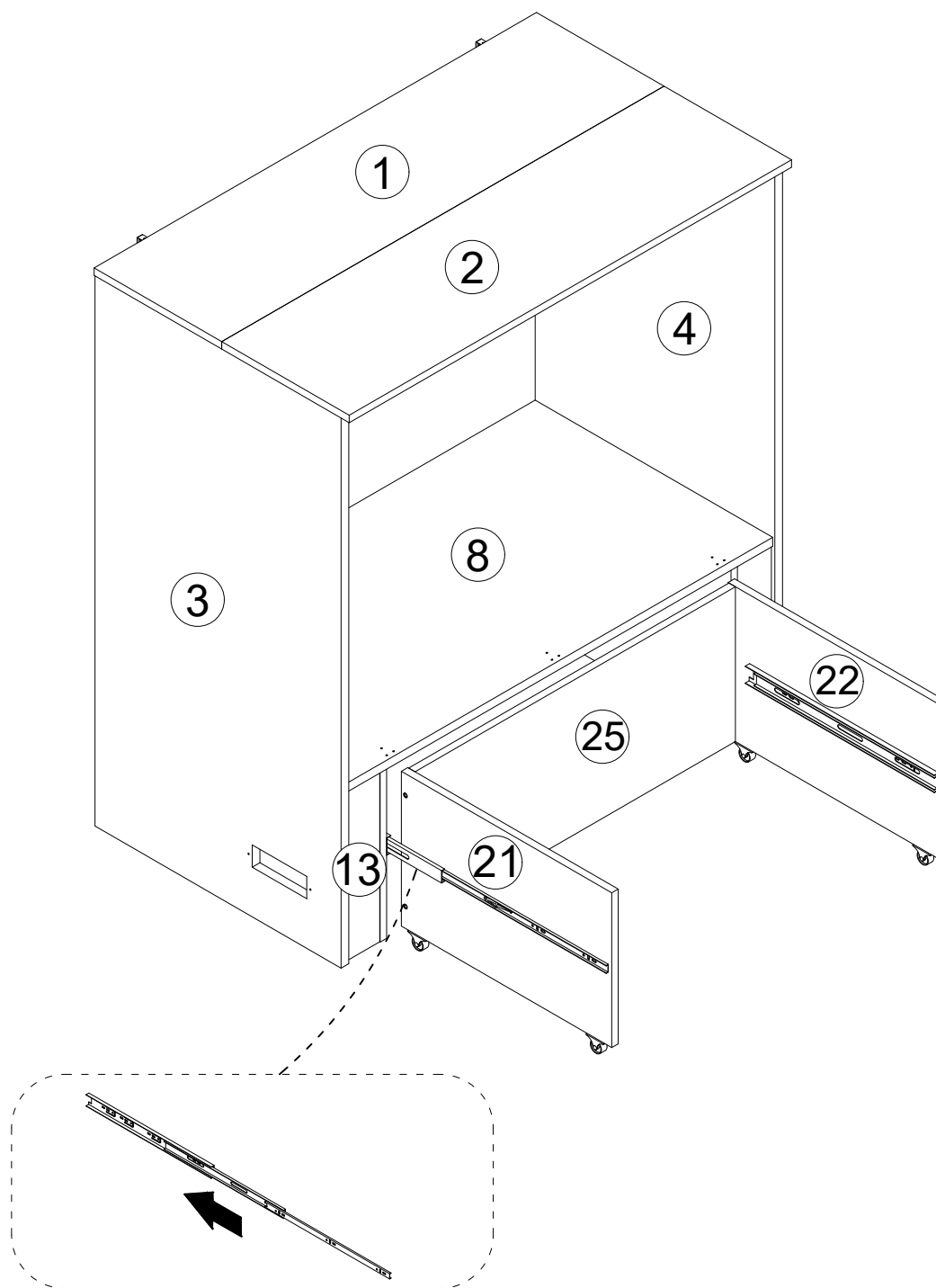

Step: 27



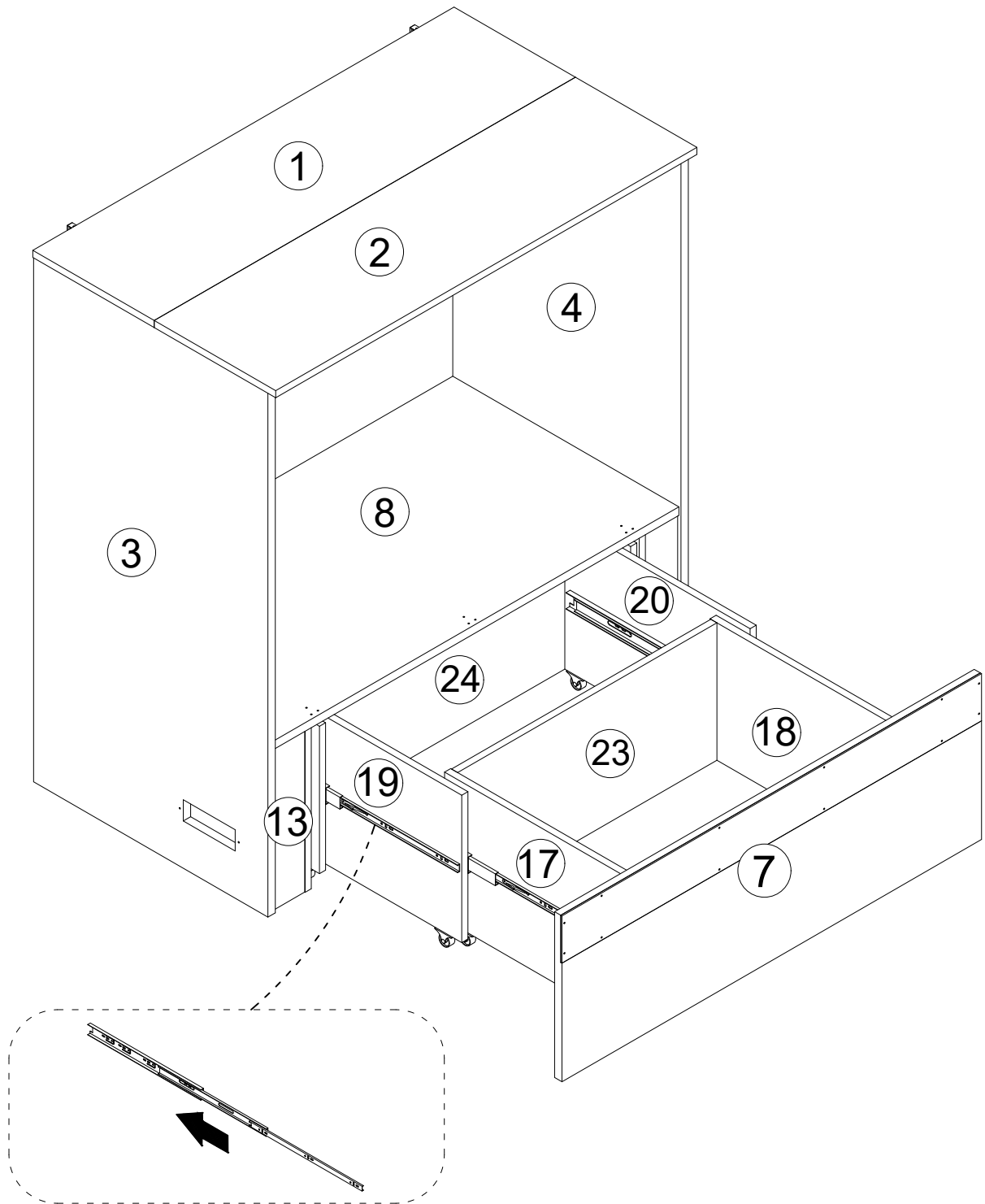

Push the drawers assembled in Steps 23 and 24 inward one after another to overlap the slide rails.

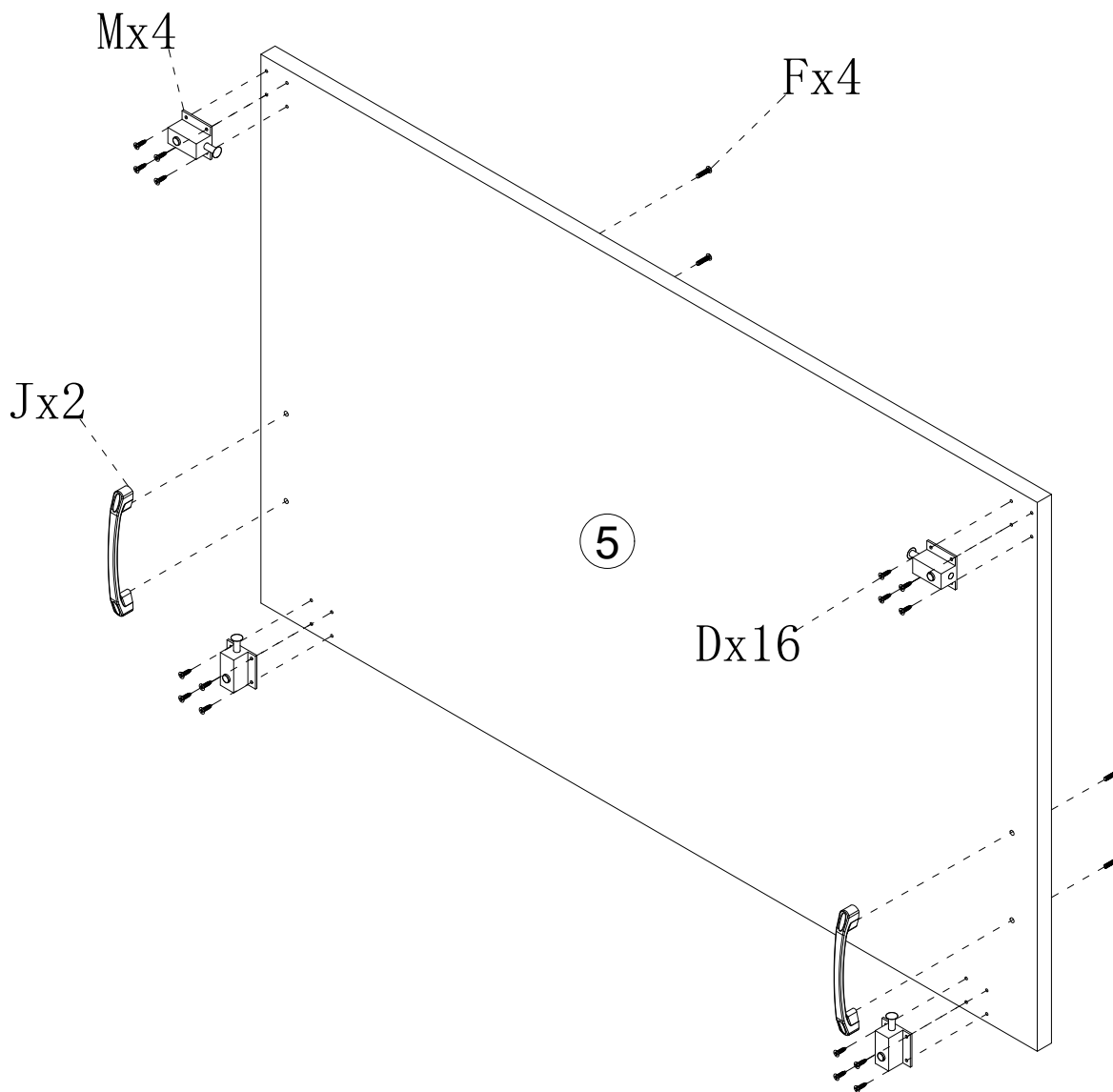

Step: 28

Secure handles (J) and latches (M) to the corresponding holes on board (5) using screws (D) and (F).





D	 Ø3.5x14	16
F	 M4x22	4
J		2
M		4

Step: 29

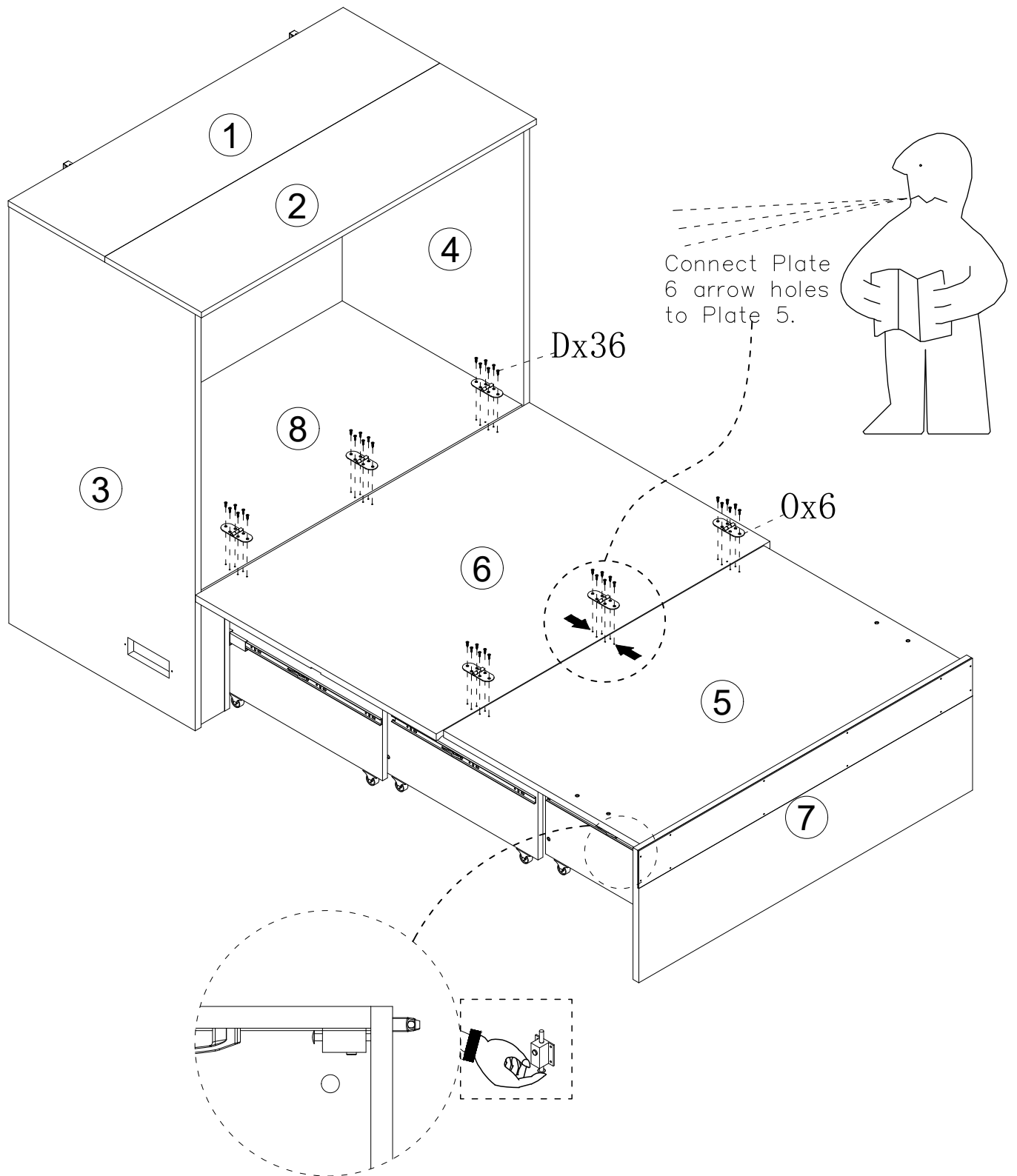
Pull out the drawers, place boards (6 and 5) on top, and secure them with hinges (0) and screws (D).



D	 Ø3.5x14	36
0		6

Step: 30

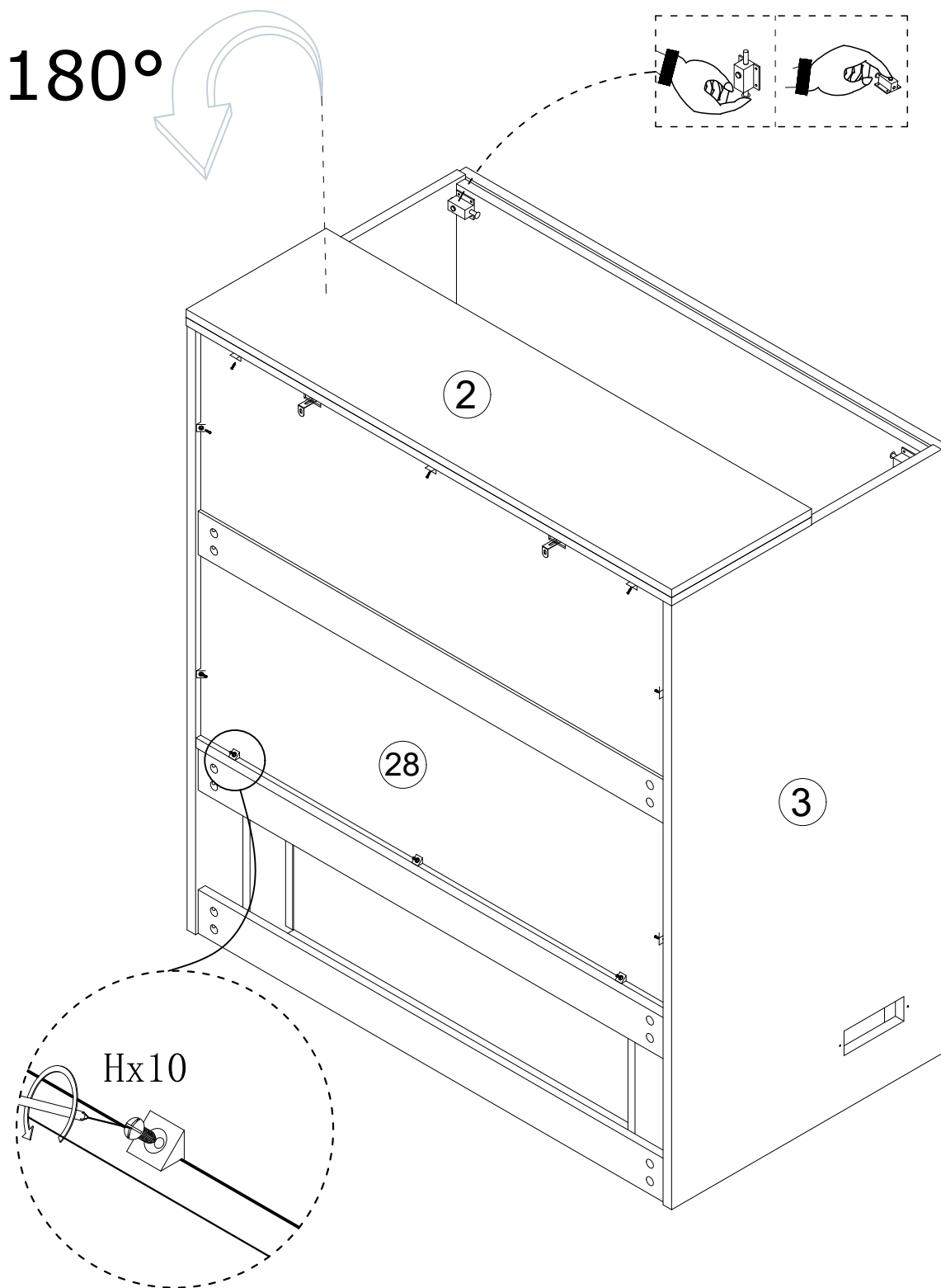

Flip up boards (6 and 5) and lock them into place with latches (N). Secure the back board with buckles and screws (H).

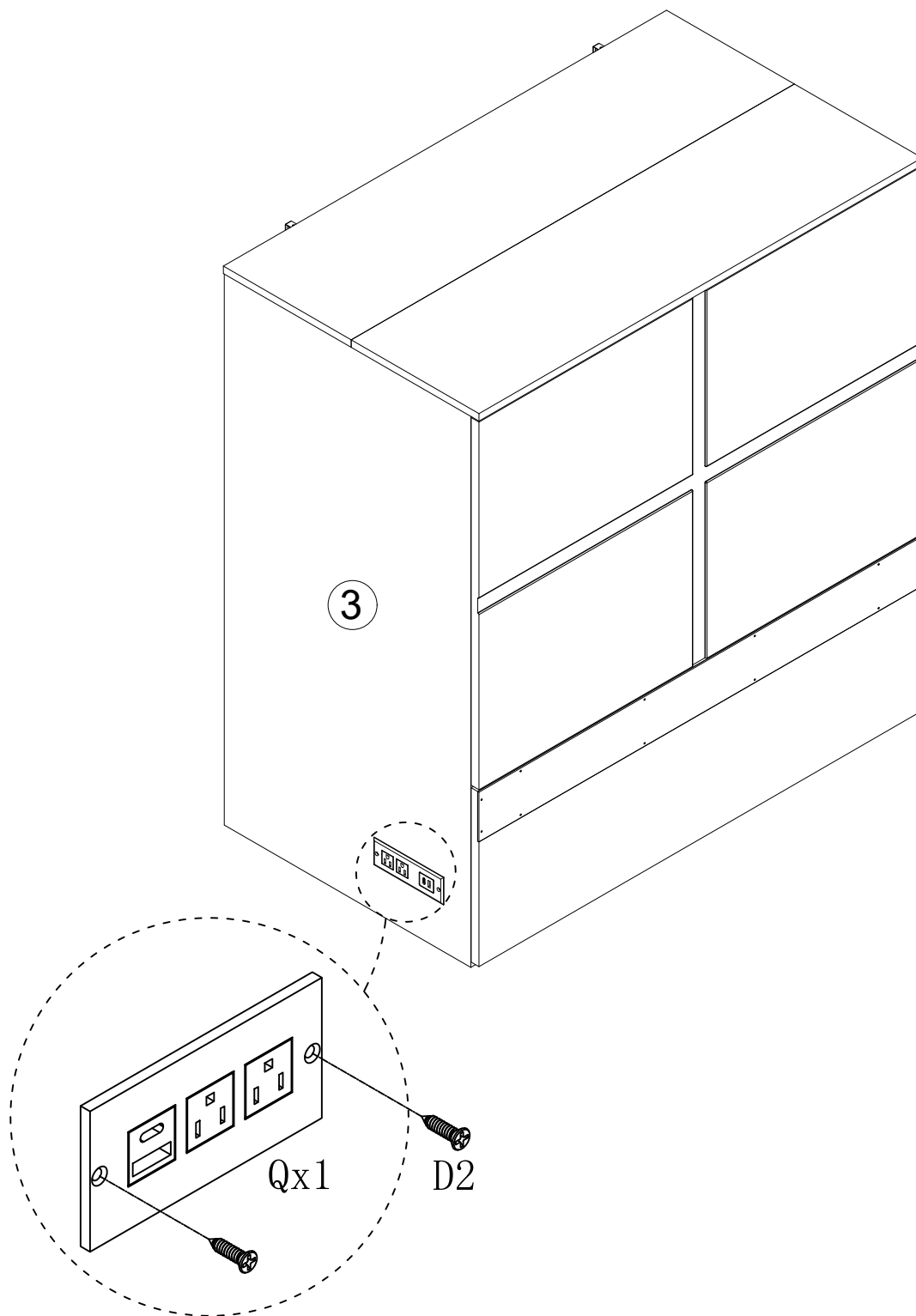

Step: 31

Secure sockets (Q) with screw (D).



D	 Ø3.5x14	2
Q		1

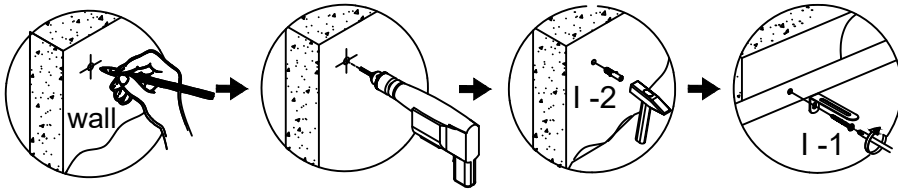

A solid wall	B cavity wall	C solid wood
Ø 8mm (5/16°)	Ø 8mm (5/16°)	Ø 3mm (Ø 1/8°)

**Warning:** If you overturn the furniture, it may cause serious or fatal crushing injuries. We have a wall connection device attached, please use it to hold the furniture following these instructions.

1. Mark the corresponding hole positions where you want to place the furniture;
2. Use a impact drill to drill holes and pay attention to avoid wires and water pipes;
3. Knock the expansion pipes into the wall holes;
4. Place the furniture in the corresponding position and tighten the wall connection device with screws.

Wall

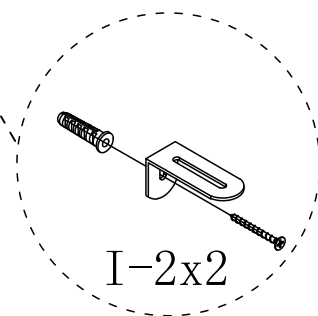
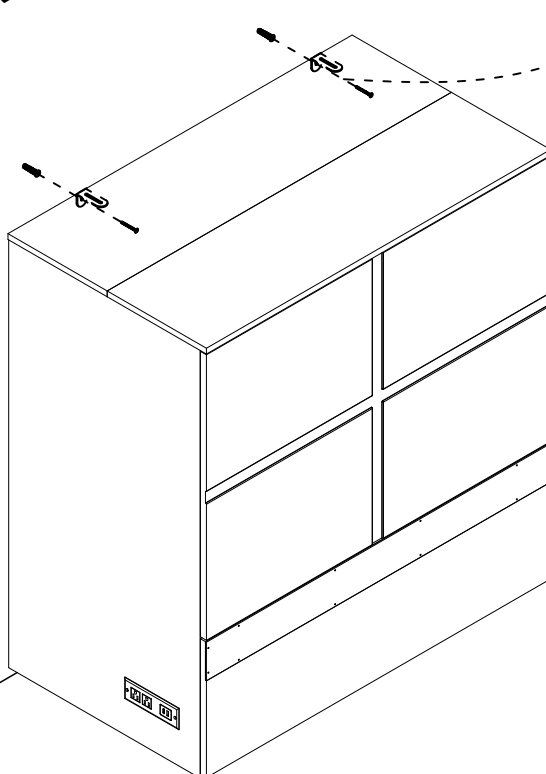

**CA WARNING:** This product can expose you to chemicals including **Wood Dust**, which is known to the State of California to cause cancer. For more information go to <https://www.P65Warnings.ca.gov>