

Item NO:CT01 & CT04 Coffee table

Assembly Instruction

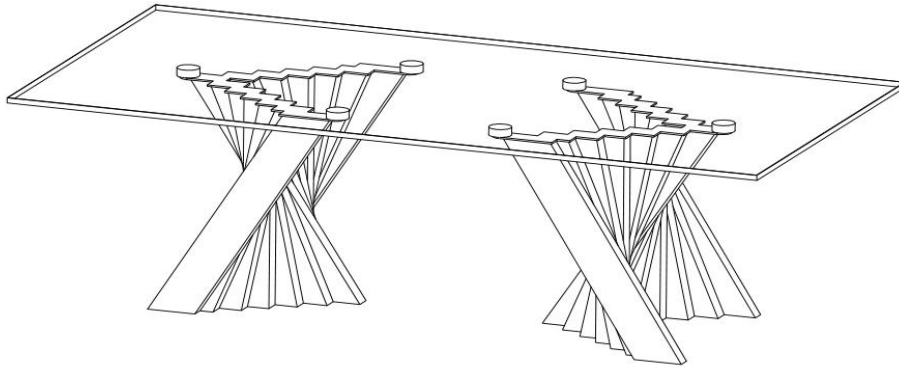

ASSEMBLY TIME PER UNIT:

20MINUTES

PARTS IDENTIFICATION

B1:TOP GLASS

A TOP GLASS

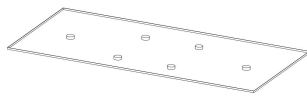

1pc



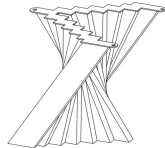

B2:BASE

B BASE



2pcs

HARDWARE LIST

NO.	DESCRIPTION	FIGURE	QTY
1	Allen wrench		1
2	Bolts		6
3	spring shim		6
4	Flat washer		6

Hardware pack is located in **BASE BOX**

STEP: 1

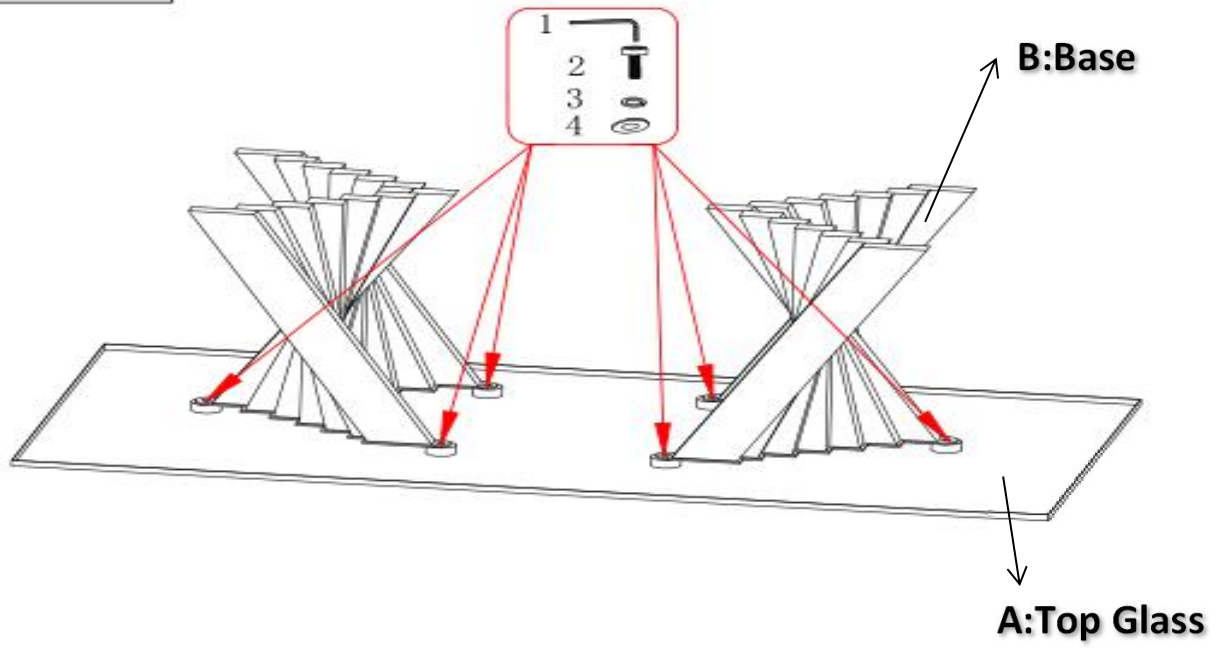

STEP: 2

