

# *ASSEMBLY INSTRUCTIONS*



## ***MEDIA TOWER***

# ASSEMBLY INSTRUCTIONS

## ASSEMBLY TIPS:

1. Remove hardware from box and sort by size.
2. Please check to see that all hardware and parts are present prior to start of assembly.
3. Please follow attached instructions in the same sequence as numbered to assure fast & easy assembly.



### WARNING!

1. Don't attempt to repair or modify parts that are broken or defective. Please contact the store immediately.
2. This product is for home use only and not intended for commercial establishments.



ASSEMBLY TIME

40 MINUTES



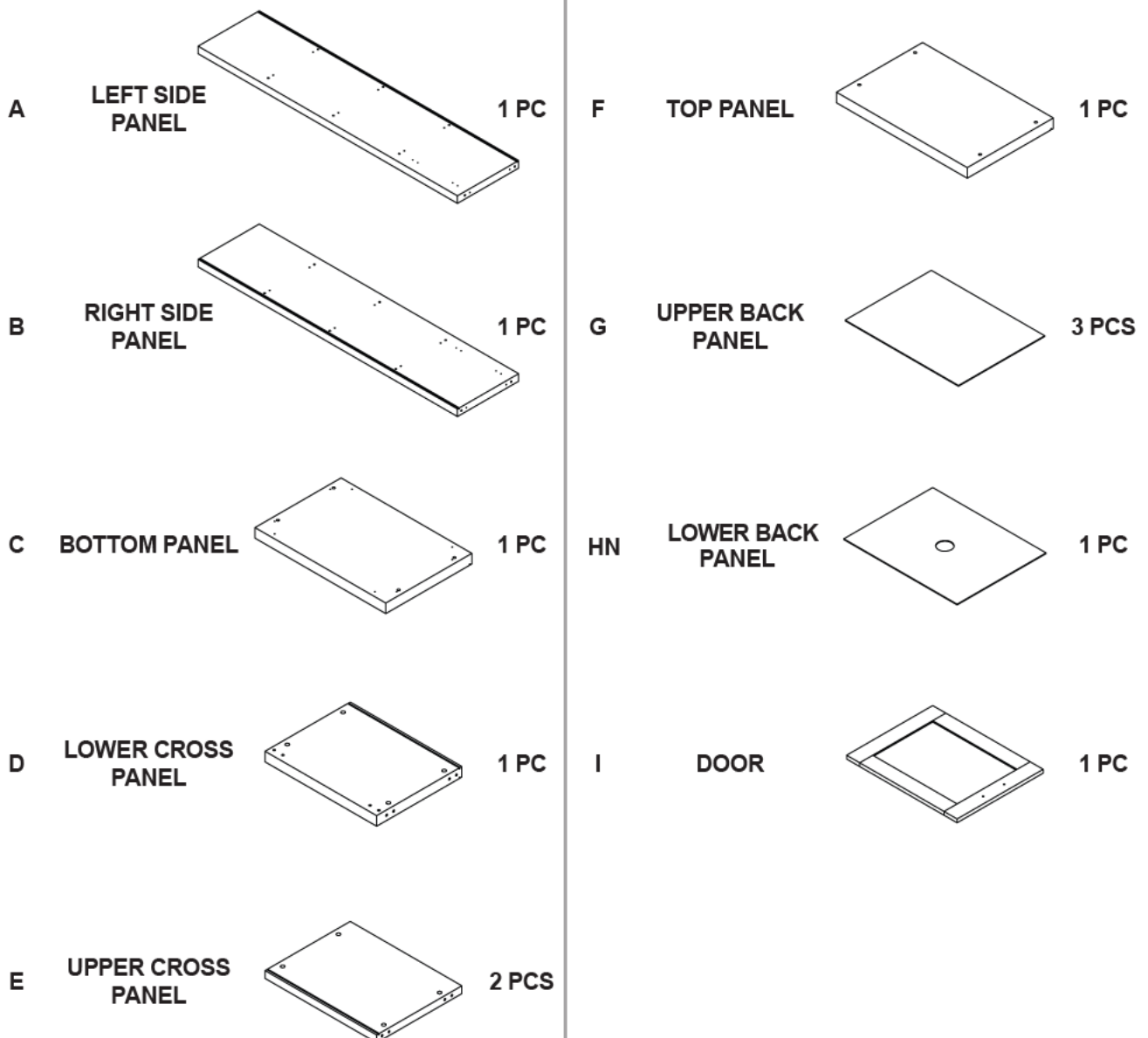





## PARTS IDENTIFICATION

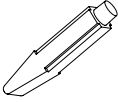

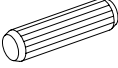
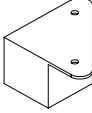
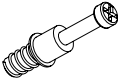
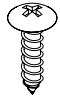
### NOTE:

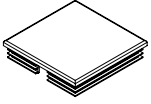
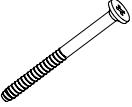
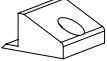
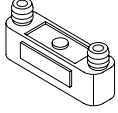
Phillips head screw driver is required in the assembly process; however, manufacturer does not provide this item.

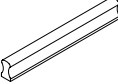
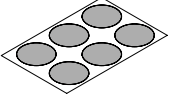
## HARDWARE IDENTIFICATION

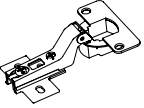
<b>Z</b>							
NO	DESCRIPTION	FIGURE	Q'TY	NO	DESCRIPTION	FIGURE	Q'TY
1	GLUE 15g		1 PC	10	HINGE SCREW ø4x15mm SR		8 PCS
2	WOODEN DOWEL ø8x30mm		20 PCS	11	LEG 47mm BLK		4 PCS
3	CAM BOLT ø7x35.5mm SR		12 PCS	12	SCREW ø4x19mm BLK		8 PCS
4	CAM LOCK ø15x12mm SR		12 PCS	13	SQUARE FLOOR PROTECTOR 50x50mm		4 PCS
5	BOLT ø9.5x55mm SR		8 PCS	14	FIXER		6 PCS
6	DOOR CATCH		1 PC	15	FIXER SCREW ø3x19mm SR		6 PCS
7	HANDLE L= 120mm BLK		1 PC	16	STICKER ø20mm		2 PCS
8	HANDLE BOLT ø4x28mm BLK		2 PCS	17	PLASTIC COVER ø 52mm		1 PC
9	HINGE ø35mm SR		2 PCS				

**Z7,Z8,Z9,Z11 not included in blister packaging.**

**NOTE:**

Phillips head screw driver is required in the assembly process; however, manufacturer does not provide this item.

# STEP 1

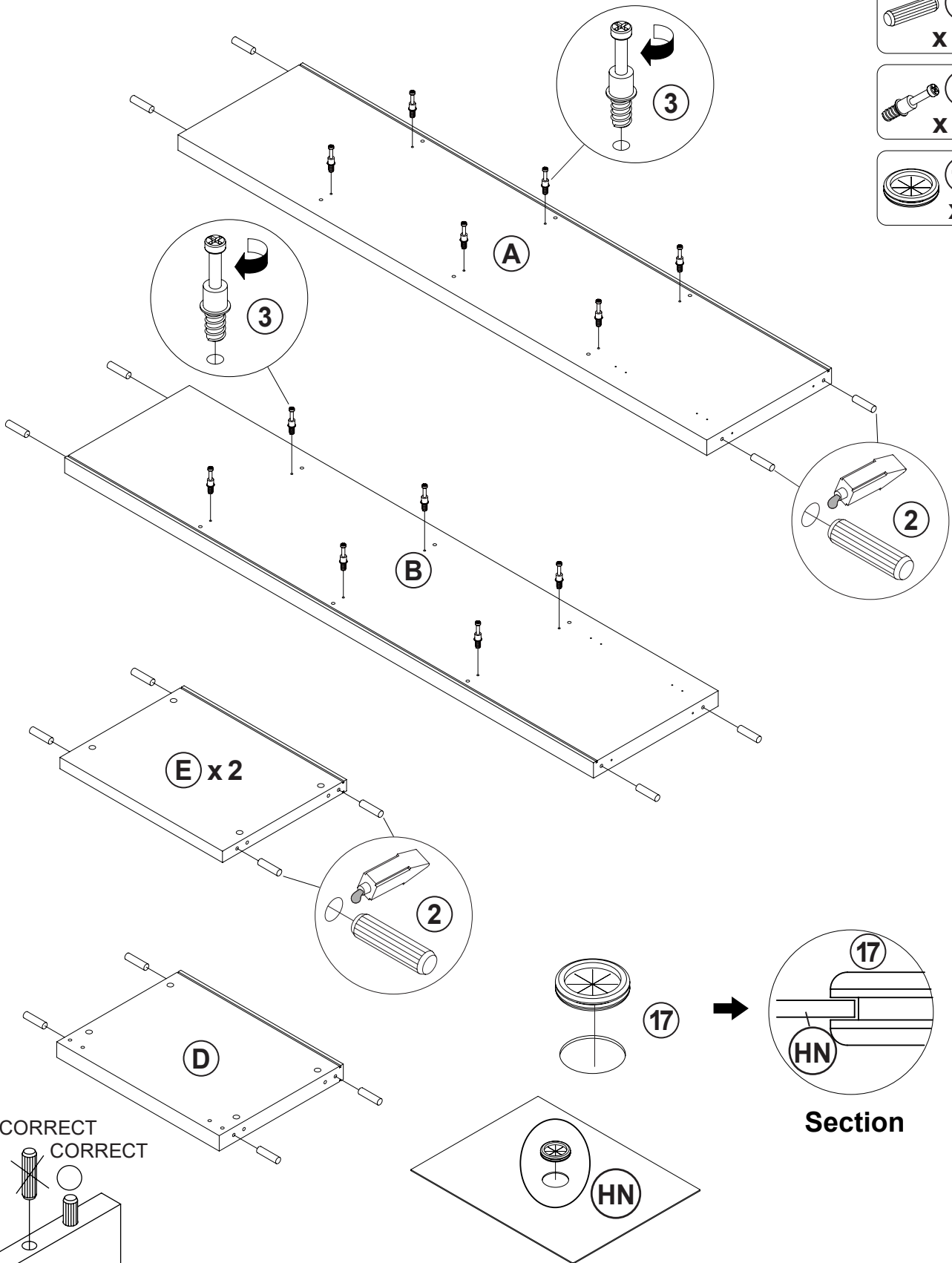
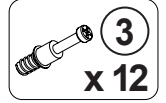
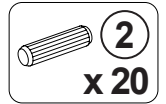

INCORRECT  
CORRECT

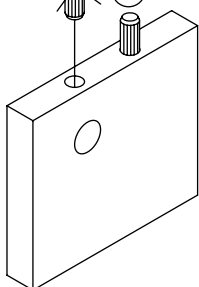

Apply glue on all wooden dowels to ensure integrity of the structure.

## STEP 2

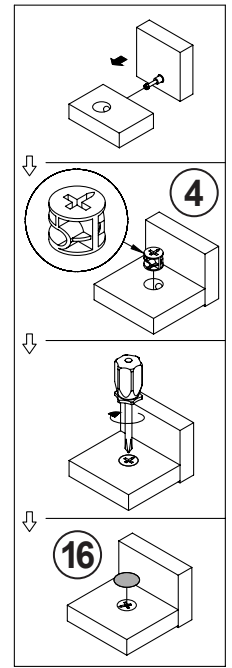
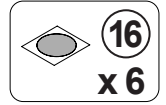
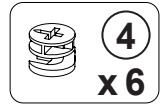
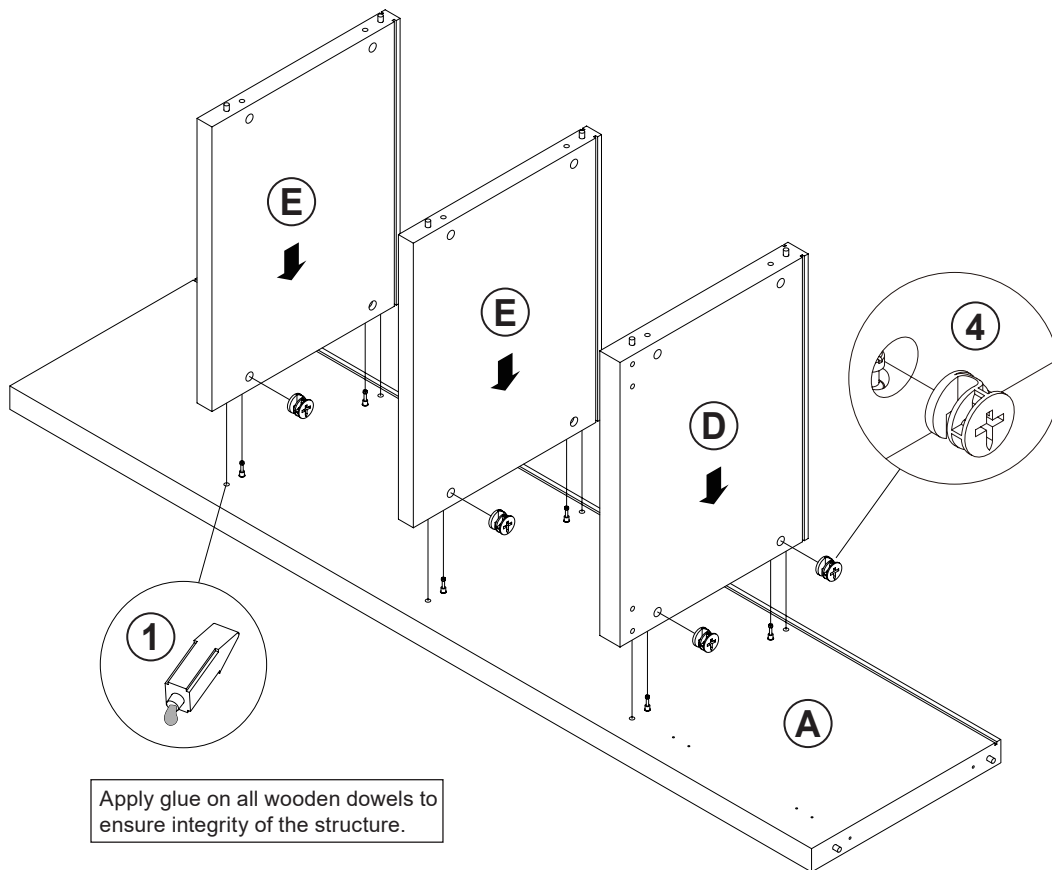

## STEP 3

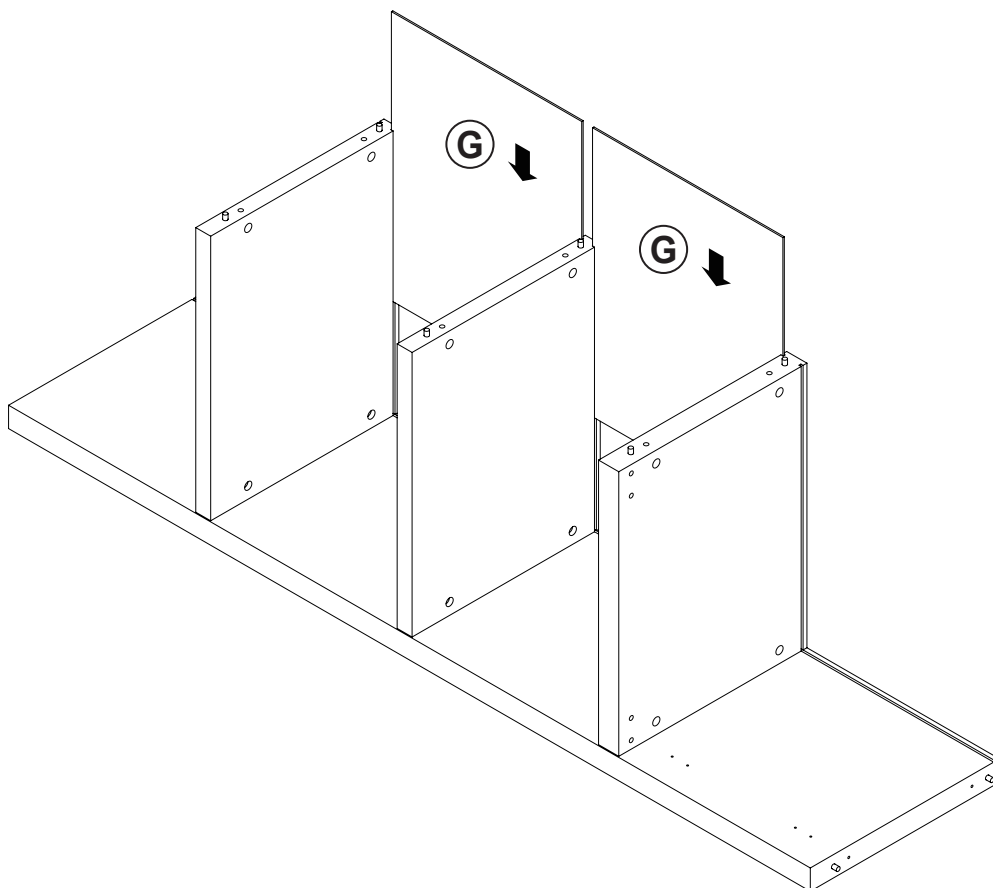

## STEP 4

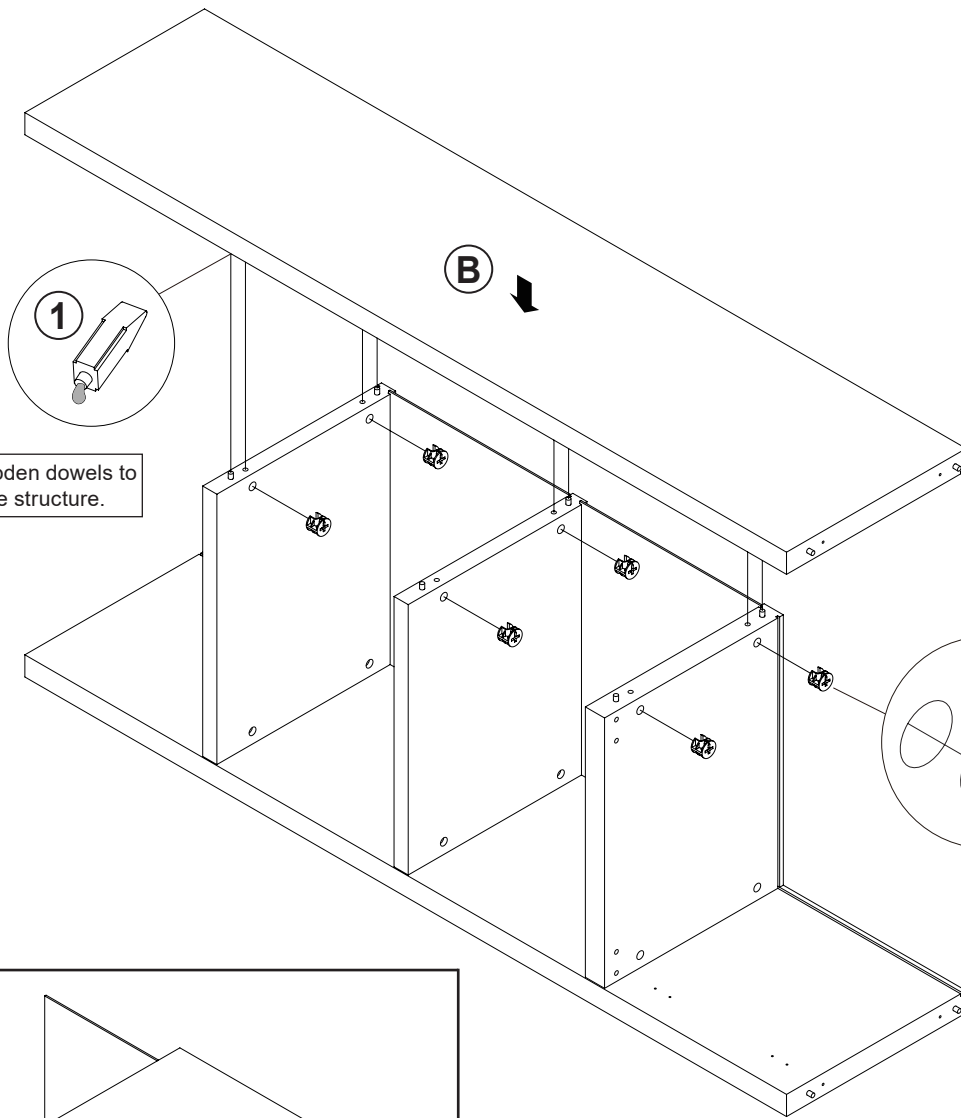
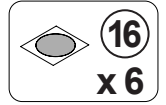
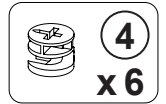

Apply glue on all wooden dowels to ensure integrity of the structure.

## STEP 5

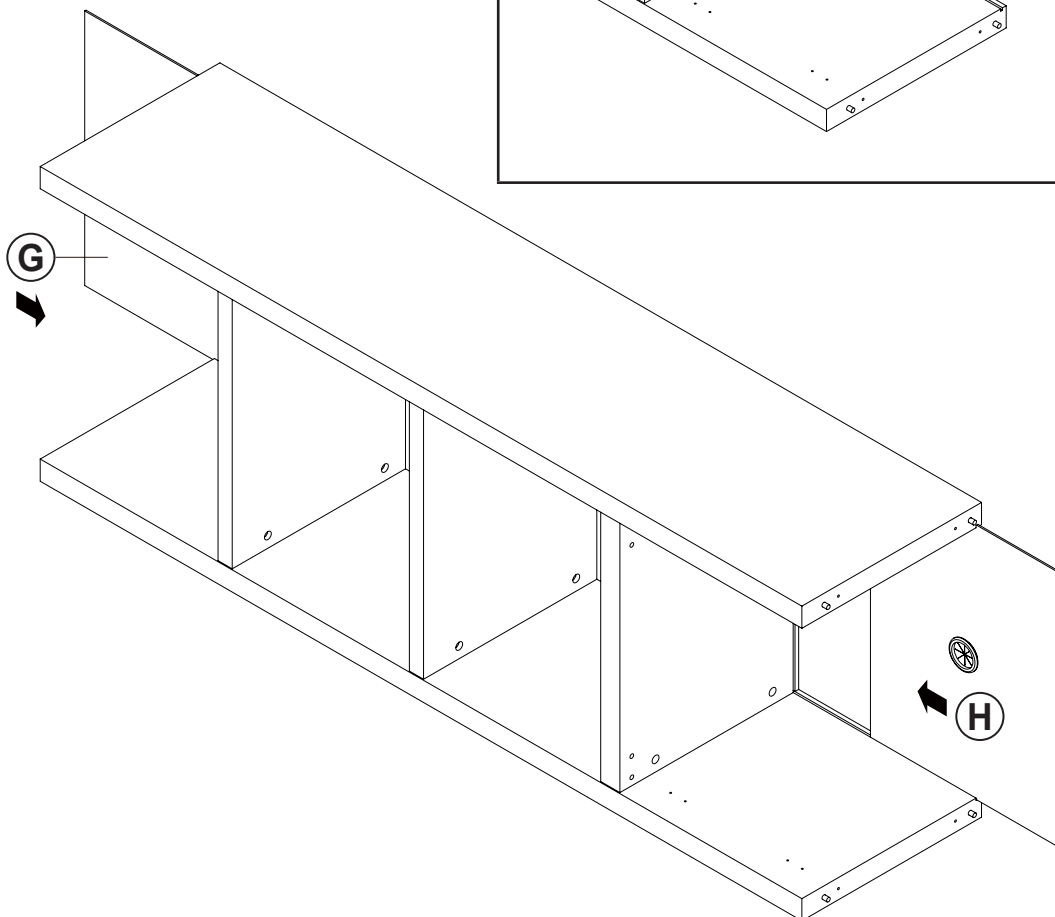

## STEP 6

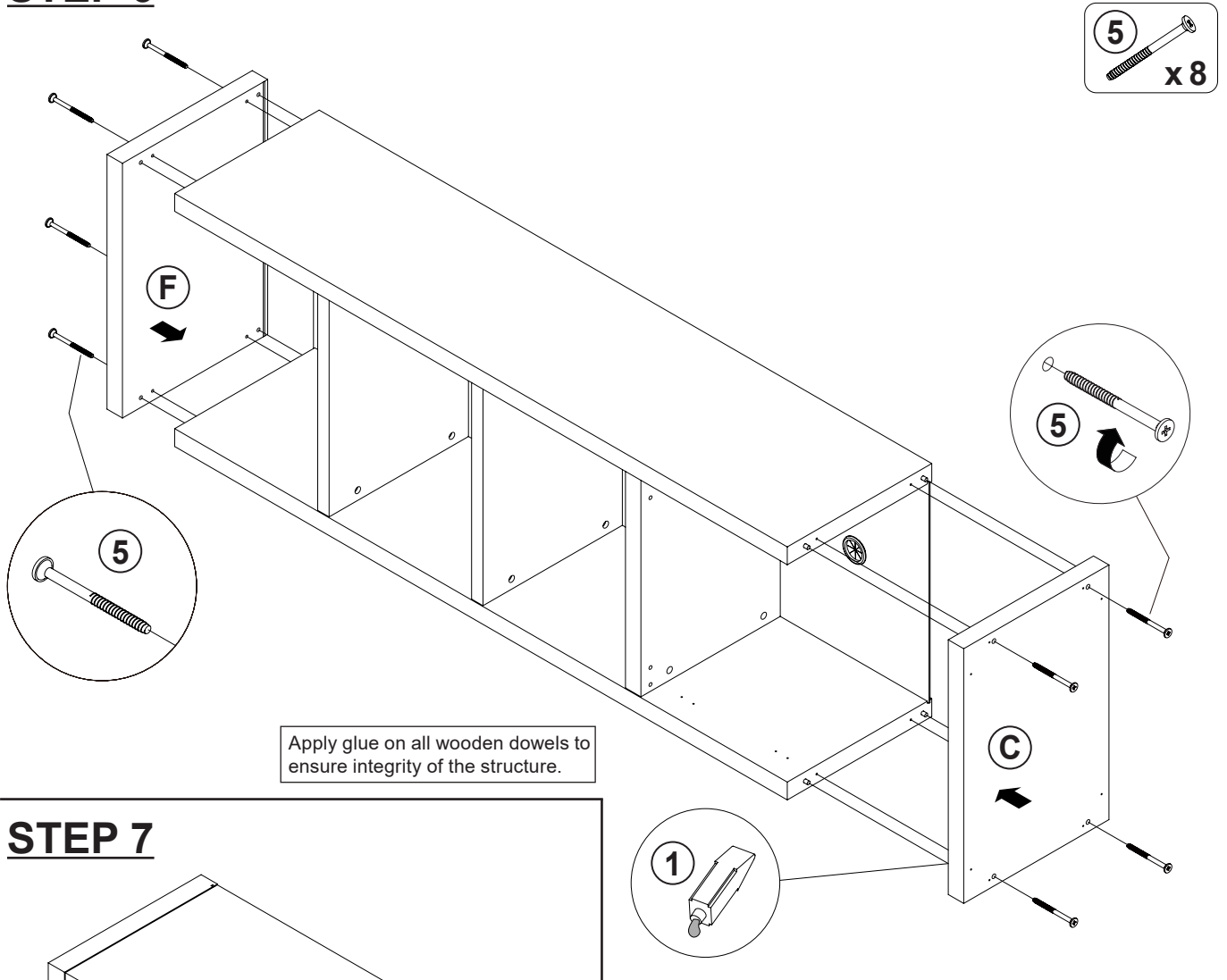

## STEP 7

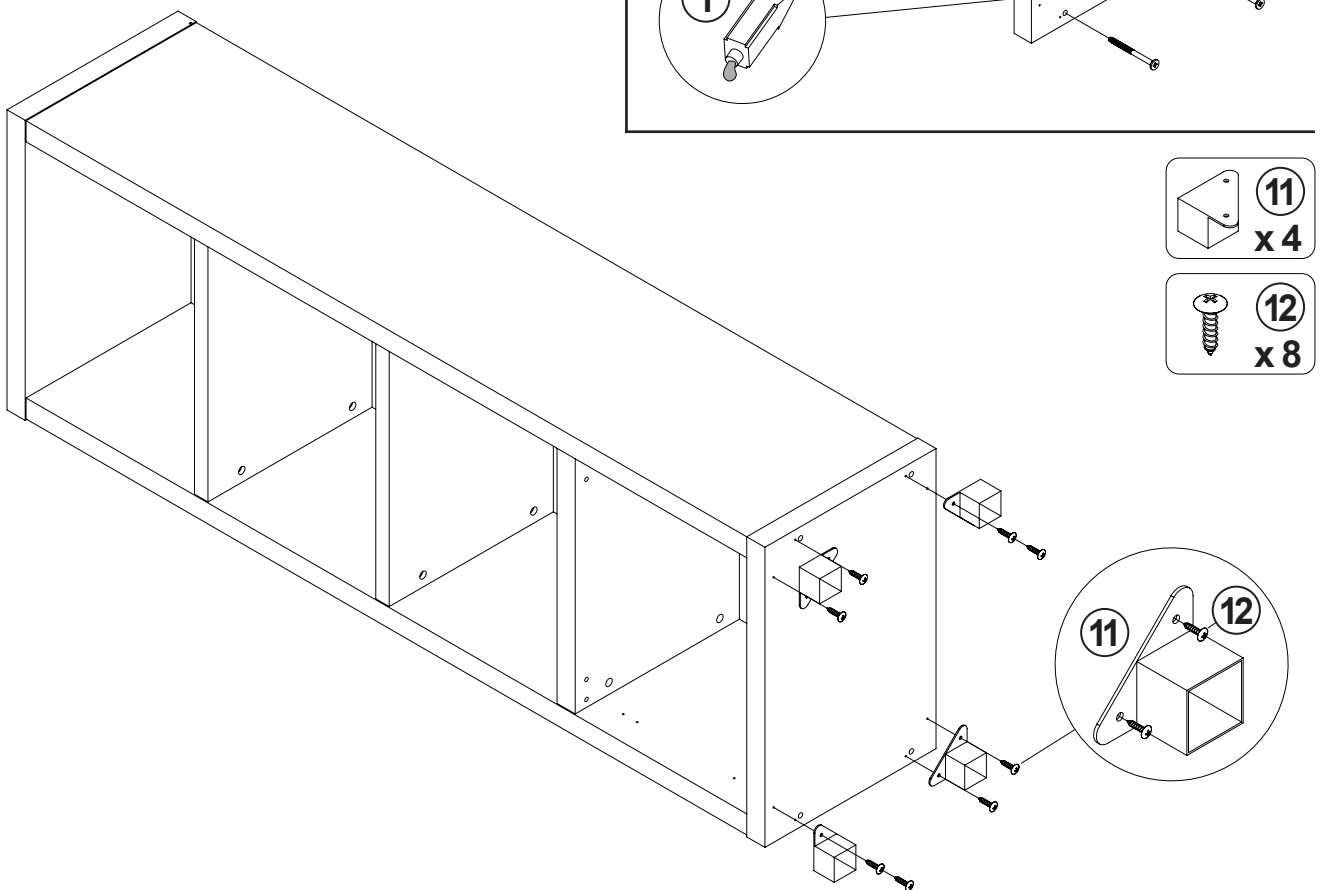

## STEP 8

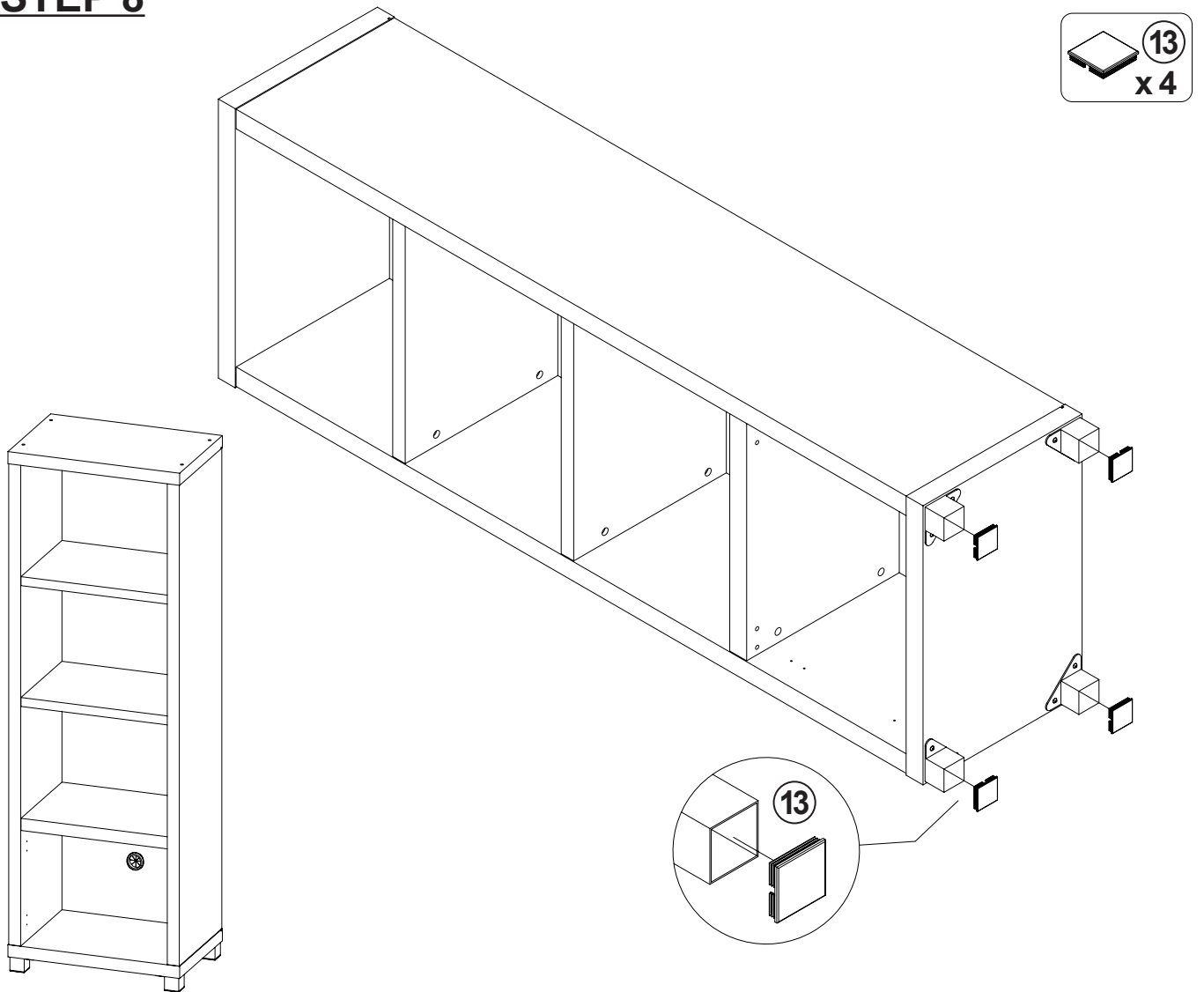

## STEP 9

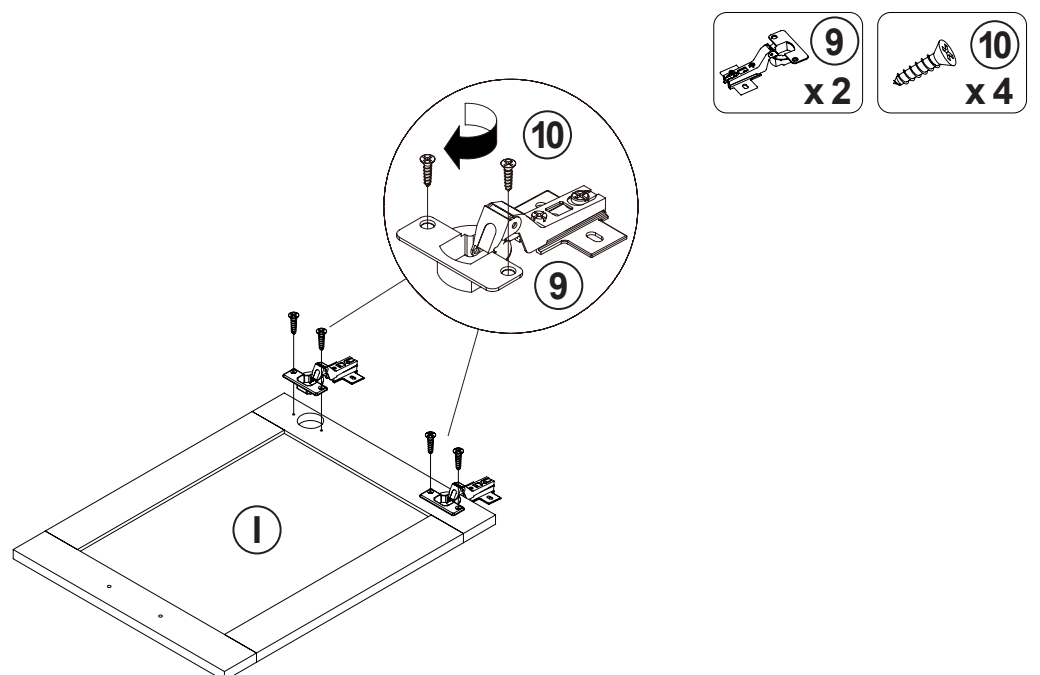

# STEP 10

LEFT

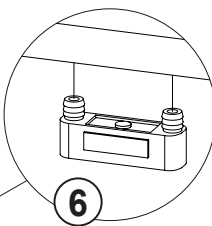
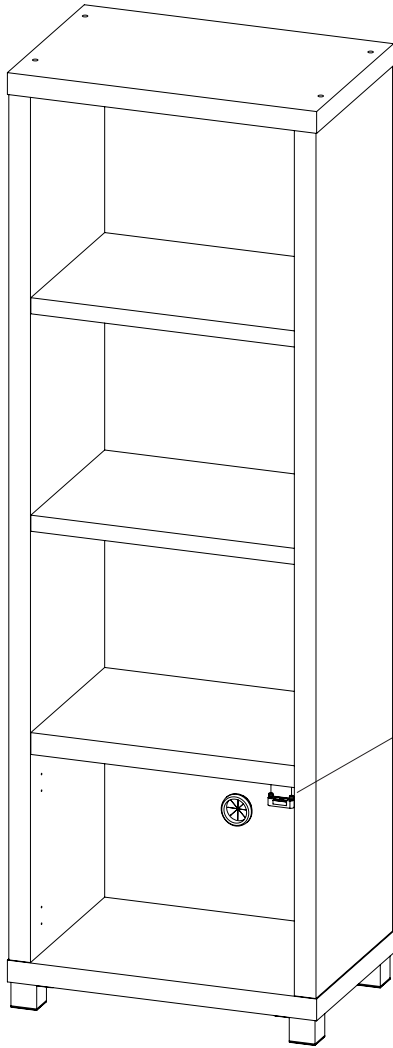
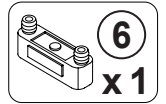

RIGHT

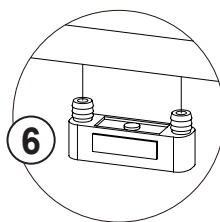
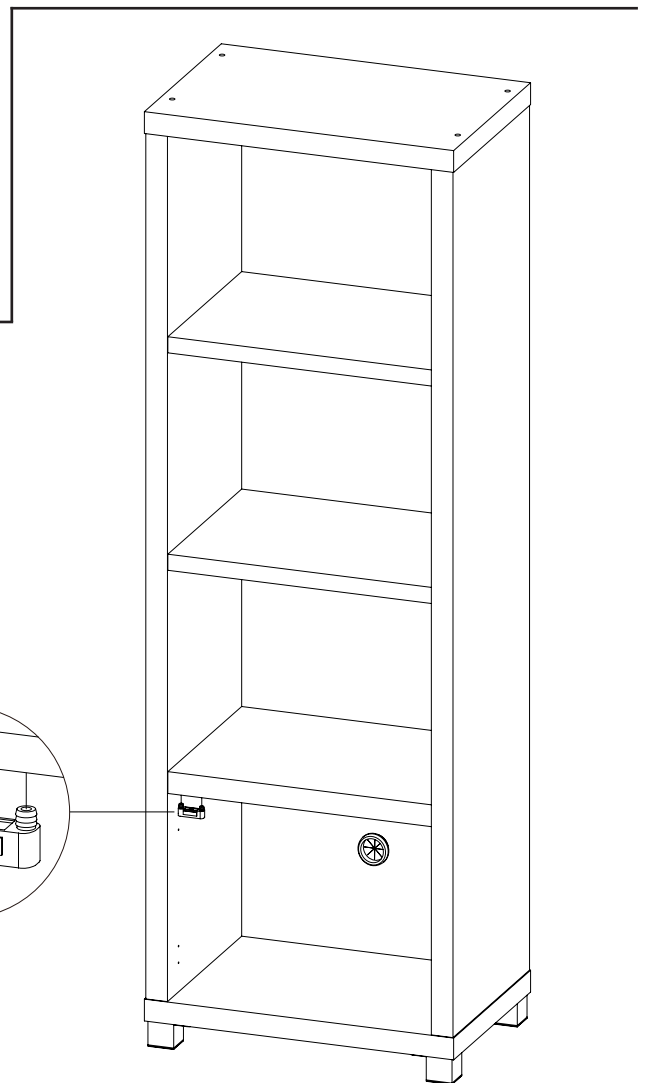

# STEP 11

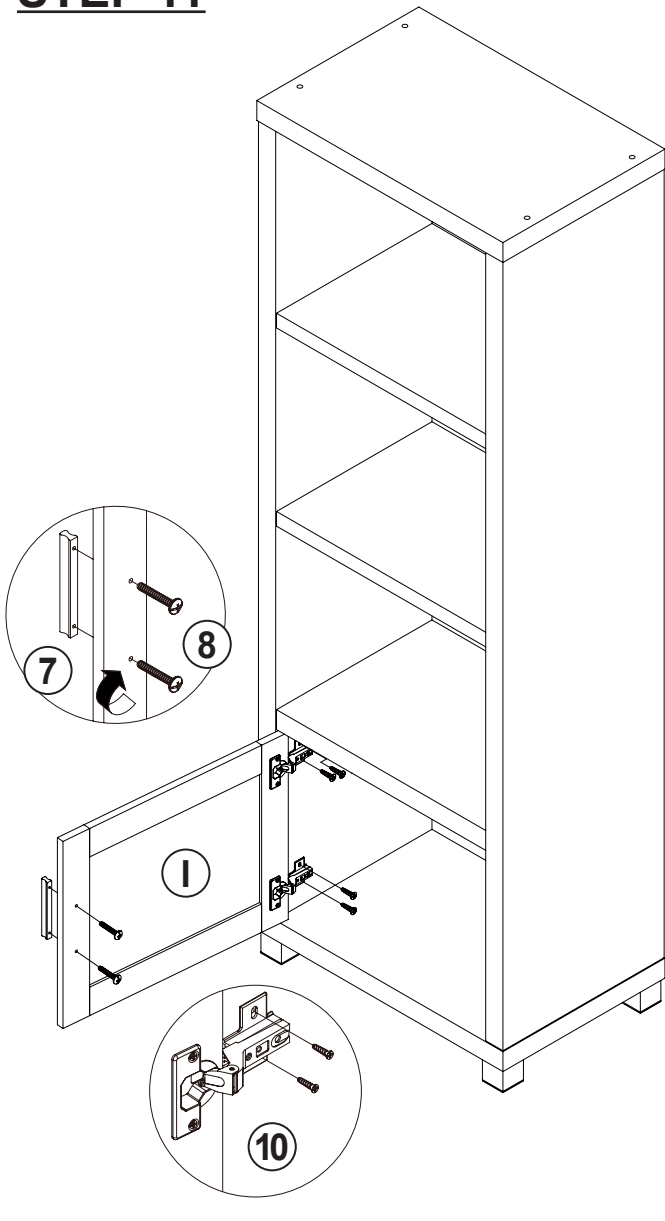
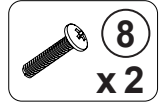
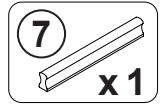

RIGHT

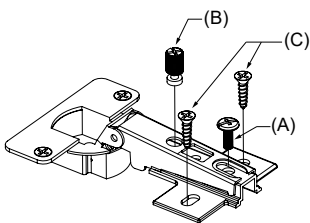
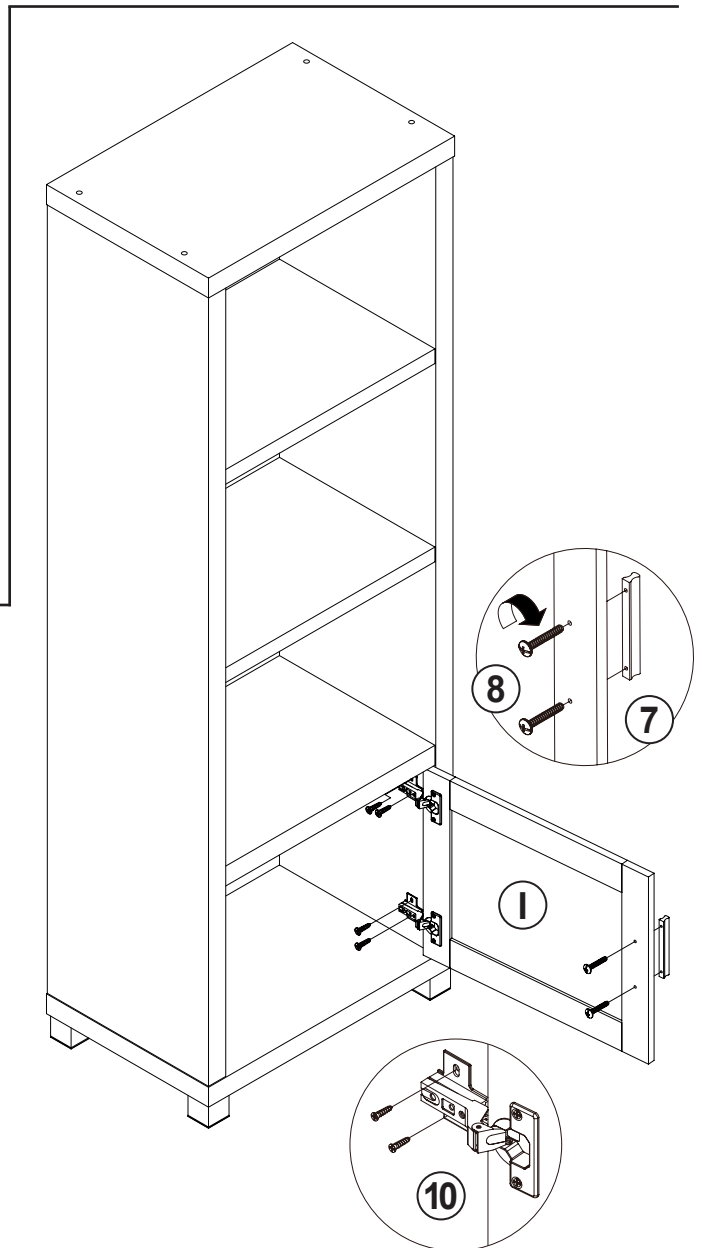

HORIZONTAL BY  
SCREW A ADJUSTMENT

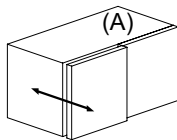

LATERAL BY  
SCREW B ADJUSTMENT

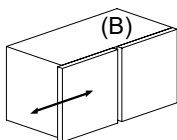

VERTICAL BY  
SCREW C ADJUSTMENT

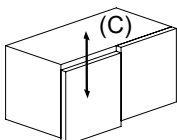

## STEP 12

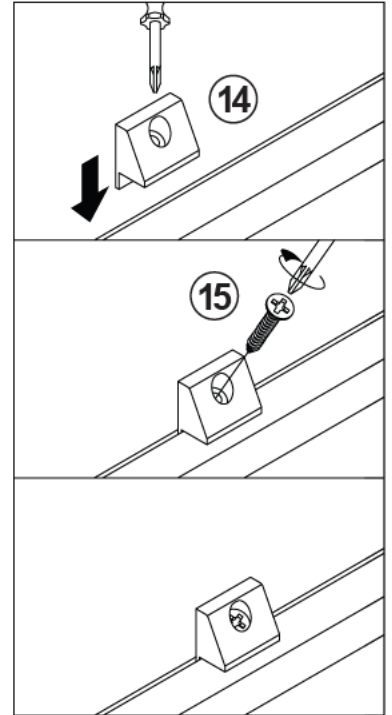
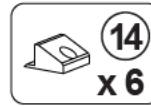
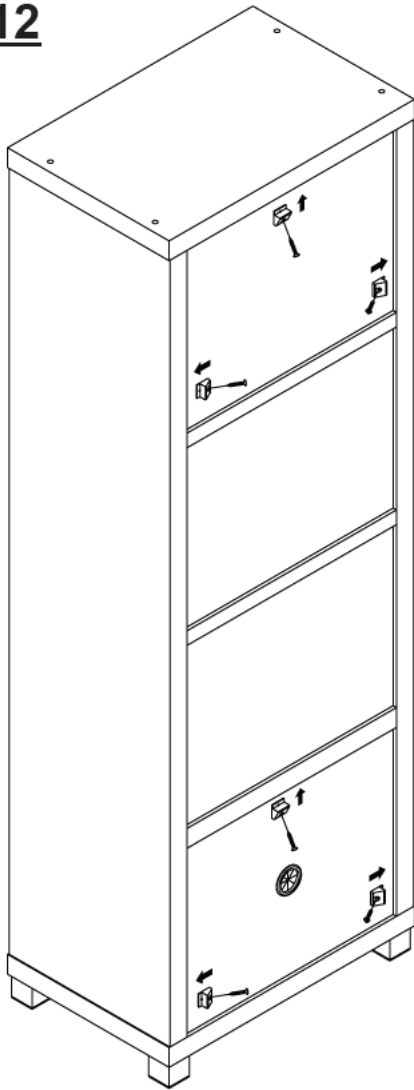

## STEP 13

**COMPLETE**

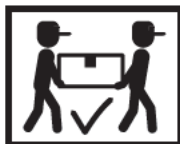
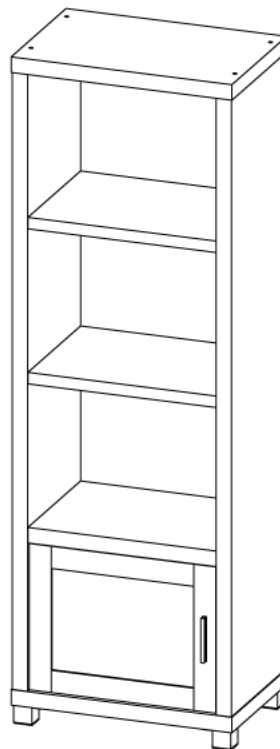



# ANTI-TIPPING INSTALLMENT INSTRUCTIONS

## FURNITURE TIPPING RESTRAINT

### WARNING

Injury may result from tipping furniture.  
This restraint may protect against tipping furniture.  
Do not allow children to climb on furniture.  
This restraint is not a substitute for proper adult supervision.  
Failure to detach this restraint before moving the furniture may result in injury and damage.

This restraint must be screwed to a wood stud on the wall, using the long screw provided.

### STEP 1

Secure the bracket to the back top of the unit, using the short screw provided, as shown in the drawing.

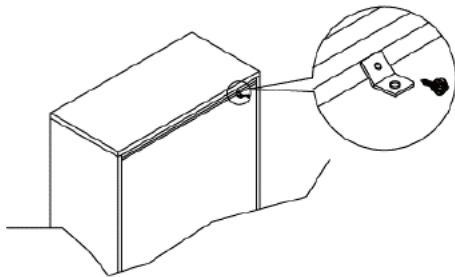

### STEP 2

Locate the wood stud on the wall, and secure the other bracket, 2 inches below the back of the unit.

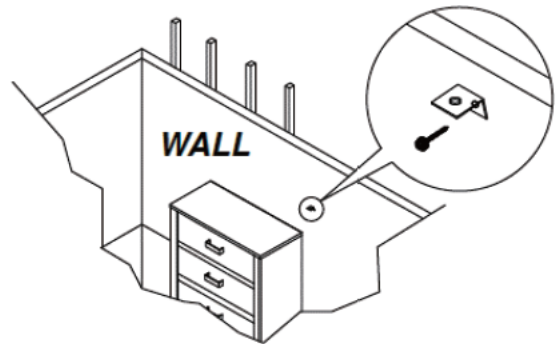

### STEP 3

Place the furniture into position so both mounting brackets are vertically in line. Lace the end of the restraint strap through the larger hole in each mounting bracket. Bring both ends together and slide the flat end through the locking end, and drag it through, until the slack is removed. Ensure that the strap is securely laced and locked.

