

ASSEMBLY INSTRUCTION

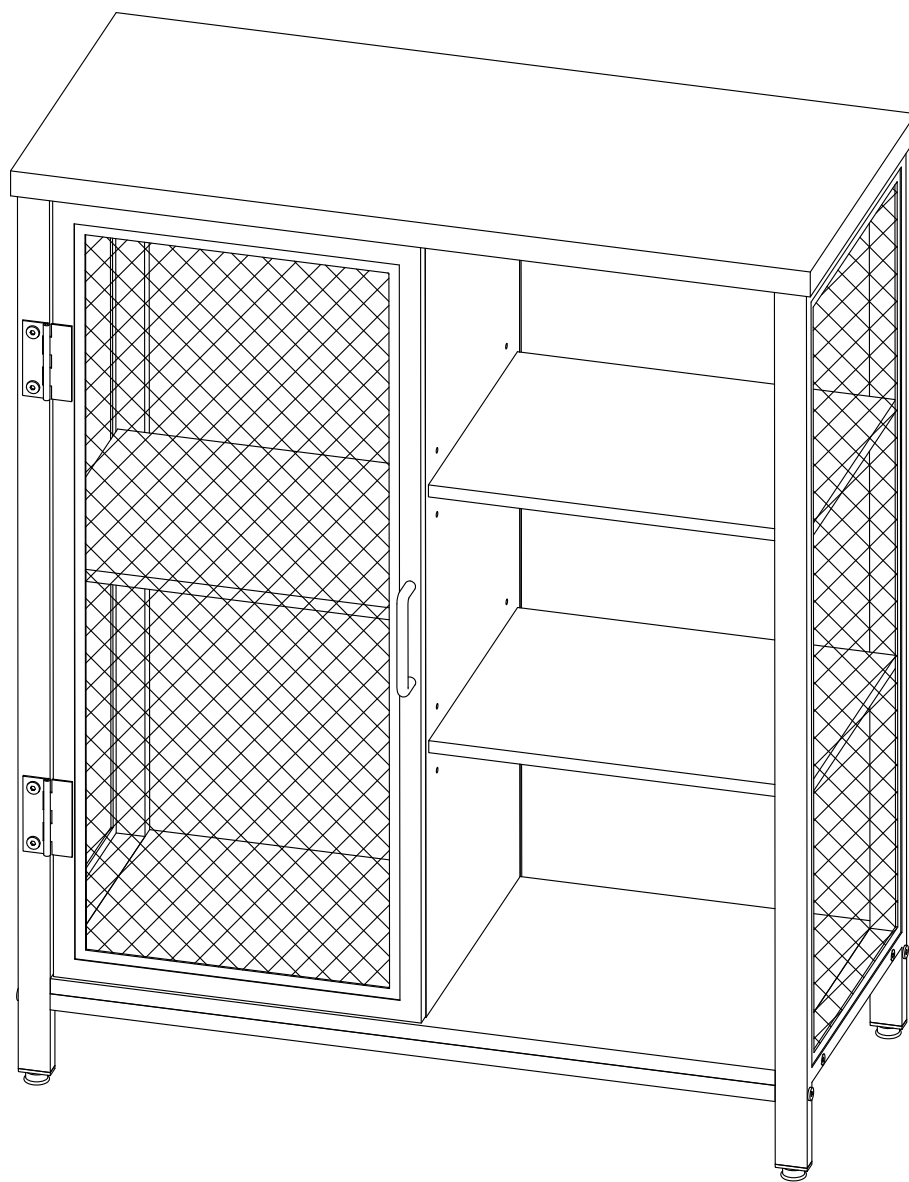

Storage Cabinet

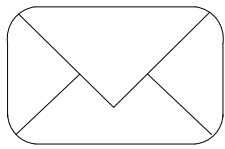

Thank you for purchasing our product. If any parts missed or damaged, please do not hesitate to contact with us, we will send you the replacement parts immediately.

ASSEMBLY TIPS, IT IS AS EASY AS 1,2,3

1. Please read the assembly instructions first and become familiar with the parts.
2. Proper assembly of this item requires 2 people.

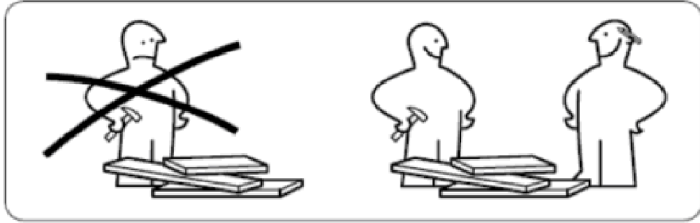

3. Unpack and assemble this unit in an spacious area, assemble the unit on top of the empty carton or carpet to prevent scratches.

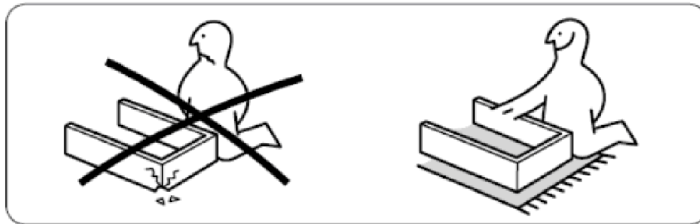

4. To avoid accidentally discarding small parts or hardware, **DO NOT** dispose of any contents until assembly is completed.
5. **Do not fully tighten all bolts until all parts are in place.** Failure to follow these instructions may cause the bolts to misalign during assembly.
6. Taking out the hardware as you need it so you don't get the screws mixed up.



CARE INSTRUCTIONS

- (1) Hardware may loosen overtime. Periodically check that all connections are tight.
- (2) Wipe with a soft, dry cloth. To protect finish, avoid the use of chemicals and household cleaners.
- (3) All hot serving dishes should be placed on a pad.
- (4) Any liquid spilled onto the furniture should be cleaned up immediately with a dry cloth.

Part Identification

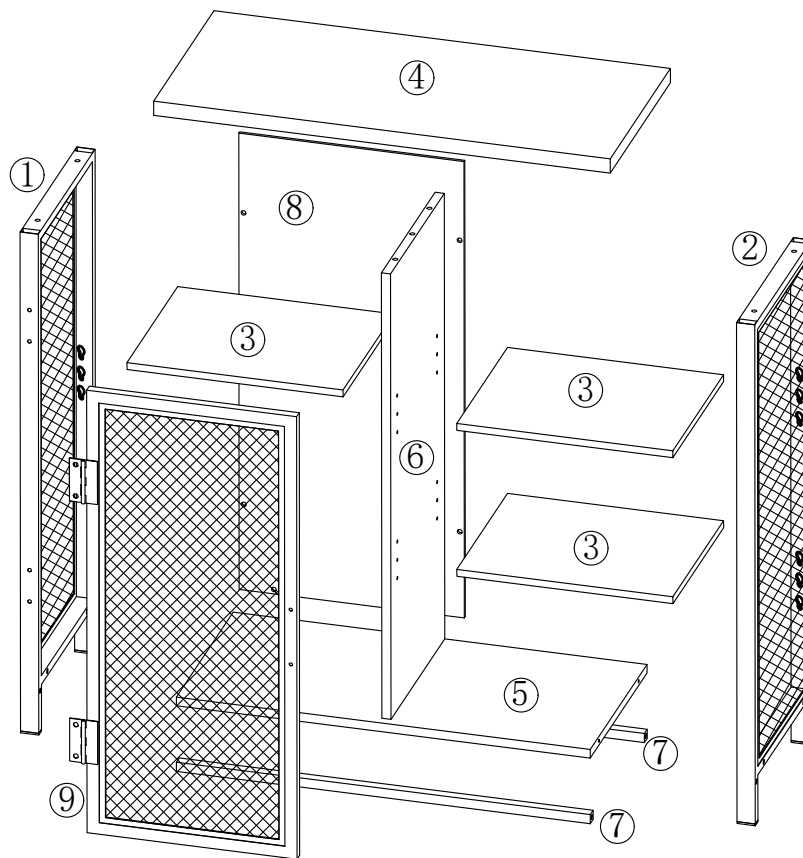

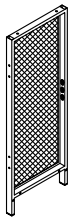
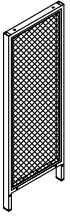
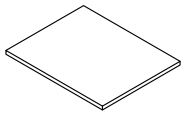
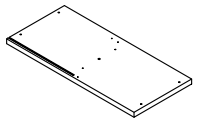
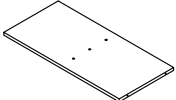
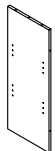

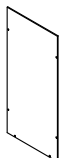
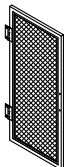





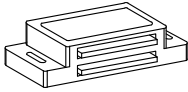
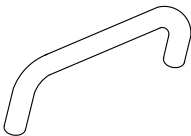
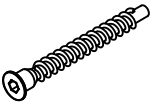
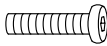

While not parts are labeled, some of the parts will have a label on the edge to help distinguish similar parts from each other. Use this part identification to help identify similar parts.

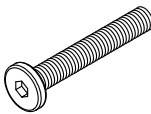
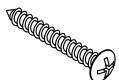
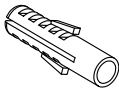
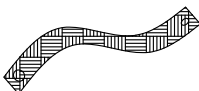

			
<p>Left Leg Frame 1 pc</p>	<p>Right Leg Frame 1 pc</p>	<p>355*286*12 mm Shelf 3 pcs</p>	<p>750*340*25 mm Table Top 1 pc</p>
			
<p>680*320*15 mm Bottom Shelf 1 pc</p>	<p>781*303*15 mm Upright 1 pc</p>	<p>Support tube 2 pcs</p>	<p>800*370*5 mm Back Panel 1 pc</p>
			
<p>Mesh door 1 pc</p>			

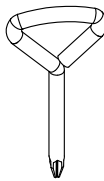
Hardware List

🔧 We've provided extra hardware bag for your replacement in case hardware missing during transportation or assembling.

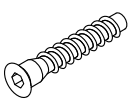
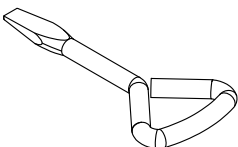
<p>A</p> 	<p>B</p> 	<p>C</p> 	<p>D</p> 	
<p>Adjust Levelers 4 pcs</p>	<p>Shelf Support Pin 6 pcs</p>	<p>Wood Dowel 2 pcs</p>	<p>Magnetic Catch 1 pc</p>	
<p>E</p> 	<p>F</p> 	<p>G</p> 	<p>H</p> 	
<p>Handle Bar 1 pc</p>	<p>Long Hex Head Self Tapping Screw 4 pcs</p>	<p>Allen Bolt 4 pcs</p>	<p>Short Allen Bolt 10 pcs</p>	
<p>I</p> 	<p>J</p> 	<p>K</p> 	<p>L</p> 	
<p>M4*22 mm Machine Screw 2 pcs</p>	<p>Ø3*16 mm Short Self-Tapping Screw 3 pcs</p>	<p>M6*50 mm Long Allen Bolt 4 pcs</p>	<p>Ø4*30 mm Long Self-Tapping Screw 1 pc</p>	
<p>M</p> 	<p>N</p> 	<p>O</p> 	<p>P</p> 	
<p>Ø8*40 mm Plastic Anchor 1 pc</p>	<p>Anti-Tip Strap 1 pc</p>	<p>Allen Key 1 pc</p>	<p>Cross Head Screwdriver 1 pc</p>	
<p>Q</p> 	<p>R</p> 	<p>S</p> 	<p>T</p> 	<p>U</p> 
<p>Ø6*35 mm Cam Screw 2 pcs</p>	<p>Ø15*12 mm Hidden Cam 2 pcs</p>	<p>Shelf Pin 6 pcs</p>	<p>Hex Head Self Tapping Screw 2 pcs</p>	<p>Flat Head Screwdriver 1 pc</p>

Hardware Usage Guide

🔧 HOW TO USE A HIDDEN CAM & CAM SCREW

1. Clockwise rotate the CAM SCREW until the shoulder is against the surface of the board.

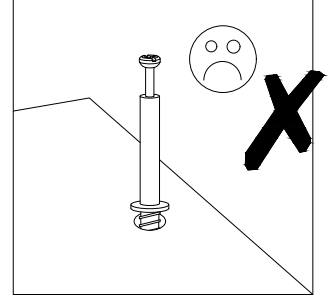
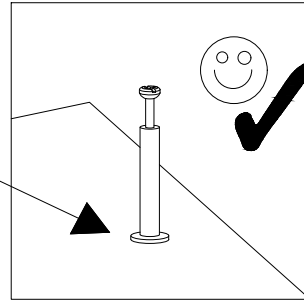
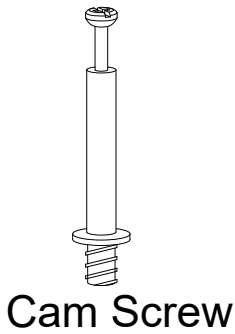

- 2.

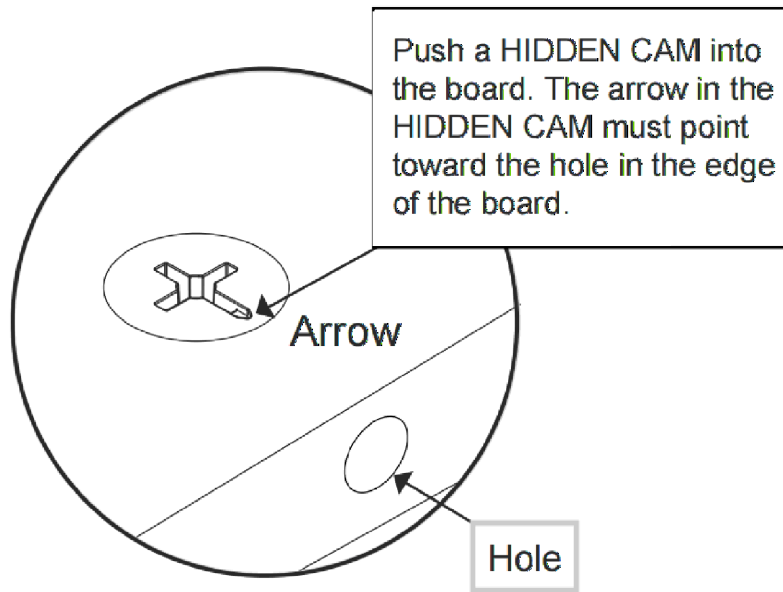
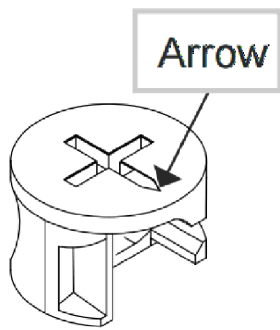

3. Insert the CAM SCREW into the HIDDEN CAM. Clockwise rotate to tighten the HIDDEN CAM.

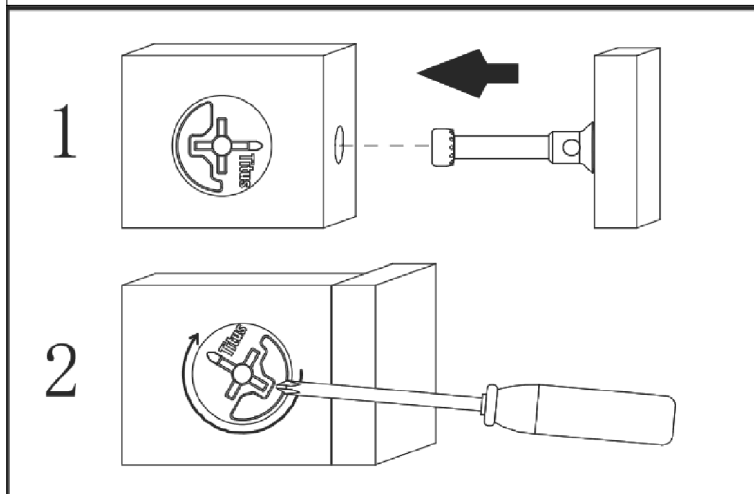

Step 1

Important Note: To avoid incorrect assembly, please follow our steps strictly.

🔌 Find 3 pre-drilled location holes on table top (④).

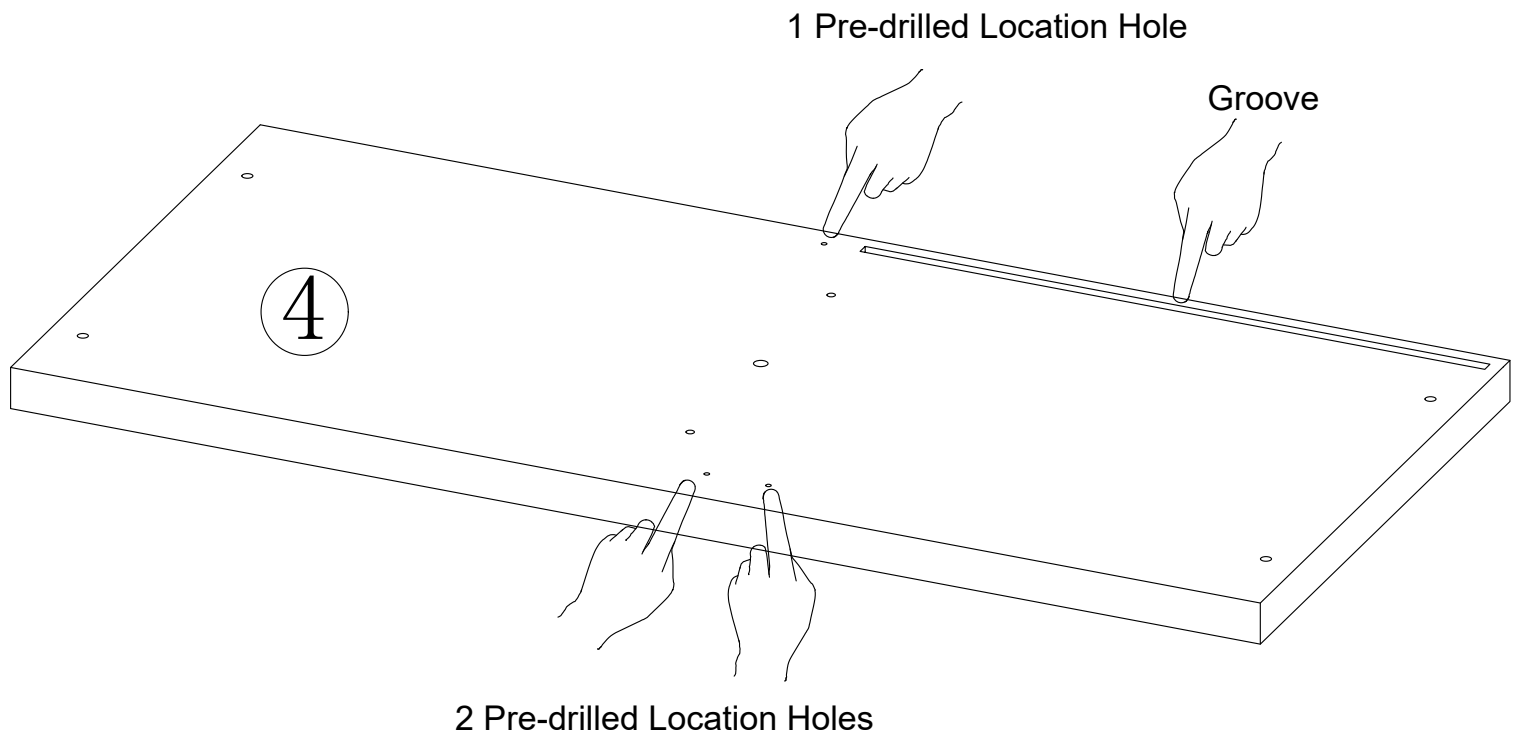

Step 2

Important Note: To avoid incorrect assembly, please follow our steps strictly.

🔌 Fasten 1 pc magnetic catch (D) to 2 pre-drilled location holes of the bottom of table top (④), fully tighten by using 2 pcs short self-tapping screw (J) and cross head screwdriver (P).

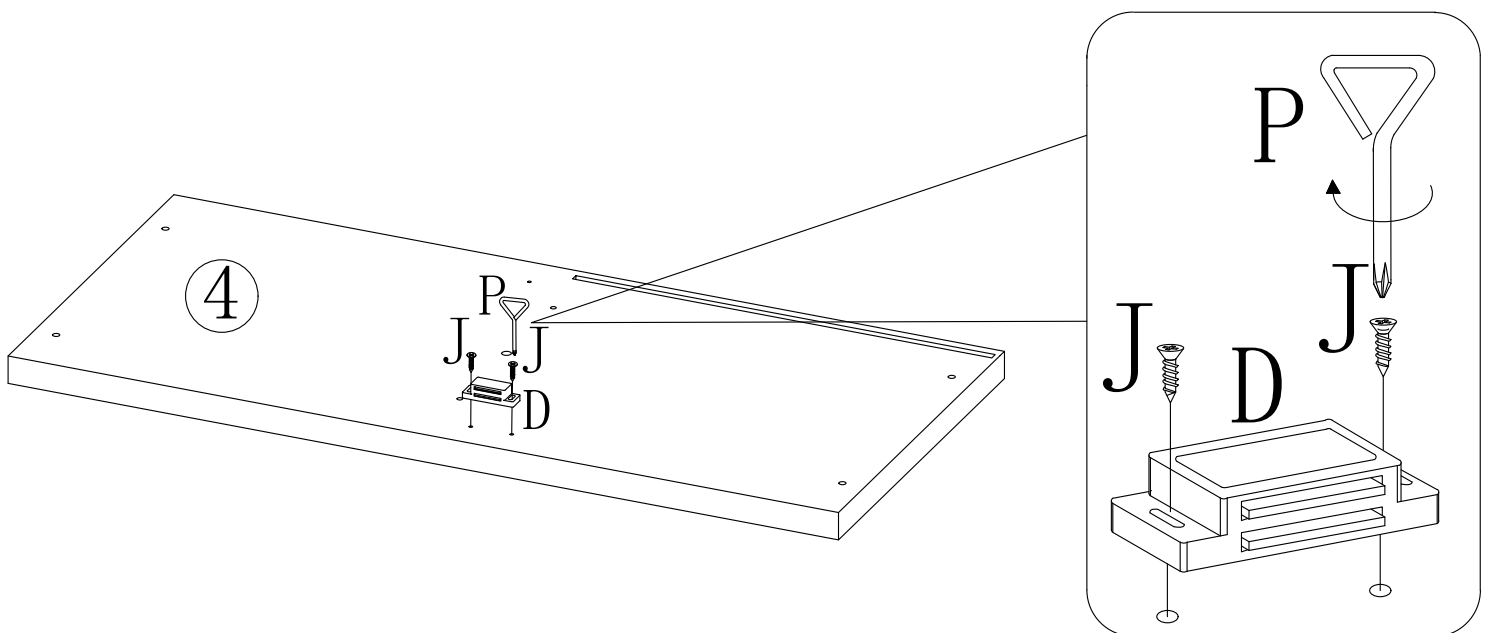

*IMPORTANT NOTE:

-The magnetic should face to front side.

-When you assemble to STEP 24, if you find mesh door (⑨) can not reach the magnetic catch (D) perfectly, you can adjust magnetic catch a little bit forward.

Step 3

Important Note: To avoid incorrect assembly, please follow our steps strictly.

🔧 Attach anti-tip strap (N) to the 1 pre-drilled location hole of the bottom of table top (④), fully tighten by using 1 pc short self-tapping screw (J) and cross head screwdriver (P).

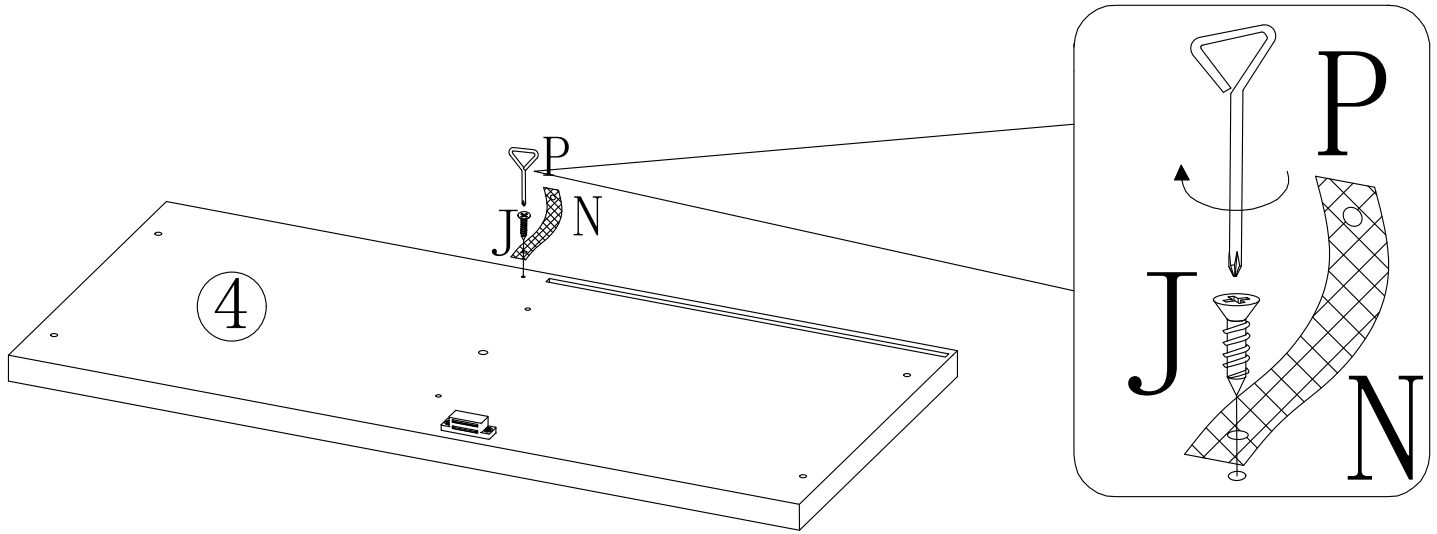

Step 4

Important Note: To avoid incorrect assembly, please follow our steps strictly.

🔧 Fully tighten 2 pcs cam screw (Q) to the bottom of table top (④), fix by using cross head screwdriver (P). Tighten until the shoulder is against the surface of the board.

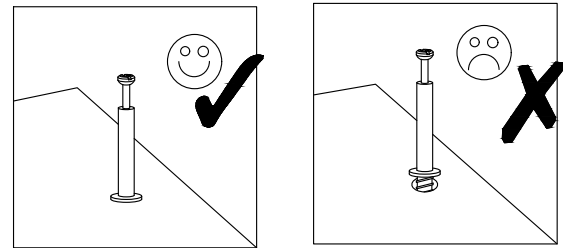
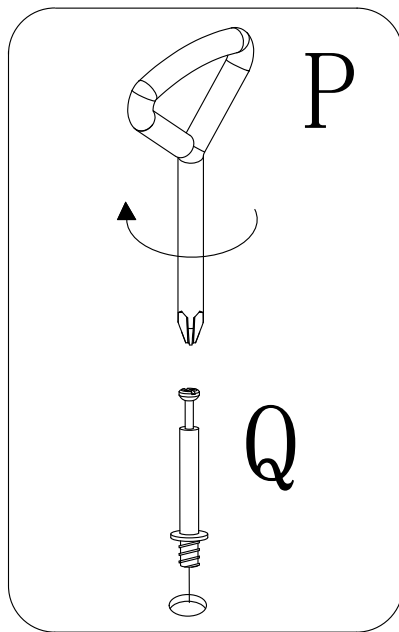

Clockwise rotate the CAM SCREW until the shoulder is against the surface of the board.

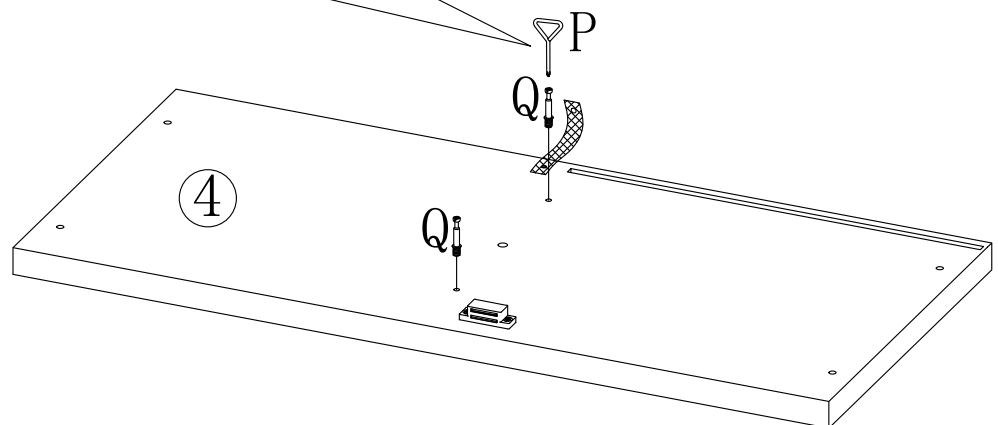

Step 5

Important Note: To avoid incorrect assembly, please follow our steps strictly.

🔌 Insert 1 pc wood dowel (C) to the bottom of table top (④).

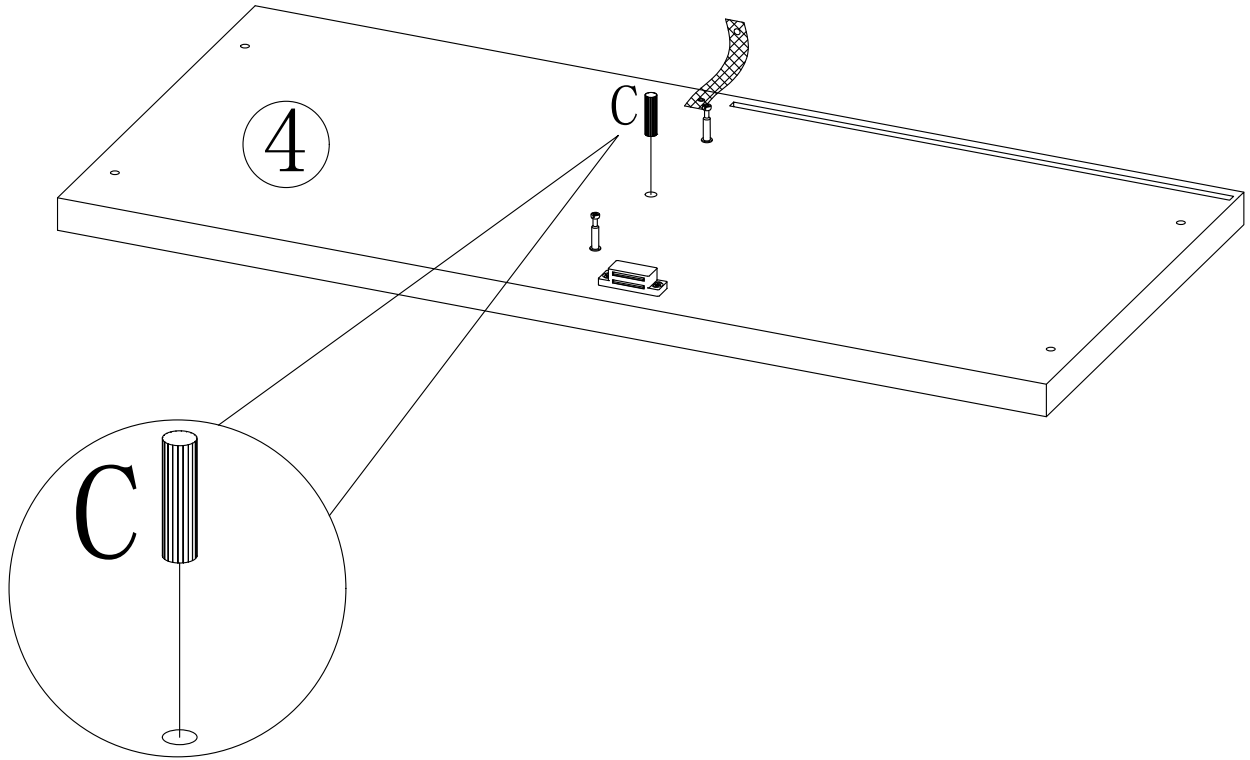

🔌 Flip table top (④) up, make sure the groove is on the top side and magnetic catch on the bottom.

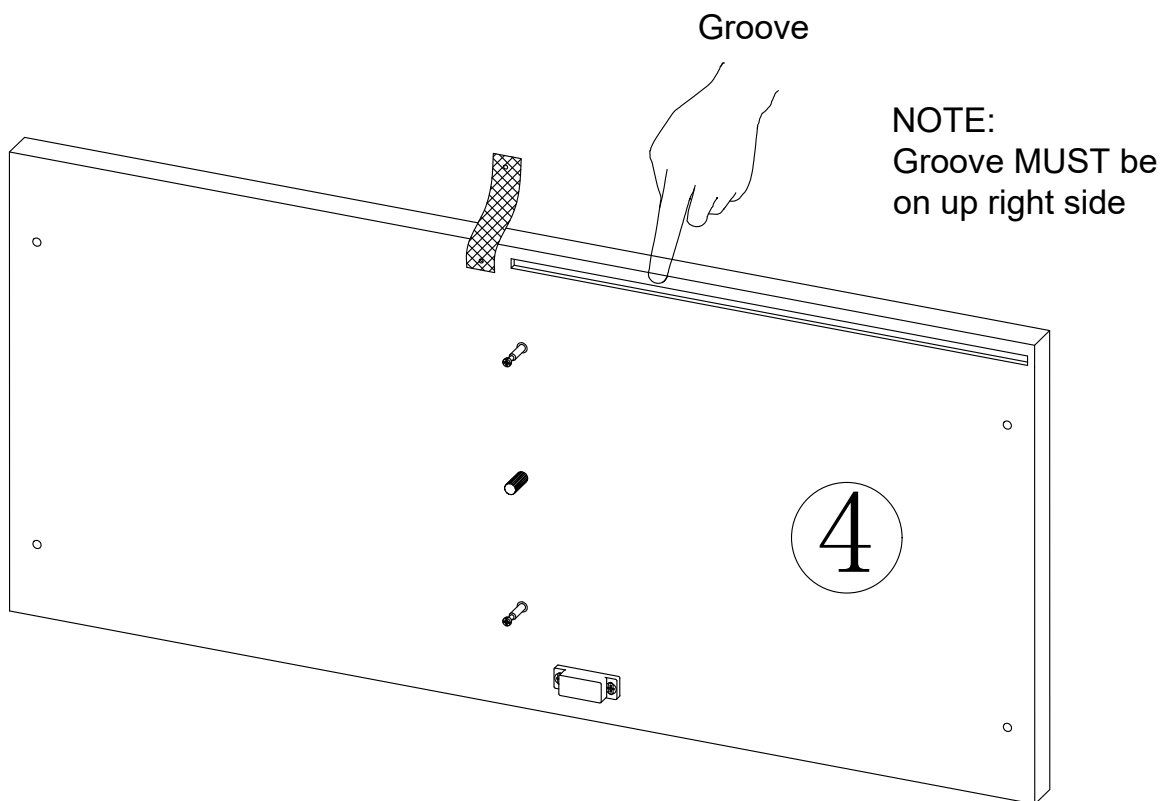

Step 6

Important Note: To avoid incorrect assembly, please follow our steps strictly.

- Flip the upright (⑥) up and make sure the two edge holes on top side. And 6 shelf pin holes and 2 hidden cam holes MUST on RIGHT side. Then insert the upright (⑥) to table top (④).

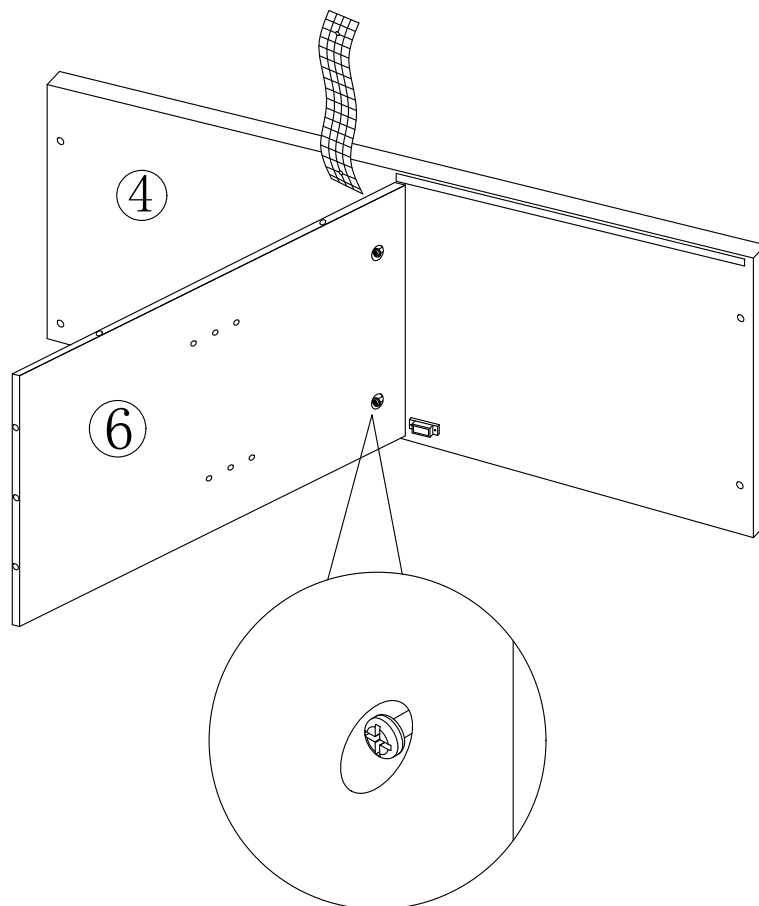
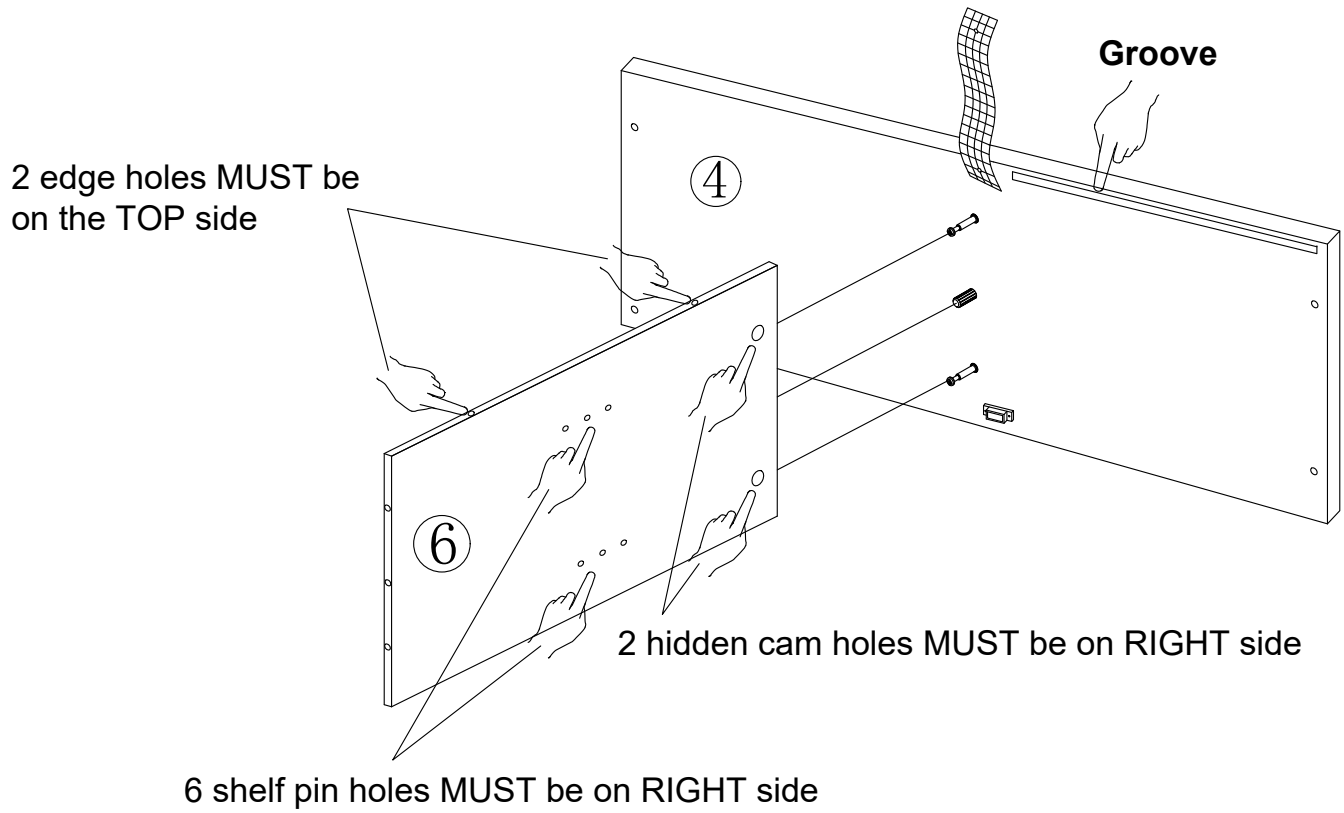

Step 7

Important Note: To avoid incorrect assembly, please follow our steps strictly.

Push 2 pcs hidden cam (R) into upright (⑥). The ARROW in the hidden cam (R) MUST point straight to table top (④). Then tighten hidden cam (R) by using flat head screwdriver (U).

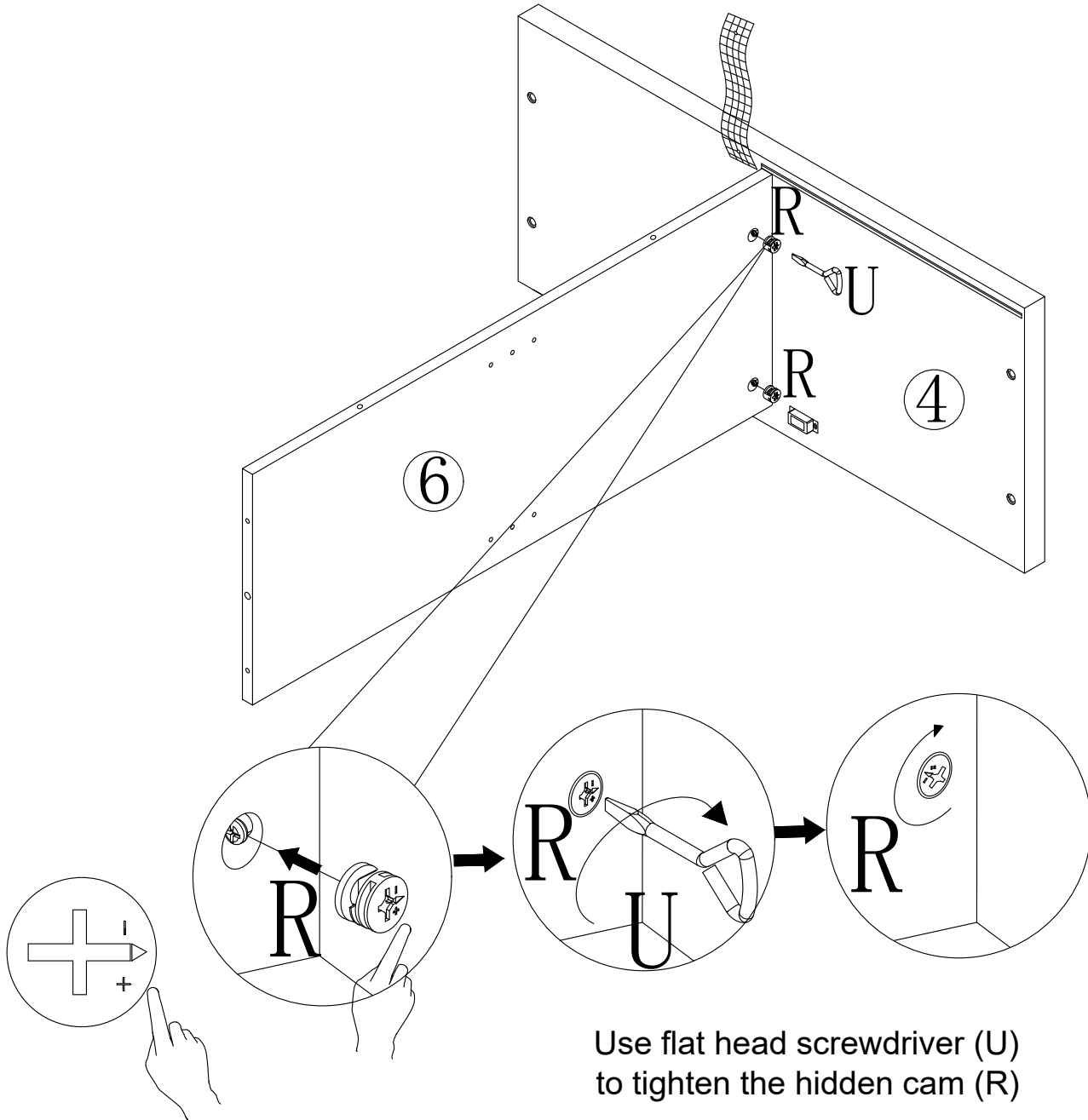

Use flat head screwdriver (U) to tighten the hidden cam (R)

NOTE: The ARROW in the hidden cam (R) MUST point straight to table top (④) before inserting to hidden cam holes.

Step 8

Important Note: To avoid incorrect assembly, please follow our steps strictly.

🔌 Insert 1 pc wood dowel (C) to the bottom of upright (⑥).

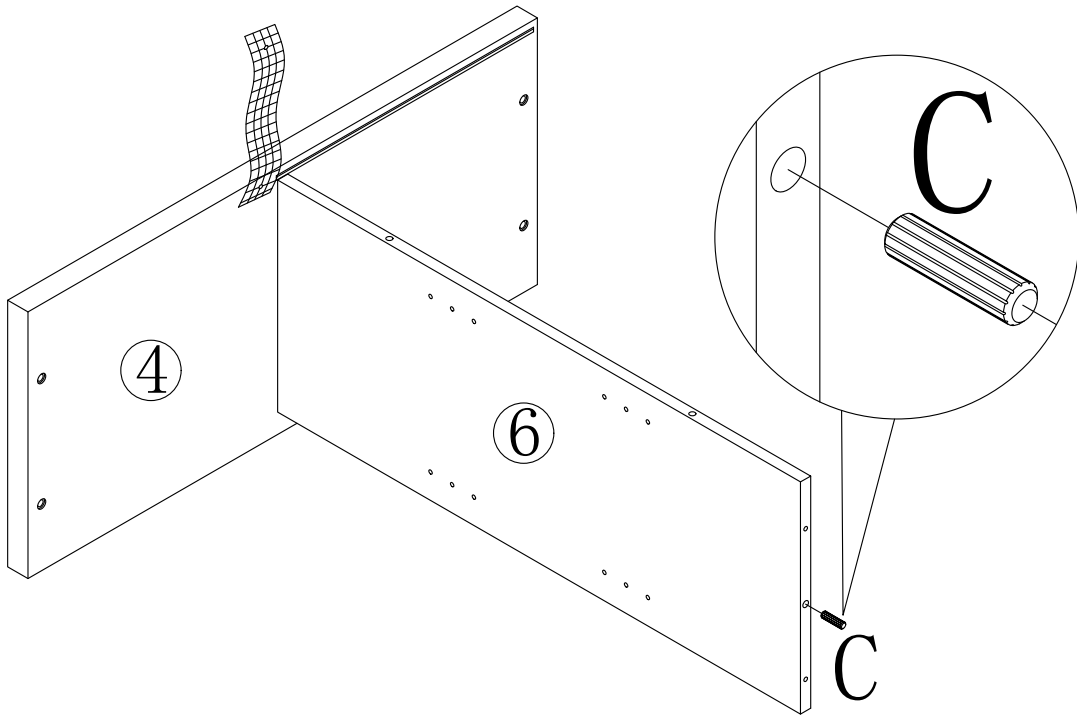

Step 9

Important Note: To avoid incorrect assembly, please follow our steps strictly.

🔌 Attached bottom shelf (⑤) to upright (⑥). Then fix by using 2 pcs hex head self tapping screw (T) and allen key (O). **DO NOT TIGHTEN COMPLETELY.** Stop when you feel you are adding force to tighten the bolt.

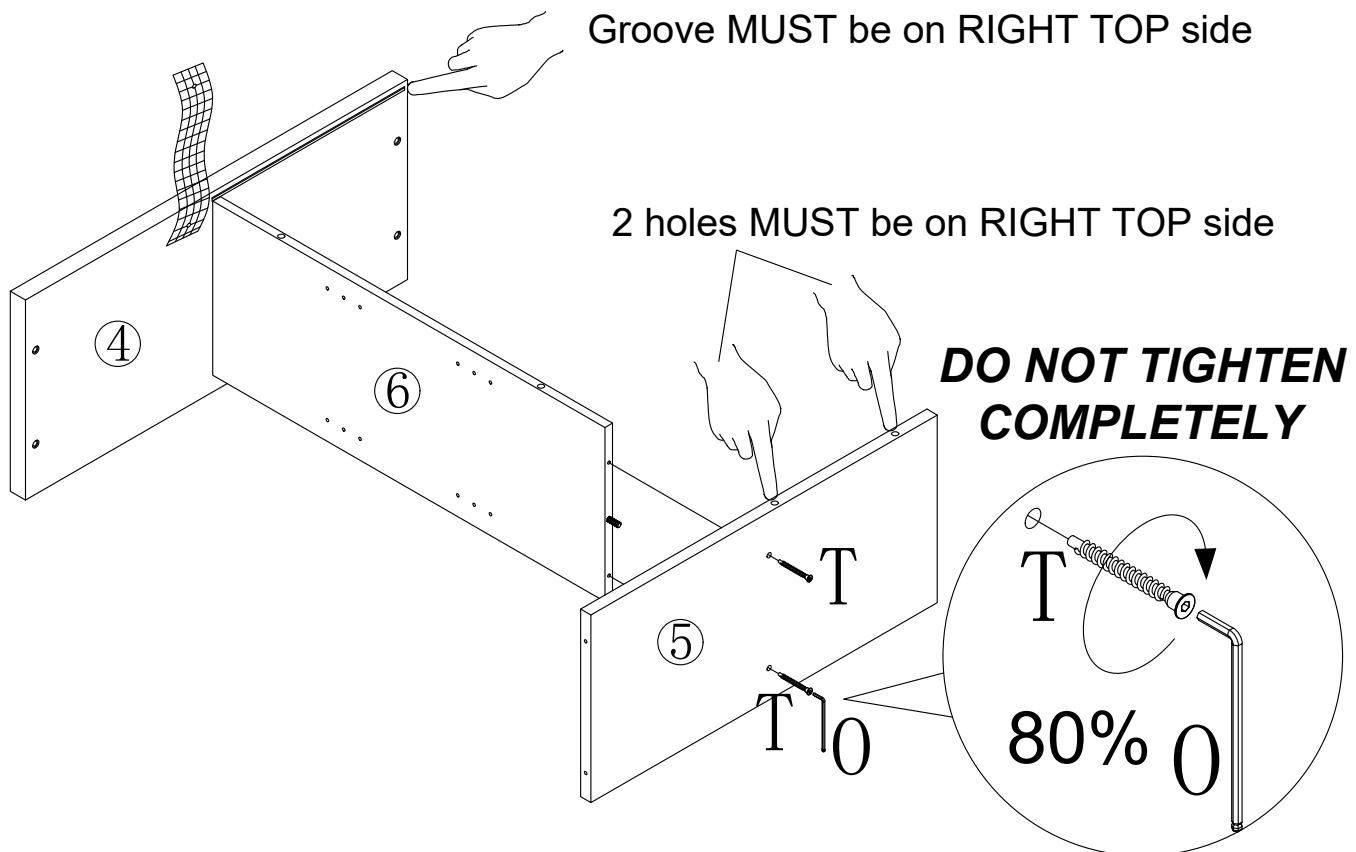

Step 10

Important Note: To avoid incorrect assembly, please follow our steps strictly.

🔌 Distinguish left leg frame (①) and right leg frame (②) first. Left leg frame (①) has 6 holes inward. And right leg frame (②) has 12 holes inward. Below pictures for your reference.

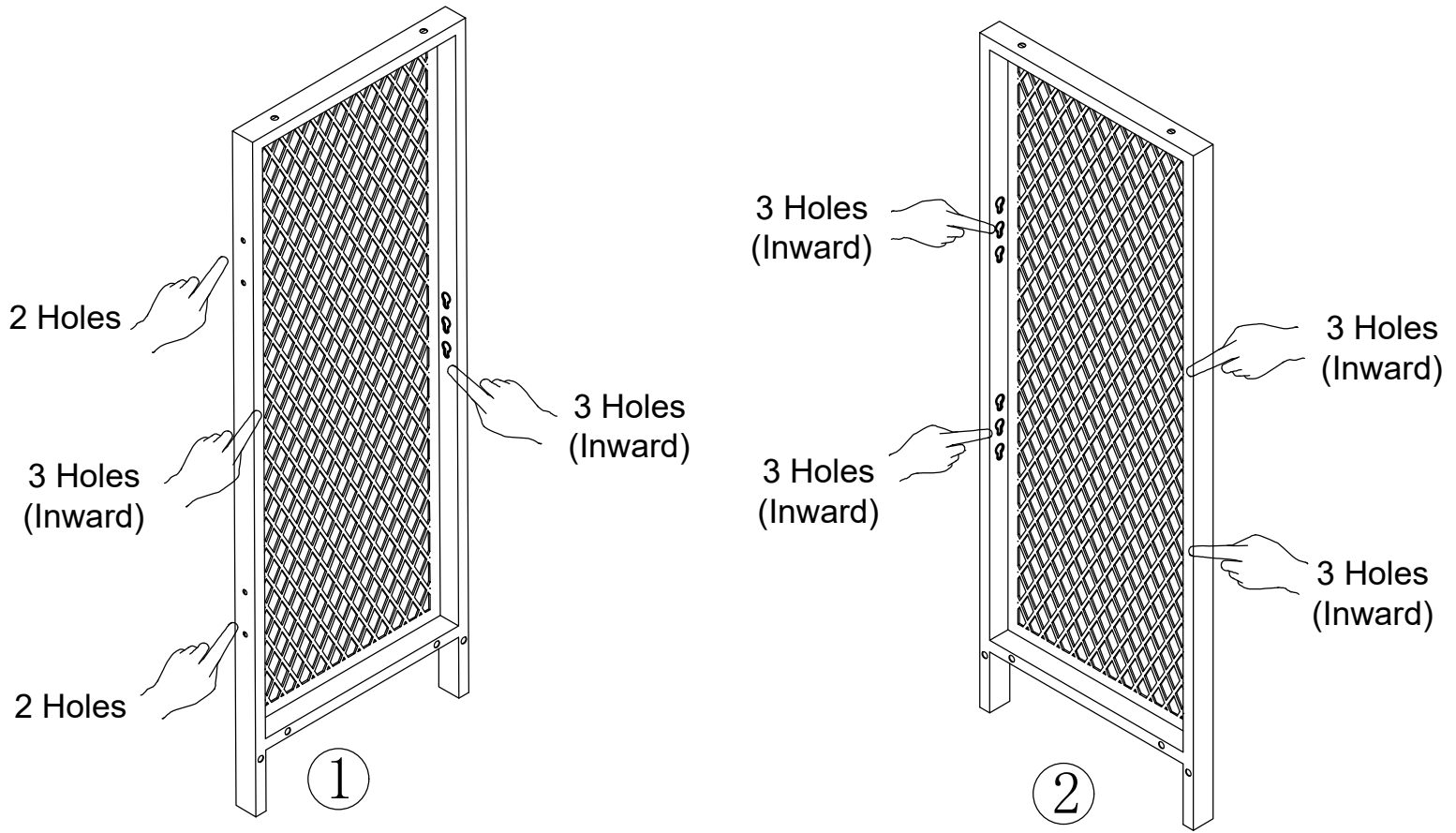

Step 11

Important Note: To avoid incorrect assembly, please follow our steps strictly.

🔌 Attach 4 pcs adjustable leveler (A) to the bottom of the leg frame(①&②).

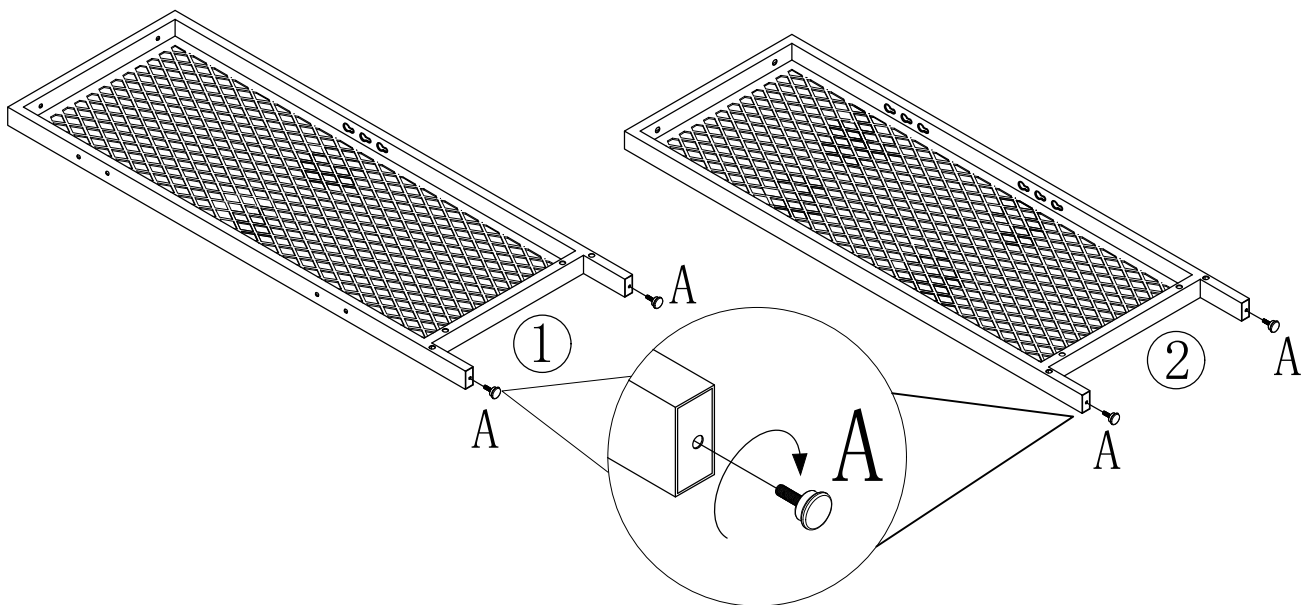

Step 12

Important Note: To avoid incorrect assembly, please follow our steps strictly.

🔧 Attach metal leg frame (②) to the LEFT side of table top (④). Then fix by using 2 pcs allen bolt (G) and allen key (O). DO NOT TIGHTEN COMPLETELY. Stop when you feel you are adding force to tighten the bolt.

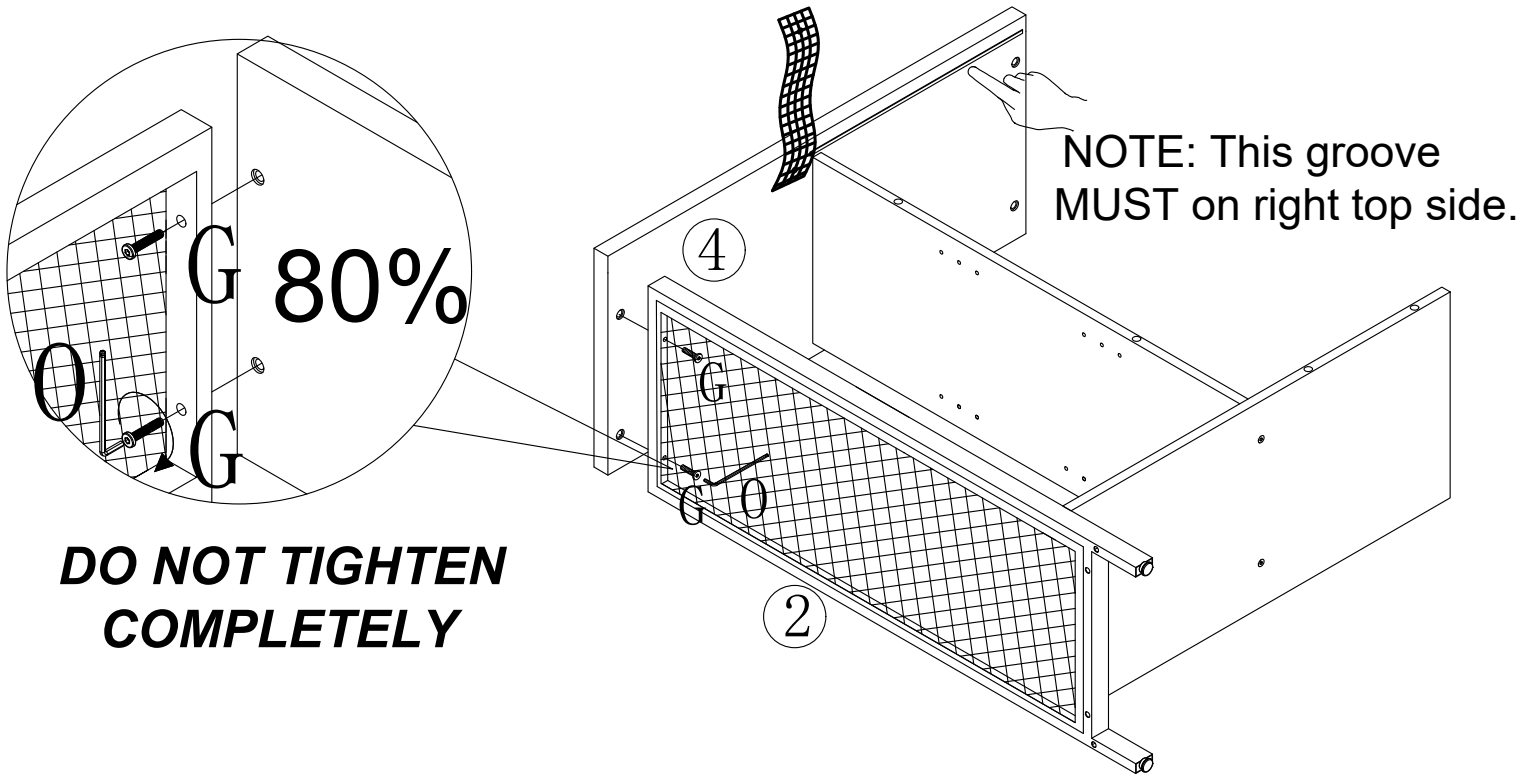

Step 13

Important Note: To avoid incorrect assembly, please follow our steps strictly.

🔧 Attach metal leg frame (②) to bottom shelf (⑤), fix by using 2 pcs long hex head self tapping screw (F) and allen key (O). DO NOT TIGHTEN COMPLETELY. Stop when you feel you are adding force to tighten the bolt.

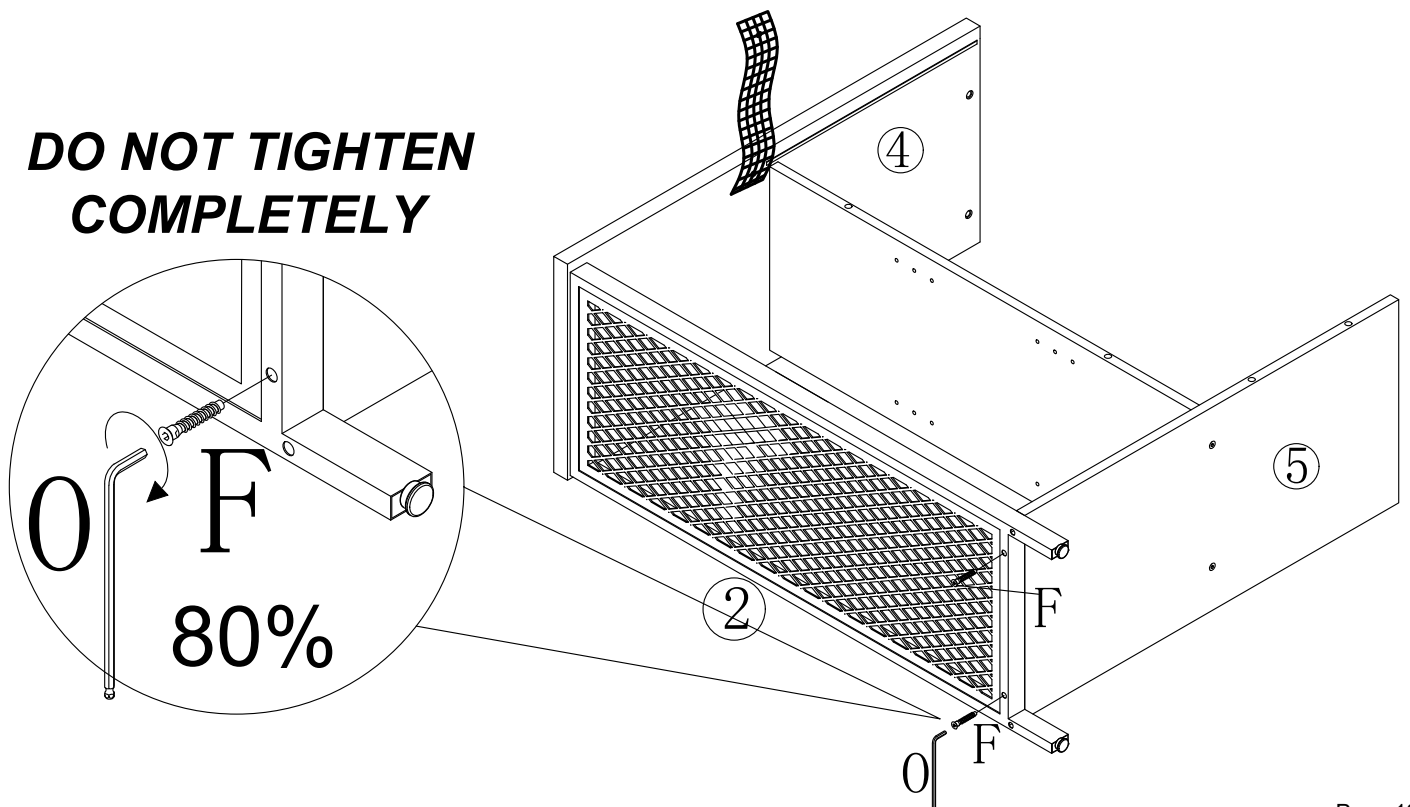

Step 14

Important Note: To avoid incorrect assembly, please follow our steps strictly.

🔧 Attach leg frame (①) to RIGHT side of table top (④), fix by using 2 pcs allen bolt (G) and allen key (O). DO NOT TIGHTEN COMPLETELY. Stop when you feel you are adding force to tighten the bolt.

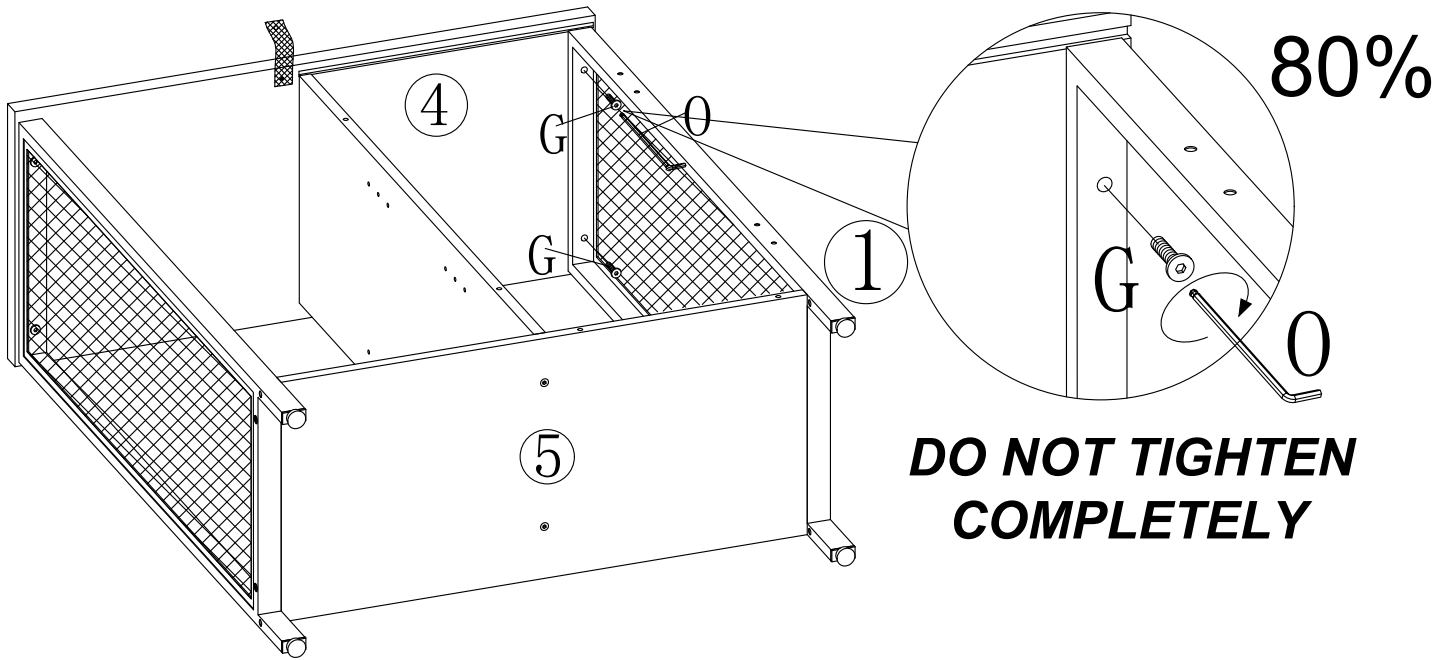

Step 15

Important Note: To avoid incorrect assembly, please follow our steps strictly.

🔧 Attach metal leg frame (①) to bottom shelf (⑤). Fix by using 2 pcs long hex head self tapping screw (F) and allen key (O). DO NOT TIGHTEN COMPLETELY. Stop when you feel you are adding force to tighten the bolt.

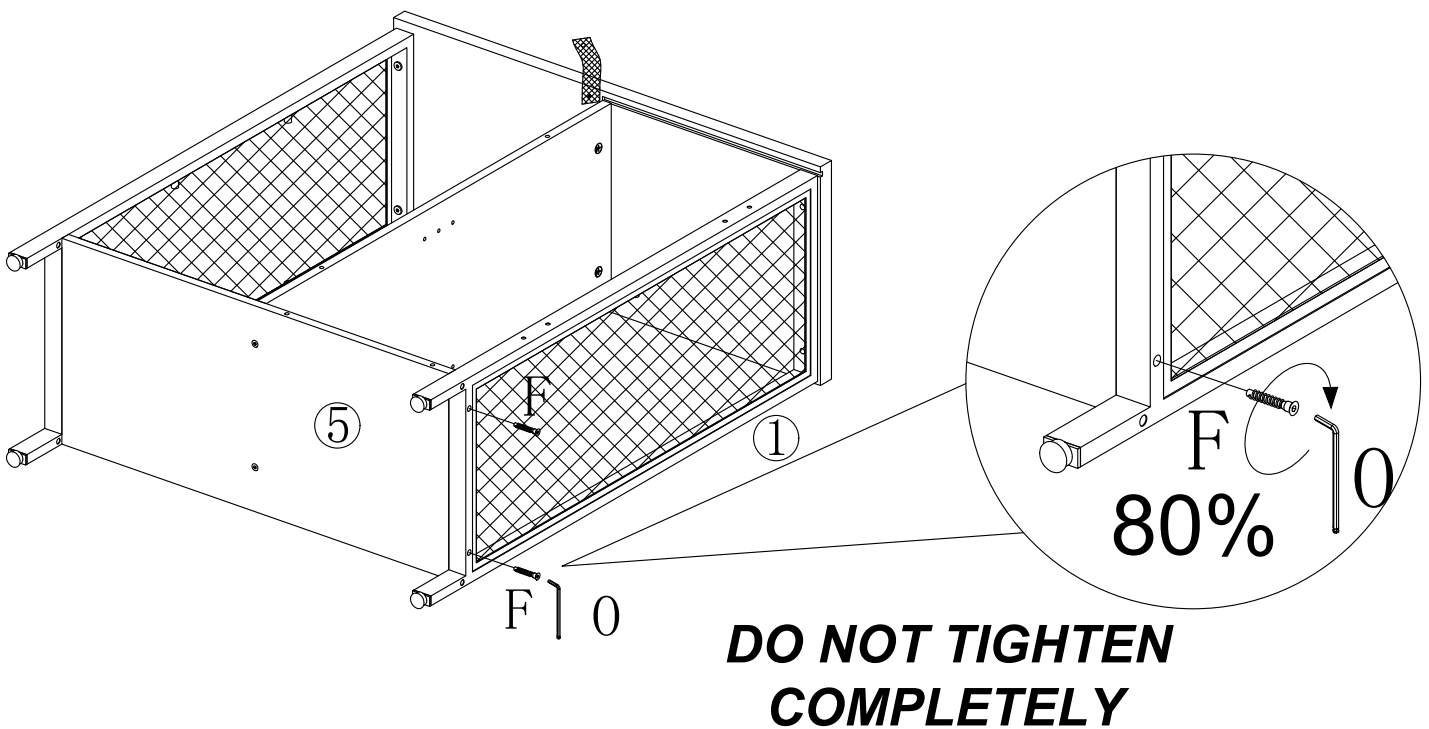

Step 16

Important Note: To avoid incorrect assembly, please follow our steps strictly.

🔌 Insert back panel (8) into the groove of table top (4).

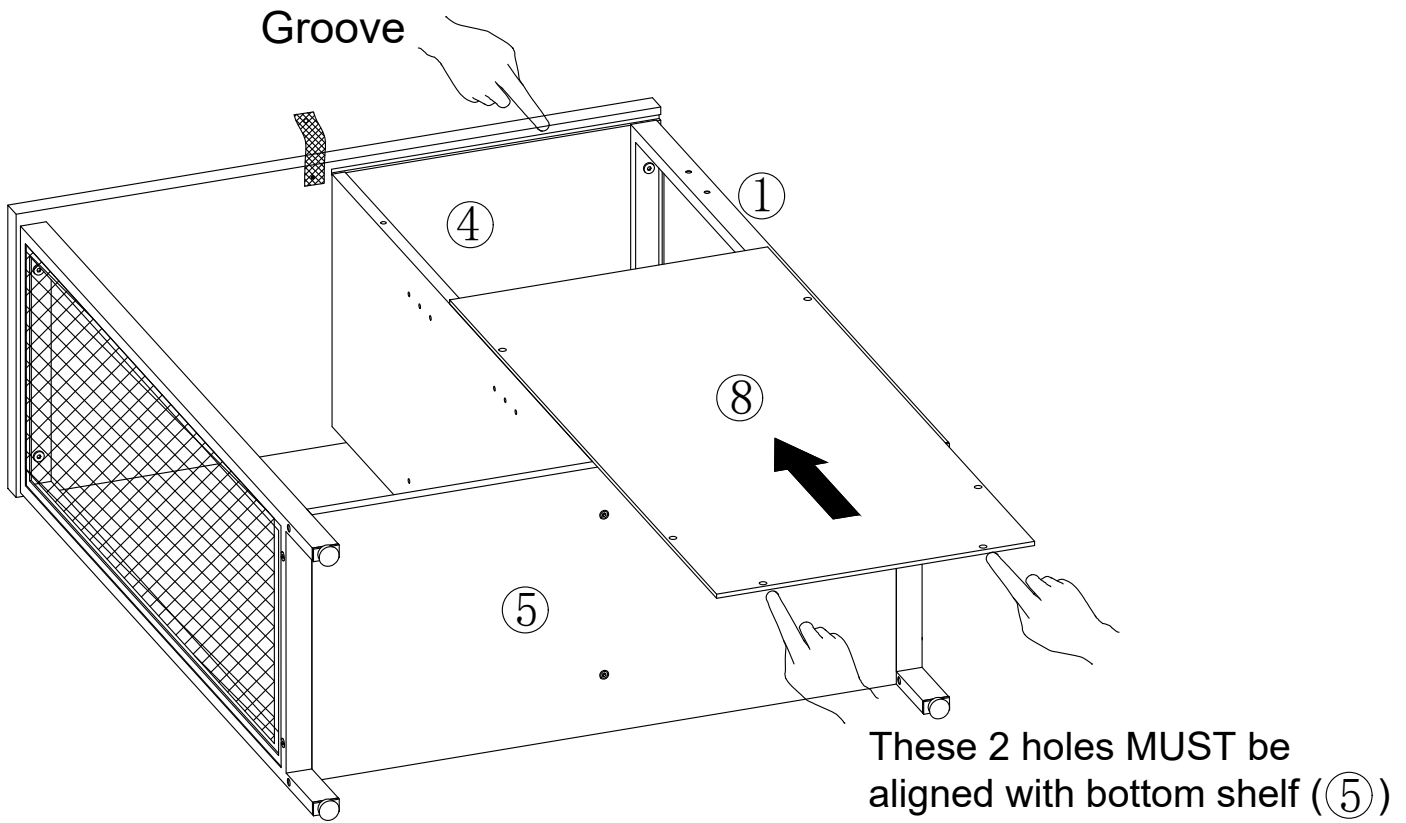

Step 17

Important Note: To avoid incorrect assembly, please follow our steps strictly.

🔌 Fasten back panel (8) to metal leg frame (1) and upright (6), fix by using 6 pcs short allen bolt (H) and allen key (O). DO NOT TIGHTEN COMPLETELY. Stop when you feel you are adding force to tighten the bolt.

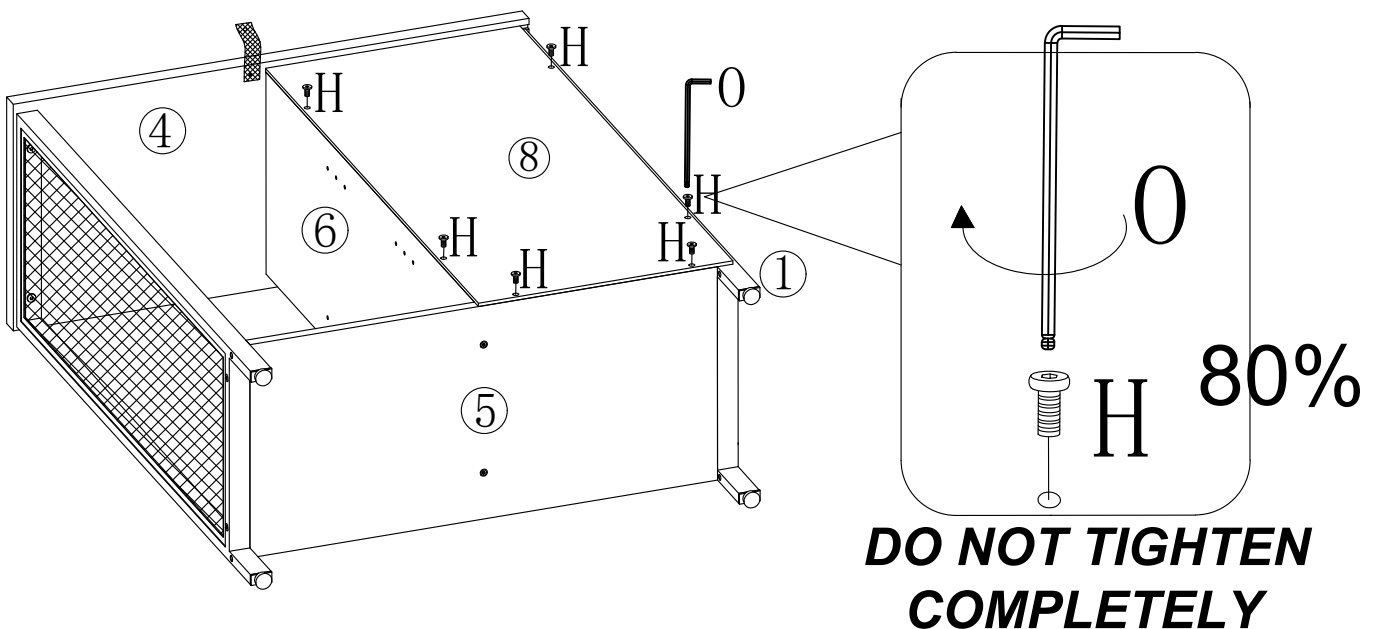

Step 18

Important Note: To avoid incorrect assembly, please follow our steps strictly.

- Make sure 4 pcs assembled long hex head self tapping screws (F) are not fully tightened, and push metal leg frames (①&②) a little bit outwards before attaching the support tubes (⑦). This will avoid unexpected scratches.
- Attach 2 pcs support tube (⑦) to left and right leg frame (①&②), fix by using 4 pcs long allen bolt (K) and allen key (O).

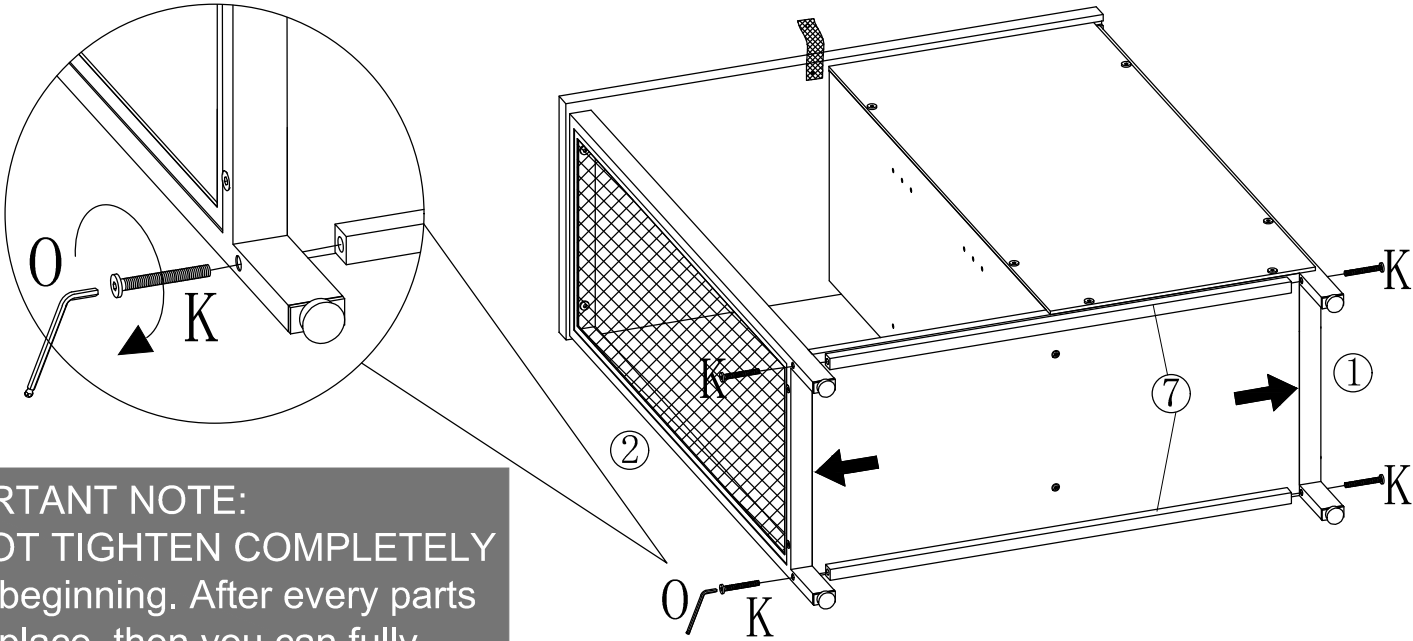

IMPORTANT NOTE:
DO NOT TIGHTEN COMPLETELY at the beginning. After every parts are in place, then you can fully tighten all bolts (F&G&H&K&T).

Step 19

Important Note: To avoid incorrect assembly, please follow our steps strictly.

- After fully tighten all the screws and bolts, flip cabinet up. If you find the cabinet wobbles like below, you can loose 6 pcs bolt (H) of back panel (⑧). And press on the table top with a little bit force to make 4 legs in the same level. Then fully tighten 6 pcs bolt (H) again.

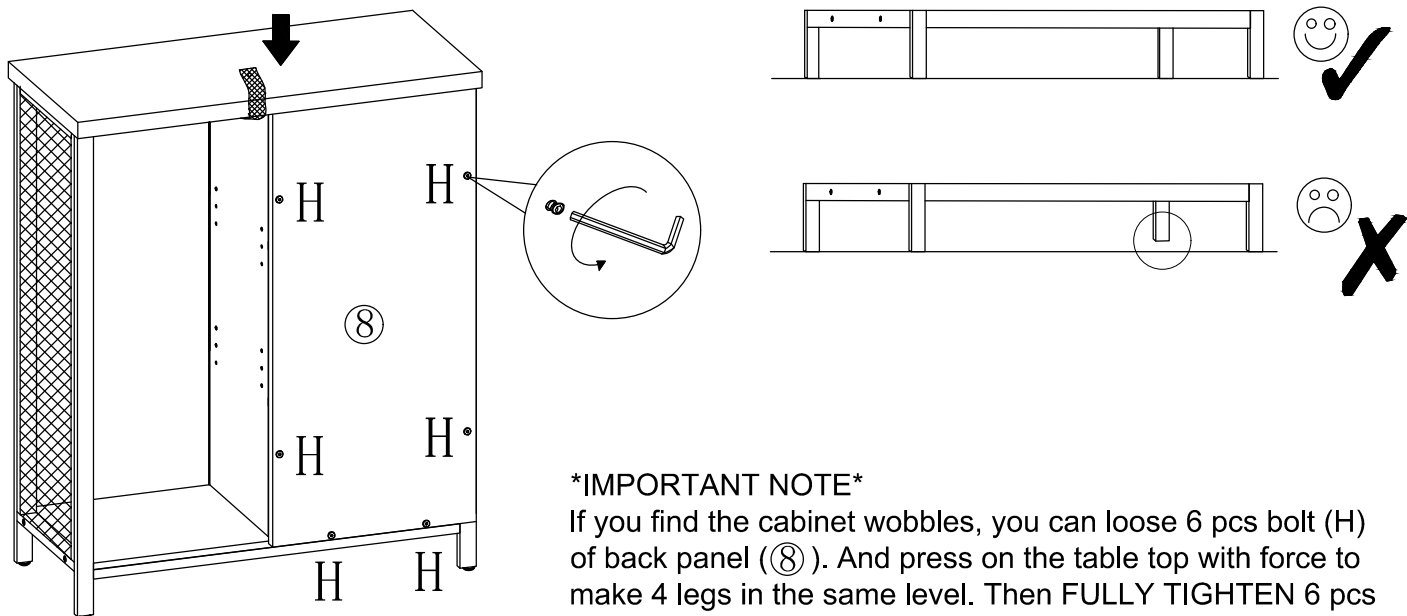

IMPORTANT NOTE

If you find the cabinet wobbles, you can loose 6 pcs bolt (H) of back panel (⑧). And press on the table top with force to make 4 legs in the same level. Then FULLY TIGHTEN 6 pcs bolt (H) again.

Step 20

Important Note: To avoid incorrect assembly, please follow our steps strictly.

🔌 Insert 6 pcs shelf pin (S) into upright (⑥).

NOTE: We have drilled extra holes, so that you can adjust shelf height as you want.

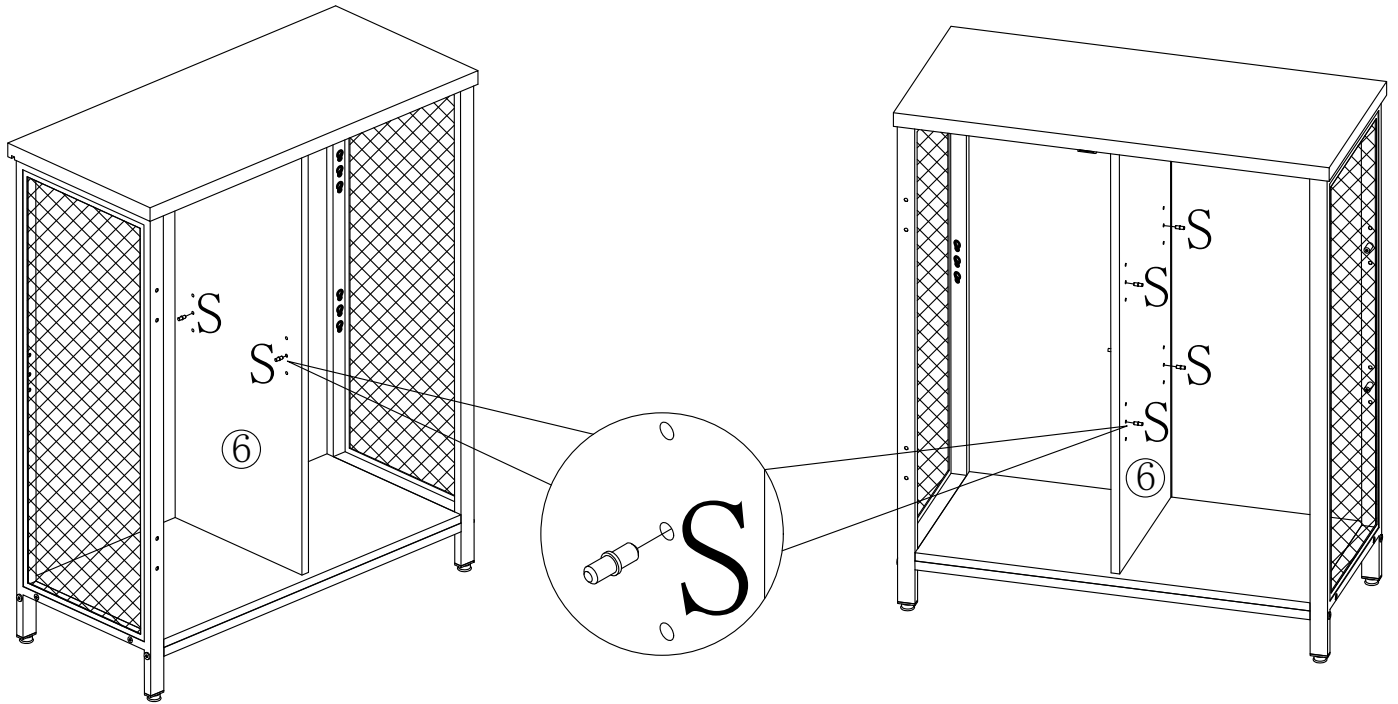

Step 21

Important Note: To avoid incorrect assembly, please follow our steps strictly.

🔌 Insert the 6 pcs shelf support pin (B) to the middle hole of leg frame (① & ②).

NOTE: We have drilled extra holes, so that you can adjust shelf height as you want.

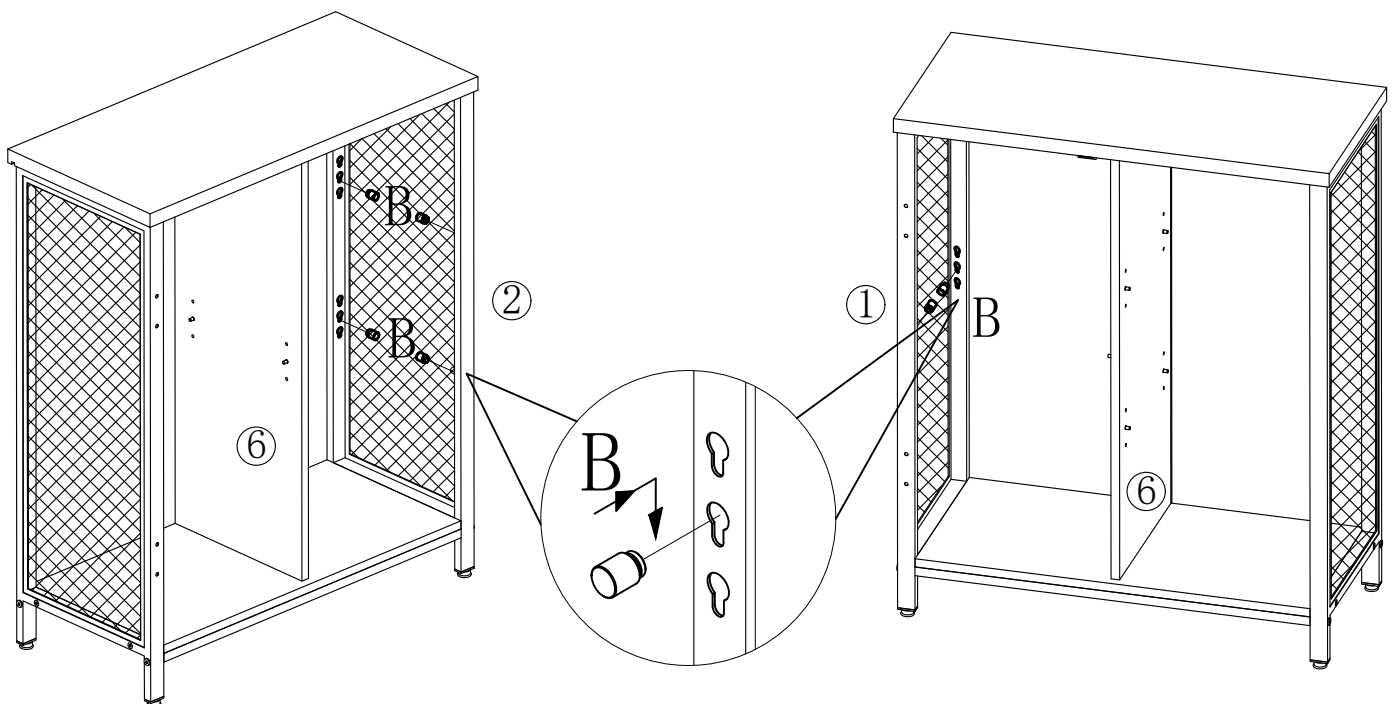

Step 22

Important Note: To avoid incorrect assembly, please follow our steps strictly

🔌 Attach 1 pc handle bar (E) to 1 pc mesh door (⑨), fully tighten by using 2 pcs machine screw (I) and cross head screwdriver (P).

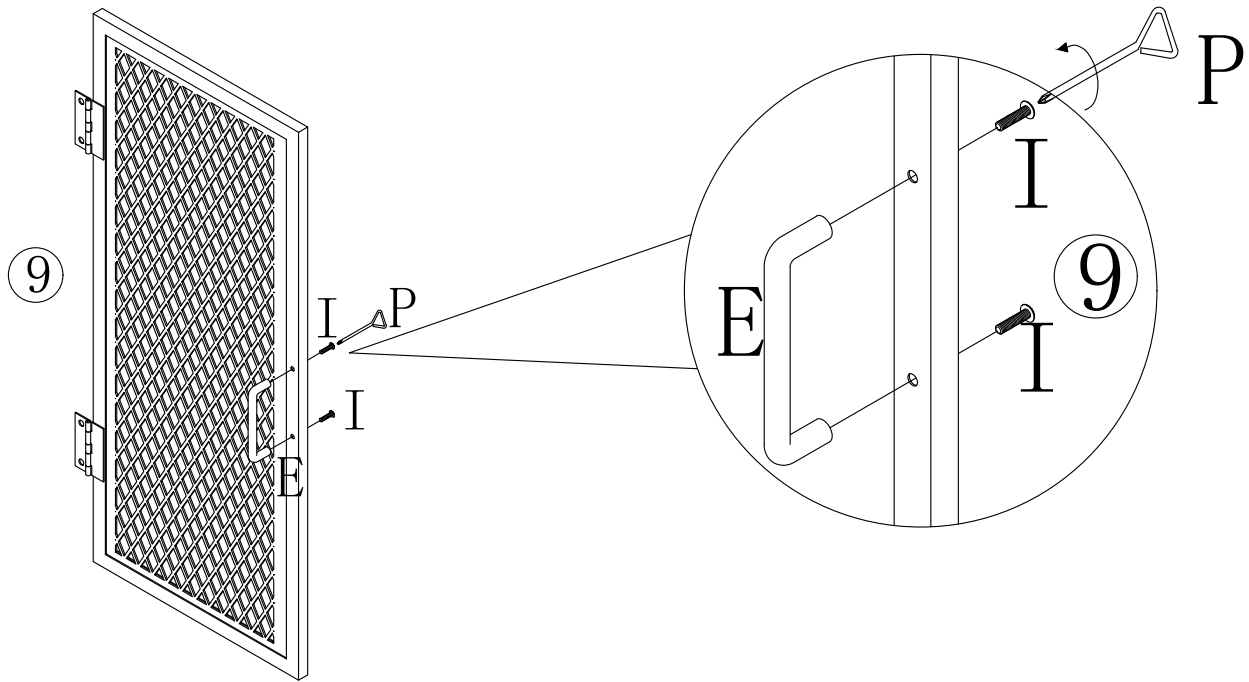

Step 23

Important Note: To avoid incorrect assembly, please follow our steps strictly.

🔌 Lay the cabinet on the carpet or cardboard. NOTE: Place back panel on the bottom side.

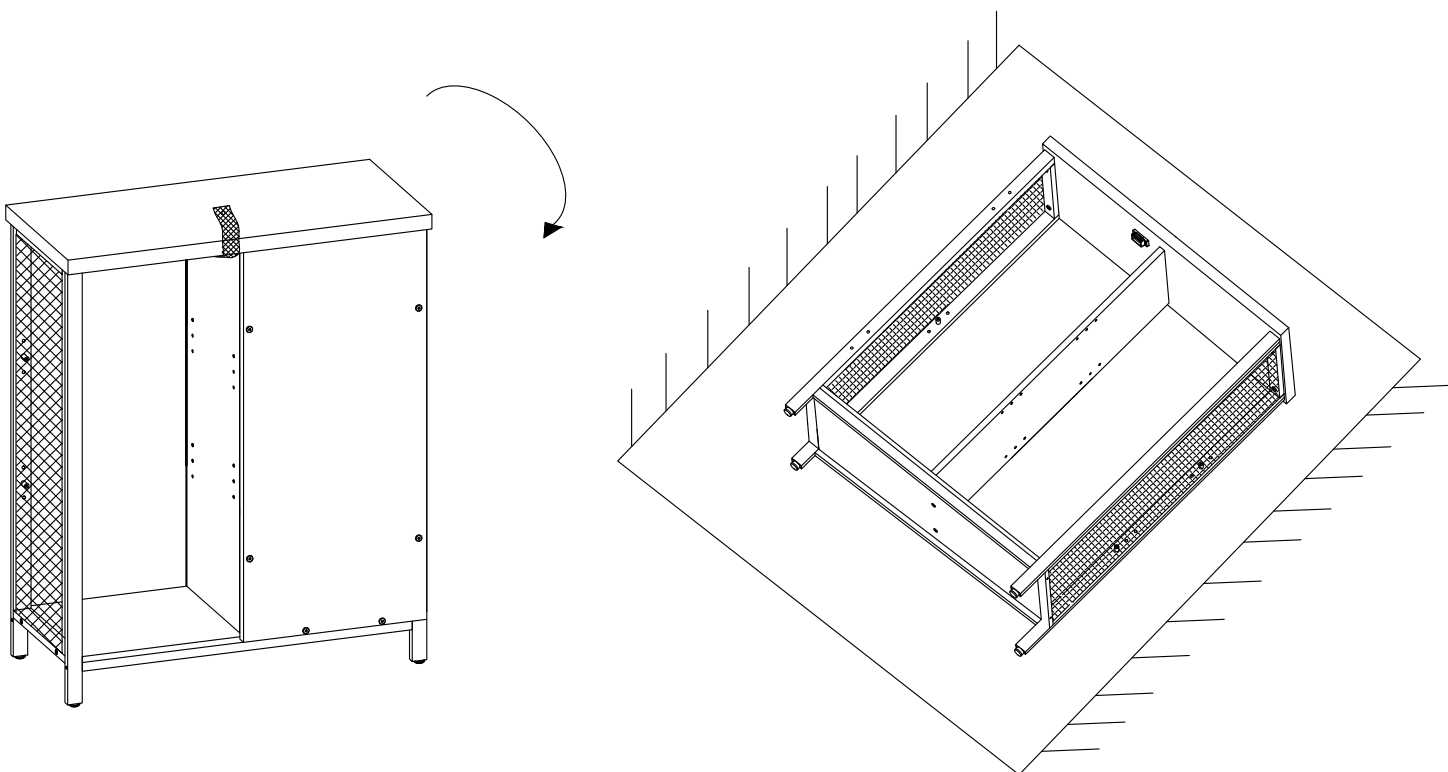

Step 24

Important Note: To avoid incorrect assembly, please follow our steps strictly.

🔧 Attached mesh door (⑨) to leg frame (①). Fully tighten by using 4 pcs short allen bolt (H) and allen key (O).

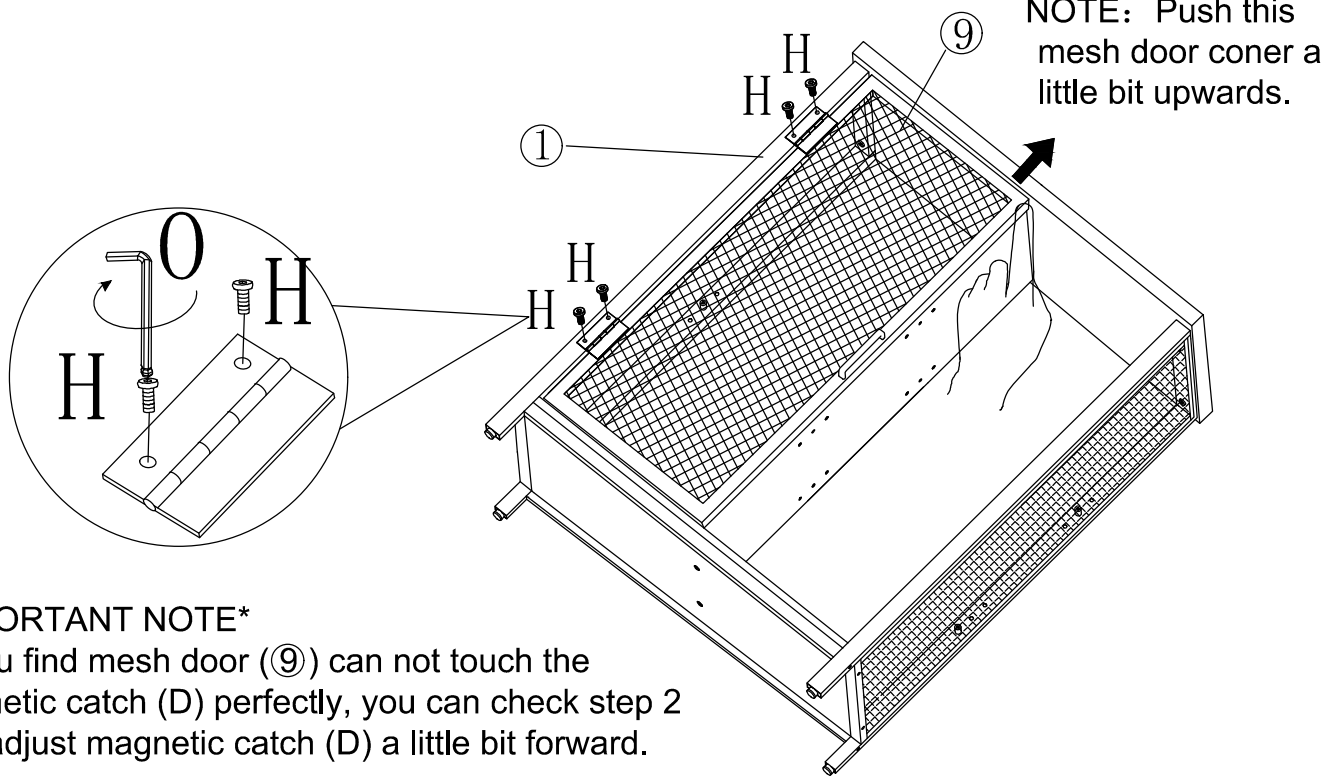

IMPORTANT NOTE

-If you find mesh door (⑨) can not touch the magnetic catch (D) perfectly, you can check step 2 and adjust magnetic catch (D) a little bit forward.

Step 25

Important Note: To avoid incorrect assembly, please follow our steps strictly.

🔧 Flip cabinet up and insert 2 pcs shelf (③) between right metal frame (②) and upright (⑥). then insert 1 pc shelf (③) between left metal frame (①) and upright (⑥). The shelves should slope downward, this is the easiest way to place shelf.

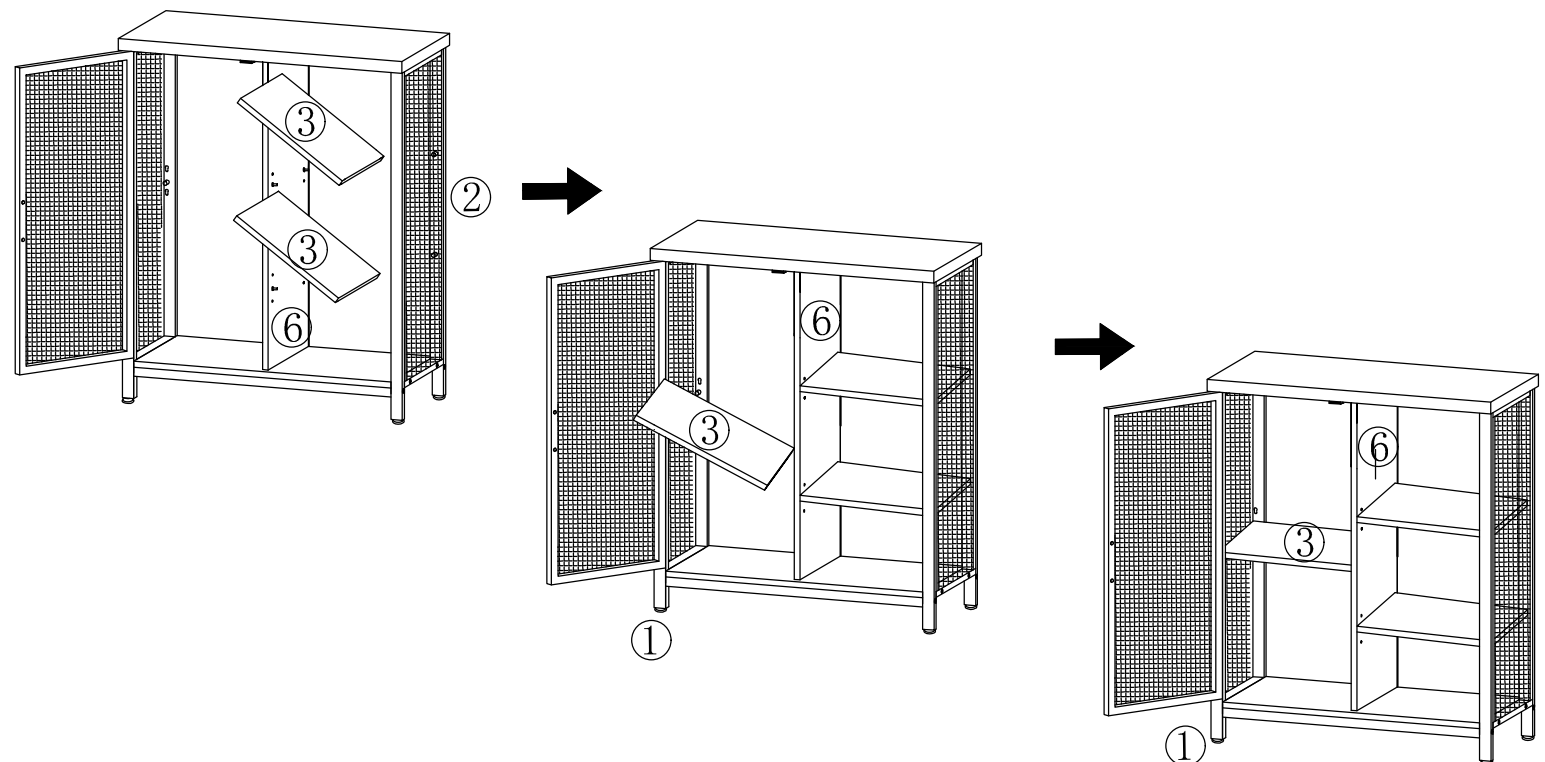

Step 26

Important Note: To avoid incorrect assembly, please follow our steps strictly.

🔌 If you find the mesh door tilt down a little bit, you can loosen the bolt (H) to adjust the gap.

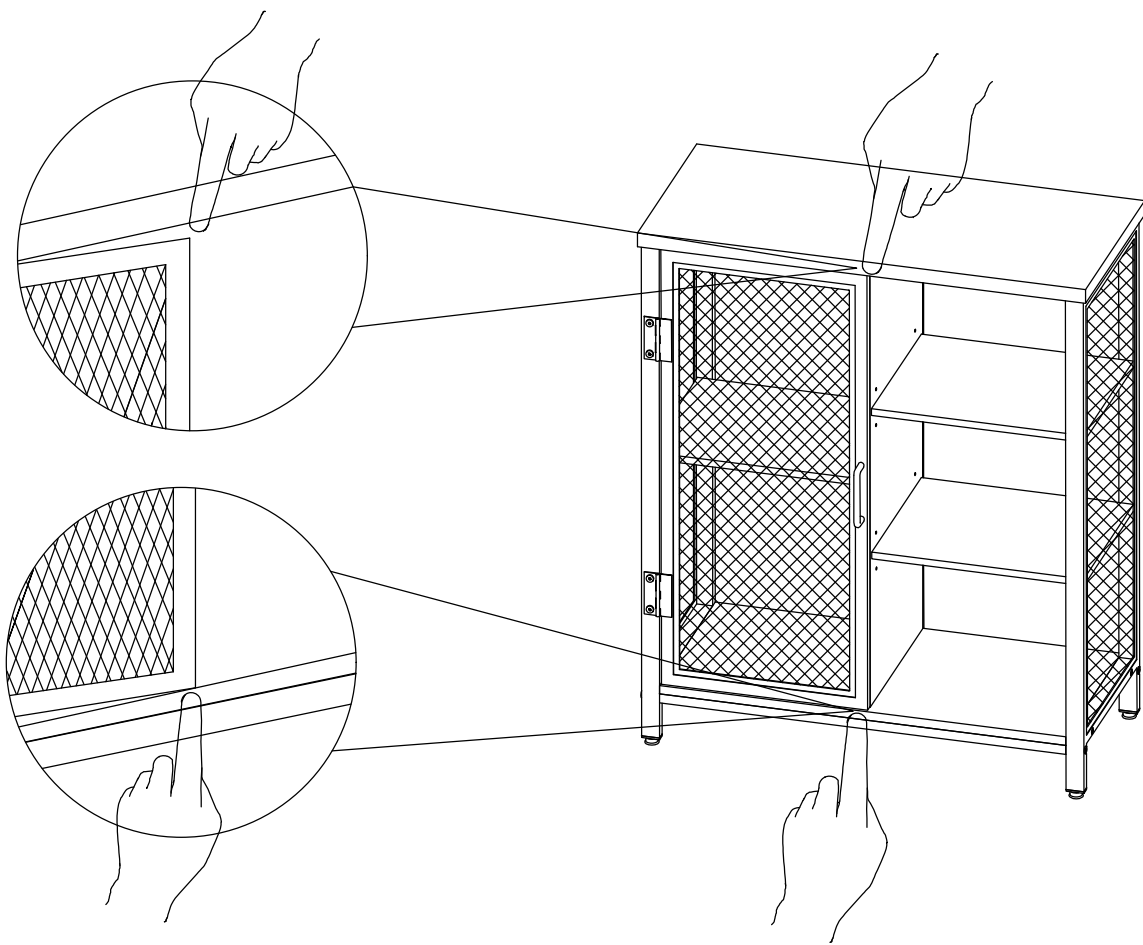

🔌 Contrarotate 4 pcs bolt (H) around 2 turns, just loosen the bolt (H) a little bit. Then lift mesh door up, and make sure the door edge parallel to bottom shelf. Then fully tighten 4 pcs bolt (H).

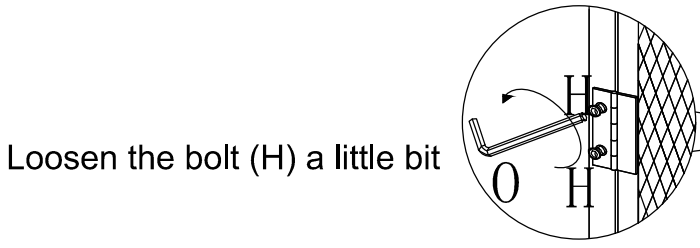
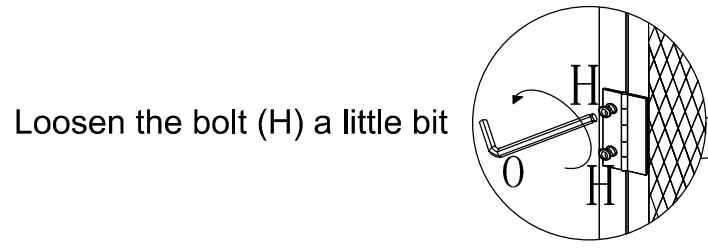

Lift mesh door up, the door edge should be parallel to bottom shelf. Then fully tighten allen bolts (H)

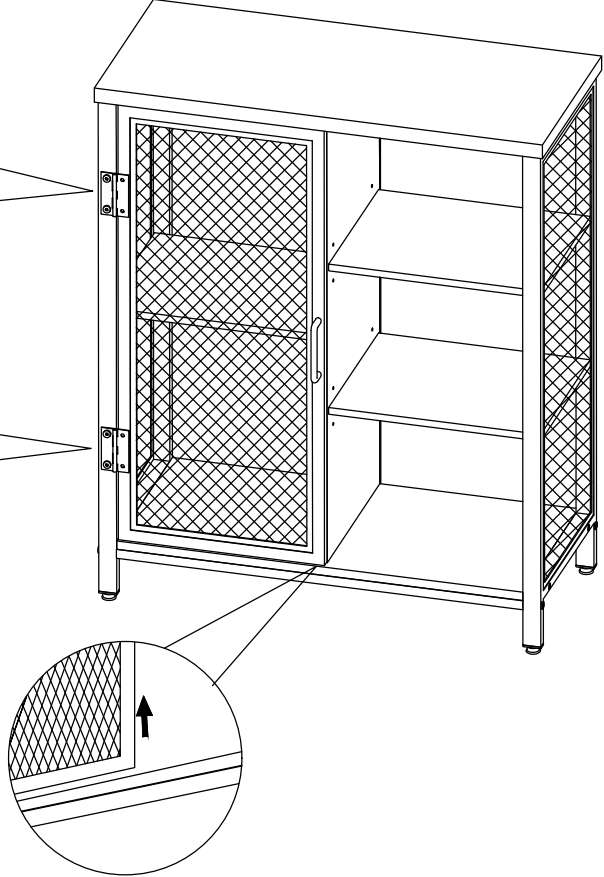

Step 27

Important Note: To avoid incorrect assembly, please follow our steps strictly.

📌 To prevent injury and property damage from unexpected tipping of furniture, we highly recommend installation of the anti-tip strap (N) included with this product. Drill holes at marked spot with a drill bit. Carefully hammer in the plastic anchors(M). Attach the anti-tip strap (N) to plastic anchors (M) by using long self-tapping screws(L), fix by using cross head screwdriver (P).

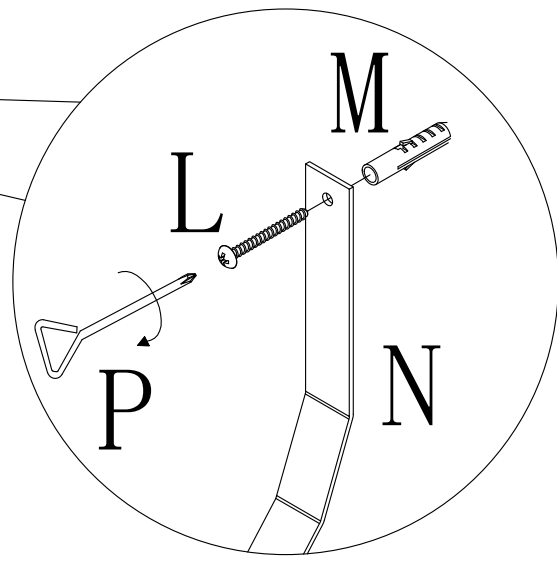
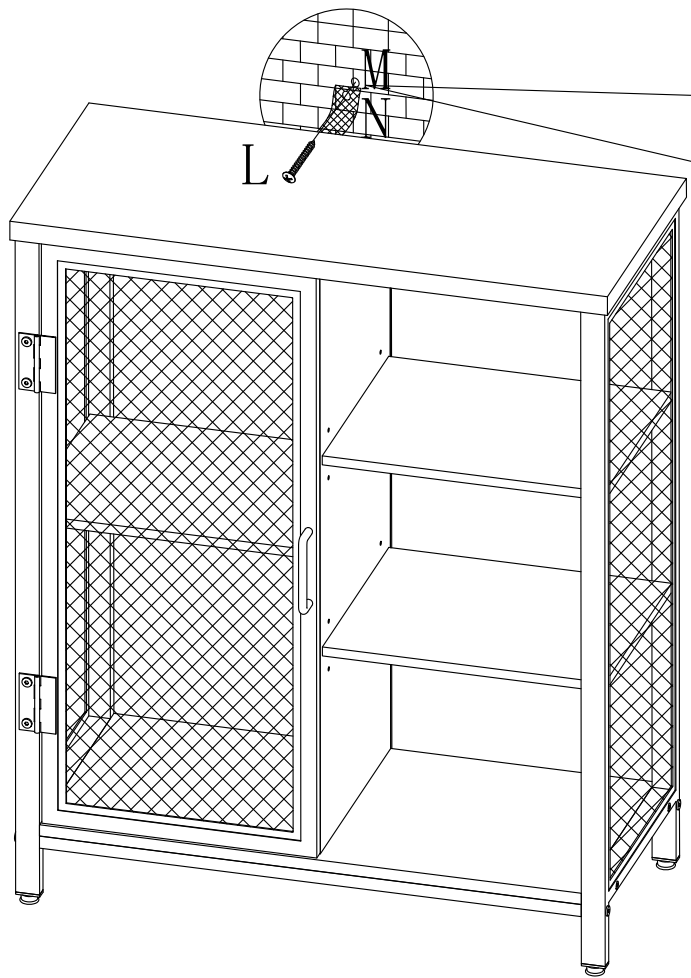
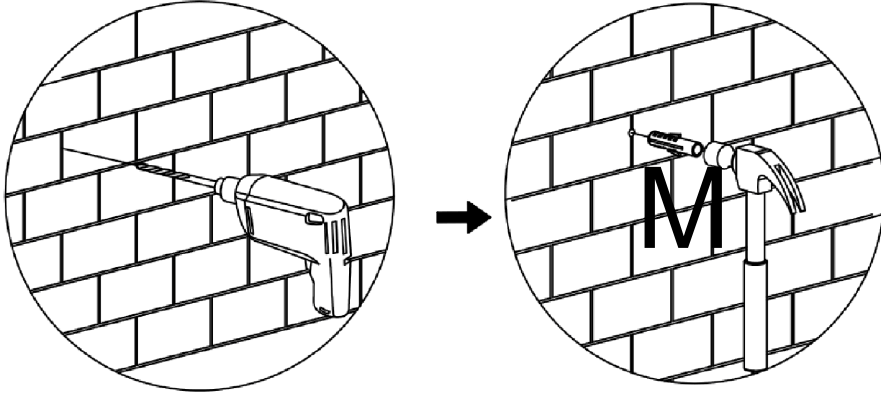

Important note: If you find the holes do not align together, you can loosen all the screws, and adjust the holes slightly. After all the holes were aligned together, you can fully tighten all the screws.

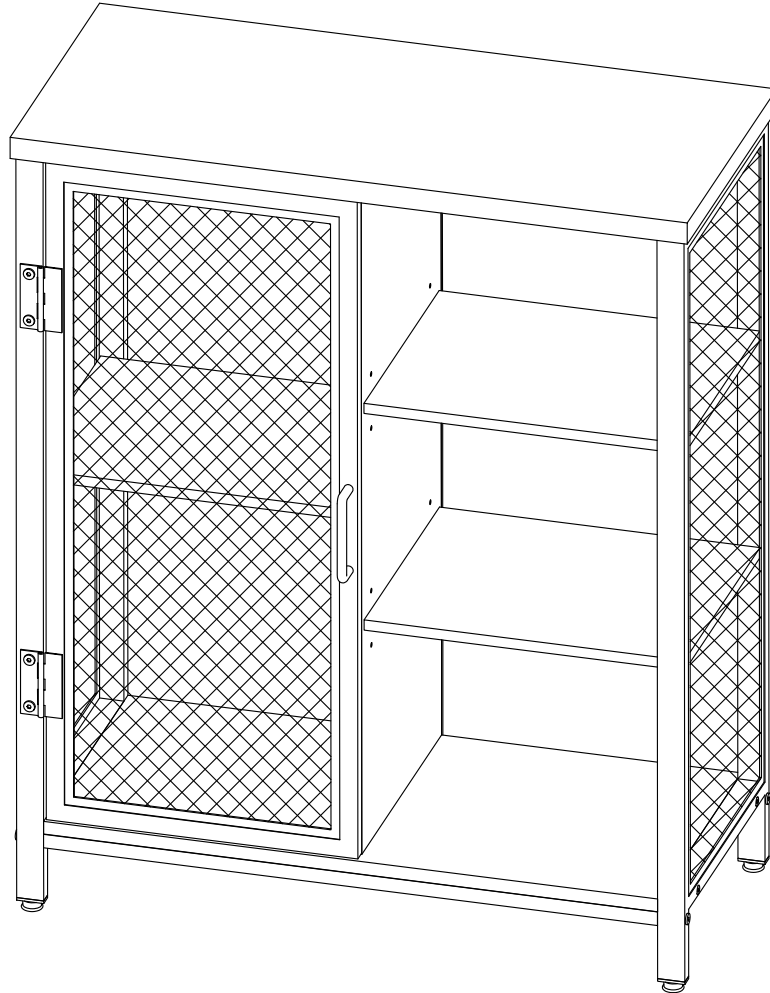

Finish Assembly

📌 If you have any questions with our products, please do not hesitate to contact with us at any time. Our email address is info@homedepot.com, we will reply your email within 24 hours.