

16558



Call Us First!
DO NOT RETURN TO STORE.

For questions on assembly or for general inquiries, you may contact us in the following ways:
Call customer service: **1-877-743-3400**

AVOID THE WAIT!

visit us online at
help.backyardproducts.com

- Submit a help request
- Answers to frequently asked questions
- Live chat with an agent



Did you enjoy building your shed?

JOIN OUR TEAM
AND MAKE UP TO \$1,500/WEEK*

Call a Recruiter Today! 734-365-7000



Flexible schedule



No selling,
just building



Bonus incentives
available

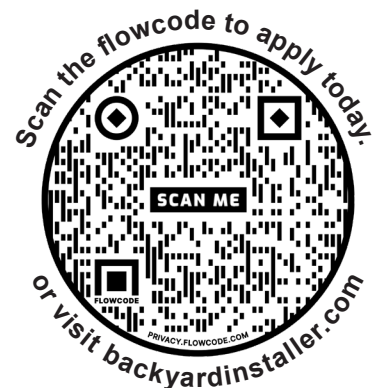

*based on number of completed installations

(This page intentionally left blank.)

ASSEMBLY MANUAL

GABLE 10' x 12' (304,8 x 365,8 cm)

	BUILDING SIZE	ACTUAL FLOOR SIZE
BASE MODEL	10' x 12' (304,8 x 365,8 cm)	10' x 12' (304,8 x 365,8 cm)
ADD 10' x 4'	10' x 16' (304,8 x 487,7 cm)	10' x 16' (304,8 x 487,7 cm)

KEEP THIS MANUAL FOR FUTURE REFERENCE

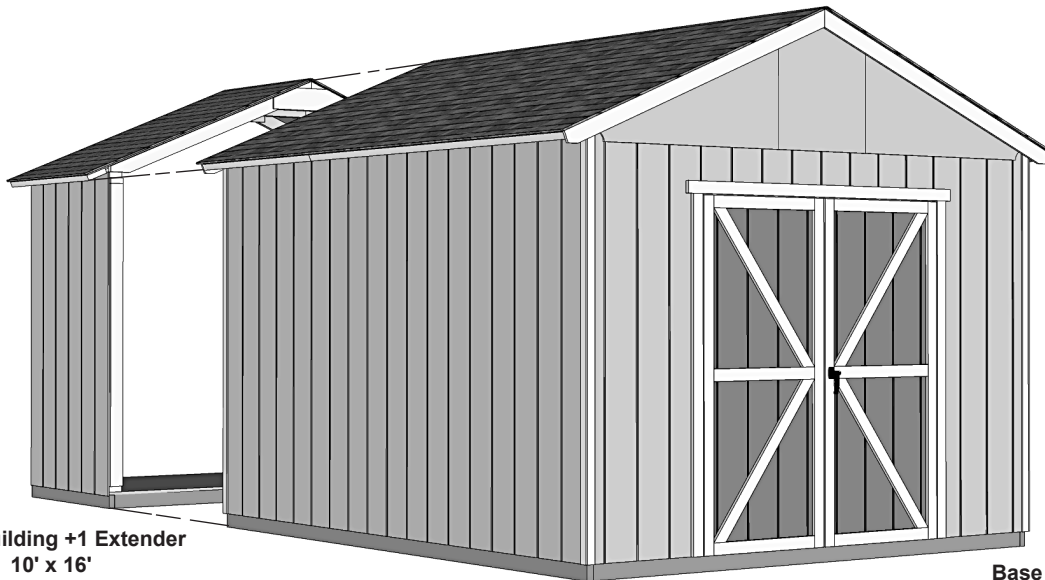

Base Building +1 Extender
10' x 16'

Base Building 10' x 12'

⚠ **IMPORTANT!** ⚠

READ INSTRUCTIONS THOROUGHLY PRIOR TO BEGINNING ASSEMBLY.

BEFORE YOU BEGIN

• BUILDING RESTRICTIONS AND APPROVALS

Be sure to check local building department and homeowners association for specific restrictions and/ or requirements before building.

• ENGINEERED DRAWINGS

Contact our Customer Service Team if engineered drawings are needed to pull local permits.

• SURFACE PREPARATION

To ensure proper assembly you must build your shed on a level surface.

Recommended methods and materials to level your shed are listed on page 10.

• CHECK ALL PARTS

Inventory all parts listed on pages 5-8.

• ADDITIONAL MATERIALS

You will need additional materials to complete your shed. See pages 3-4 for required and optional materials and quantities.



*****CONTACT OUR CUSTOMER SERVICE TEAM
IF ANY PARTS ARE MISSING OR DAMAGED*****











- Order form and warranty at back of manual -

Call: 1-877-743-3400 email: customerservice@backyardproductsllc.com







TOOLS

Required

- Phillips Screwdriver 
- Drill / Driver 
 - 3/8" Drill Bit
 - #2 Philips Drive Bit
- Hammer 
- Level 
- Pencil 
- Tape Measure 
- Square  or 

- Utility Knife 
 - Shingle Blades 
- Caulk Gun 
- Paint Tools 
- Safety Glasses 
- Ladder 

Optional

- Tool Belt/ Nail Pouch 
- Tin Snips (for drip edge) 
- Chalk Line 
- Nail Gun 
 - gun nails
- Gloves 
- Sawsall 

Safety! Always use approved safety glasses during assembly.

HELPFUL REMINDER SYMBOLS

Look for these symbols for helpful reminders throughout this manual.



= Assistance Required; two or more people.



= Ensure squareness.



= Important required step or operation.



= Helpful assembly hint.



= Mark part with pencil.



BEGIN = Beginning of steps for assembly or installation.



FINISH = You have finished the assembly or installation.



= Level

ORIENT LUMBER AND TRIM FOR BEST APPEARANCE

Framing lumber is graded for structural strength and not appearance. Exterior trim is graded for one good side.

Always install the material leaving the best edge and best surface visible. Please remember that these blemishes in no way negatively affect the strength or integrity of our product. (See Fig. A, B, C.)

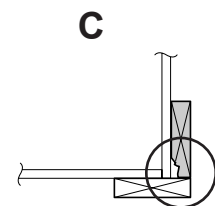
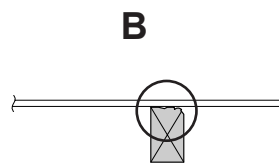
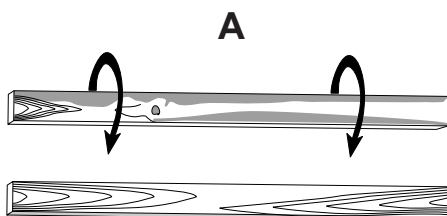

ADDITIONAL MATERIALS

FOUNDATION OR FLOOR MATERIALS

- This shed does not include any floor or leveling materials.
- See the FLOOR LEVELING section on page 10 for recommended methods and suggested materials to properly level your floor, as this will vary depending on your specific site.

REINFORCED WOOD FLOOR FRAME (OPTIONAL)

IMPORTANT! Depending on your specific use you may want to construct a heavy duty floor frame by adding additional floor joists (shown below as shaded). Below is a list of additional materials (not included):

10x12'

- x3** 2 x 4 x 10' (5,1 x 10,2 x 304,8 cm) Treated Lumber cut to 2 x 4 x 117" (5,1 x 10,2 x 297,2 cm)
- x12** 3" (7,6 cm) hot-dipped galvanized nails

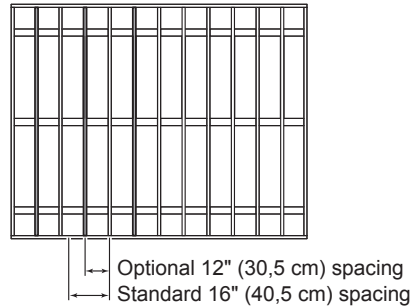

10x16'

- x4** 2 x 4 x 10' (5,1 x 10,2 x 304,8 cm) Treated Lumber cut to 2 x 4 x 117" (5,1 x 10,2 x 297,2 cm)
- x16** 3" (7,6 cm) hot-dipped galvanized nails

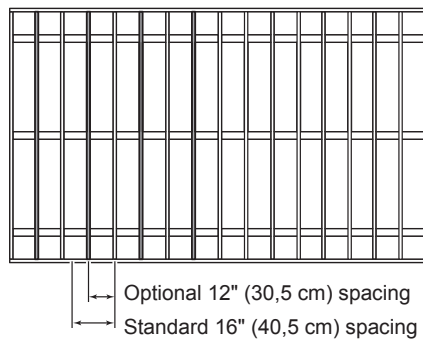

ADDITIONAL MATERIALS

COMPLETING YOUR SHED

You will need these additional materials:

	10x12'	10x16'	ALL SIZES
<input type="checkbox"/> 3-TAB SHINGLES (Bundles).....	6	8	
<input type="checkbox"/> PAINT FOR SIDING (Gallons)..... Use 100% acrylic latex exterior paint. (2) coats recommended.	3	3	<input type="checkbox"/> PAINT FOR TRIM1 Quart Use 100% acrylic latex exterior paint.
<input type="checkbox"/> 1" GALVANIZED ROOFING NAILS(lbs). For shingles.	3	4	<input type="checkbox"/> CAULK ...10x12 - 3 Tubes ...10x16 - 4 Tubes Use acrylic latex exterior caulk that is paintable. 

OPTIONAL MATERIALS



	10x12'	10x16'
<input type="checkbox"/> DRIP EDGE (Feet).....	60	60
<input type="checkbox"/> #15 ROOFING FELT (Sq ft. to cover).....	168	224
<input type="checkbox"/> 1" GALVANIZED ROOFING NAILS(lbs).... For roofing felt.	1/4	1/4

REFER TO THE BACK OF THIS MANUAL AND THE MANUFACTURER'S INSTRUCTIONS FOR INSTALLATION OF SHINGLES, DRIP EDGE AND FELT.

FLOOR PANELS (Not Included)

You will need floor panels and nails to complete your floor.
Floor panel sizes and quantities are shown below.

NOTE: Use a minimum of 5/8" (1,6 cm) Oriented Strand Board (OSB)

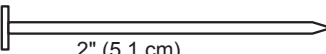
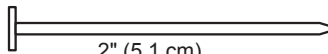
10x12'	10x16'
<input type="checkbox"/> x4  5/8" x 48" x96" (1,6 x 121,9 x 243,8 cm)	<input type="checkbox"/> x5  5/8" x 48" x96" (1,6 x 121,9 x 243,8 cm)
<input type="checkbox"/> x1  2" (5,1 cm) 1 lb. of 2" (5,1 cm) Hot Dipped Galvanized Box-Type Nails.	<input type="checkbox"/> x2  2" (5,1 cm) 1 lb. of 2" (5,1 cm) Hot Dipped Galvanized Box-Type Nails.

NAIL BOXES (Shown Actual Size)

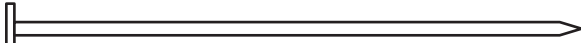
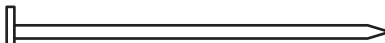
<input type="checkbox"/> x5 BOXES		3" (7,6 cm)
<input type="checkbox"/> x6 BOXES		2" (5,1 cm)

PARTS IDENTIFICATION AND SIZES

Double letter part identification is stamped on some parts.

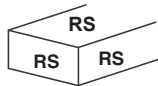

• Check these locations for part stamp.

WOOD SIZE CONVERSION CHART

Nominal Board Size	Actual Size
2 x 4	1-1/2" x 3-1/2" (3,8 x 8,9 cm)
1 x 4	3/4" x 3-1/2" (1,9 x 8,9 cm)
2 x 3	1-1/2" x 2-1/2" (3,8 x 6,3 cm)
1 x 3	3/4" x 2-1/2" (3,8 x 6,3 cm)

10x12'



GABLE 10' x 12' PARTS LIST

INVENTORY YOUR PARTS before you begin.

We suggest sorting parts by the category they are listed in.

WALL

- x5 **AL** 2 x 4 x 7" (5,1 x 10,2 x 17,8 cm)
- x4 **AF** 2 x 4 x 18-1/8" (5,1 x 10,2 x 46 cm)
- x2 **JBD** 2 x 4 x 20-3/8" (5,1 x 10,2 x 51,8 cm)
- x2 **RL** 2 x 4 x 24" (5,1 x 10,2 x 61 cm)
- x2 **SL** 2 x 4 x 36" (5,1 x 10,2 x 91,4 cm)
- x2 **HVC** 2 x 4 x 44-3/8" (5,1 x 10,2 x 112,7 cm)
- x2 **SP** 2 x 4 x 48" (5,1 x 10,2 x 121,9 cm)
- x1 7/16" x 3-1/4" x 66-3/4" (1,1 x 8,3 x 170,2 cm) OSB
- x2 **AM** 2 x 4 x 67" (5,1 x 10,2 x 170,2 cm)
- x2 **UM** 2 x 4 x 68" (5,1 x 10,2 x 172,7 cm)
- x4 **YFA** 2 x 4 x 68-1/2" (5,1 x 10,2 x 174 cm)
- x22 **AI** 2 x 4 x 78-1/2" (5,1 x 10,2 x 199,4 cm)
- x2 **TO** 2 x 4 x 84" (5,1 x 10,2 x 213,4 cm)
- x4 **TJ** 2 x 4 x 92-5/8" (5,1 x 10,2 x 235,3 cm)
- x4 **TP** 2 x 4 x 96" (5,1 x 10,2 x 243,9 cm)

x1 **GAA** 1 x 3 x 5" (2,5 x 7,6 x 12,7 cm)
Used as a gauge block for 3/4" (1,9 cm) measurement.

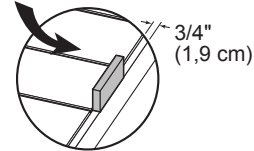

RAFTERS

- x12 6 x 24" (15,2 x 61 cm)
- x1 **TM** 2 x 4 x 72" (5,1 x 10,2 x 182,9 cm)
- x14 **AD** 2 x 4 x 65" (5,1 x 10,2 x 165,1 cm)

TRIM

- x2 **WTC** 2 x 6 x 49-3/4" (5,1 x 15,2 x 126,4 cm)
- x2 **AUR** 19/32" x 3-1/2" x 71-15/16" (1,5 x 8,9 x 182,7 cm)
- x2 **AUL** 19/32" x 3-1/2" x 71-15/16" (1,5 x 8,9 x 182,7 cm)
- x8 3/8" x 1-3/4" x 83-1/2" (1 x 4,5 x 212,1 cm)
- x2 **VX** 2 x 6 x 96" (5,1 x 15,3 x 243,9 cm)

PANEL & DOORS PARTS LIST

NOTE: Panel parts are not stamped with part identification.

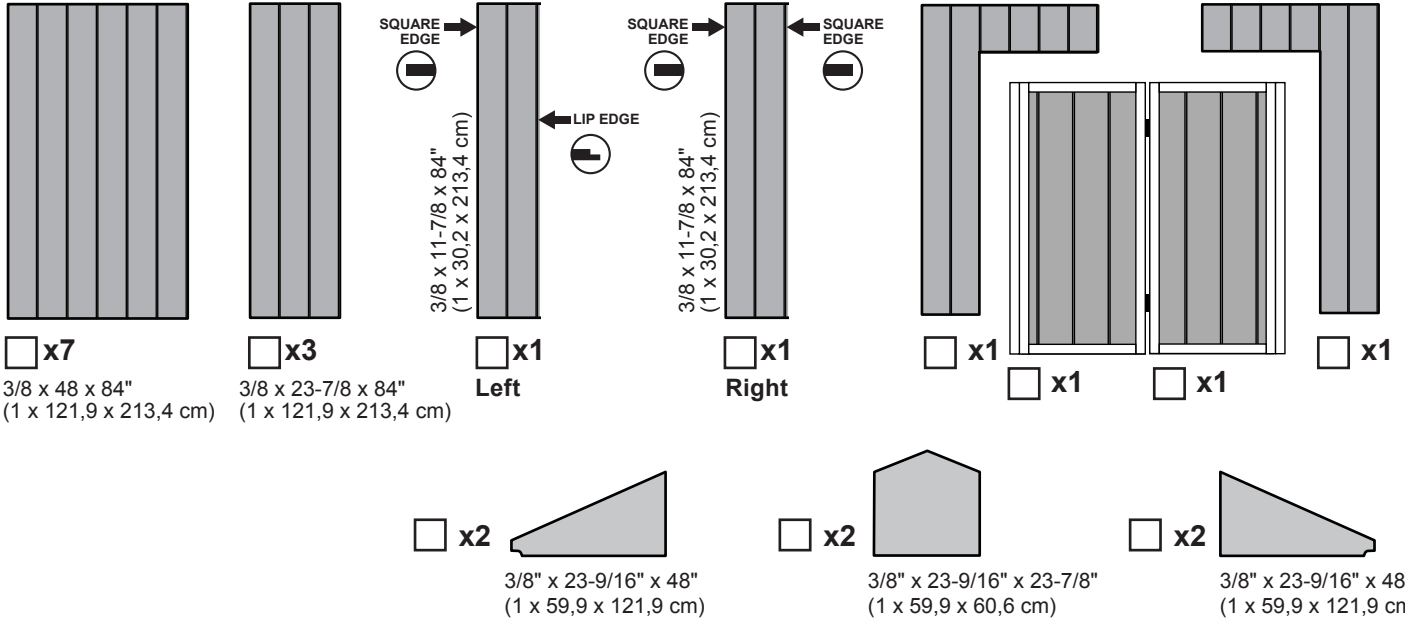

ROOF PANELS

Roof panels are 7/16" (1,1 cm) thick.

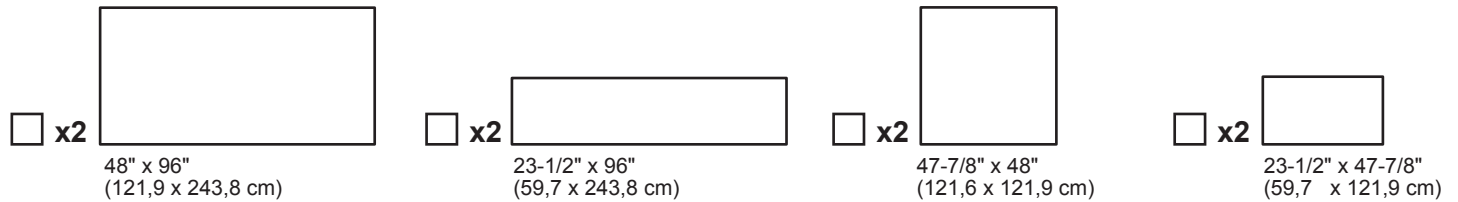

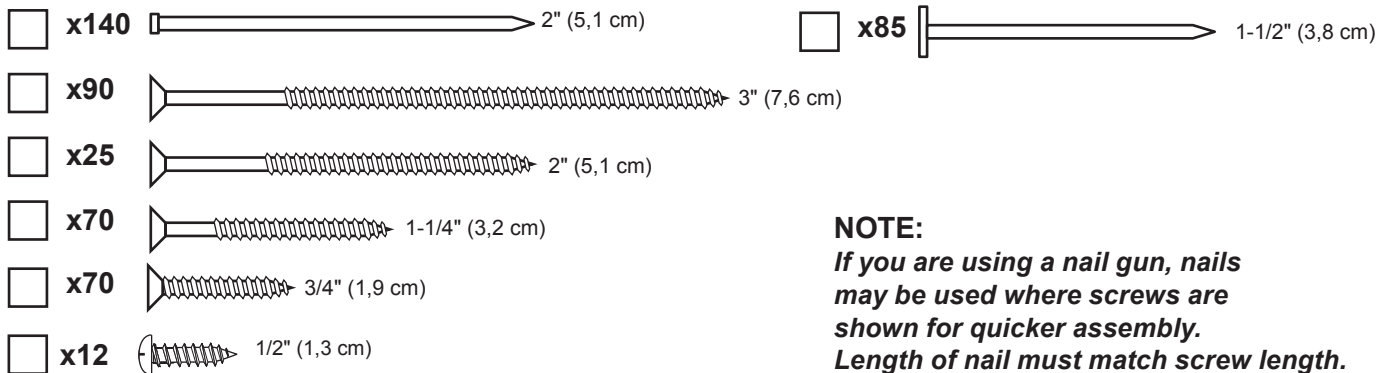

FASTENER/HARDWARE BAG (Shown Actual Size)



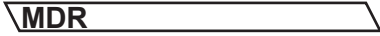
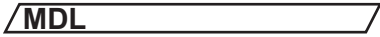
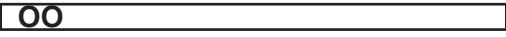
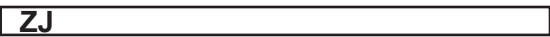

DOOR TRIM

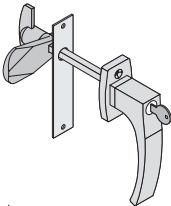
- x2 **AH**  19/32" x 2-1/2" x 26-5/8" (1,5 x 6,3 x 67,7 cm)
- x2 **MDR**  19/32" x 2-1/2" x 39-7/8" (1,5 x 6,3 x 101,3 cm)
- x2 **MDL**  19/32" x 2-1/2" x 39-7/8" (1,5 x 6,3 x 101,3 cm)
- x2 **OO**  69" (175,3 cm) Door Stiffener
- x1 **ZJ**  19/32" x 2-1/2" x 72" (1,5 x 6,3 x 182,9 cm)

Other HARDWARE (Not Actual Size)

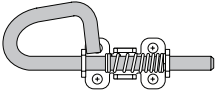
- x1 
- x2  1" (2,5 cm)
- x2  1-1/4" (3,2 cm)

- x2 
- x8  3/4" (1,9 cm)

- x2 

PARTS IDENTIFICATION AND SIZES

Part identification is stamped on some parts.

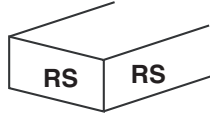

• Check these locations for part stamp.

WOOD SIZE CONVERSION CHART	
Nominal Board Size	Actual Size
2 x 4	1-1/2" x 3-1/2" (3,8 x 8,9 cm)
1 x 4	3/4" x 3-1/2" (1,9 x 8,9 cm)
2 x 3	1-1/2" x 2-1/2" (3,8 x 6,3 cm)
1 x 3	3/4" x 2-1/2" (3,8 x 6,3 cm)

10x4'





GABLE 10' x 4' EXTENDER KIT PARTS LIST

INVENTORY YOUR PARTS before you begin.

We suggest sorting parts by the category they are listed in.

WALL

x6 **SP**  2 x 4 x 48" (5,1 x 10,2 x 121,9 cm)

x4 **AI**  2 x 4 x 78-1/2" (5,1 x 10,2 x 199,4 cm)

x2  3/8 x 48 x 84"
(1 x 121,9 x 213,4 cm)

RAFTERS

x4  6 x 24" (15 x 60,1 cm)

x4 **AD**  2 x 4 x 65" (5,1 x 10,2 x 165,1 cm)

x1 **TM**  2 x 4 x 72" (5,1 x 10,2 x 182,9 cm)

TRIM

x2 **VF**  2 x 6 x 48" (5,2 x 15,2 x 121,9 cm)

HARDWARE

x12  3" (7,6 cm)

x12  1-1/4" (3,2 cm)

ROOF PANELS

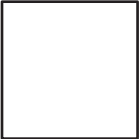
x2  47-7/8" x 48"
(121,6 x 121,9 cm)

x2  23-1/2" x 47-7/8"
(59,7 x 121,9 cm)

Roof panels are 7/16" (1,1 cm) thick.

OPTIONAL WOOD FRAME FLOOR LEVELING OPTIONS

There are multiple ways to level your floor frame. Our recommended leveling method is shown below.

Leveling materials are not included in this kit.

PREFERRED METHOD - 4x4 TREATED RUNNERS (Typical for 10' x 12' Kit)

Runners are generally 12" (30,5 cm) from ends of floor frame and under seams.

Measurements to centers of 4x4's.

- 3" Screws angled into 4x4.
- (2) at each point frame and 4x4 touch.

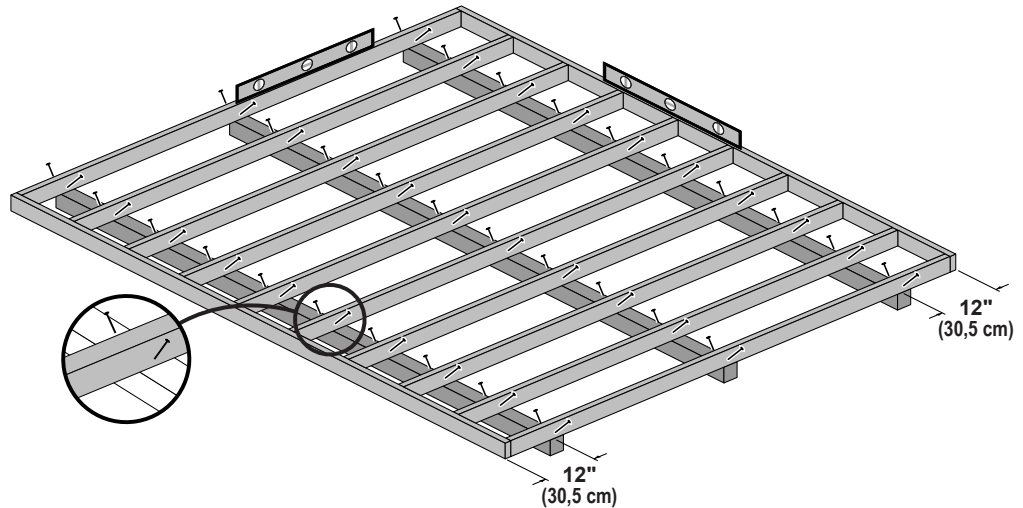

! FLOOR FRAME NOT INCLUDED

Fasteners for Frame to 4x4:
(3" Screws shown as one option.)
Minimum 3" screws / exterior grade.

MATERIAL REQUIRED:

10' x 12' x3 4 x 4 x 12' (10,2 x 10,2 x 305 cm) Treated Lumber

10' x 16' x3 4 x 4 x 16' (10,2 x 10,2 x 487,7 cm) Treated Lumber

x60  3" (7,6 cm)

x78  3" (7,6 cm)

! Use only wood treated for ground contact and fasteners approved for use with treated wood.

! Always support frame seams.

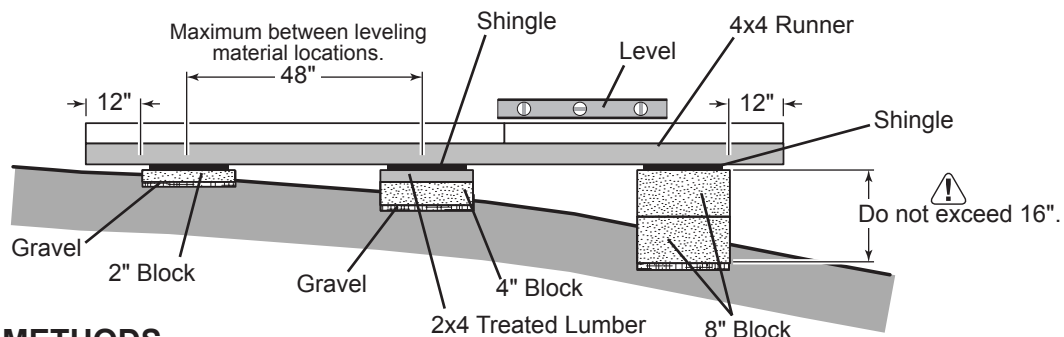

LEVELING METHODS

- Level under 4x4 runners only.
- Locate leveling material 12" from ends of runners and no more than 48" apart.
- Asphalt shingles should be used between 4x4 runners and blocks or treated lumber. Never use shingles in direct contact with ground.
- For best results and aiding in water drainage use gravel under each concrete block.

LEVELING MATERIALS

- Gravel
- Solid Masonry Blocks in 1", 2", 4" or 8" thickness
- 2x4 Treated Lumber
- Asphalt Shingles

! Leveling higher than 16" not recommended.

LEVELING & SQUARING THE FLOOR FRAME (Not Included)

STOP!



LEVEL AND SQUARE FLOOR FRAME



STOP!

Before attaching floor decking, it is important to level and square the floor frame. A level and square floor frame is required to correctly construct your shed.

See page 10 for the preferred floor leveling method.

BEGIN Use a level and ensure the frame is level before applying floor panels.

- 1 Check for frame squareness by measuring diagonally across the corners. If the measurements are the same, the frame is square.
 - The diagonal measurement for 10' x 12' will be approximately **187-7/16"** (476,1 cm) (Fig. A).
 - The diagonal measurement for 10' x 16' will be approximately **226-7/16"** (575,2 cm) (Fig. C).
- 2 After the frame is level and square, secure one side of frame to 4x4 runners using one fastener at ends of each runner. At the opposite end of the frame, secure the frame to 4x4 runners with one fastener at the ends of each runner, ensuring that the frame remains square. Fasten the frame to the 4x4 runners with (2) 3" screws at each connection (Fig. B).

4x4 runners are generally installed 12" (30,5 cm) from ends of floor frame and under any seams.

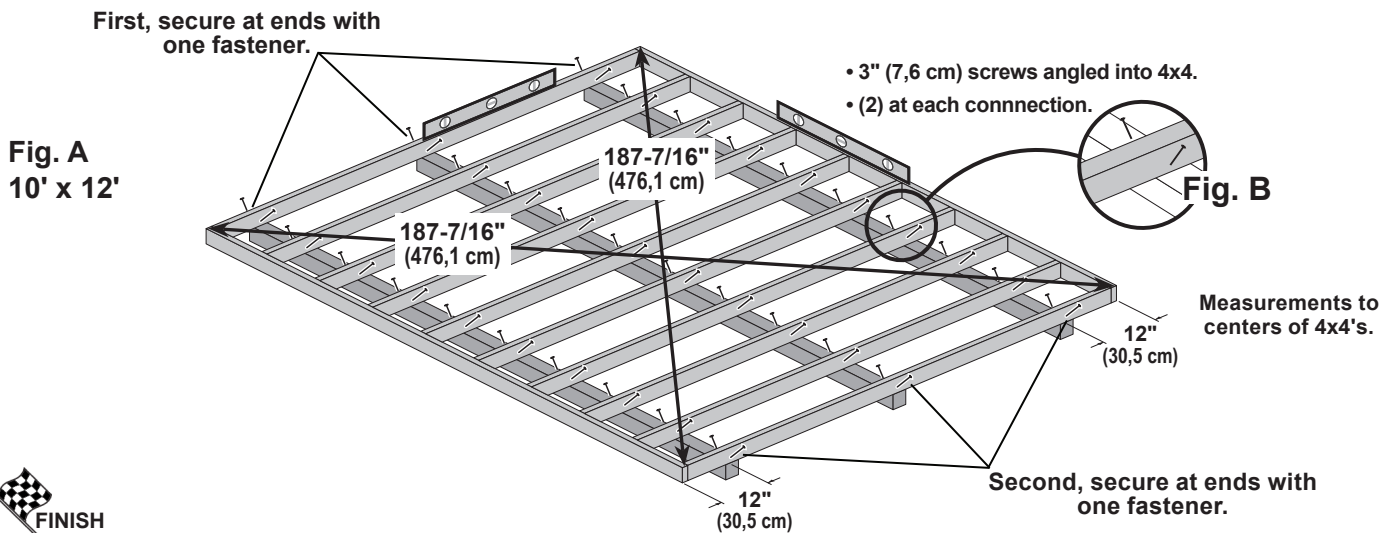

Your floor frame is now level.

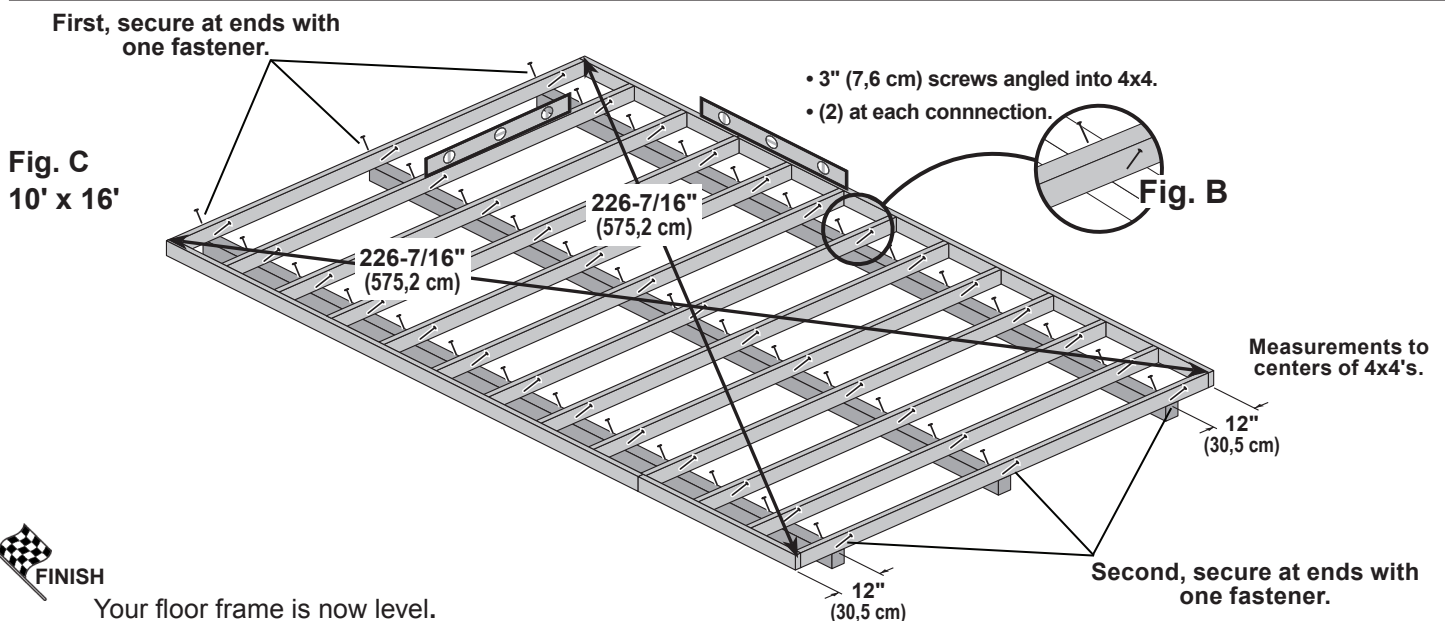

Your floor frame is now level.

! IMPORTANT!

NOTE: 10' x 12' Gable shown standard throughout manual



Ensure the floor frame is level after installing floor panels. Re-level if needed.

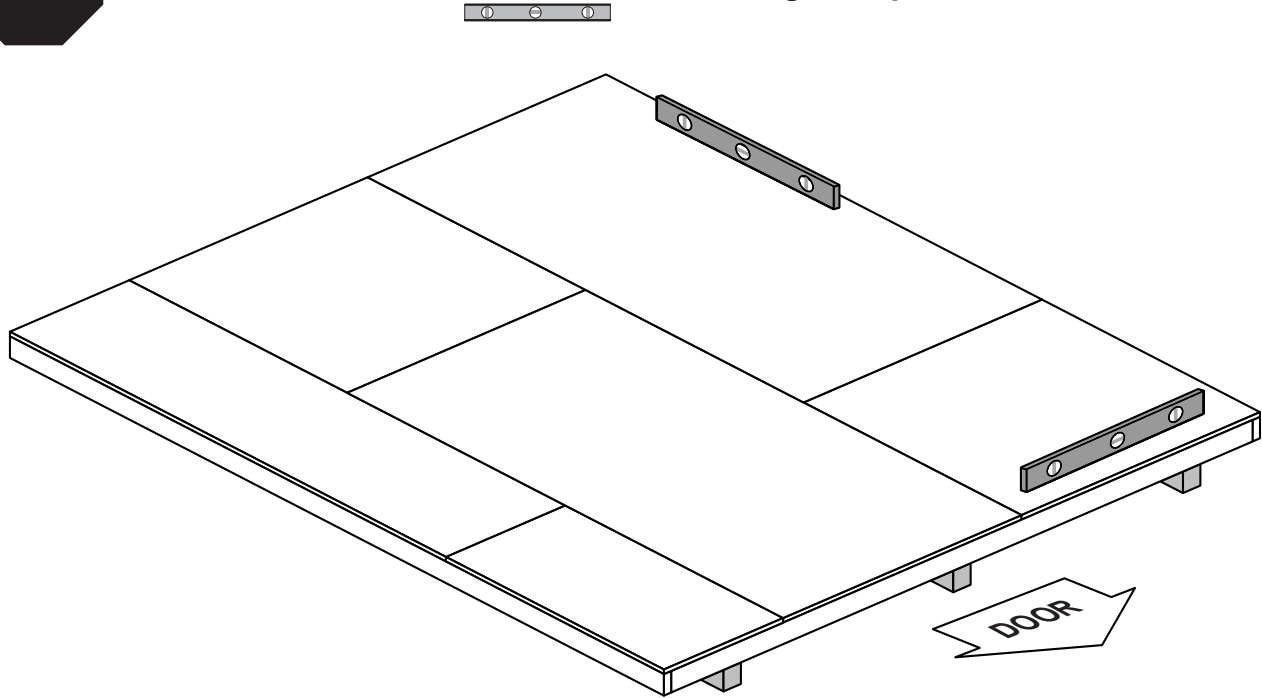

HINT:

- The floor should be used as a stable work surface for wall construction.
- Organize your assembly procedure during the build process to avoid over-handling of the walls.

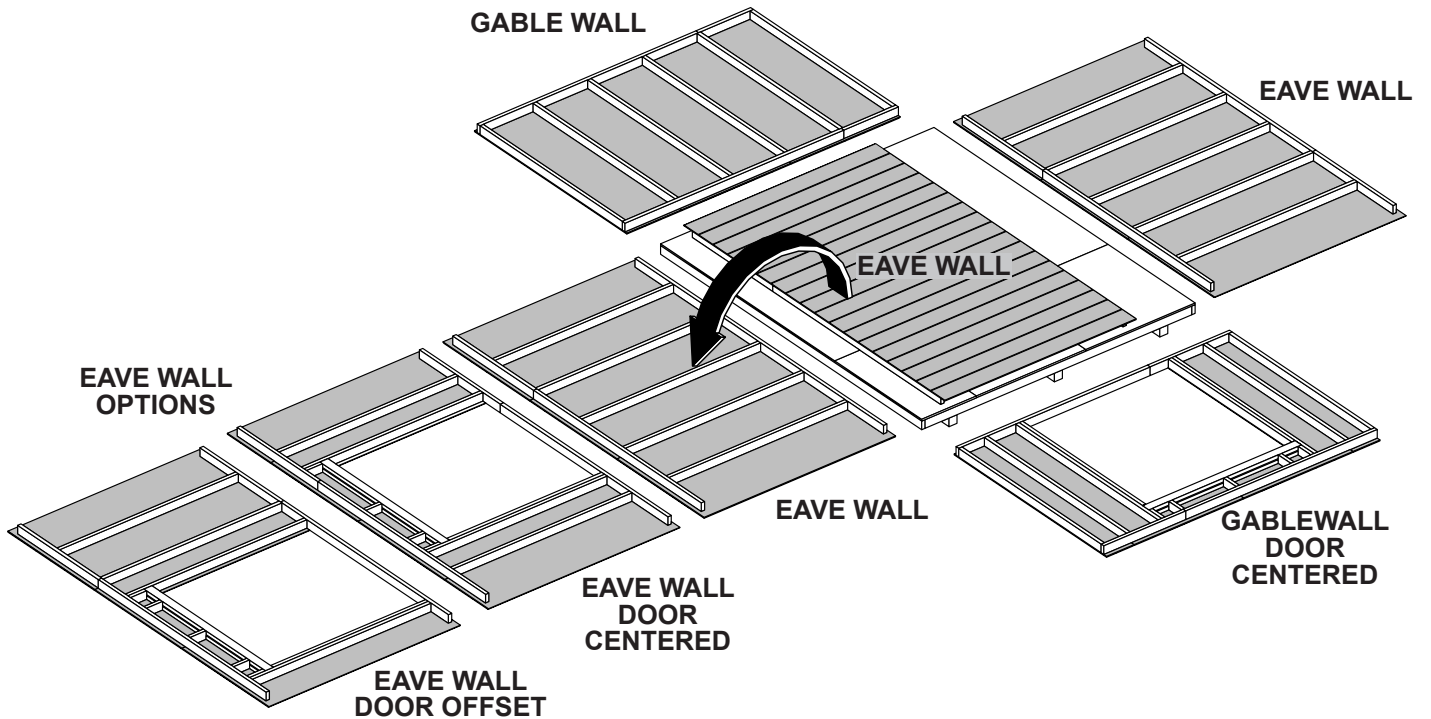

(This page intentionally left blank.)

WALL CONFIGURATION GUIDE

Create your own style of shed. Choose your door location.
Compare this guide with the wall index to find the corresponding pages.

10' x 12'

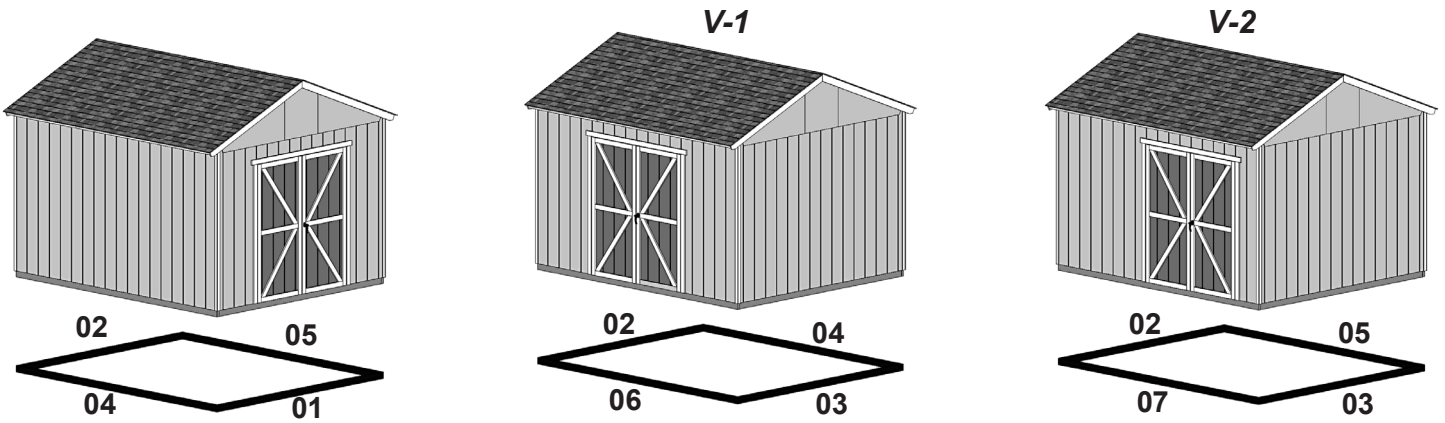

10' x 16'

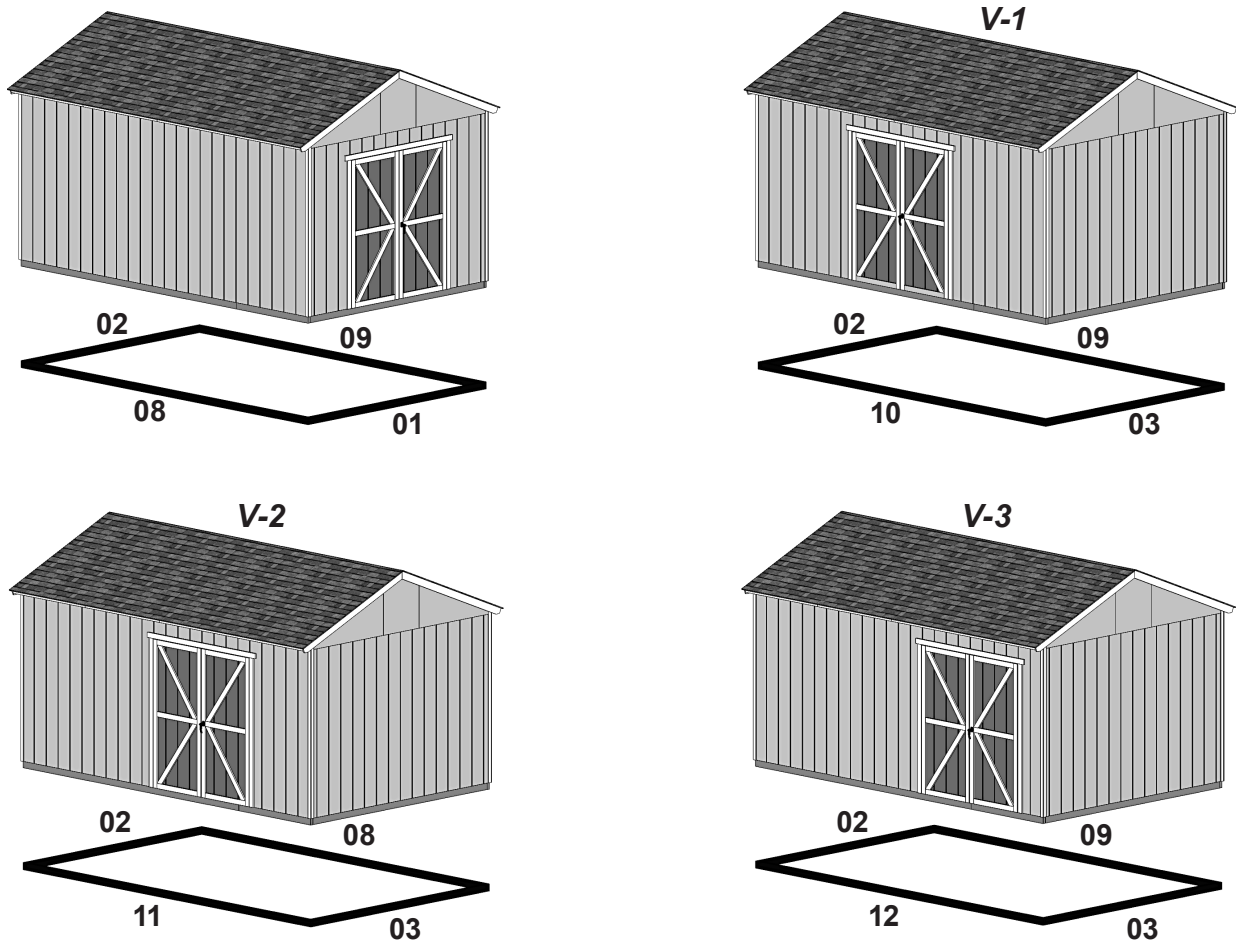

HINT:

Streamline your wall assembly process by cutting out the pages for the wall configuration guide and the wall index.



CUT HERE

WALL INDEX

As another option, eave walls with doors can be reversed during assembly.

10' x 12' After assembling the walls for your 10' x 12' shed, go to page 42 for wall installation.

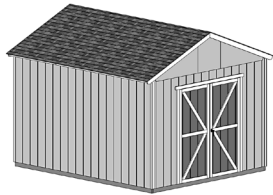

10' x 12'

Door is on the 10' wall.

Wall 01: Page 18

Wall 02: Page 20

Wall 04: Page 24

Wall 05: Page 26

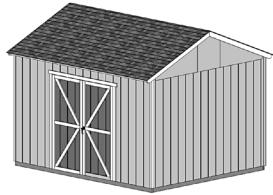

10' x 12' V-1

Door is on the 12' wall, centered.

Wall 02: Page 20

Wall 03: Page 22

Wall 04: Page 24

Wall 06: Page 28

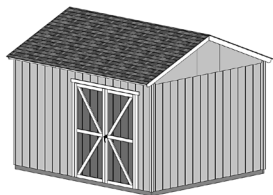

10' x 12' V-2

Door is on the 12' wall, offset.

Wall 02: Page 20

Wall 03: Page 22

Wall 05: Page 26

Wall 07: Page 30

10' x 16' After assembling the walls for your 10' x 16' shed, go to page 48 for wall installation.

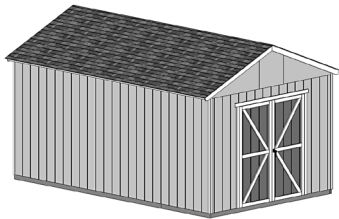

10' x 16'

Door is on the 10' wall.

Wall 01: Page 18

Wall 02: Page 20

Wall 08: Page 32

Wall 09: Page 34

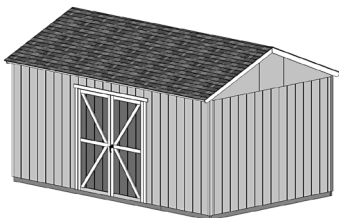

10' x 16' V-1

Door is on the 16' wall, centered.

Wall 02: Page 20

Wall 03: Page 22

Wall 09: Page 34

Wall 10: Page 36

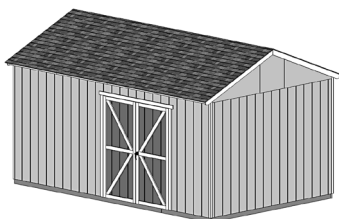

10' x 16' V-2

Door is on the 16' wall, offset.

Wall 02: Page 20

Wall 03: Page 22

Wall 08: Page 32

Wall 11: Page 38

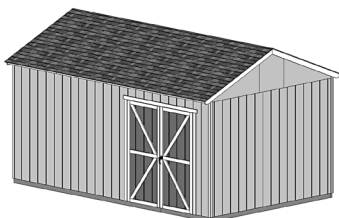

10' x 16' V-3

Door is on the 16' wall, extra-offset.

Wall 02: Page 20

Wall 03: Page 22

Wall 09: Page 34

Wall 12: Page 40

DOOR HEADER

STOP!

Assemble this door header before building any walls!

Any wall with a door will require this assembly.

STOP!

PARTS REQUIRED:

x2 **AM**
2 x 4 x 67" (5,1 x 10,2 x 170,2 cm)

x1
7/16 x 3-1/4 x 66-3/4" (1,1 x 8,3 x 170,2 cm) **OSB**

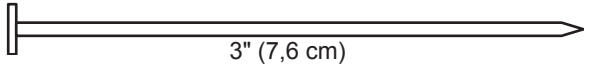
x18  3" (7,6 cm)

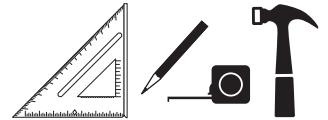

✓ **BEGIN**

- 1 Place (1) **AM** and **OSB** end-to-end on flat surface, flush in middle.
Center **OSB** on top of **AM**.

Fasten together with 3" nails in the pattern shown.

- 2 Flip header assembly over and nail as shown on the other side.

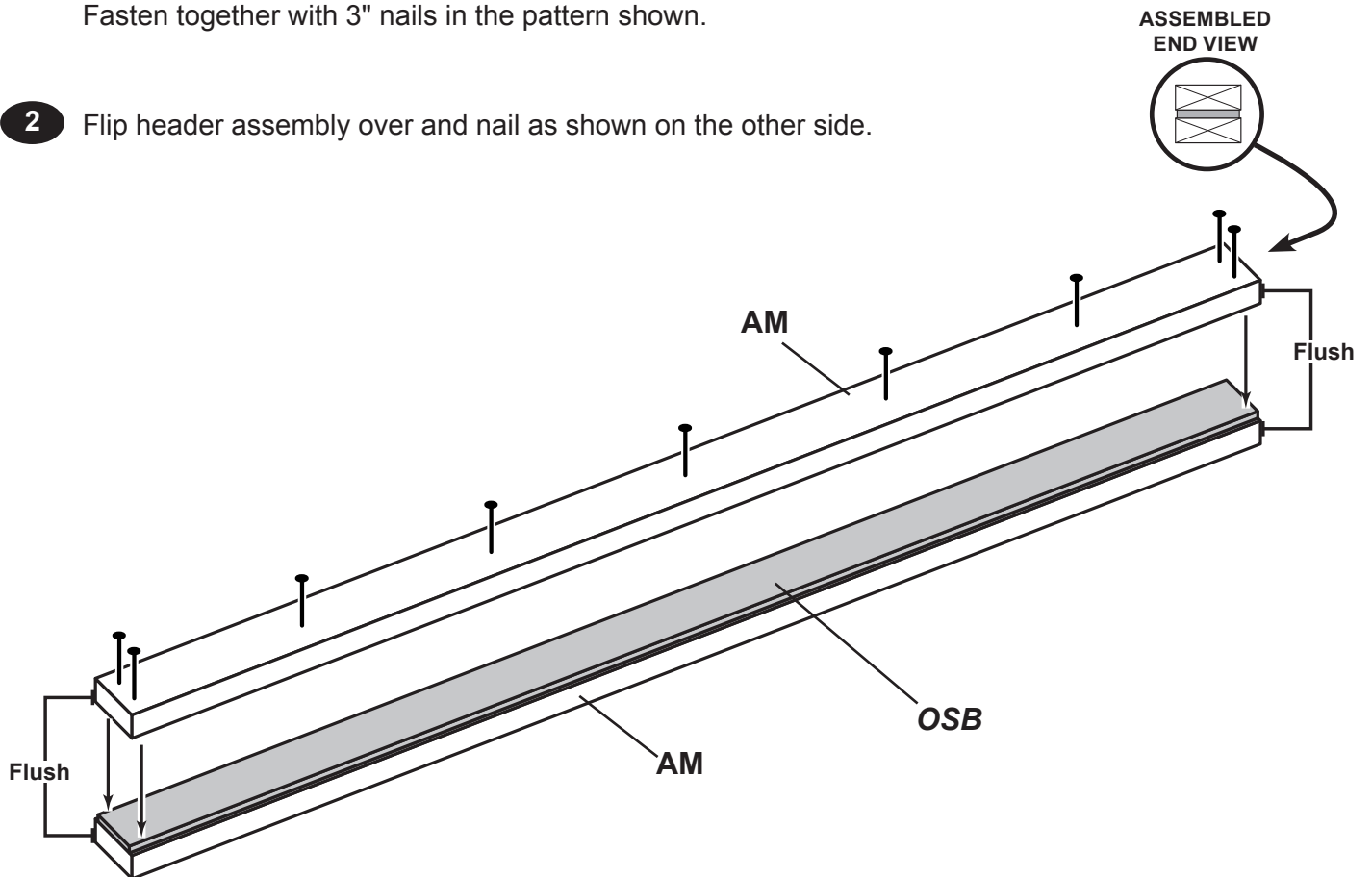

 **FINISH**

Your door header is now assembled.

WALL PANEL INSTALLATION HINTS & EXAMPLES

PARTS REQUIRED:

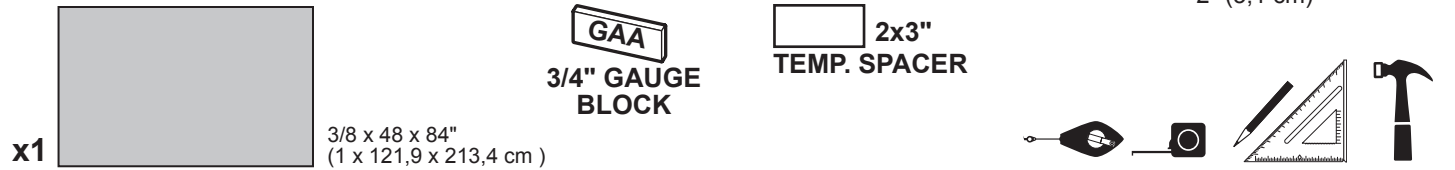

Ensure your wall is square by installing one panel and squaring frame.

Install all wall panels with the primed side facing up.

BEGIN

- 1** Place a **48" X 84"** panel on the wall frame, as shown.
 Locate the panel 1-1/2" above the top plate.
 Use a 2 x 3 as a gauge block for the 1-1/2" top overhang measurement.
 Use the gauge block to mark the 3/4" side measurement on the wall stud.
 Secure panel with (2) 2" nails in the corners (**Fig. A**).

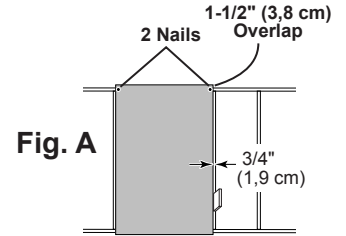

- 2** Move to the opposite end. Using the long edge of the panel as a lever, move the panel side-to-side until you have a 3/4" measurement on the wall stud.
 Secure corner with (2) 2" nails (**Fig. B**).
 Secure panel with 2" nails spaced 6" apart on edges and 12" apart inside panel.
Note the panel lip-edge/square edge orientation.

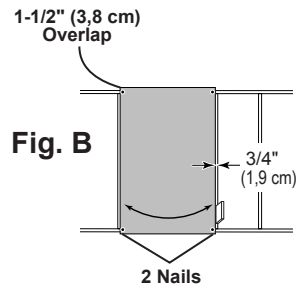

For squareness maintain 3/4" and 1-1/2" measurement along panel edge.

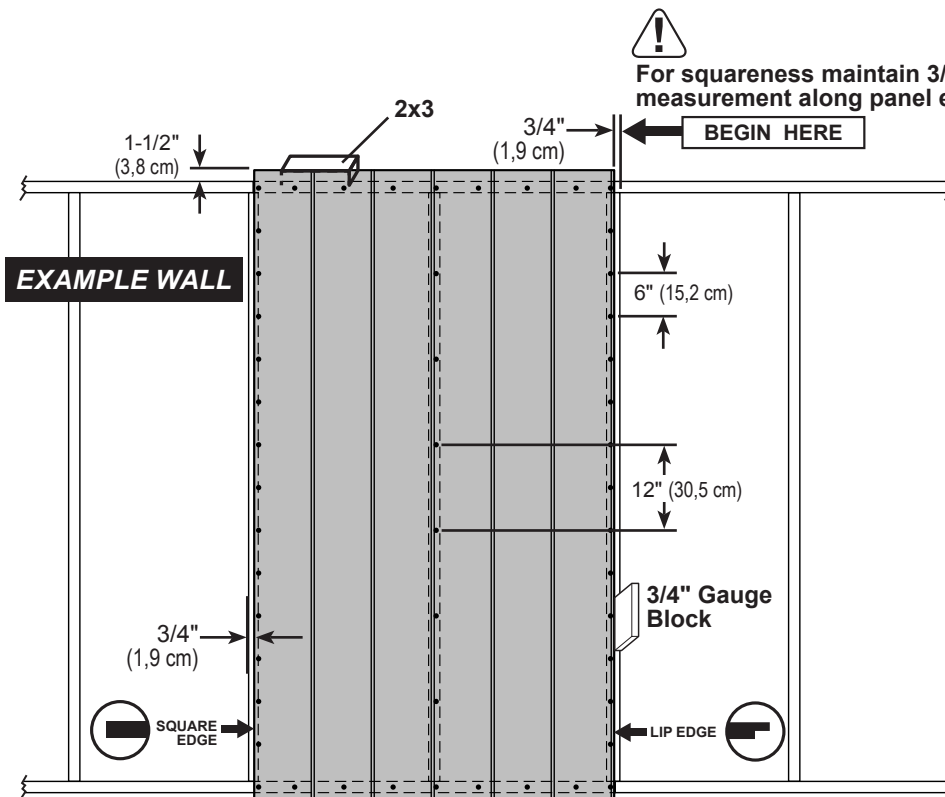

HINTS

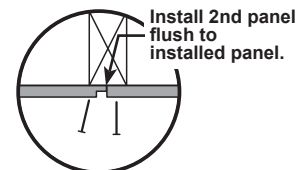
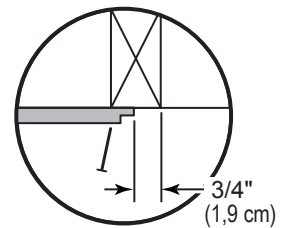

10' WALL - 01

PARTS REQUIRED: x5 **AL**

2 x 4 x 7" (5,1 x 10,2 x 17,8 cm)

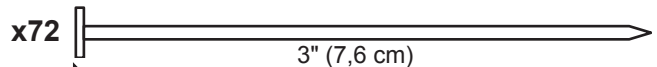

x2 **SL** 2 x 4 x 36" (5,1 x 10,2 x 91,4 cm)

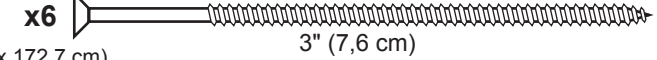

x2 **UM** 2 x 4 x 68" (5,1 x 10,2 x 172,7 cm)

x6 **AI** 2 x 4 x 78-1/2" (5,1 x 10,2 x 199,4 cm)

x2 **TO** 2 x 4 x 84" (5,1 x 10,2 x 213,4 cm)

Pre Assembled Header

x1



✓ BEGIN

- 1 Orient parts on edge on floor as shown. Measure and mark from end of boards.
Orient **Pre Assembled Header** on flat side (**Fig. A**).
Secure with (2) 3" nails at each connection and (4) 3" nails at seams.
- 2 Fasten (3) middle parts **AL** to **Pre Assembled Header** with (2) 3" screws (**Fig. B**).
Fasten (2) end **AL** to studs **AI** with (4) 3" nails at each side.
Secure parts **AL** to top plates with (2) 3" nails at each connection and (4) 3" nails at seam.

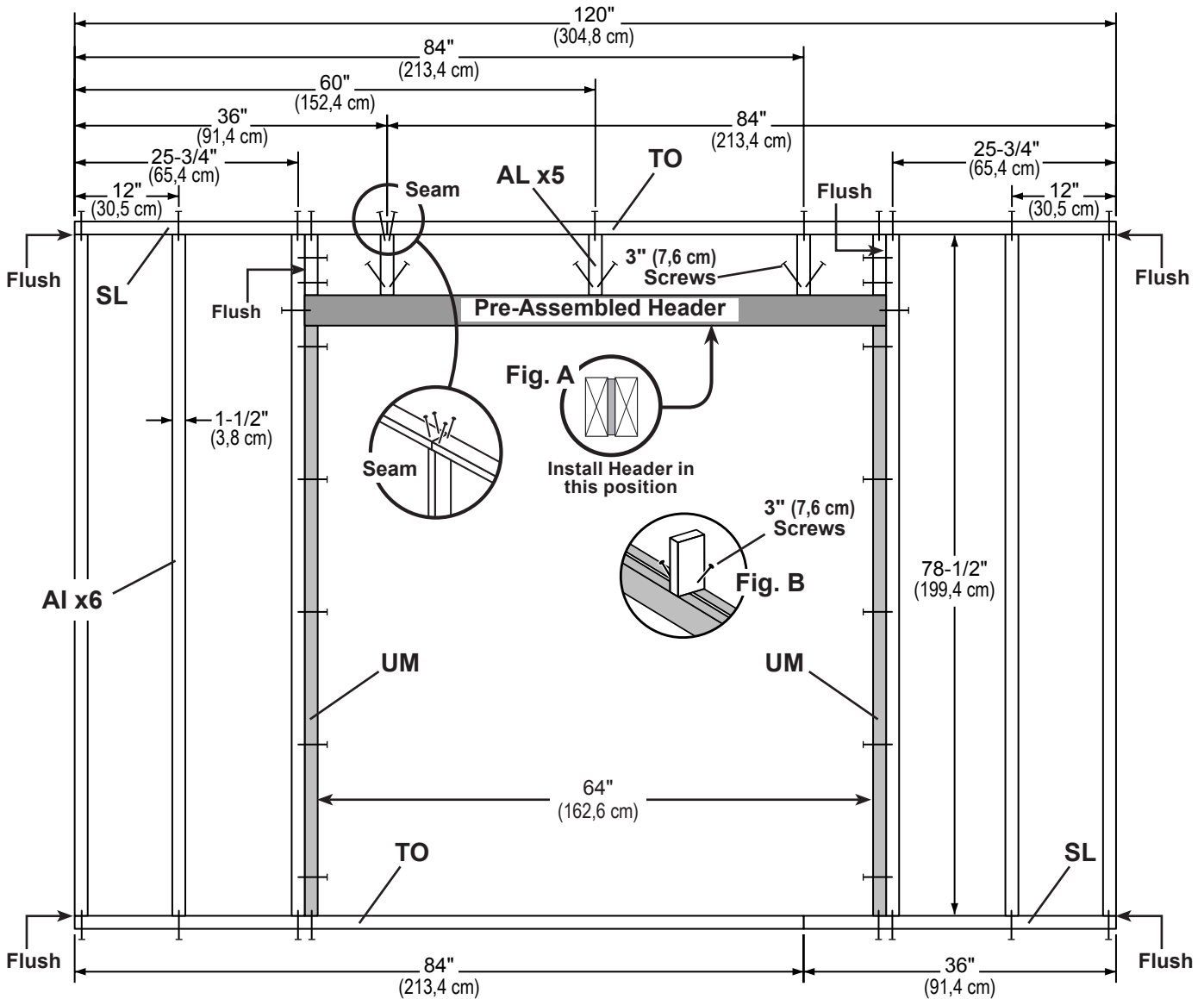

10' WALL 01

PARTS REQUIRED:

x2 11-7/8" x 84" (30,2 x 213,4 cm)

x1 x1

x2 3" (7,6 cm)

x150 2" (5,1 cm)

x1 OO Temporary Brace
69" (75,3 cm) Door Stiffener



3 Install the left panel 1-1/2" from the top plate. Use a 2x3 spacer for consistent measurement. Secure panel with 2" nails spaced 6" apart on edges.

4 Install the right panel flush to installed panel, as shown. Ensure 64" (162,8 cm) door measurement. Use part OO as a temporary brace. Secure with (2) 3" screws.

Secure panels with 2" nails spaced 6" apart on edges.

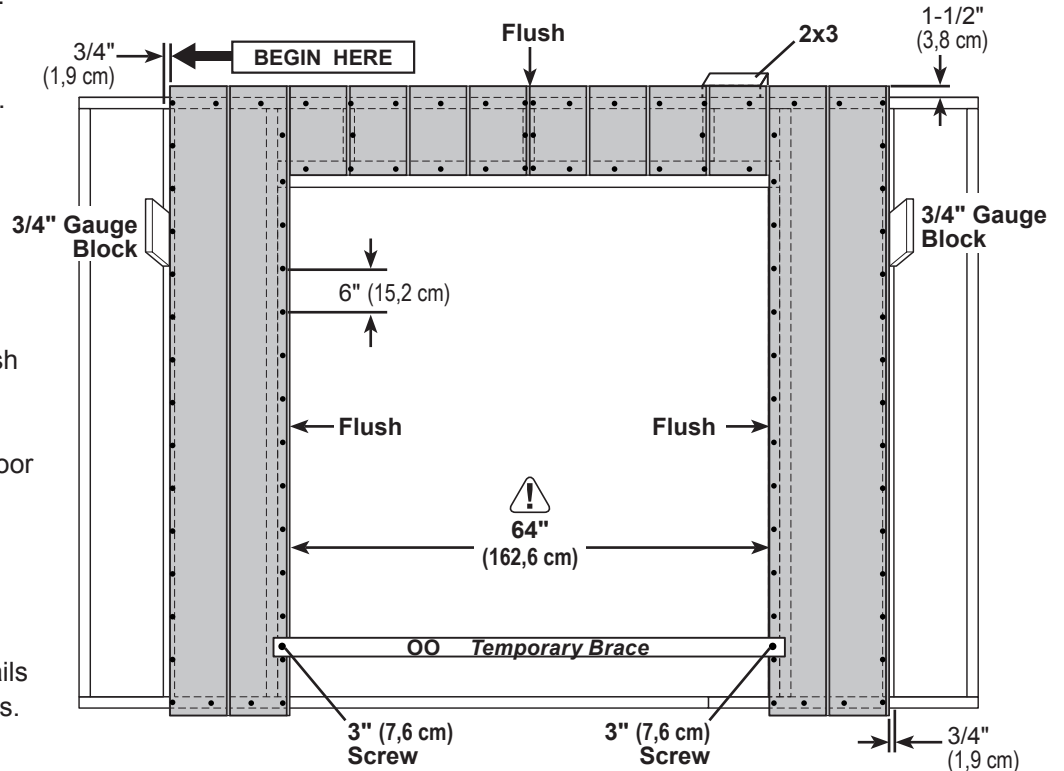

5 Install (2) 11-7/8" x 84" panels flush to installed panels and 1-1/2" from the top plate.

Secure panels with 2" nails spaced 6" apart on edges.

Note the panel lip-edge/square edge orientation.

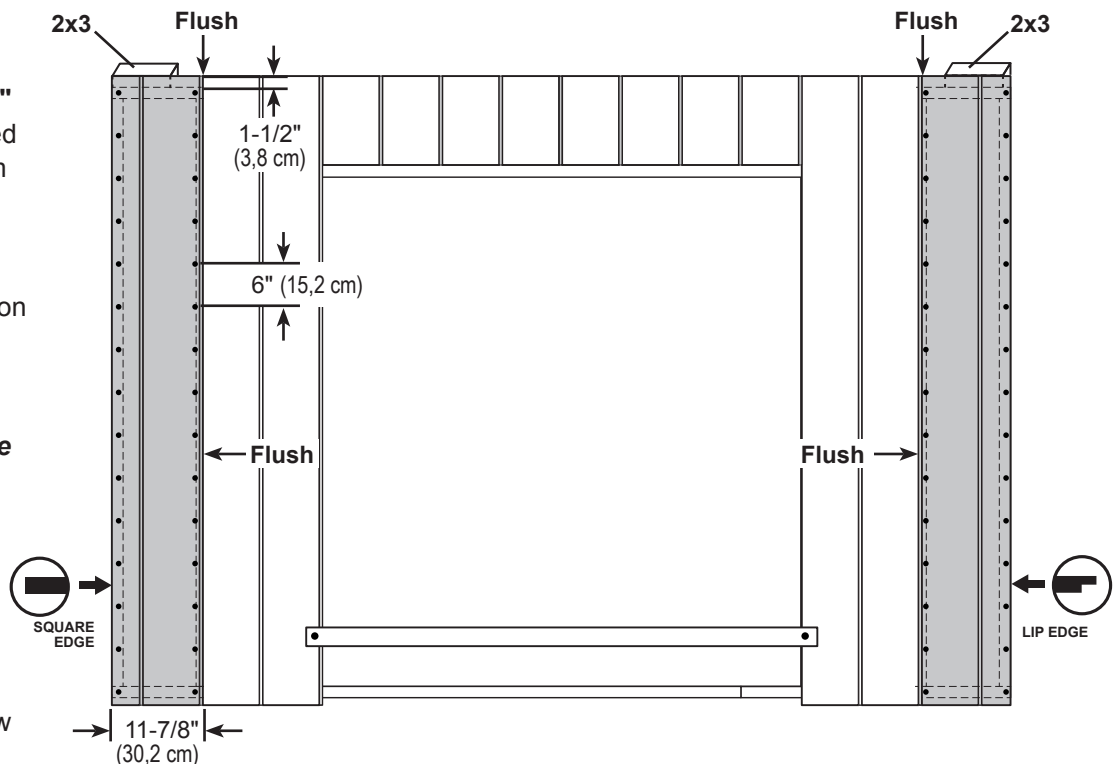

Your 10' WALL 01 is now assembled. Carefully flip the wall over.

10' WALL 02

PARTS REQUIRED:

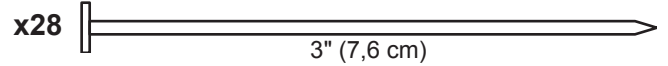

x2 **RL**
2 x 4 x 24" (5,1 x 10,2 x 61 cm)

x6 **AI**
2 x 4 x 78-1/2" (5,1 x 10,2 x 199,4 cm)

x2 **TP**
2 x 4 x 96" (5,1 x 10,2 x 243,8 cm)



✓ BEGIN

- 1 Orient parts on edge on floor as shown. Measure and mark from end of boards.
Secure with (2) 3" nails at each connection and (4) 3" nails at seams.

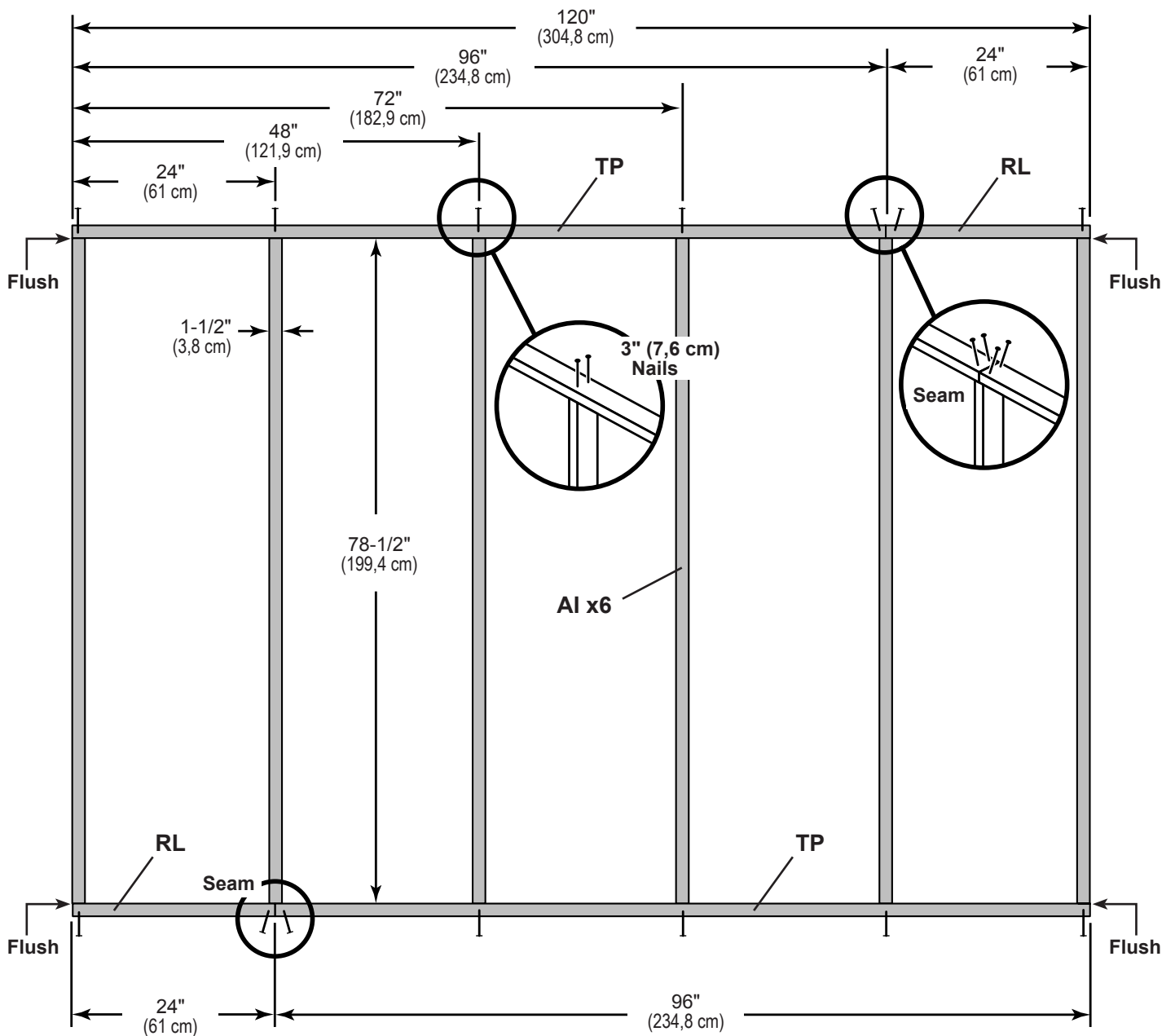
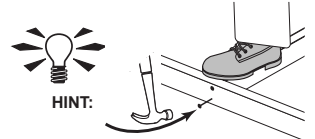

10' WALL 02

PARTS REQUIRED:

- x1  23-7/8" x 84"
(60,6 x 213,4 cm)
- x2  48 x 84"
(121,9 x 213,4 cm)

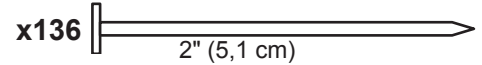

2
Install 48" x 84" panel 1-1/2" from the top plate.

Use a 2x3 spacer for consistent measurement.

Secure panel with 2" nails spaced 6" apart on edges and 12" inside panel.

Note the panel lip-edge/square edge orientation.

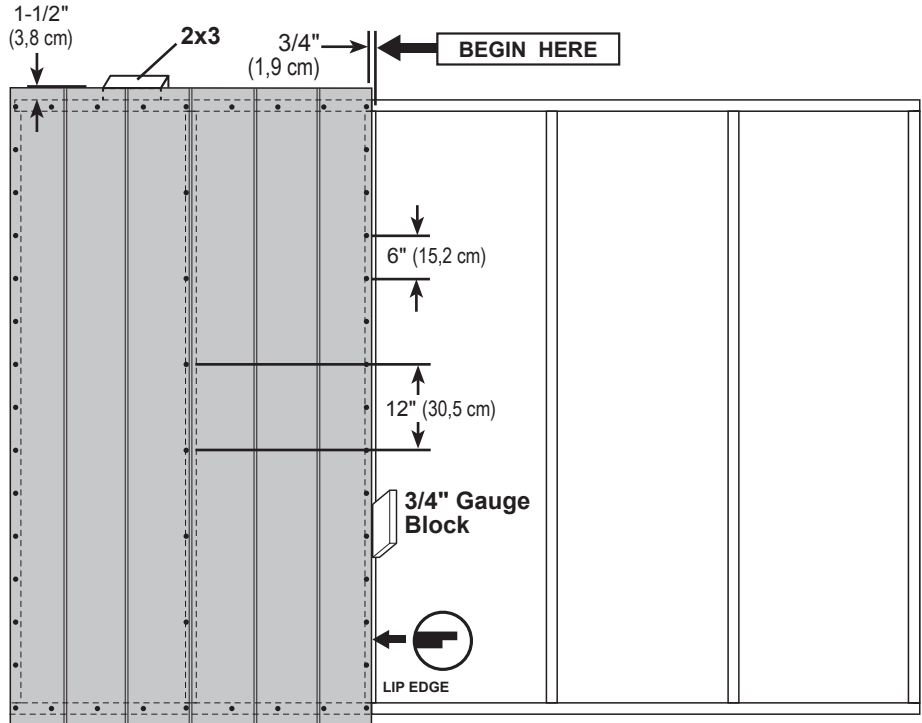

3
Install the 48" x 84" and (2) 23-7/8" x 84" panels flush to installed panels.

Locate panels 1-1/2" from the top plate.

Secure with 2" nails spaced 6" apart on edges and 12" apart inside panel.

Note the panel lip-edge/square edge orientation.

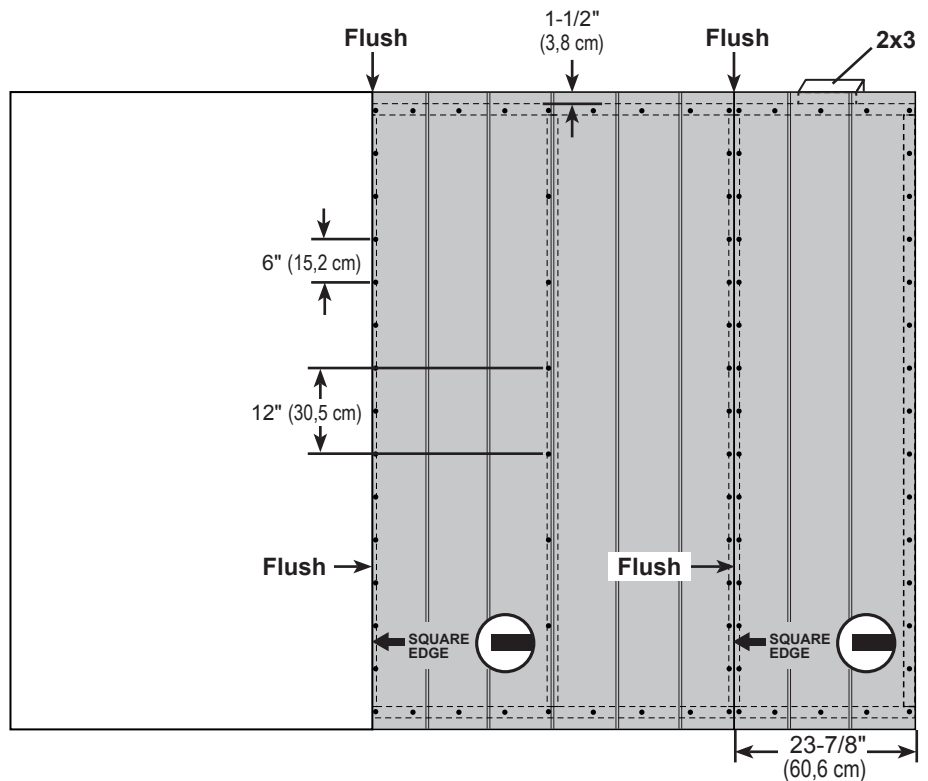

Your 10' WALL 02 is now assembled. Carefully flip the wall over.

10' WALL 03

PARTS REQUIRED:

x2 **SL**
2 x 4 x 36" (5,1 x 10,2 x 91,4 cm)

x7 **AI**
2 x 4 x 78-1/2" (5,1 x 10,2 x 199,4 cm)

x2 **TO**
2 x 4 x 84" (5,1 x 10,2 x 213,4 cm)

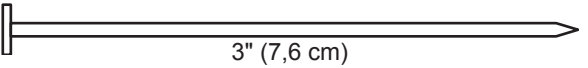
x32  3" (7,6 cm)

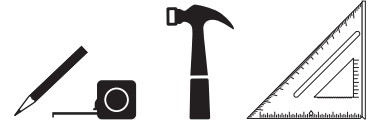

✓ BEGIN

- 1 Orient parts on edge on floor as shown. Measure and mark from end of boards.
Secure with (2) 3" nails at each connection and (4) 3" nails at seams.

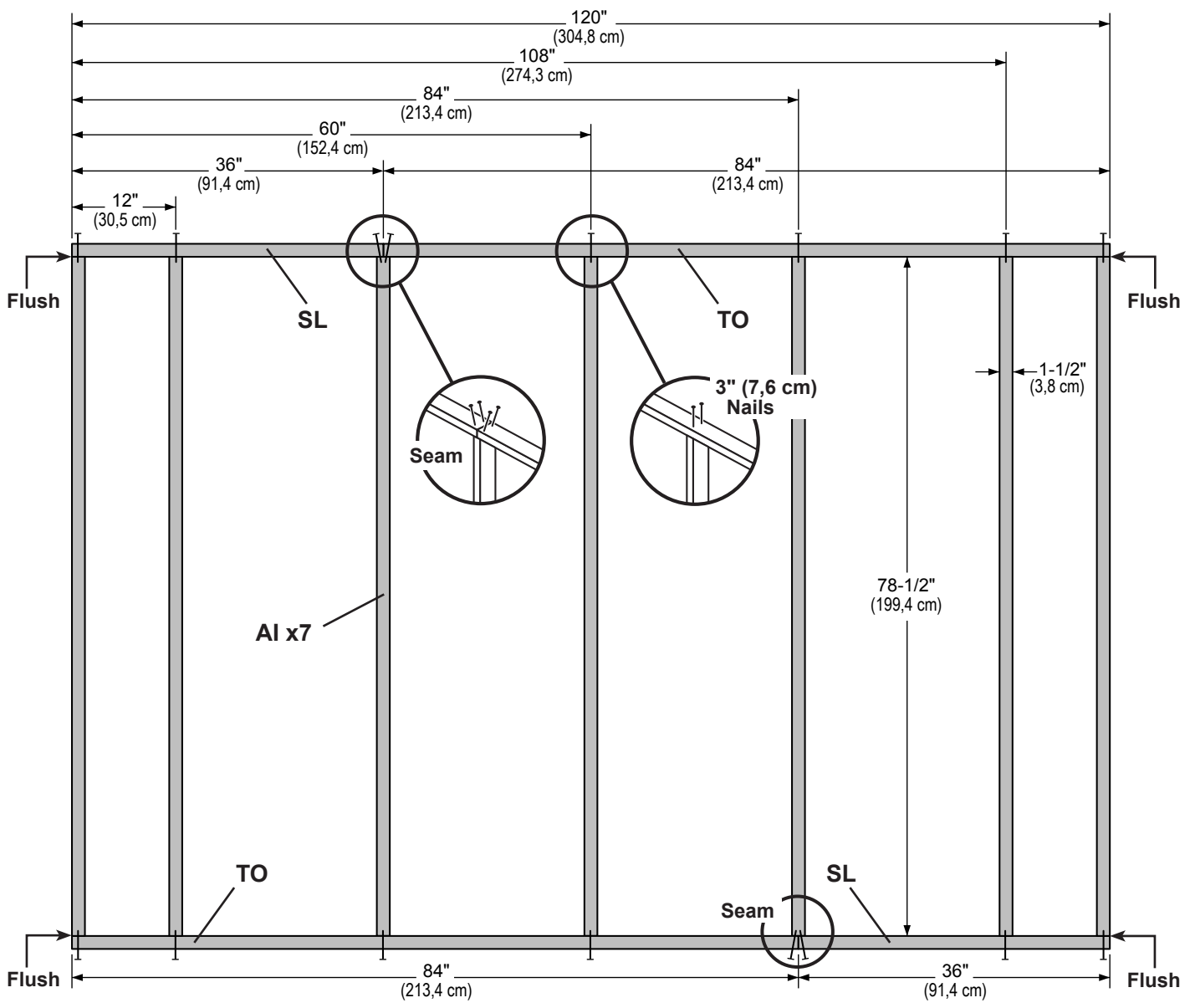

10' WALL 03

PARTS REQUIRED:

x2 (x1 Left & x1 Right)
 11-7/8" x 84" (30,2 x 213,4 cm)

x2 48 x 84"
 (121,9 x 213,4 cm)

x164 2" (5,1 cm)



2

Install 48" x 84" panel 1-1/2" from the top plate.

Use a 2x3 spacer for consistent measurement.

Secure panel with 2" nails spaced 6" apart on edges and 12" inside panel.

Note the panel lip-edge/square edge orientation.

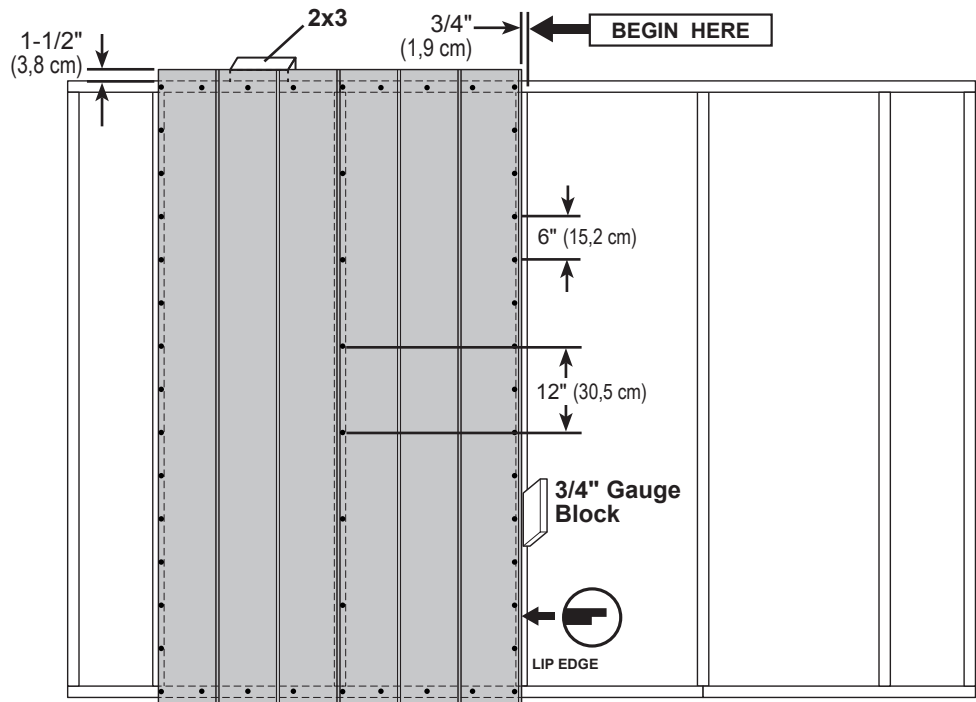

3

Install the 48" x 84" and (2) 11-7/8" x 84" panels flush to installed panels.

Locate panels 1-1/2" from the top plate.

Secure with 2" nails spaced 6" apart on edges and 12" apart inside panel.

Note the panel lip-edge/square edge orientation.

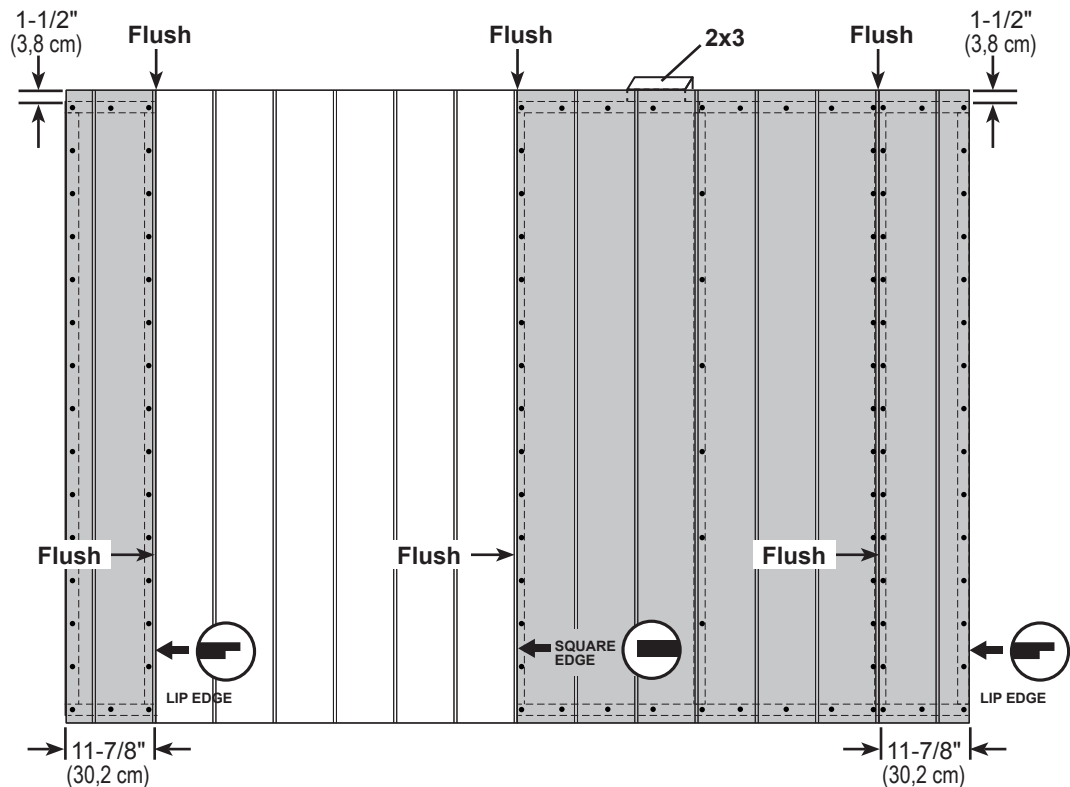

Your 10' WALL 03 is now assembled.

Carefully flip the wall over.

12' WALL 04

PARTS REQUIRED:

- x1 **HVC**
2 x 4 x 44-3/8" (5,1 x 10,2 x 112,7 cm)
- x1 **TJ**
2 x 4 x 92-5/8" (5,1 x 10,2 x 235,3 cm)
- x2 **YFA**
2 x 4 x 68-1/2" (5,1 x 10,2 x 174 cm)
- x5 **AI**
2 x 4 x 78-1/2" (5,1 x 10,2 x 199,4 cm)

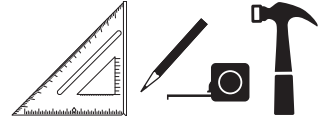
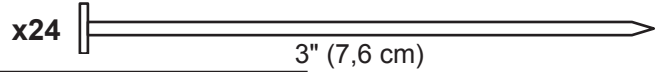

✓ BEGIN

- 1 Orient parts on edge on floor. Measure and mark from end of boards.
Secure with (2) 3" nails at each connection and (4) 3" nails at seams.

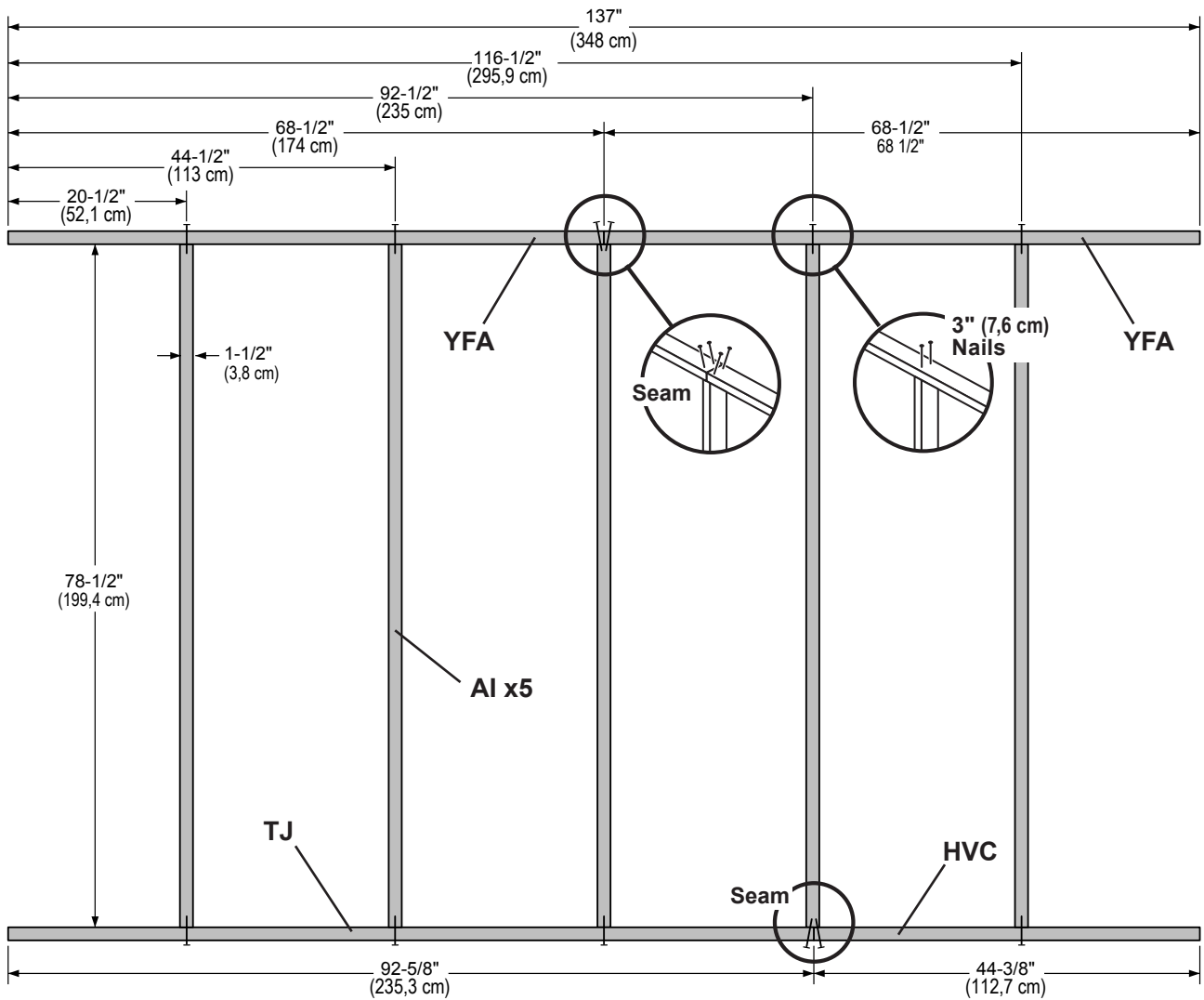
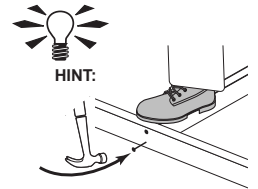

12' WALL 04

PARTS REQUIRED:

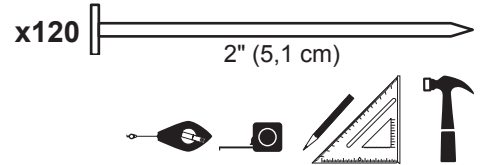

2
Install 48" x 84" panel 1-1/2" from the top plate.

Use a 2x3 spacer for consistent measurement.

Secure panel with 2" nails spaced 6" apart on edges and 12" inside panel.

Note the panel lip-edge/square edge orientation.

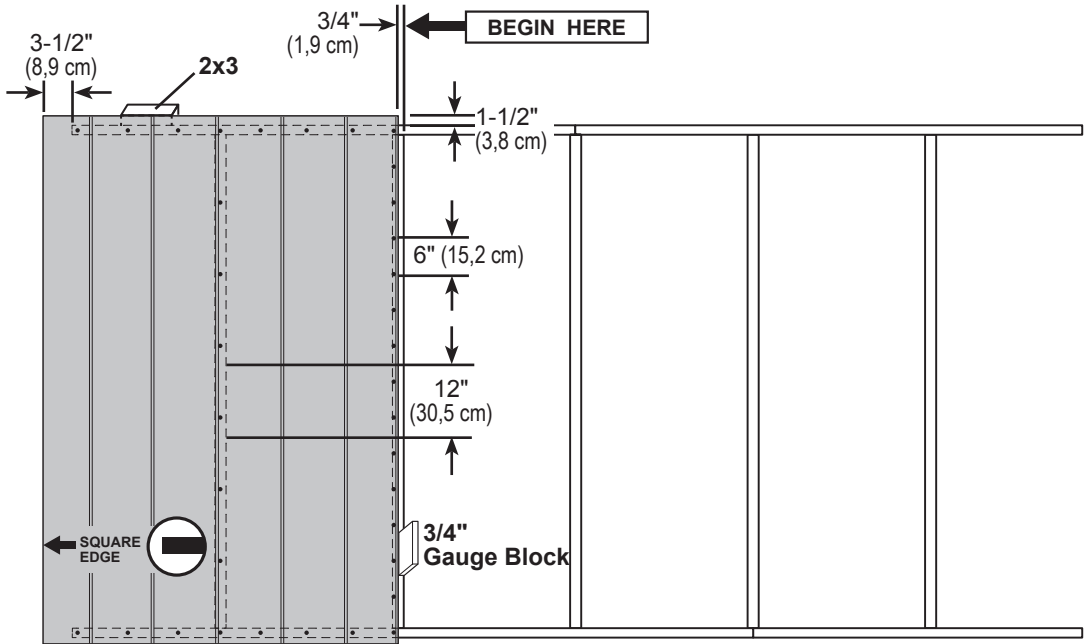

3
Install (2) 48" x 84" panels flush to installed panels.

Locate panels 1-1/2" from the top plate.

Secure with 2" nails spaced 6" apart on edges and 12" apart inside panel.

Note the panel lip-edge/square edge orientation.

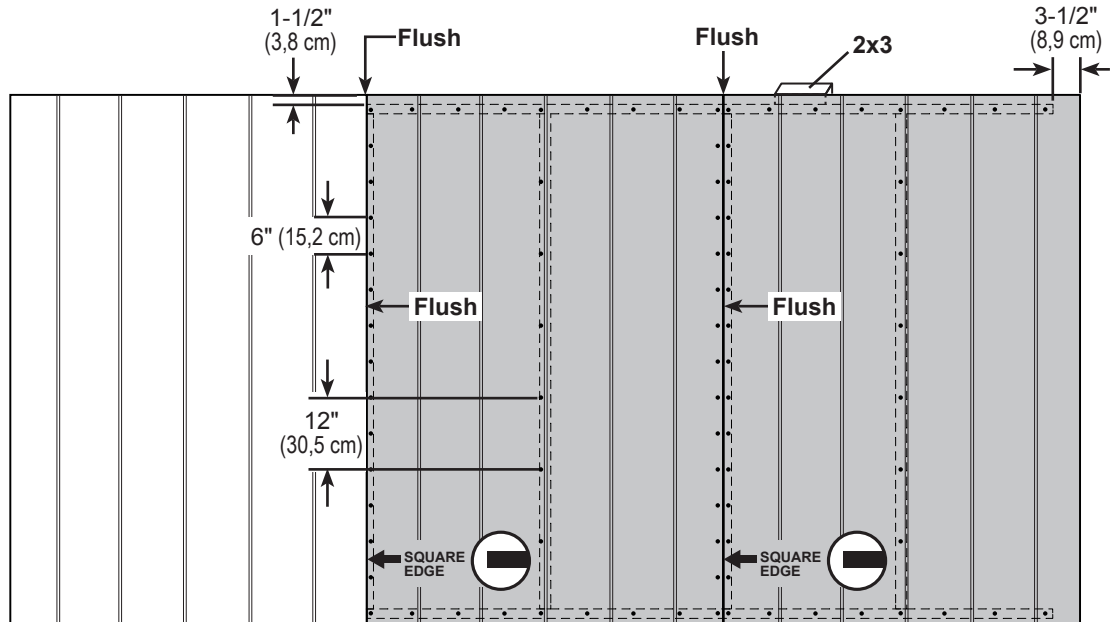

Your 12' WALL 04 is now assembled.

Carefully flip the wall over.

12' WALL - 05

PARTS REQUIRED:

x1 **HVC**
2 x 4 x 44-3/8" (5,1 x 10,2 x 112,7 cm)

x1 **TJ**
2 x 4 x 92-5/8" (5,1 x 10,2 x 235,3 cm)

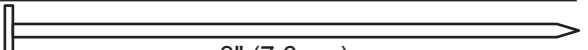
x24  3" (7,6 cm)

x2 **YFA**
2 x 4 x 68-1/2" (5,1 x 10,2 x 174 cm)

x5 **AI**
2 x 4 x 78-1/2" (5,1 x 10,2 x 199,4 cm)

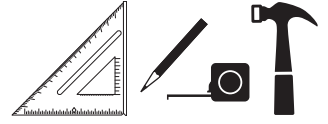

✓ BEGIN

- 1 Orient parts on edge on floor. Measure and mark from end of boards. Secure with (2) 3" nails at each connection and (4) 3" nails at seams.

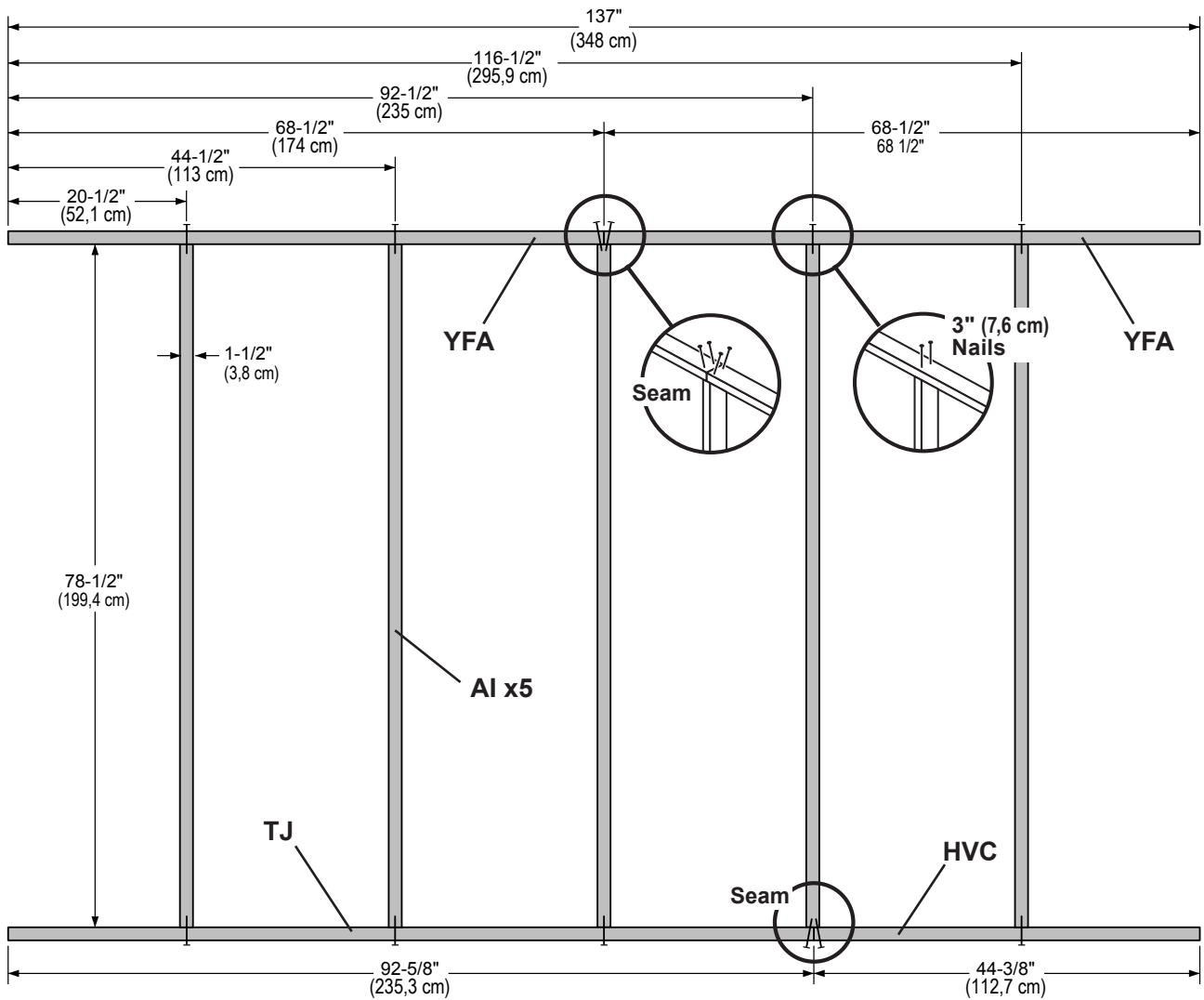
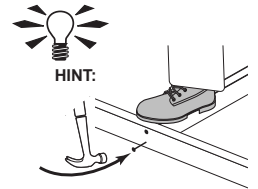

12' WALL 05

PARTS REQUIRED:

x1



23-7/8" x 84"
(60,6 x 213,4 cm)

x3

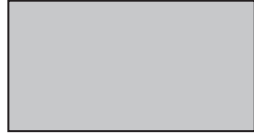

48 x 84"
(121,9 x 213,4 cm)

x142

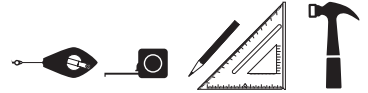
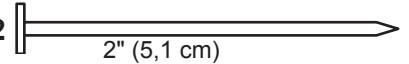

2

Install 48" x 84" panel 1-1/2" from the top plate.

Use a 2x3 spacer for consistent measurement.

Secure panel with 2" nails spaced 6" apart on edges and 12" inside panel.

Note the panel lip-edge/square edge orientation.

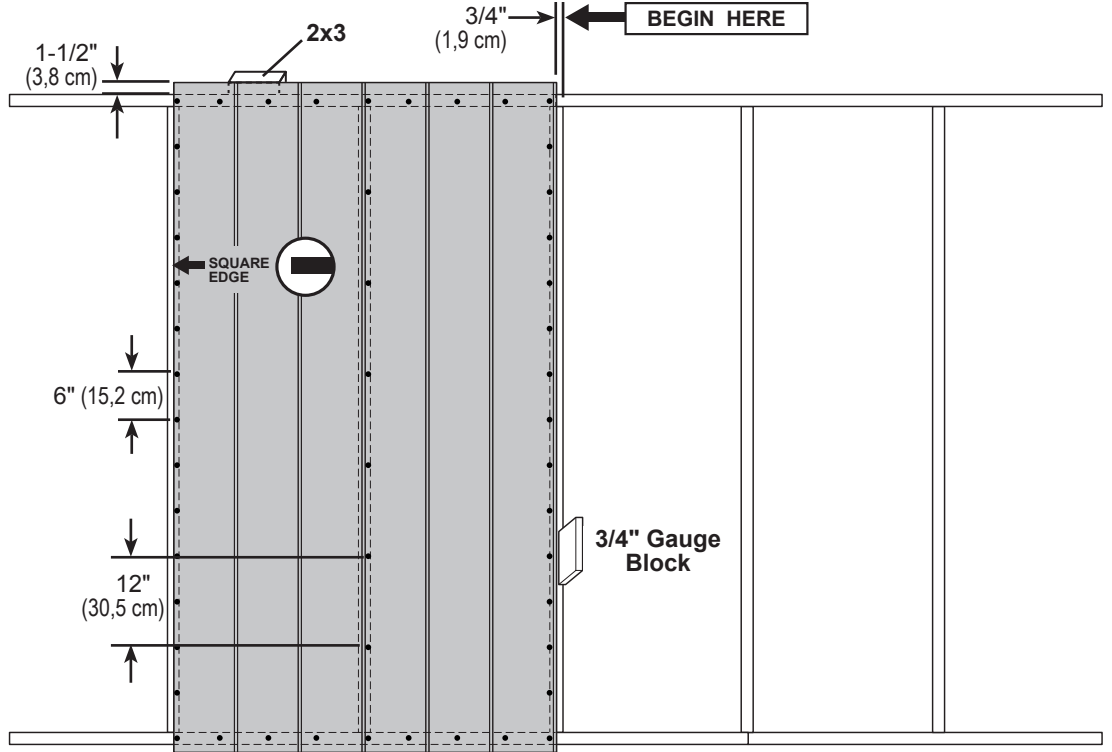

3

Install 48" x 84" and (2) 23-7/8" x 84" panels flush to installed panels.

Locate panels 1-1/2" from the top plate.

Secure with 2" nails spaced 6" apart on edges and 12" apart inside panel.

Note the panel lip-edge/square edge orientation.

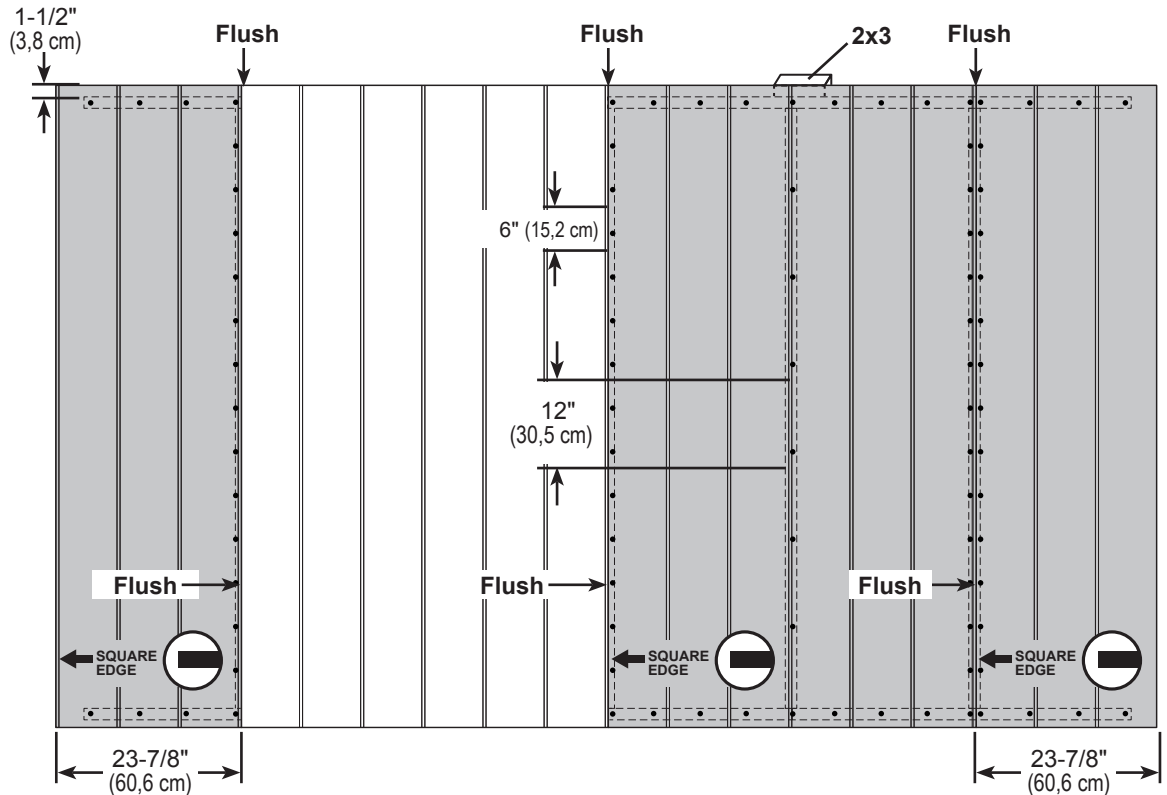

FINISH

Your 12' WALL 05 is now assembled.

Carefully flip the wall over.

12' WALL 06

PARTS REQUIRED: x5 **AL**

- x1 **HVC** 2 x 4 x 44-3/8" (5,1 x 10,2 x 112,7 cm)
- x2 **UM** 2 x 4 x 68" (5,1 x 10,2 x 172,7 cm)
- x4 **AI** 2 x 4 x 78-1/2" (5,1 x 10,2 x 199,4 cm)
- x1 **TJ** 2 x 4 x 92-5/8" (5,1 x 10,2 x 235,3 cm)
- x1 **Pre Assembled Header**
- x2 **YFA** 2 x 4 x 68-1/2" (5,1 x 10,2 x 174 cm)

- x64 3" (7,6 cm)
- x6 3" (7,6 cm)



✓ BEGIN

- 1** Orient parts on edge on floor as shown. Measure and mark from end of boards. Orient **Pre Assembled Header** on flat side (**Fig. A**). Secure with (2) 3" nails at each connection and (4) 3" nails at seams.
- 2** Fasten (3) middle parts **AL** to **Pre Assembled Header** with (2) 3" screws (**Fig. B**). Fasten (2) end **AL** to studs **AI** with (4) 3" nails at each side. Secure parts **AL** to top plates with (2) 3" nails at each connection and (4) 3" nails at seam.

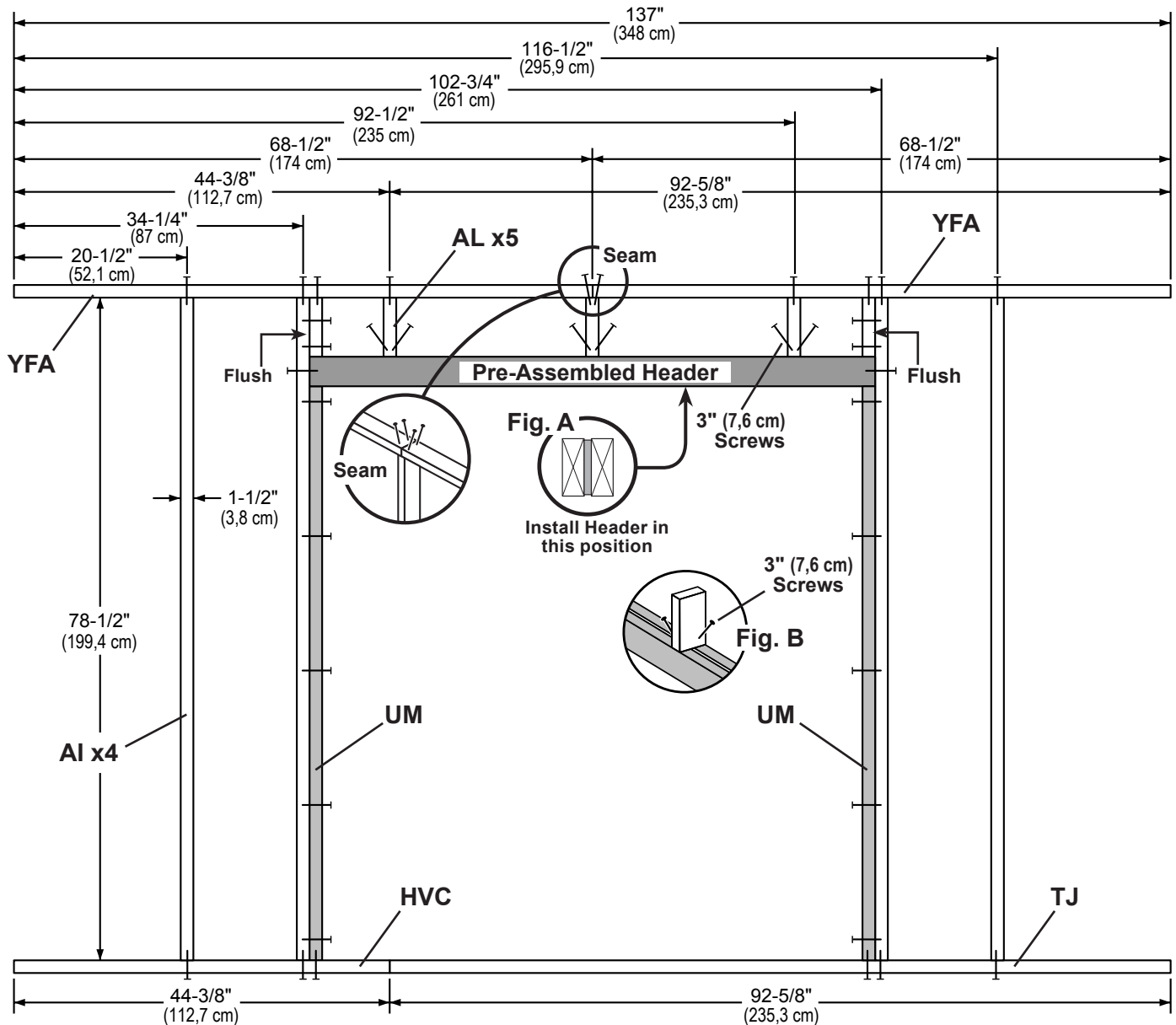

12' WALL 06

PARTS REQUIRED:

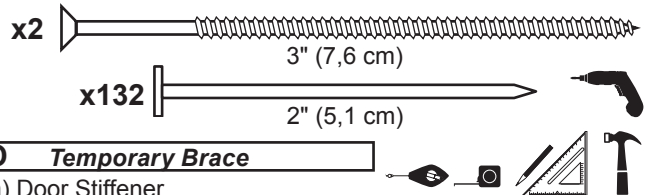
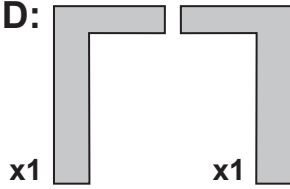
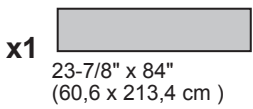

3

Install the left panel 1-1/2" from the top plate. Use a 2x3 spacer for consistent measurement.

Secure panel with 2" nails spaced 6" apart on edges.

4

Install the right panel flush to installed panel, as shown.

Ensure 64" (162,8 cm) door measurement.

Use part OO as a temporary brace. Secure with with (2) 3" screws.

Secure panel with 2" nails spaced 6" apart on edges.

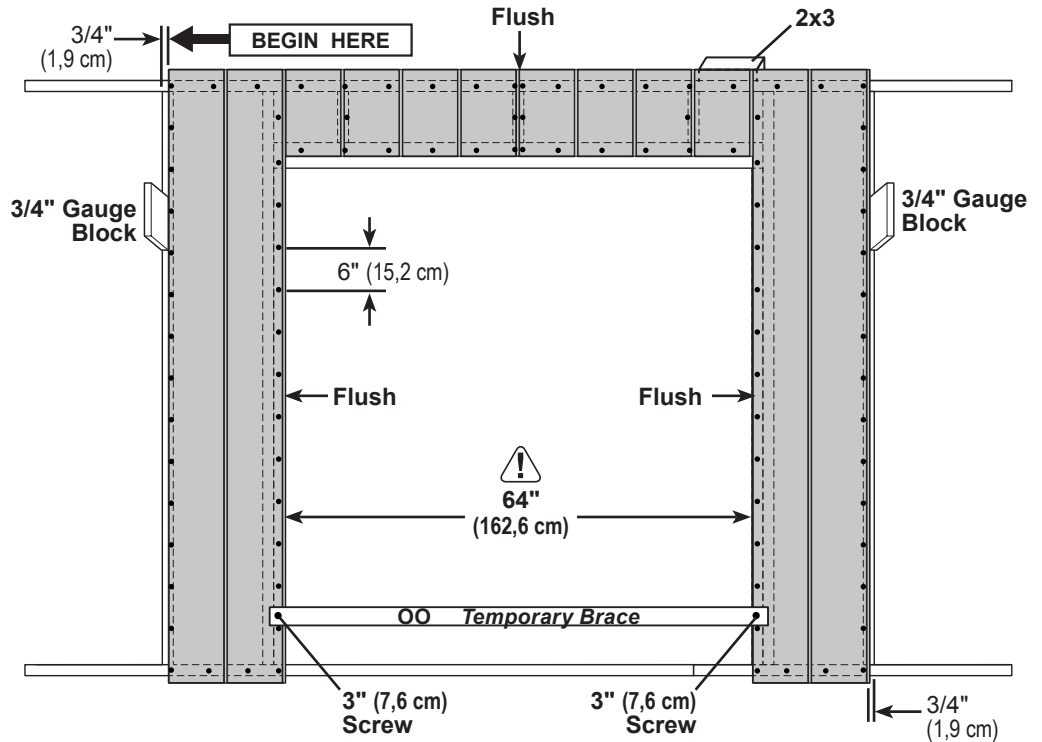

5

Install (2) 23-7/8" x 84" panels flush to installed panels and 1-1/2" from the top plate.

Secure panels with 2" nails spaced 6" apart on edges.

Note the panel lip-edge/square edge orientation.

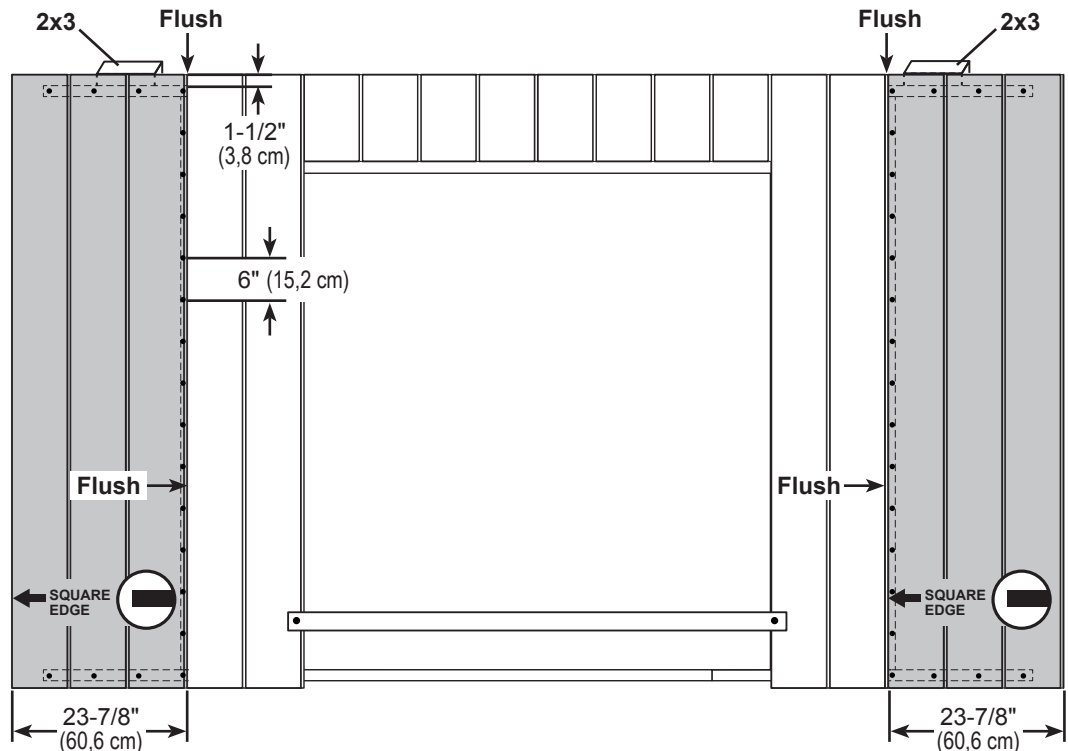

Your 12' WALL 06 is now assembled. Carefully flip the wall over.

12' WALL 07

PARTS REQUIRED:

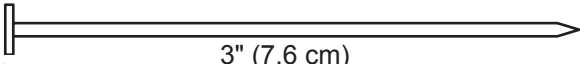
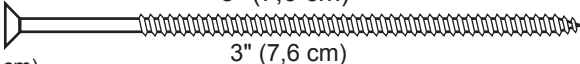
x5	AL	2 x 4 x 7" (5,1 x 10,2 x 17,8 cm)	x66		3" (7,6 cm)
x1	HVC	2 x 4 x 44-3/8" (5,1 x 10,2 x 112,7 cm)	x6		3" (7,6 cm)
x2	UM	2 x 4 x 68" (5,1 x 10,2 x 172,7 cm)			
x4	AI	2 x 4 x 78-1/2" (5,1 x 10,2 x 199,4 cm)			
x1	TJ	2 x 4 x 92-5/8" (5,1 x 10,2 x 235,3 cm)			
x1	Pre Assembled Header		x2	YFA	2 x 4 x 68-1/2" (5,1 x 10,2 x 174 cm)



BEGIN

- 1 Orient parts on edge on floor as shown. Measure and mark from end of boards.
Orient **Pre Assembled Header** on flat side (**Fig. A**).
Secure with (2) 3" nails at each connection and (4) 3" nails at seams.
- 2 Fasten (3) middle parts **AL** to **Pre Assembled Header** with (2) 3" screws (**Fig. B**).
Fasten (2) end **AL** to studs **AI** with (4) 3" nails at each side.
Secure parts **AL** to top plates with (2) 3" nails at each connection and (4) 3" nails at seam.

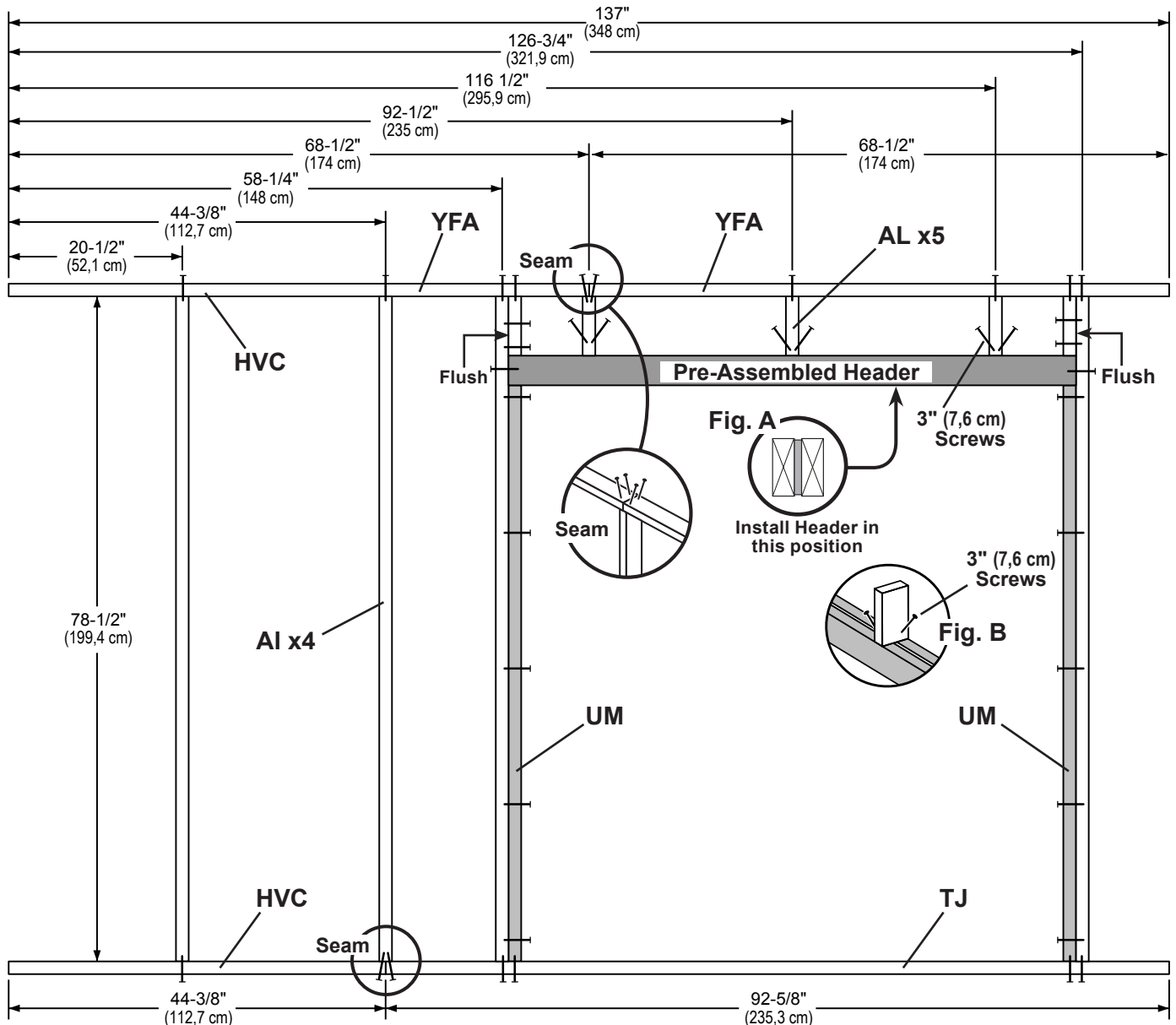

12' WALL 07

PARTS REQUIRED:

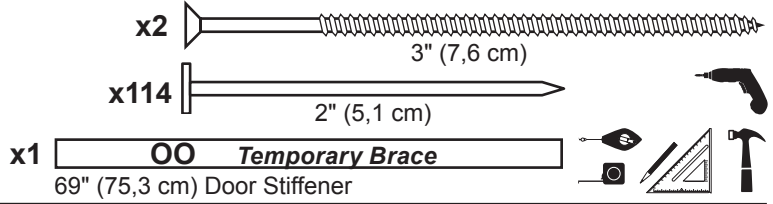
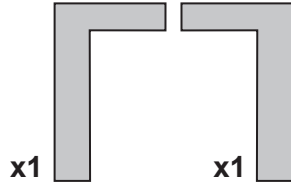
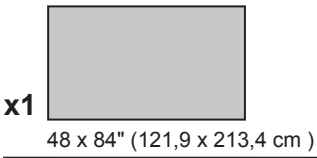

3

Install the left panel 1-1/2" from the top plate. Use a 2x3 spacer for consistent measurement.

Secure panel with 2" nails spaced 6" apart on edges.

4

Install the right panel flush to installed panel, as shown. Ensure 64" (162,8 cm) door measurement. Use part OO as a temporary brace. Secure with with (2) 3" screws.

Secure panel with 2" nails spaced 6" apart on edges.

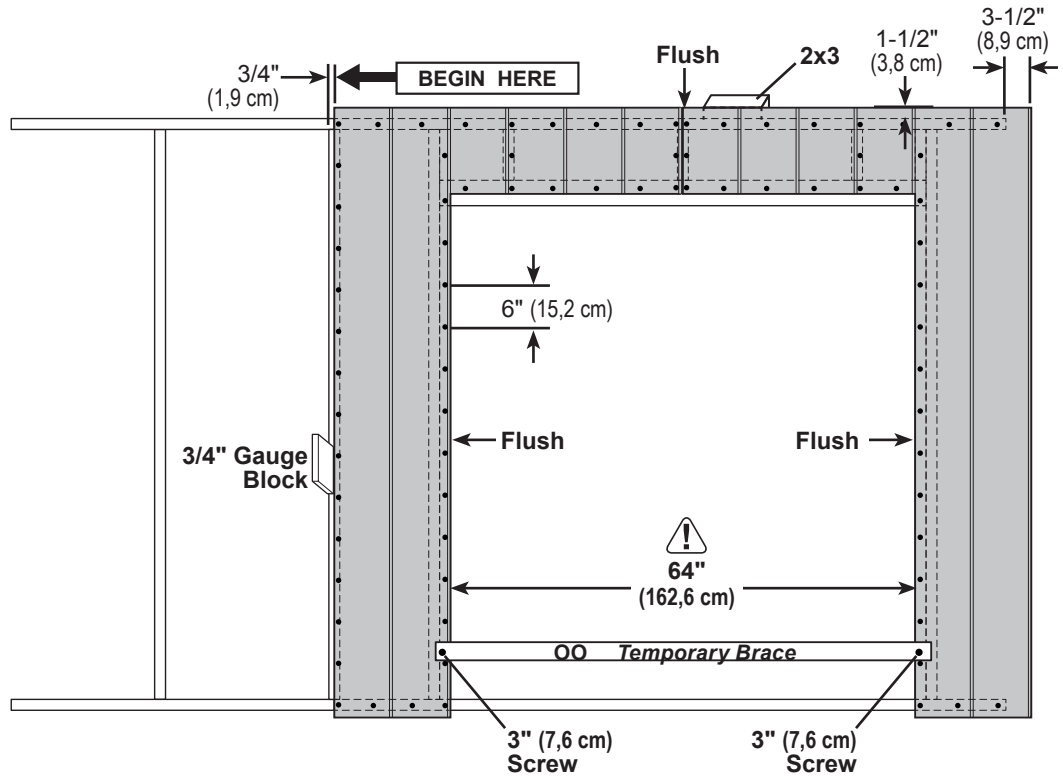

5

Install 48" x 84" panel flush to installed panel and 1-1/2" from the top plate.

Secure panels with 2" nails spaced 6" apart on edges.

Note the panel lip-edge/square edge orientation.

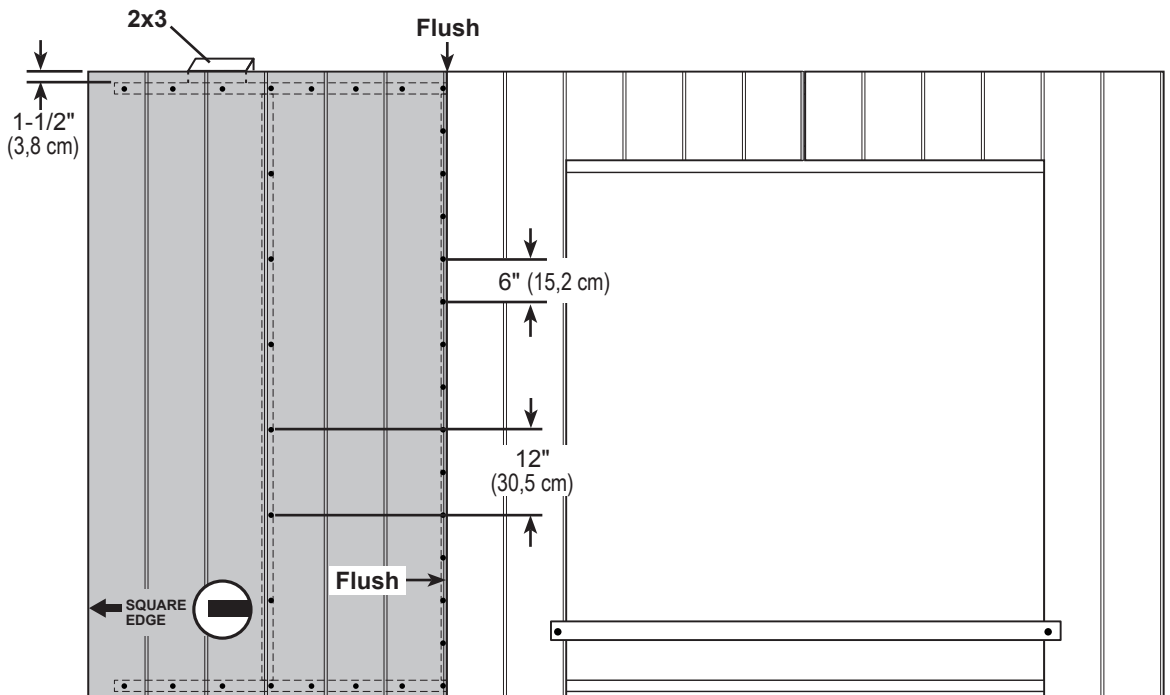

Your 12' WALL 07 is now assembled. Carefully flip the wall over.

16' WALL 08

PARTS REQUIRED:

x1 **HVC** 2 x 4 x 44-3/8" (5,1 x 10,2 x 112,7 cm)

x2 **SP** 2 x 4 x 48" (5,1 x 10,2 x 121,9 cm)

x7 **AI** 2 x 4 x 78-1/2" (5,1 x 10,2 x 199,4 cm)

x1 **TJ** 2 x 4 x 92-5/8" (5,1 x 10,2 x 235,3 cm)

x36 **3"** (7,6 cm)

x2 **YFA** 2 x 4 x 68-1/2" (5,1 x 10,2 x 174 cm)

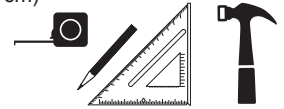

✓ BEGIN

- 1 Orient parts on edge on floor. Measure and mark from end of boards.
Secure with (2) 3" nails at each connection and (4) 3" nails at seams.

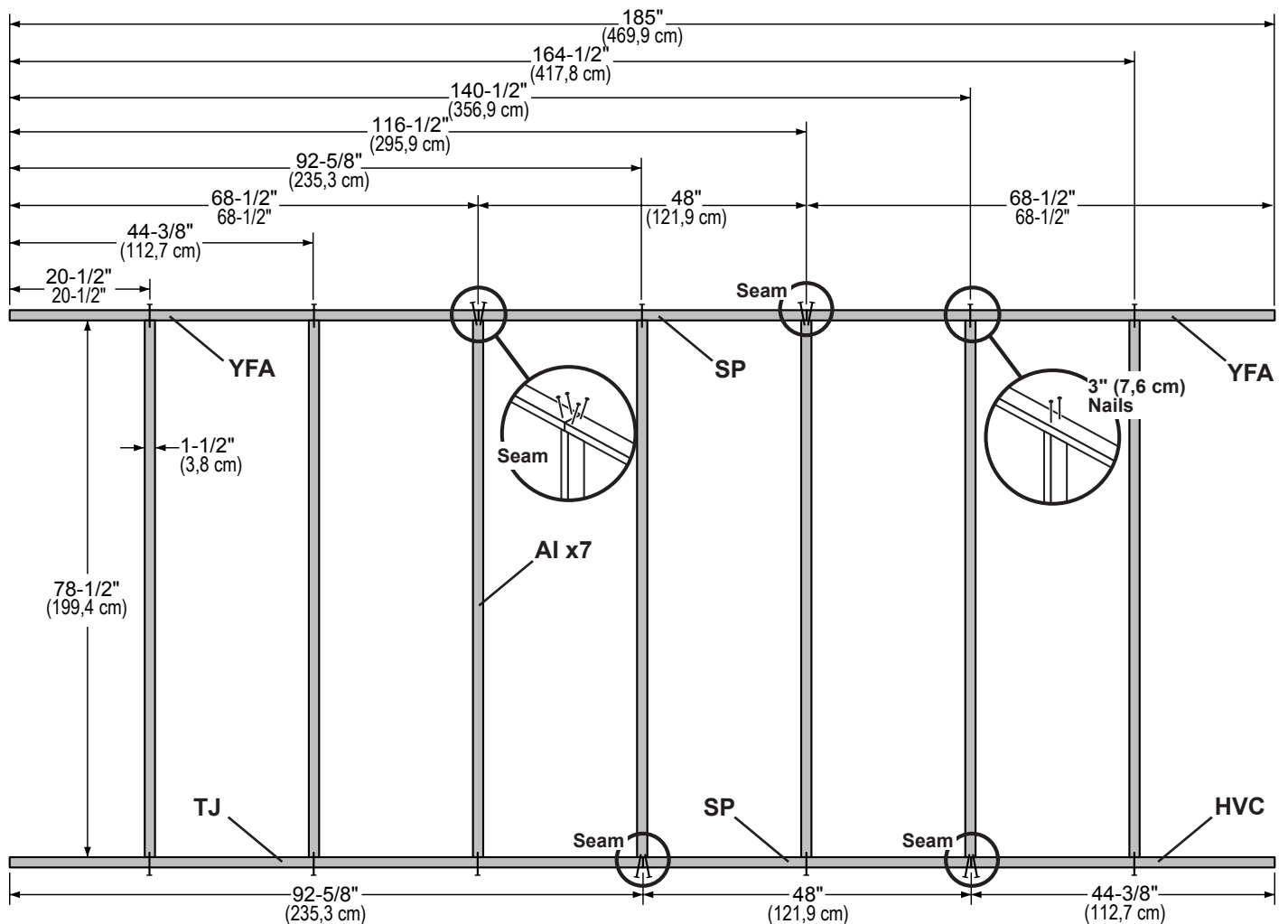
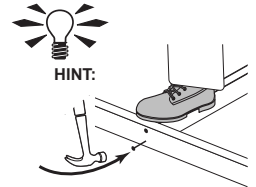

16' WALL 08

PARTS REQUIRED:

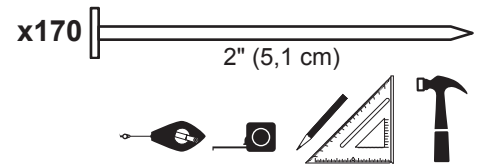
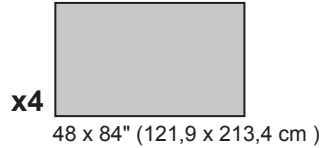

2

Install 48" x 84" panel 1-1/2" from the top plate.

Use a 2x3 spacer for consistent measurement.

Secure panel with 2" nails spaced 6" apart on edges and 12" inside panel.

Note the panel lip-edge/square edge orientation.

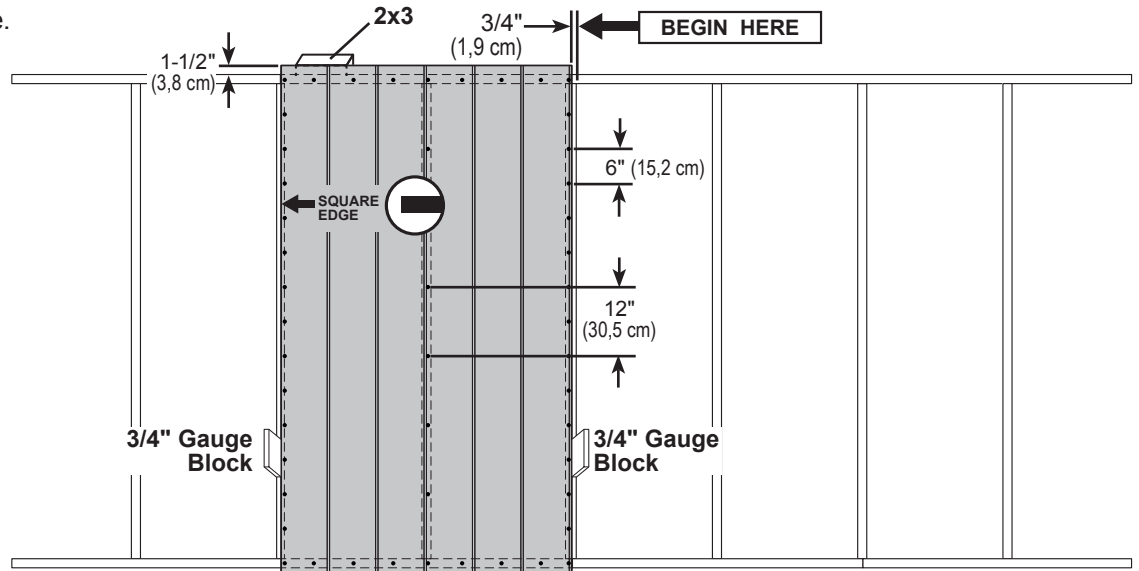

3

Install (3) 48" x 84" panels flush to installed panels.

Locate panels 1-1/2" from the top plate.

Secure with 2" nails spaced 6" apart on edges and 12" apart inside panel.

Note the panel lip-edge/square edge orientation.

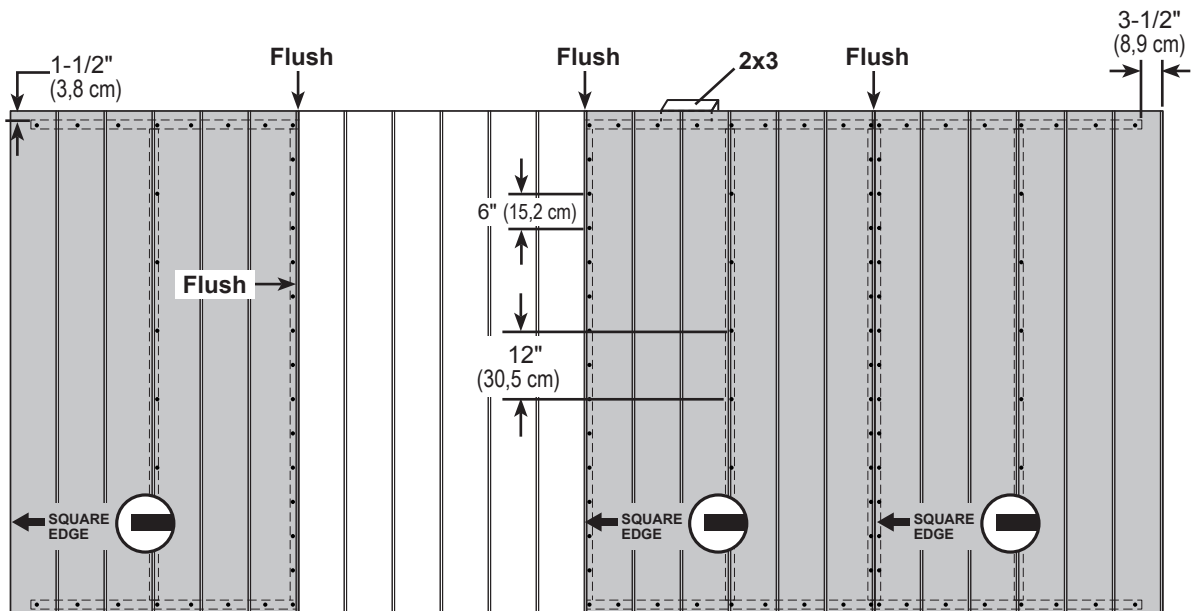

Your 16' WALL 08 is now assembled.

Carefully flip the wall over.

16' WALL 09

PARTS REQUIRED:

x1 **HVC** 2 x 4 x 44-3/8" (5,1 x 10,2 x 112,7 cm)

x2 **SP** 2 x 4 x 48" (5,1 x 10,2 x 121,9 cm)

x7 **AI** 2 x 4 x 78-1/2" (5,1 x 10,2 x 199,4 cm)

x1 **TJ** 2 x 4 x 92-5/8" (5,1 x 10,2 x 235,3 cm)

x36 3" (7,6 cm)

x2 **YFA** 2 x 4 x 68-1/2" (5,1 x 10,2 x 174 cm)

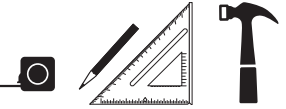

✓ BEGIN

- 1 Orient parts on edge on floor. Measure and mark from end of boards.
Secure with (2) 3" nails at each connection and (4) 3" nails at seams.

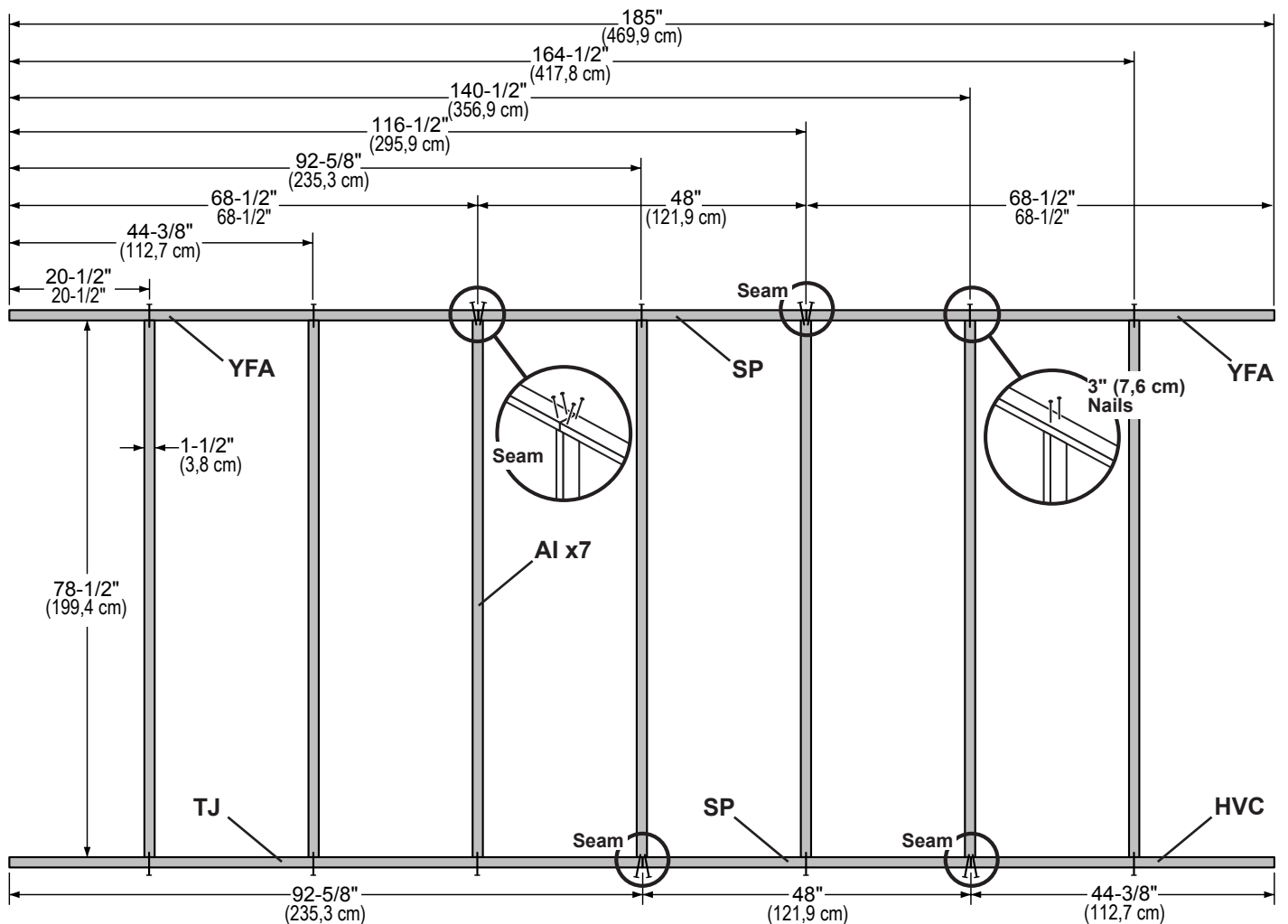
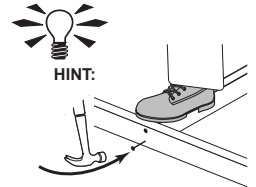

16' WALL 09

PARTS REQUIRED:

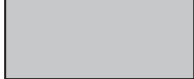
- x2  23-7/8" x 84"
(60,6 x 213,4 cm)
- x3  48 x 84" (121,9 x 213,4 cm)



2
Install 48" x 84" panel
1-1/2" from the top plate.

Use a 2x3 spacer
for consistent
measurement.

Secure panel with
2" nails spaced 6"
apart on edges and
12" inside panel.

**Note the panel
lip-edge/square
edge orientation.**

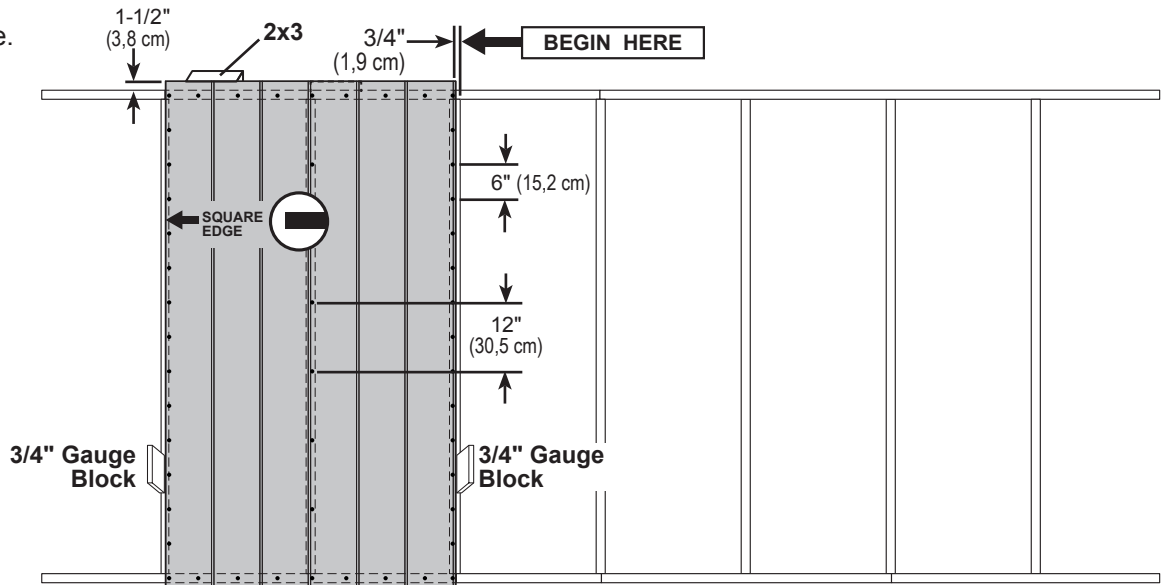

3
Install (2) 48" x 84"
panels and (2)
23-7/8" x 84"
panels flush to
installed panels.

Locate panels 1-1/2"
from the top plate.

Secure with 2" nails
spaced 6" apart on
edges and 12" apart
inside panel.

**Note the panel
lip-edge/square
edge orientation.**

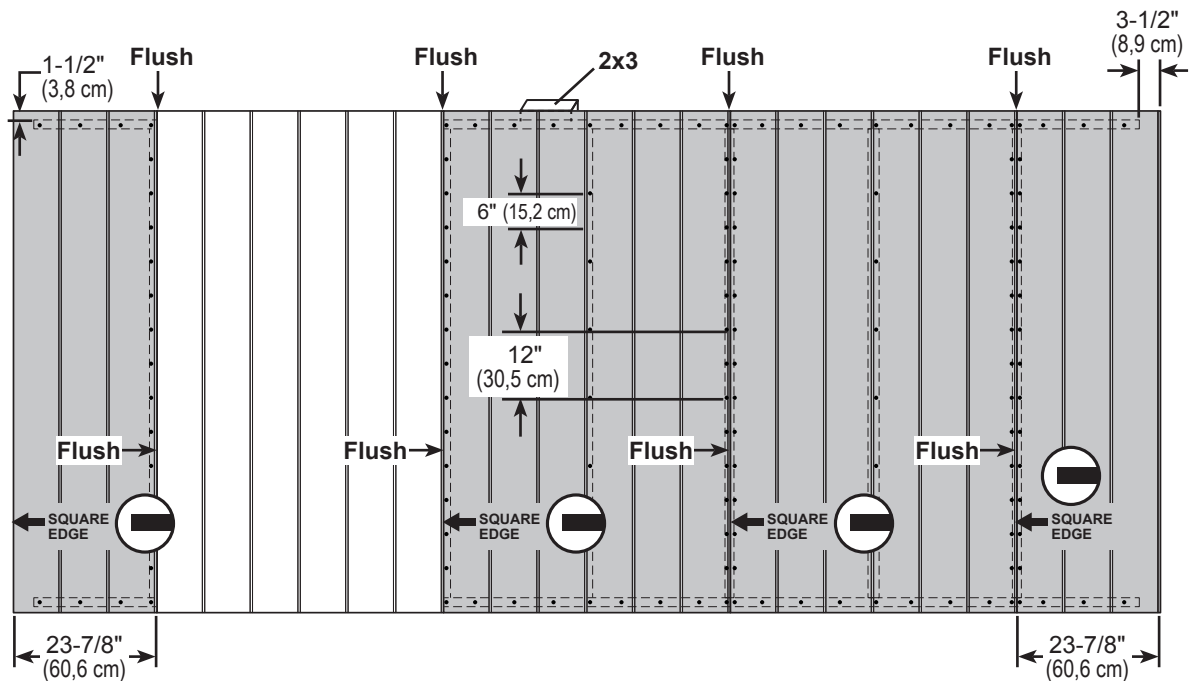

Your 16' WALL 09 is now assembled.

Carefully flip the wall over.

16' WALL 10

PARTS REQUIRED:

x1	HVC	2 x 4 x 44-3/8" (5,1 x 10,2 x 112,7 cm)
x2	SP	2 x 4 x 48" (5,1 x 10,2 x 121,9 cm)
x2	UM	2 x 4 x 68" (5,1 x 10,2 x 172,7 cm)
x2	YFA	2 x 4 x 68-1/2" (5,1 x 10,2 x 174 cm)
x6	AI	2 x 4 x 78-1/2" (5,1 x 10,2 x 199,4 cm)
x1	TJ	2 x 4 x 92-5/8" (5,1 x 10,2 x 235,3 cm)
x1	Pre Assembled Header	
x5	AL	2 x 4 x 7" (5,1 x 10,2 x 17,8 cm)

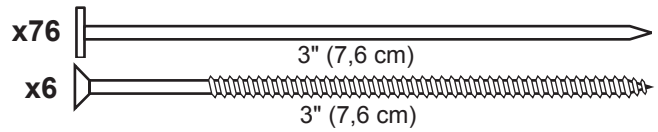

✓ BEGIN

- 1** Orient parts on edge on floor as shown. Measure and mark from end of boards.
Orient **Pre Assembled Header** on flat side (**Fig. A**).
Secure with (2) 3" nails at each connection and (4) 3" nails at seams.
- 2** Fasten (3) middle parts **AL** to **Pre Assembled Header** with (2) 3" screws (**Fig. B**).
Fasten (2) end **AL** to studs **AI** with (4) 3" nails at each side.
Secure parts **AL** to top plates with (2) 3" nails at each connection and (4) 3" nails at seam.

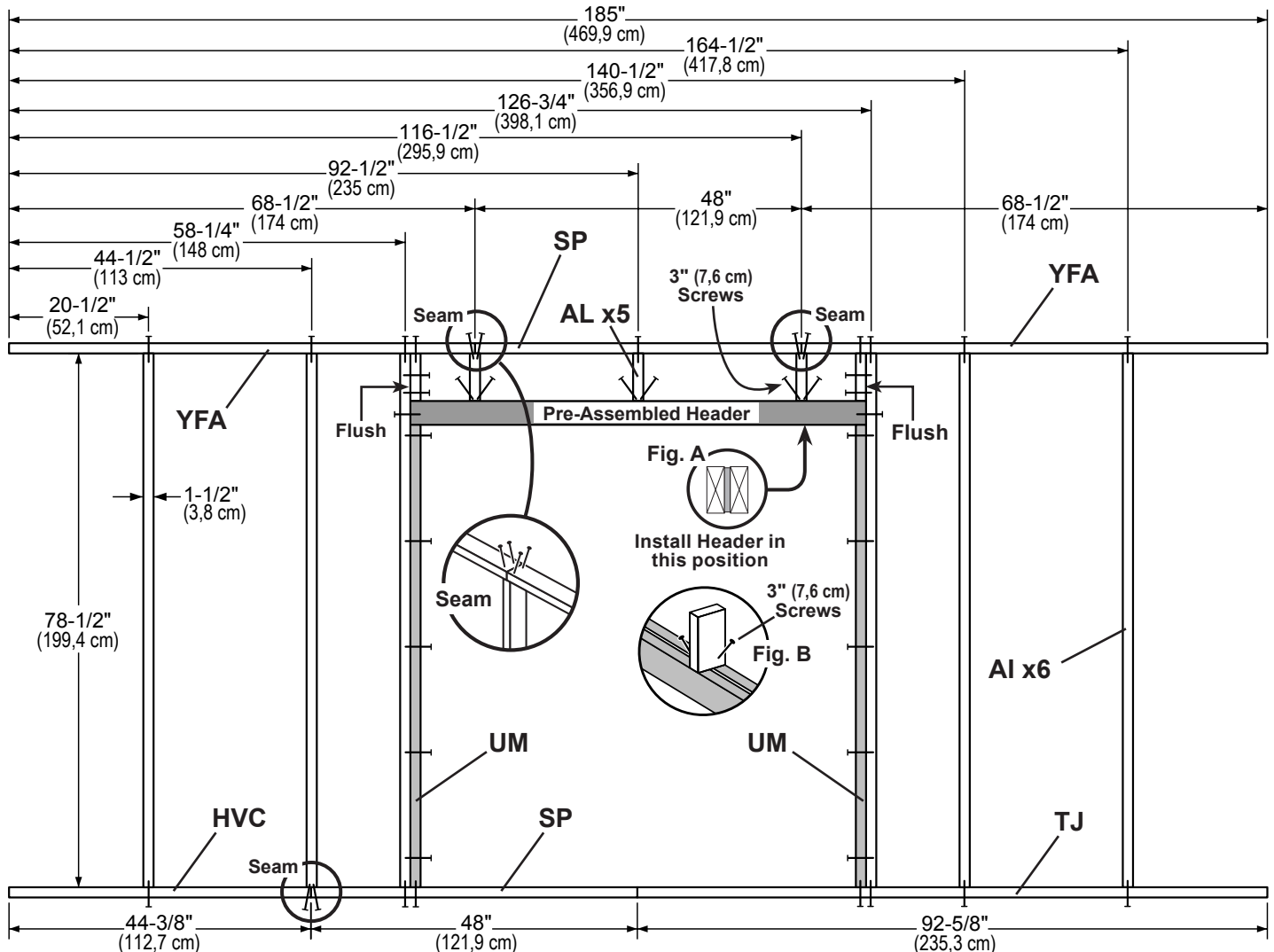

16' WALL 10

PARTS REQUIRED:

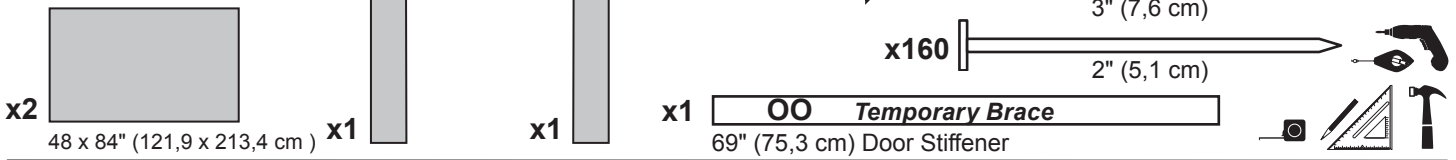

3

Install the left panel 1-1/2" from the top plate. Use a 2x3 spacer for consistent measurement.

Secure panel with 2" nails spaced 6" apart on edges.

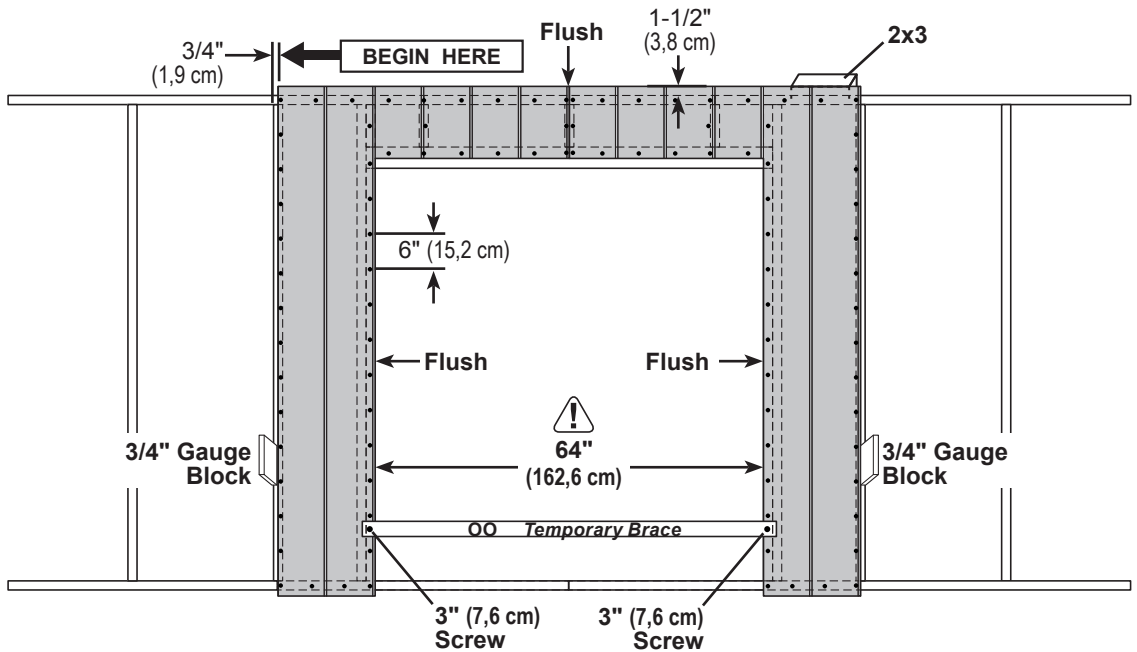

4

Install the right panel flush to installed panel, as shown.

Ensure 64" (162,8 cm) door measurement.

Use part OO as a temporary brace. Secure with with (2) 3" screws.

Secure panel with 2" nails spaced 6" apart on edges.

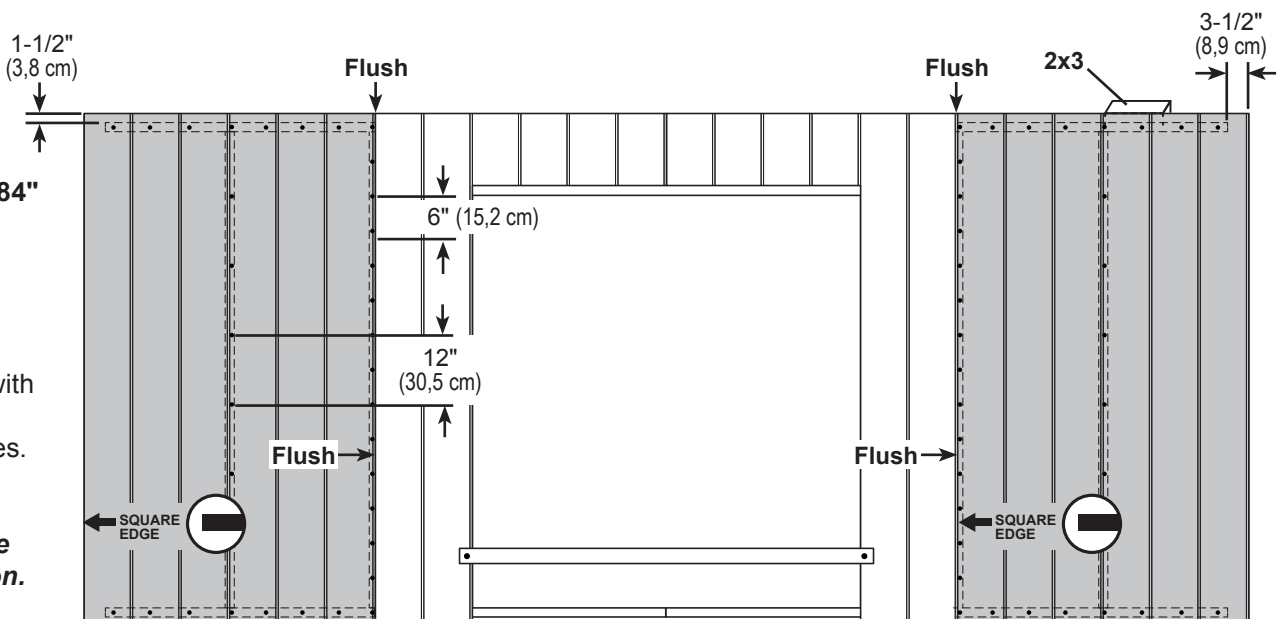

5

Install (2) 48" x 84" panels flush to installed panels and 1-1/2" from the top plate.

Secure panels with 2" nails spaced 6" apart on edges.

Note the panel lip-edge/square edge orientation.

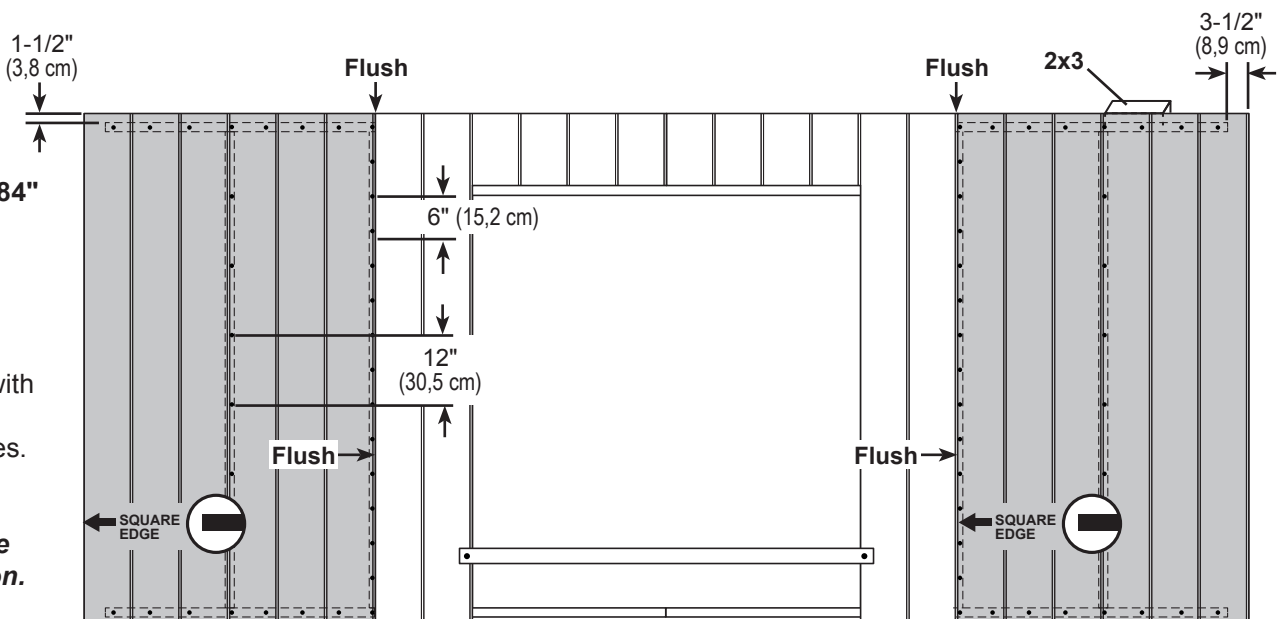

Your 16' WALL 10 is now assembled. Carefully flip the wall over.

16' WALL 11

PARTS REQUIRED:

x1	HVC	2 x 4 x 44-3/8" (5,1 x 10,2 x 112,7 cm)
x2	SP	2 x 4 x 48" (5,1 x 10,2 x 121,9 cm)
x2	UM	2 x 4 x 68" (5,1 x 10,2 x 172,7 cm)
x2	YFA	2 x 4 x 68-1/2" (5,1 x 10,2 x 174 cm)
x6	AI	2 x 4 x 78-1/2" (5,1 x 10,2 x 199,4 cm)
x1	TJ	2 x 4 x 92-5/8" (5,1 x 10,2 x 235,3 cm)
Pre Assembled Header		
x1	AL	2 x 4 x 7" (5,1 x 10,2 x 17,8 cm)

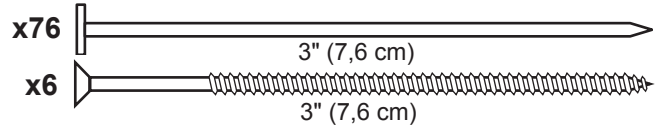

✓ BEGIN

- 1** Orient parts on edge on floor as shown. Measure and mark from end of boards.
Orient **Pre Assembled Header** on flat side (**Fig. A**).
Secure with (2) 3" nails at each connection and (4) 3" nails at seams.
- 2** Fasten (3) middle parts **AL** to **Pre Assembled Header** with (2) 3" screws (**Fig. B**).
Fasten (2) end **AL** to studs **AI** with (4) 3" nails at each side.
Secure parts **AL** to top plates with (2) 3" nails at each connection and (4) 3" nails at seam.

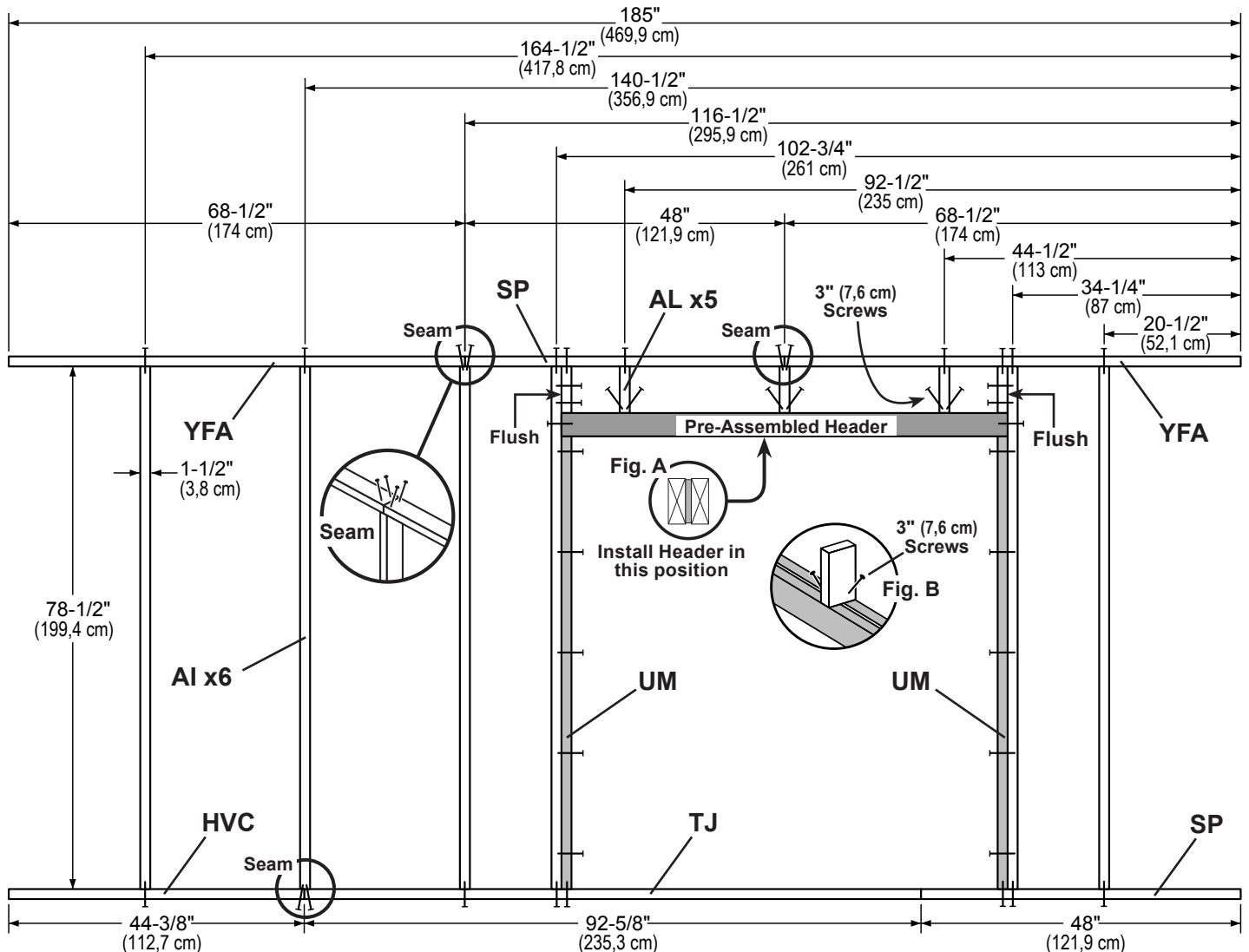

16' WALL 11

PARTS REQUIRED:

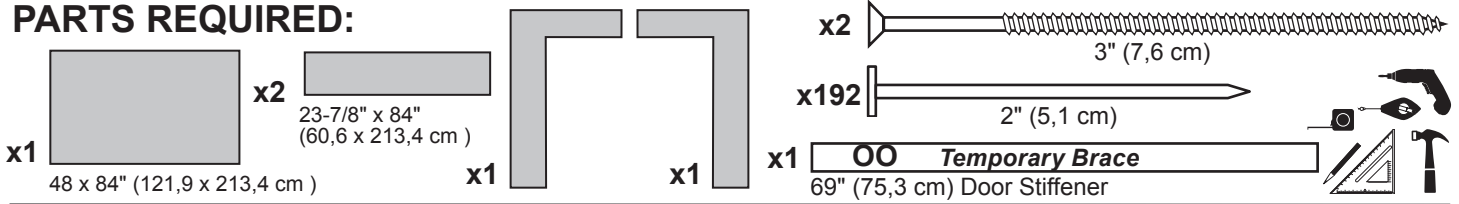

3

Install the left panel 1-1/2" from the top plate. Use a 2x3 spacer for consistent measurement.

Secure panel with 2" nails spaced 6" apart on edges.

4

Install the right panel flush to installed panel, as shown.

Ensure 64" (162,8 cm) door measurement.

Use part OO as a temporary brace. Secure with with (2) 3" screws.

Secure panel with 2" nails spaced 6" apart on edges.

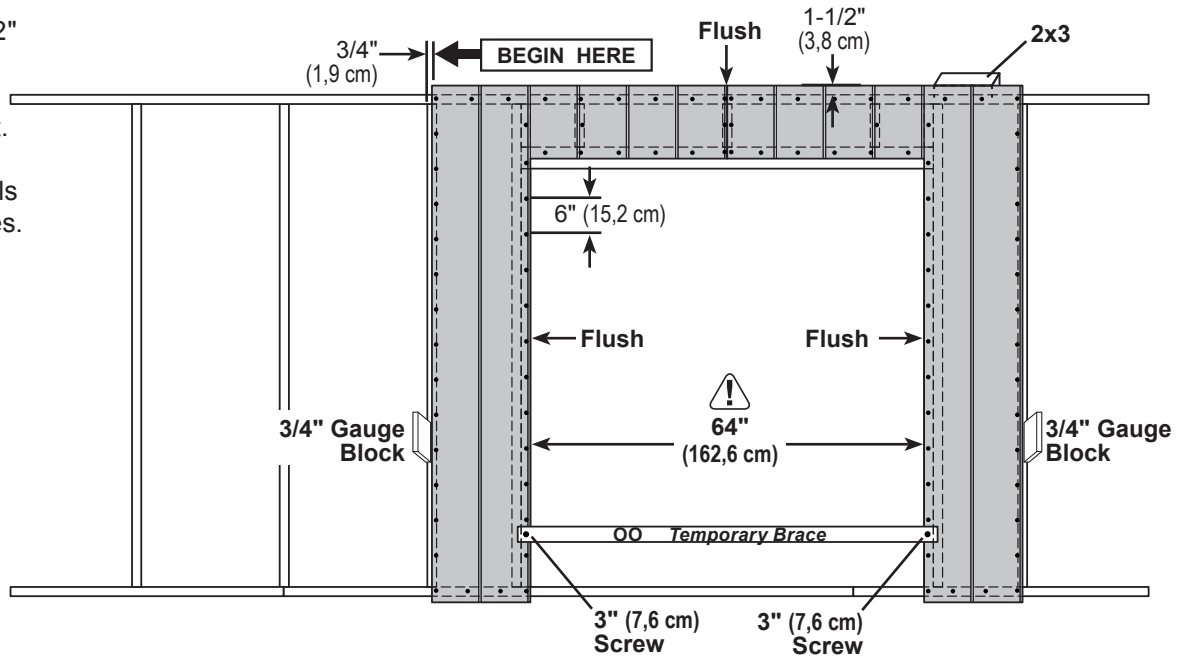

5

Install (2) 23-7/8" x 84" and (1) 48" x 84" panels flush to installed panels and 1-1/2" from the top plate.

Secure panels with 2" nails spaced 6" apart on edges.

Note the panel lip-edge/square edge orientation.

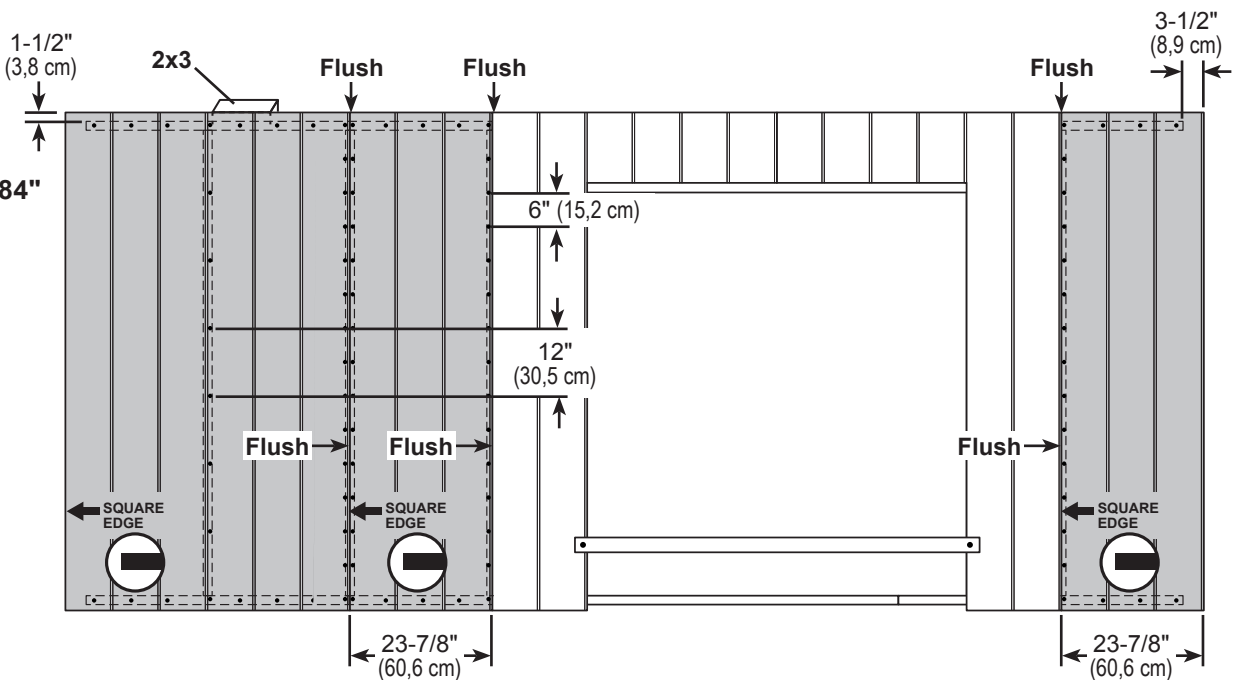

Your 16' WALL 11 is now assembled. Carefully flip the wall over.

16' WALL 12

PARTS REQUIRED:

x1	HVC	2 x 4 x 44-3/8" (5,1 x 10,2 x 112,7 cm)
x2	SP	2 x 4 x 48" (5,1 x 10,2 x 121,9 cm)
x2	UM	2 x 4 x 68" (5,1 x 10,2 x 172,7 cm)
x2	YFA	2 x 4 x 68-1/2" (5,1 x 10,2 x 174 cm)
x6	AI	2 x 4 x 78-1/2" (5,1 x 10,2 x 199,4 cm)
x1	TJ	2 x 4 x 92-5/8" (5,1 x 10,2 x 235,3 cm)
Pre Assembled Header		
x1	AL	2 x 4 x 7" (5,1 x 10,2 x 17,8 cm)

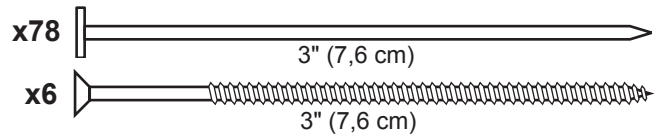

✓ BEGIN

- 1** Orient parts on edge on floor as shown. Measure and mark from end of boards.
 Orient **Pre Assembled Header** on flat side (**Fig. A**).
 Secure with (2) 3" nails at each connection and (4) 3" nails at seams.
- 2** Fasten (3) middle parts **AL** to **Pre Assembled Header** with (2) 3" screws (**Fig. B**).
 Fasten (2) end **AL** to studs **AI** with (4) 3" nails at each side.
 Secure parts **AL** to top plates with (2) 3" nails at each connection and (4) 3" nails at seam.

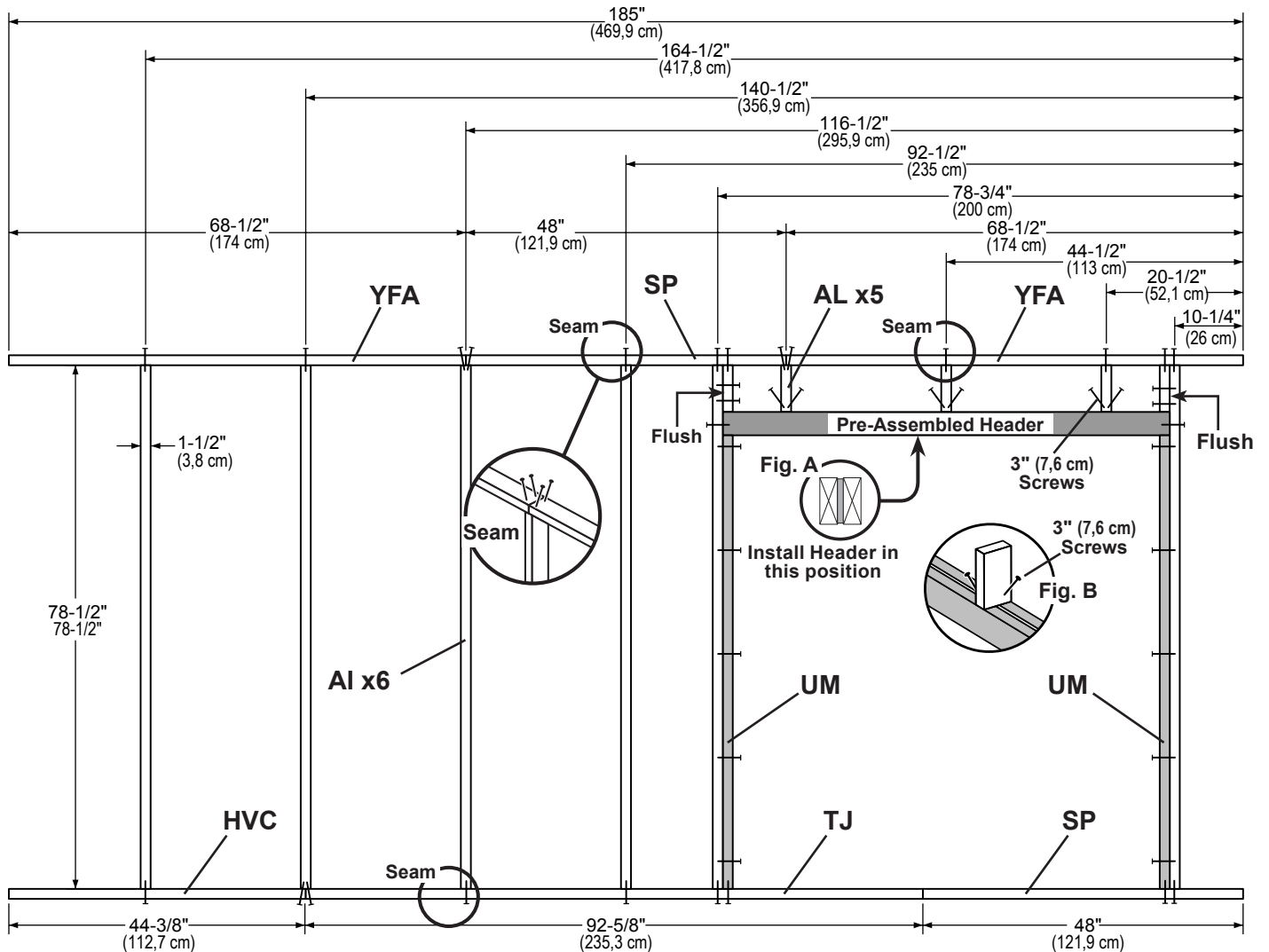

16' WALL 12

PARTS REQUIRED:

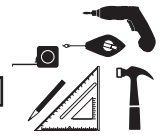
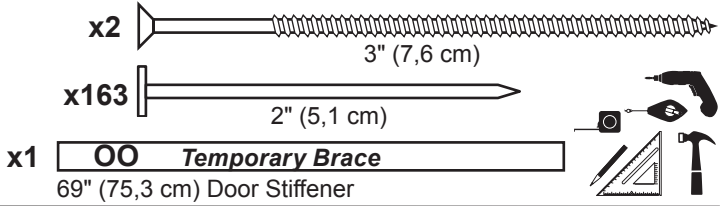
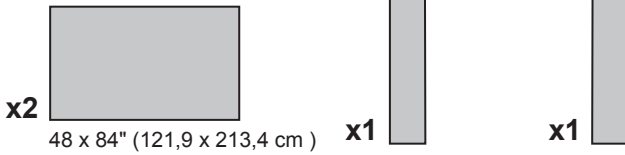

3

Install the left panel 1-1/2" from the top plate. Use a 2x3 spacer for consistent measurement.

Secure panel with 2" nails spaced 6" apart on edges.

4

Install the right panel flush to installed panel, as shown. Ensure 64" (162,8 cm) door measurement. Use part OO as a temporary brace. Secure with with (2) 3" screws.

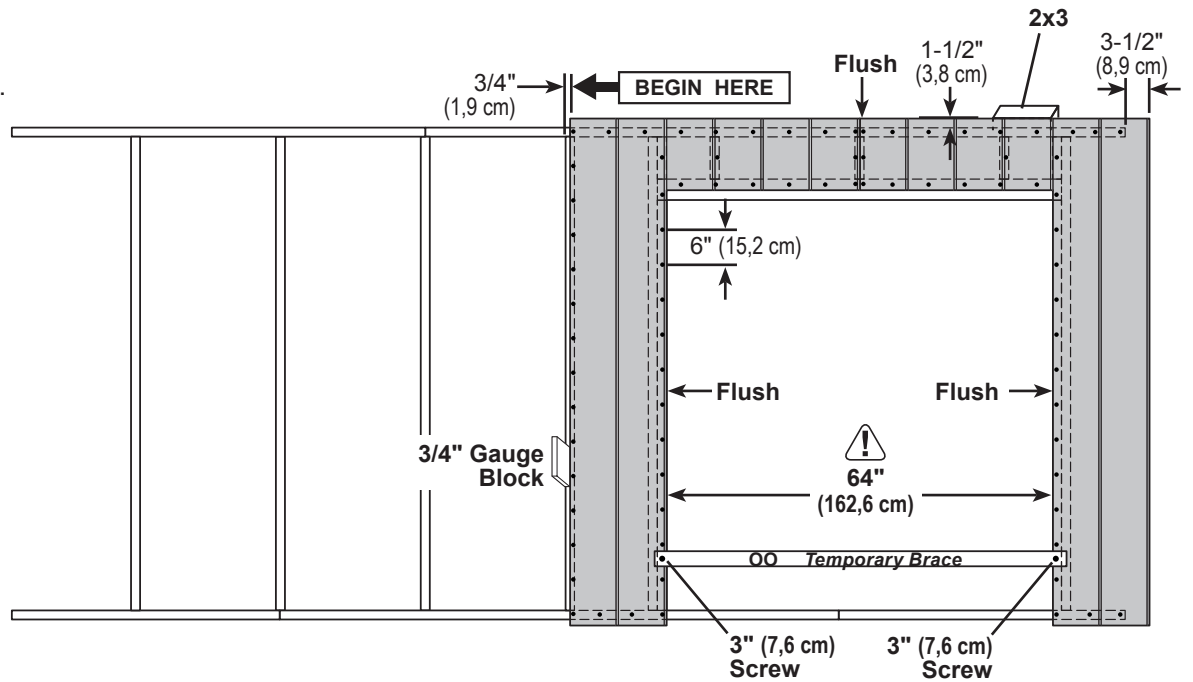

Secure panel with 2" nails spaced 6" apart on edges.

5

Install (2) 48" x 84" panels flush to installed panels and 1-1/2" from the top plate.

Secure panels with 2" nails spaced 6" apart on edges.

Note the panel lip-edge/square edge orientation.

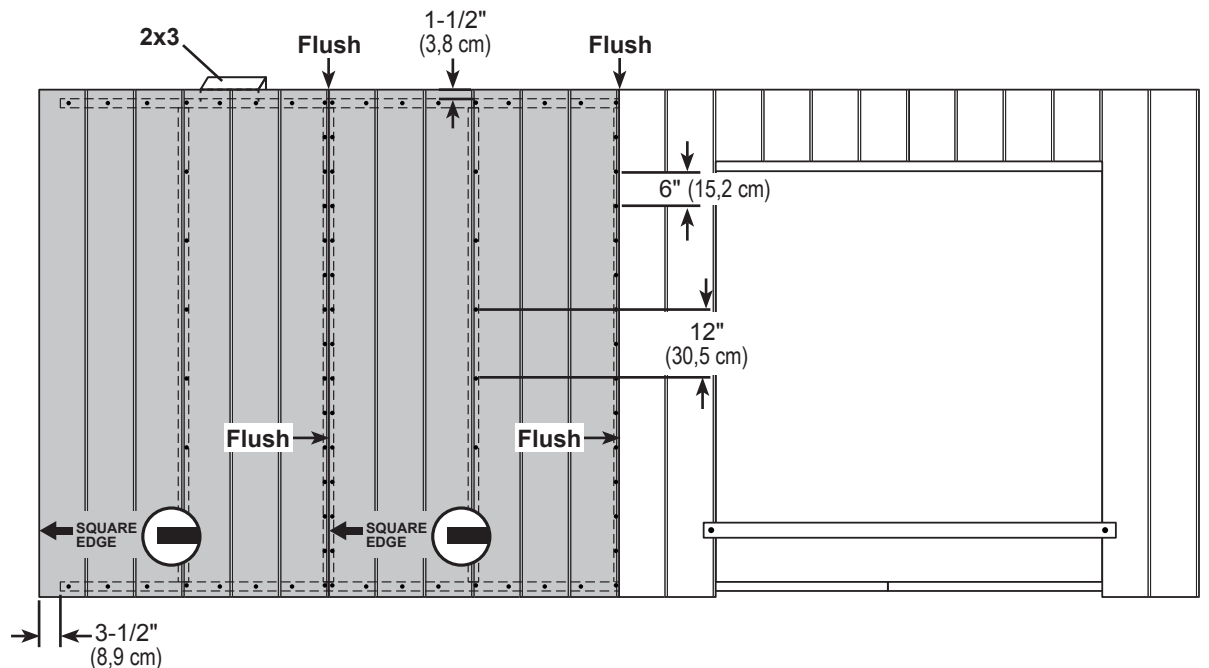

Your 16' WALL 12 is now assembled. Carefully flip the wall over.

STANDING YOUR WALLS

The following steps show how to stand and secure your walls for a 10' x 12' shed.

These instructions are by default with the door on the 10' gable wall.

For 10' x 16' steps, start on page 48.

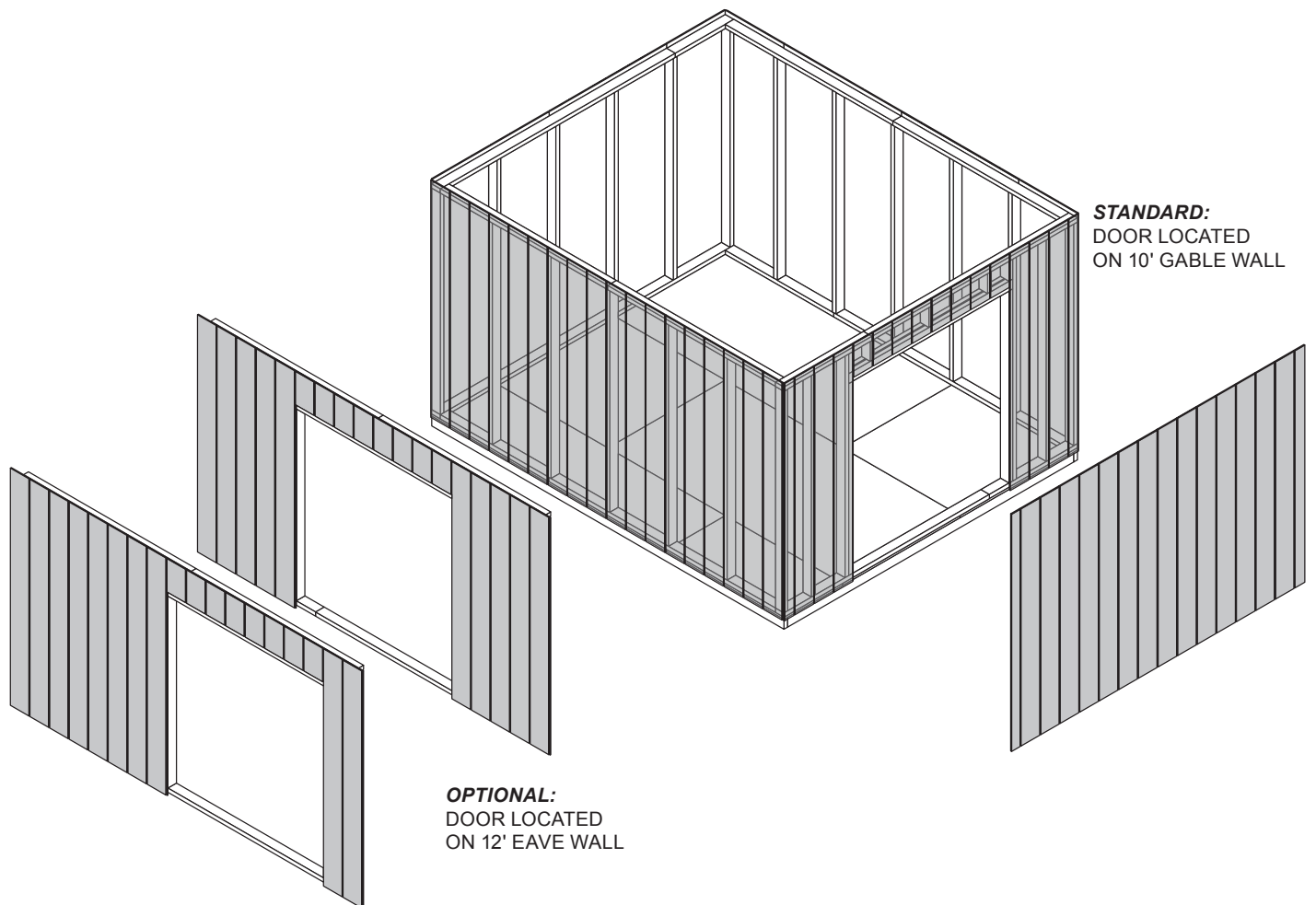

10' WALL INSTALLATION

PARTS REQUIRED:

x1 **OO**
69" (175,3 cm) Door Stiffener



x10 3" (7,6 cm)
x2 3" (7,6 cm)
x23 2" (5,1 cm)

✓ BEGIN

Center 10' wall on the 120" (304,8 cm) floor dimension.

1-1/2" (3,8 cm) overlap is to the top.

Use **OO** as a temporary brace.

Secure with (2) 3" screws.

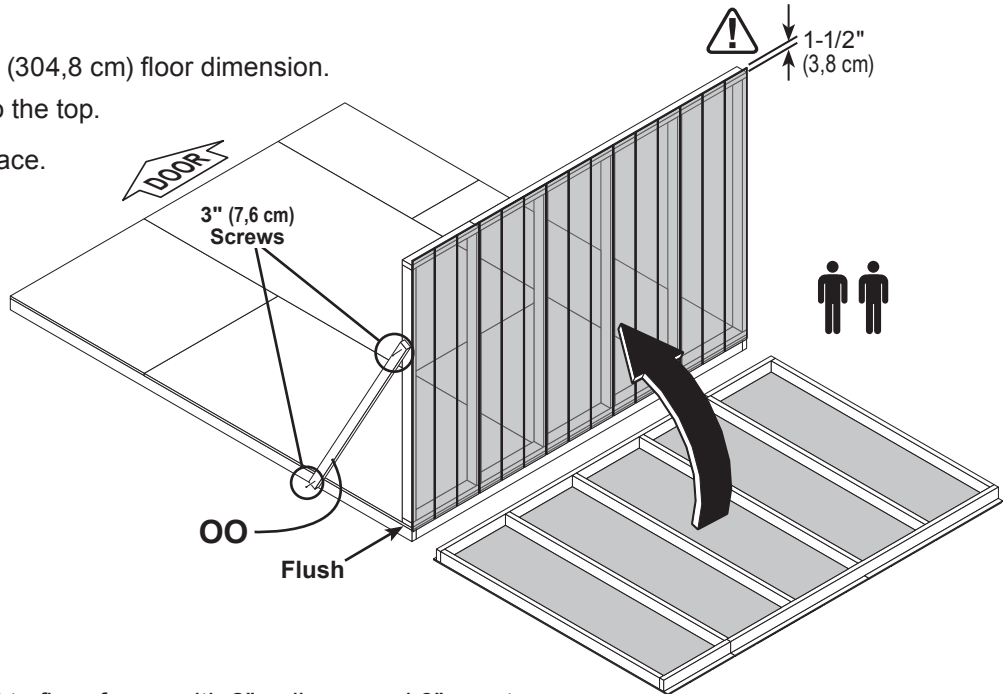

- Secure lower edge of panel to floor frame with 2" nails spaced 6" apart. Angle nails into floor frame (**Fig. A**).

Secure wall bottom plates to floor with 3" nails (**Fig. A**).

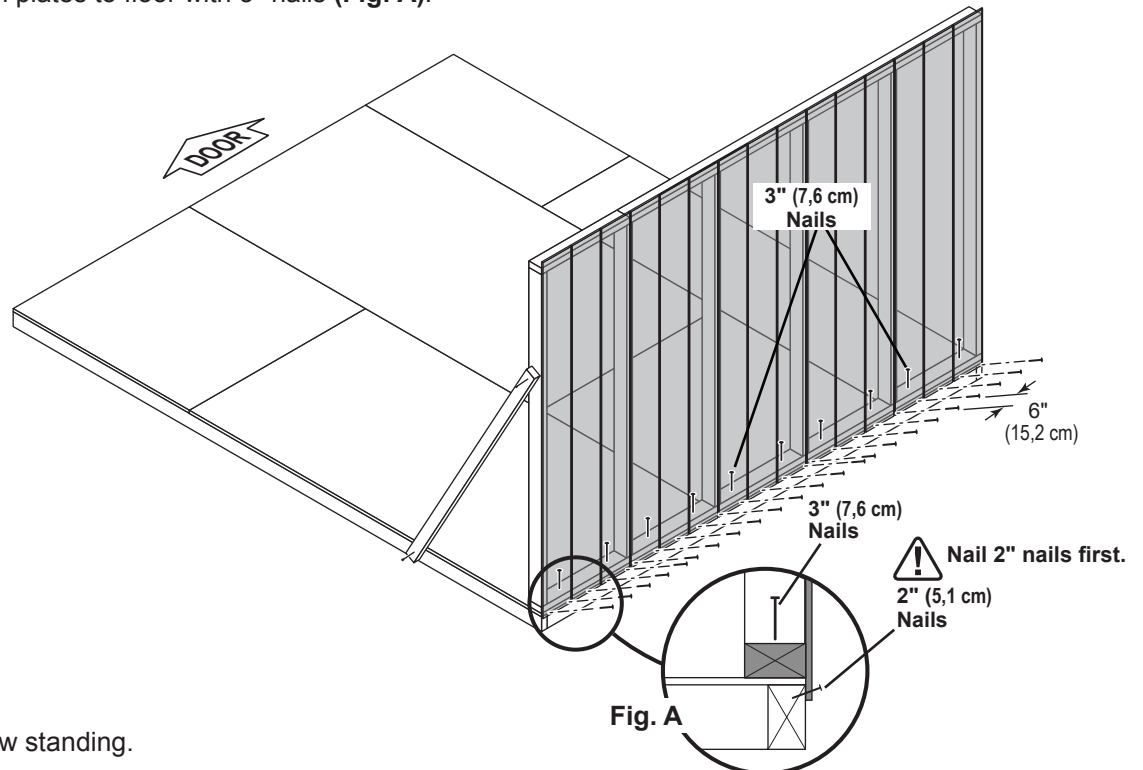

Your 10' wall is now standing.

12' WALL INSTALLATION

PARTS REQUIRED

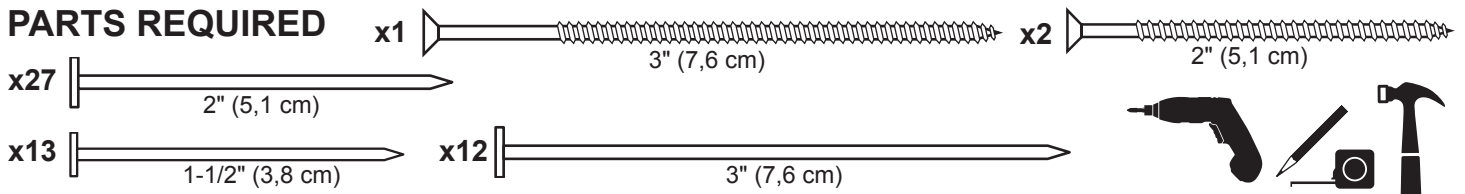

✓ BEGIN

- 1 Place 12' wall centered on floor.
1-1/2" (3,8 cm) overlap is to the top.

Secure wall with (1) 2" screw into 10' wall bottom plate (Fig. A) and top plate (Fig. B).

Secure wall to bottom plate first.
ENSURE PANEL CORNERS ARE FLUSH.

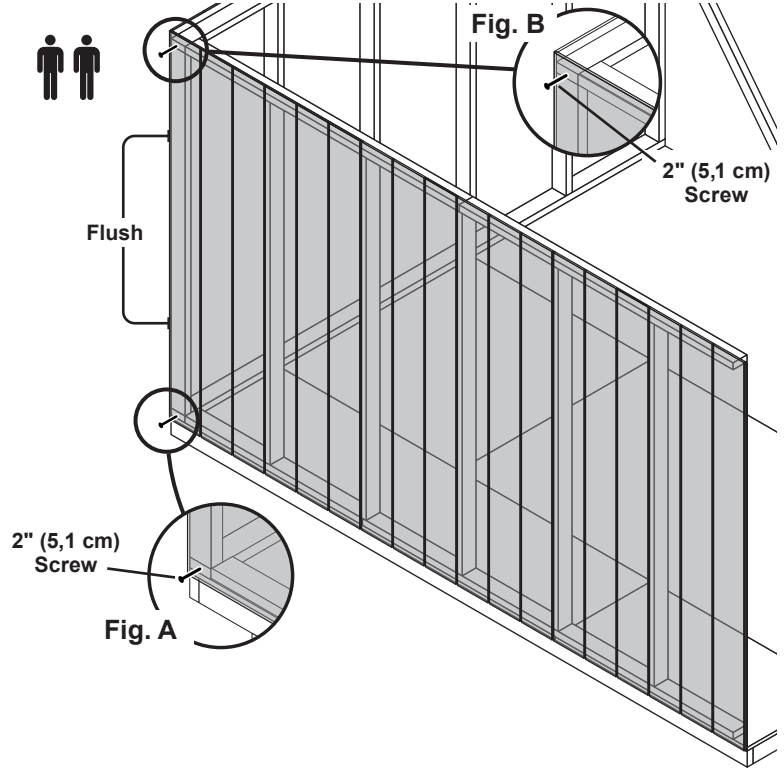
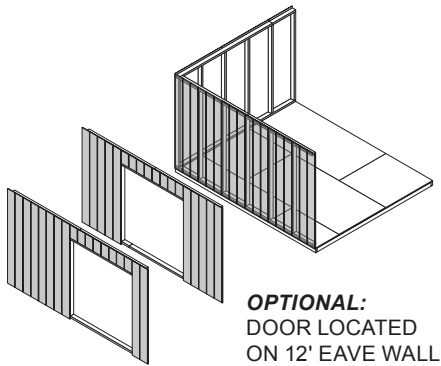

- 2 Nail lower edge of panels to floor with 2" nails spaced 6" apart.
Angle nails into floor frame (Fig. C).

Nail panel to 10' wall stud with 1-1/2" nails spaced 6" apart.

- 3 Secure wall top plate with (1) 3" screw angled at the corner at an angle as shown (Fig. D).

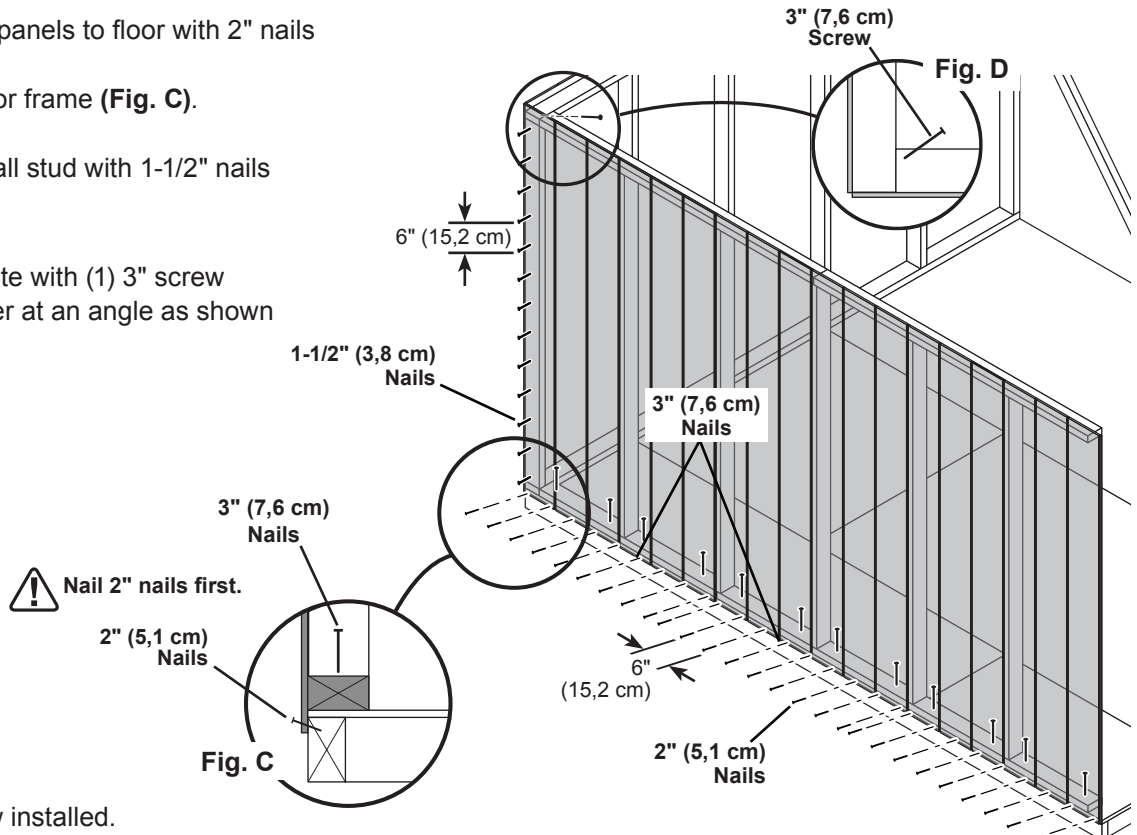

Your 12' wall is now installed.

12' WALL INSTALLATION

PARTS REQUIRED:

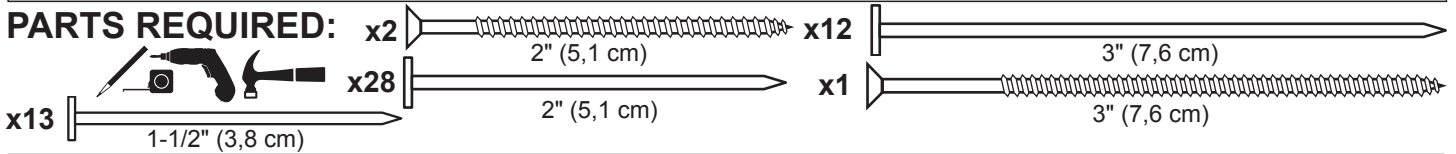

✓ BEGIN

- 1** Remove temporary brace **OO** from installed 10' wall.
 Place 12' wall centered on floor.
 1-1/2" (3,8 cm) overlap is to the top.

- 2** Secure wall with (1) 2" screw through gable wall panel into 10' wall bottom and top plates (**Fig. B, Fig. A**).
Secure wall to bottom plate first.

⚠ ENSURE PANEL CORNERS ARE FLUSH.

- 3** Nail lower edge of wall panels to floor frame with 2" nails spaced 6" apart.
 Angle nails into floor frame (**Fig. C**).

Secure wall bottom plates to floor with 3" nails (**Fig. C**).

- 4** Nail 12' wall panel to 10' wall stud with 1-1/2" nails spaced 6" apart.

- 5** Secure gable wall top plate with (1) 3" screw at the corner at an angle as shown (**Fig. D**).

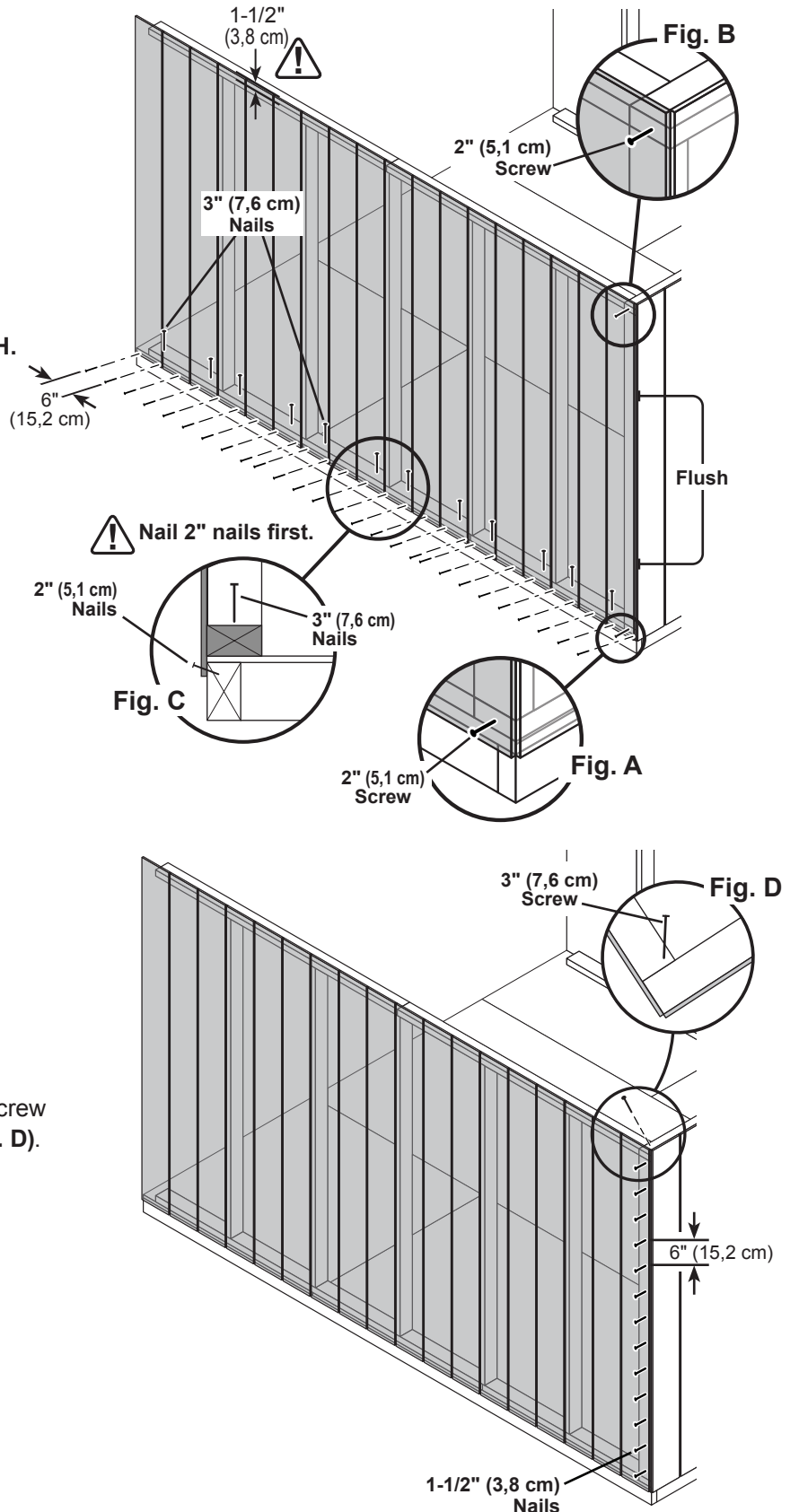

Your 2nd 12' wall is now installed.

10' WALL INSTALLATION

PARTS REQUIRED

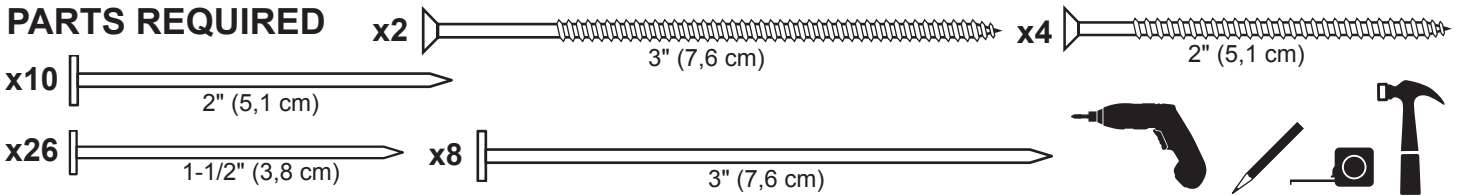

✓ BEGIN

1 Place 10' wall on floor centered between 12' walls.

Secure wall with 2" screws into top and bottom plates (Fig. A, Fig. B).

Secure wall to bottom plate first.

⚠ ENSURE PANEL CORNERS ARE FLUSH. ⚠

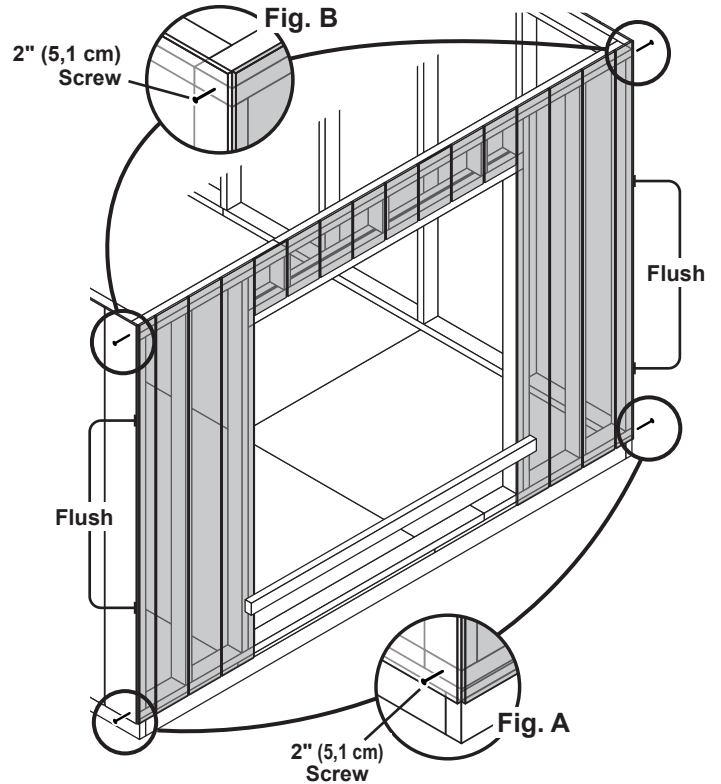
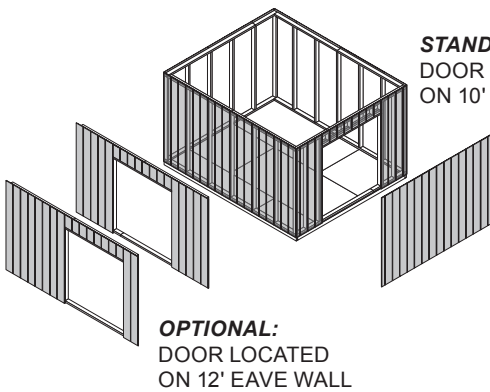

2 Nail lower edge of panels to floor with 2" nails spaced 6" apart. Angle nails into floor frame (Fig. C).

Nail panels to 10' wall studs with 1-1/2" nails spaced 6" apart.

3 Secure wall top plates with 3" screws at each corner at an angle (Fig. D).

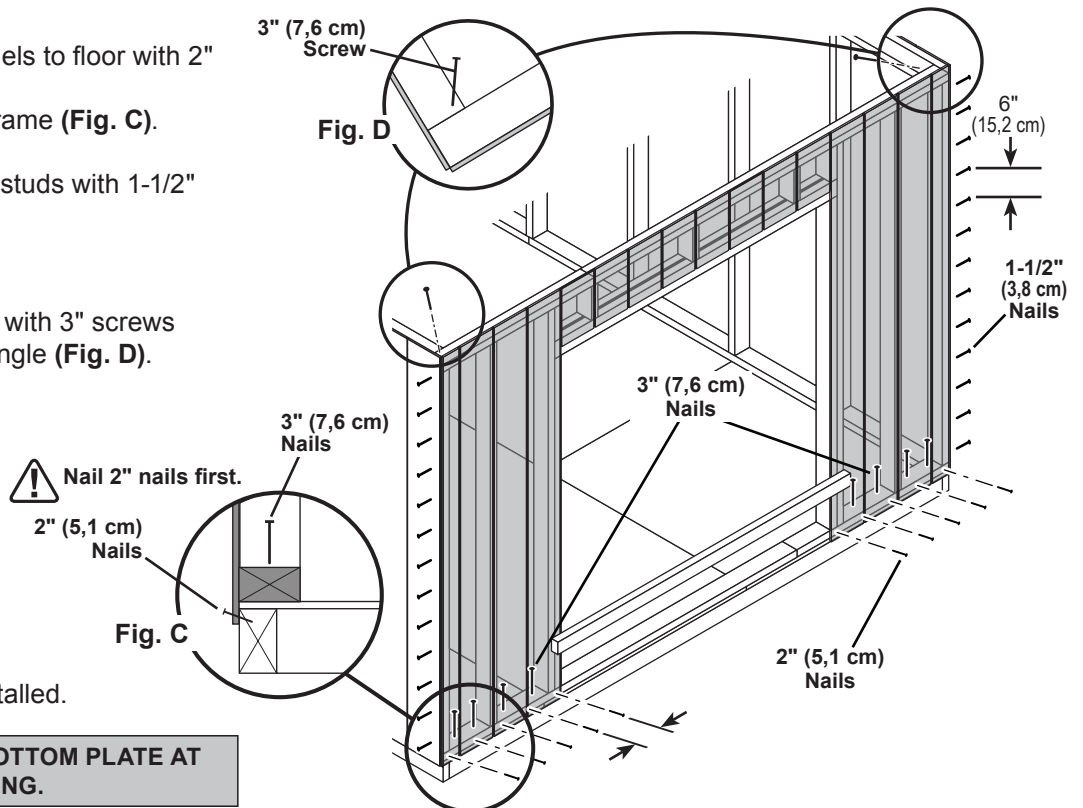

FINISH
Your walls are now installed.

CUT OUT AND REMOVE BOTTOM PLATE AT DOOR OPENING.

10' x 12' WALL DOUBLERS INSTALLATION

PARTS REQUIRED:

- x2 **SP**
2 x 4 x 48" (5,1 x 10,2 x 121,9 cm)
- x2 **JBD**
2 x 4 x 20-3/8" (5,1 x 10,2 x 51,8 cm)
- x2 **TJ**
2 x 4 x 92-5/8" (5,1 x 10,2 x 235 cm)
- x2 **TP**
2 x 4 x 96" (5,1 x 10,2 x 243,8 cm)

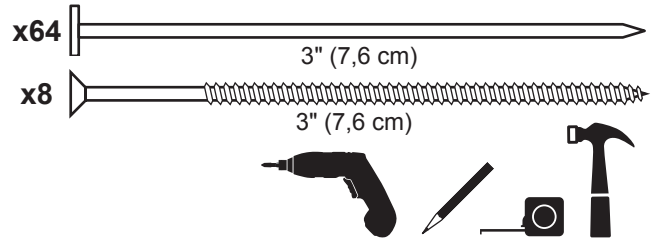

✓ BEGIN

- 1 Orient parts on top of wall frames. Secure from top with (2) 3" nails spaced every 24" (Fig. A).
- 2 Secure from bottom with (2) 3" screws at each corner (Fig. B).
- 3 Secure from bottom with (2) 3" screws at each corner (Fig. B).

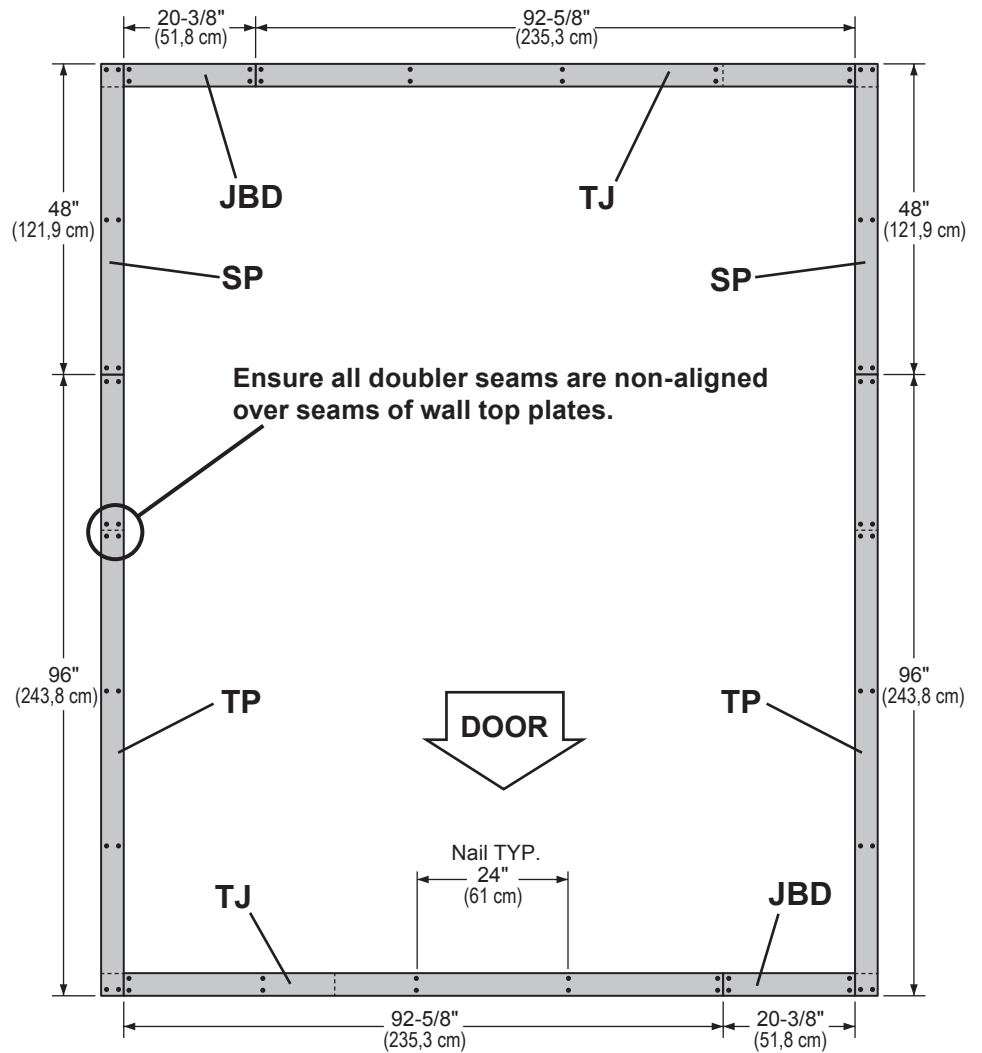
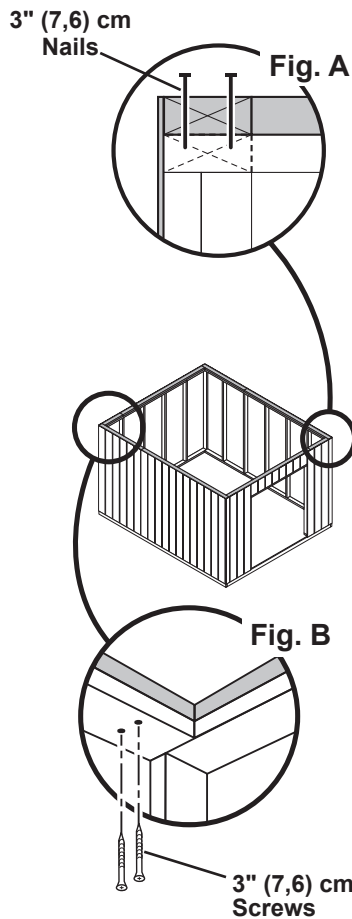

Your wall doublers are now installed.

CONTINUE TO PAGE 54 TO RESUME CONSTRUCTION OF 10' X 12' SHED.

16' WALL INSTALLATION

PARTS REQUIRED:

x1 **OO**
69" (175,3 cm) Door Stiffener



x10 3" (7,6 cm)
 x2 3" (7,6 cm)
 x23 2" (5,1 cm)

✓ BEGIN

1

Center 10' wall on the 120" (304,8 cm) floor dimension.
 1-1/2" (3,8 cm) overlap is to the top.

Use **OO** as a temporary brace.
 Secure with (2) 3" screws.

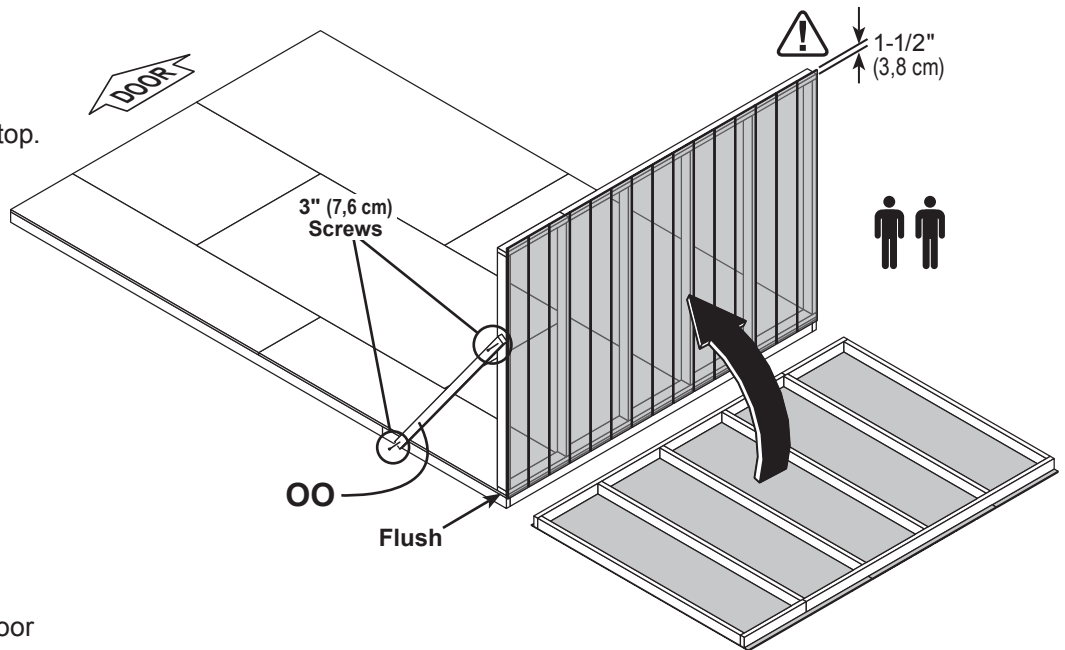

2

Secure lower edge of panel to floor frame with 2" nails spaced 6" apart.
 Angle nails into floor frame (**Fig. A**).

Secure wall bottom plates to floor with 3" nails (**Fig. A**).

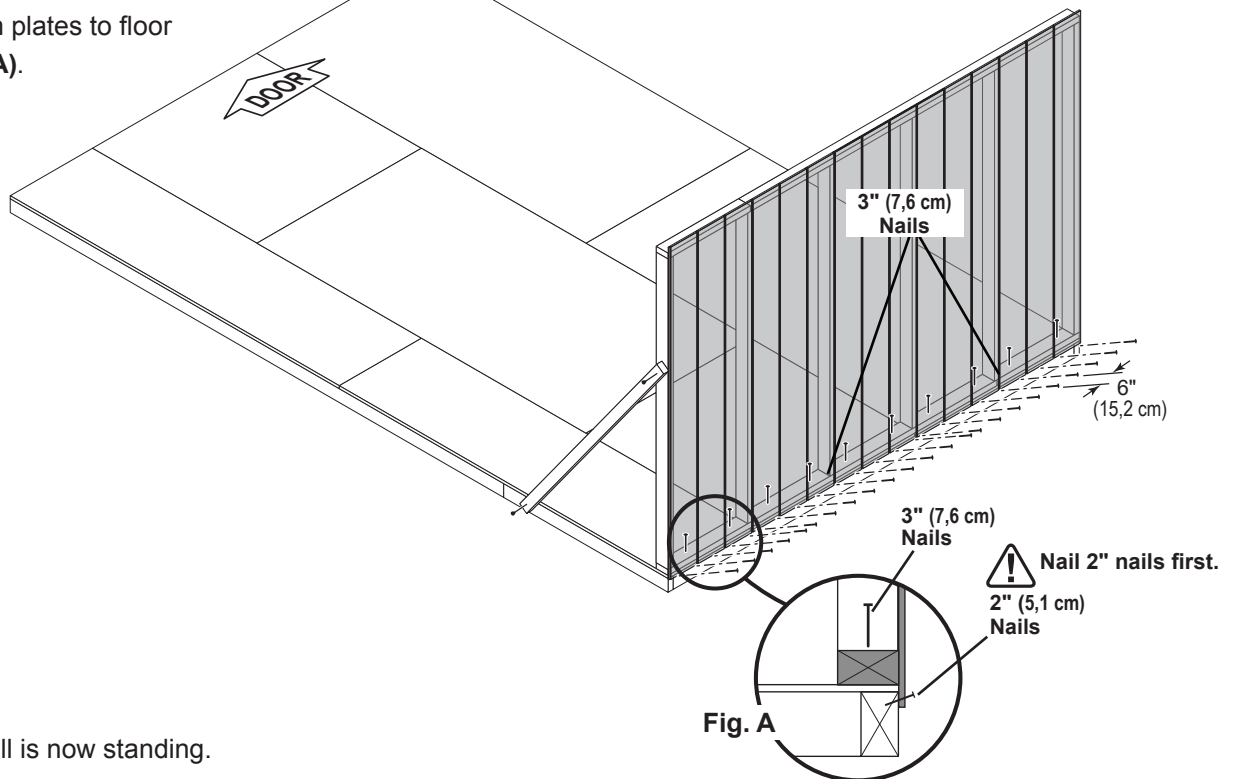

Your 10' wall is now standing.

16' WALL INSTALLATION

PARTS REQUIRED

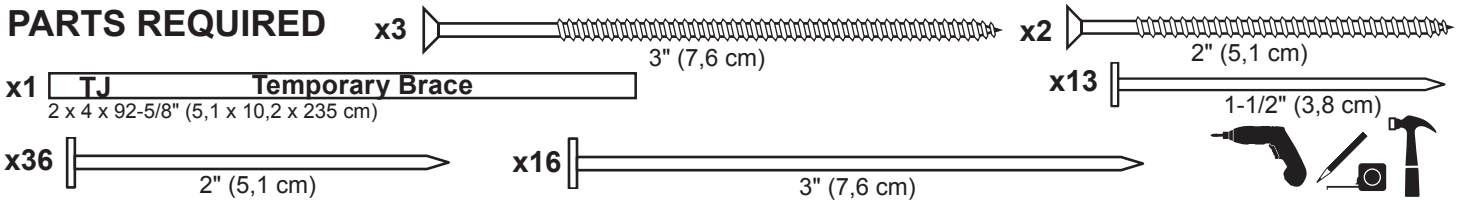

✓ BEGIN 1

Place 16' wall centered on floor.
The 1-1/2" (3,8 cm) overlap is to the top.
Use TJ as a temporary brace as shown.
Secure TJ with (2) 3" screws.

Secure wall with (1) 2" screw into 10' wall bottom plate (Fig. A) and top plate (Fig. B).

Secure wall to bottom plate first.

⚠ ENSURE PANEL CORNERS ARE FLUSH.

OPTIONAL:
DOOR LOCATED
ON 16' EAVE WALL

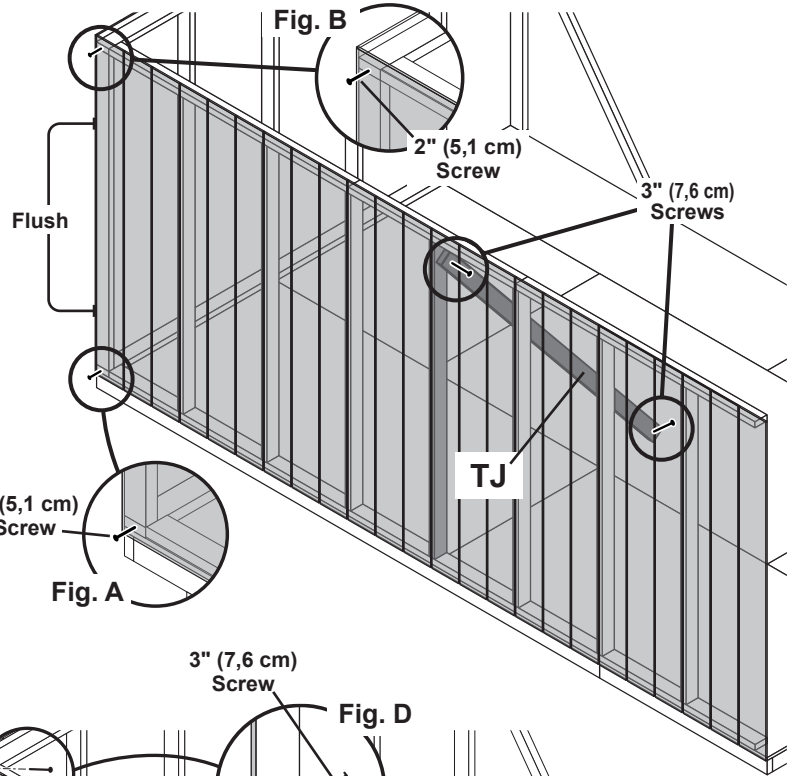
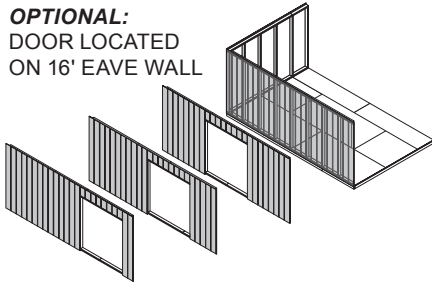

2

Nail lower edge of panels to floor with 2" nails spaced 6" apart.
Angle nails into floor frame (Fig. C).

Nail panel to 10' wall stud with 1-1/2" nails spaced 6" apart.

3

Secure wall top plate with (1) 3" screw at the corner at an angle as shown (Fig. D).

⚠ Nail 2" nails first.

2" (5,1 cm) Nails

3" (7,6 cm) Nails

Fig. C

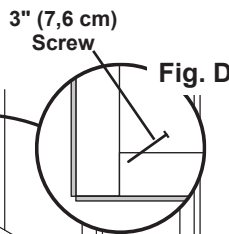

6" (15,2 cm)
1-1/2" (3,8 cm) Nails

3" (7,6 cm) Nails



6" (15,2 cm)

2" (5,1 cm) Nails

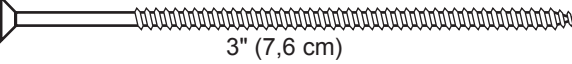
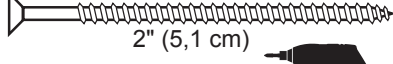

Your 16' wall is now installed.

16' WALL INSTALLATION

PARTS REQUIRED: x2  3" (7,6 cm) x2  2" (5,1 cm) 

x1  **TJ Temporary Brace**
2 x 4 x 92-5/8" (5,1 x 10,2 x 235 cm)

✓ **BEGIN**
1

Remove temporary brace **OO** from installed 10' wall.

Place 16' wall centered on floor.
1-1/2" (3,8 cm) overlap is to the top.

Use **TJ** as a temporary brace as shown.
Secure **TJ** with (2) 3" screws.

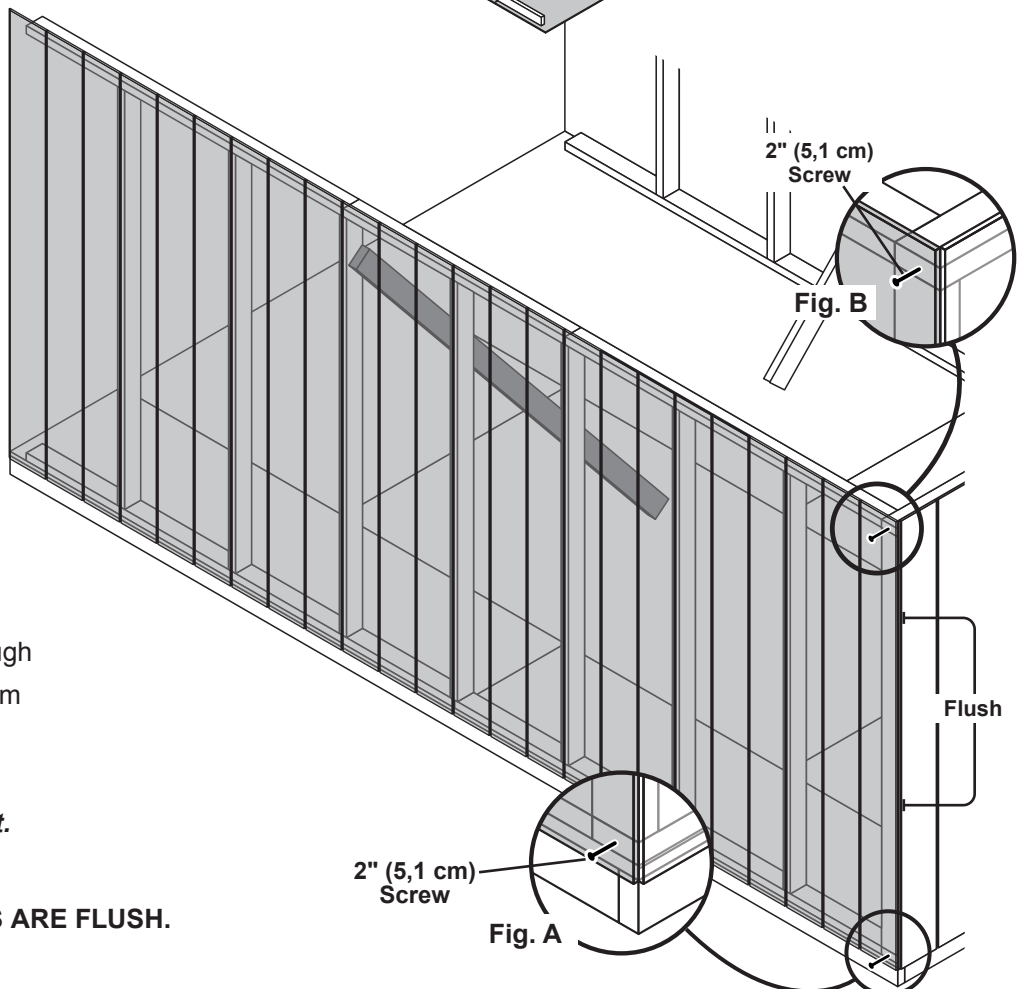
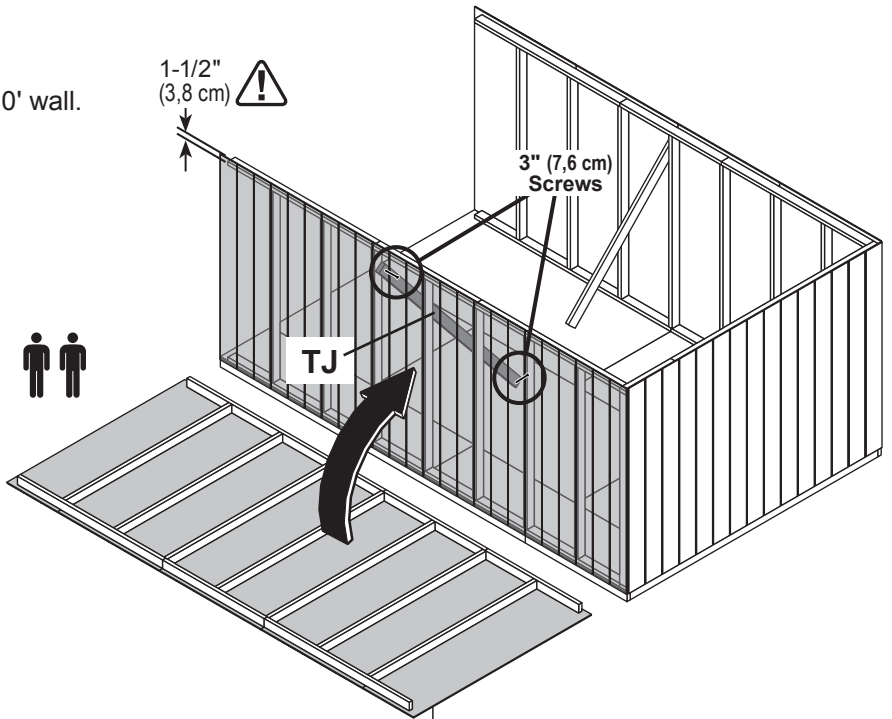

2
Secure wall with (1) 2" screw through gable wall panel into 10' wall bottom and top plates (**Fig. A**, **Fig. B**).

Secure wall to bottom plate first.

 **ENSURE PANEL CORNERS ARE FLUSH.**

16' WALL INSTALLATION

PARTS REQUIRED:

x37 2" (5,1 cm)

x13 1-1/2" (3,8 cm)

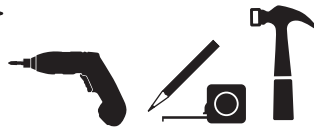

x16 3" (7,6 cm)

x1 3" (7,6 cm)

3

Nail lower edge of wall panels to floor frame with 2" nails spaced 6" apart. Angle nails into floor frame (**Fig. C**).

Secure wall bottom plates to floor with 3" nails (**Fig. C**).

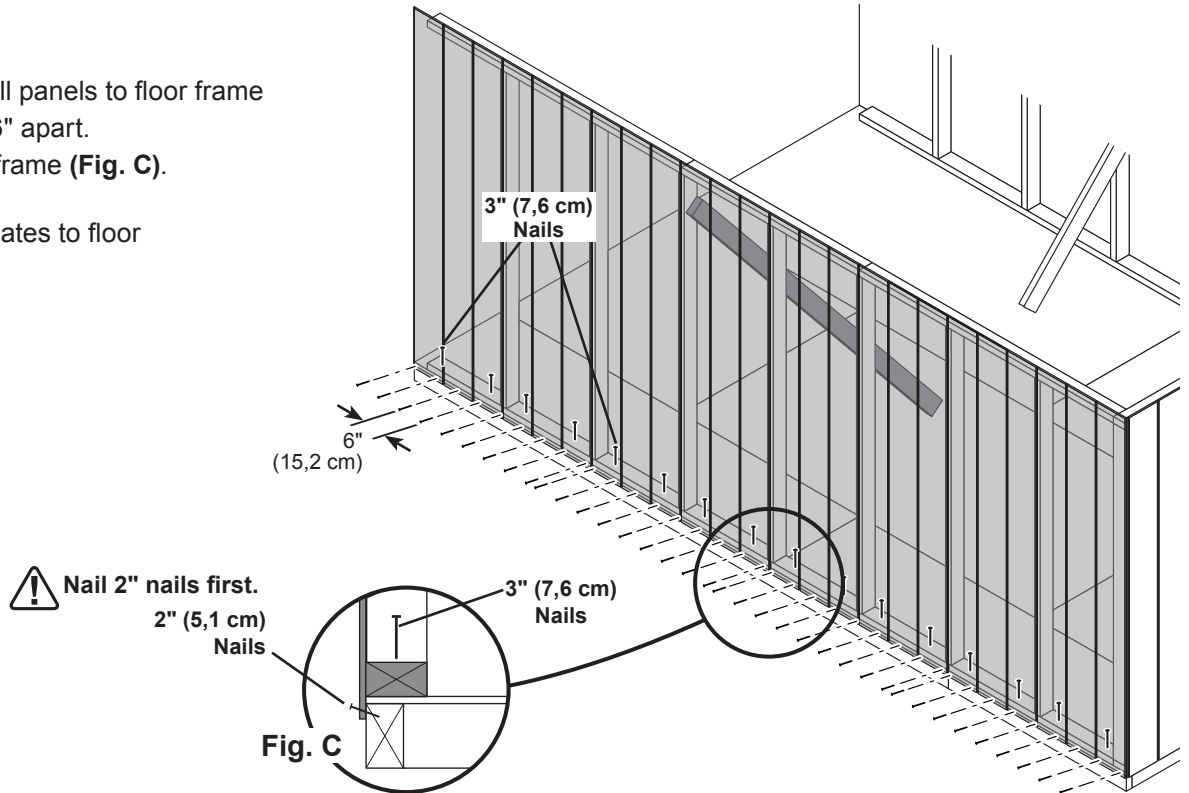

4

Nail 12' wall panel to 10' wall stud with 1-1/2" nails spaced 6" apart.

5

Secure gable wall top plate with (1) 3" screw at the corner at an angle as shown (**Fig. D**).

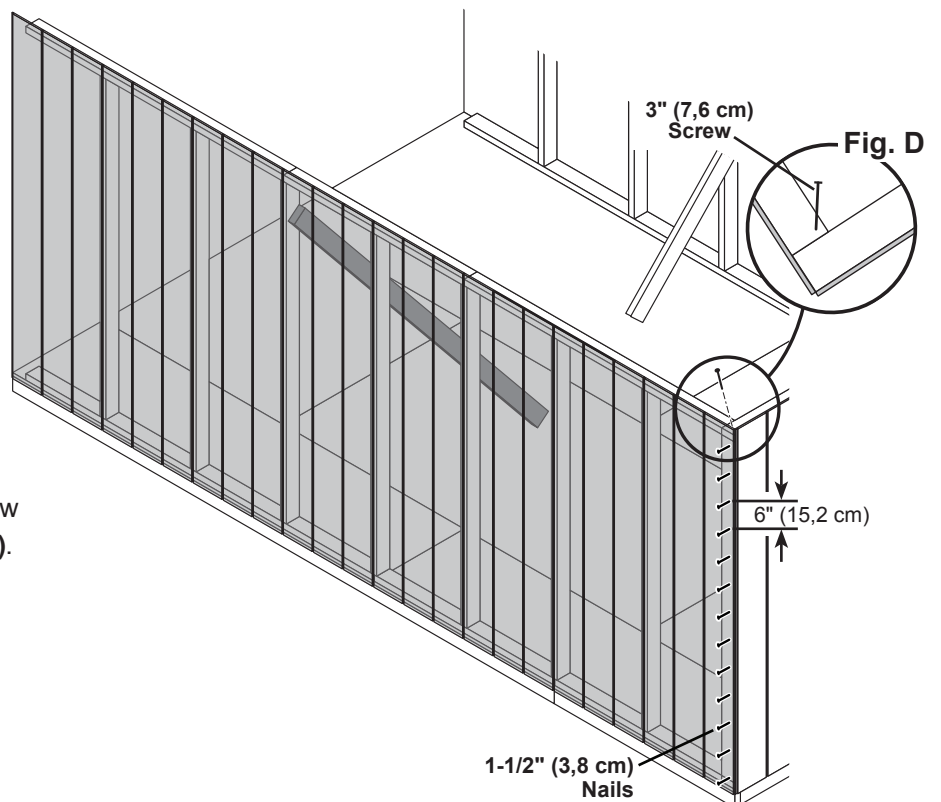

Your 2nd 16' wall is now installed.

10' WALL INSTALLATION

PARTS REQUIRED

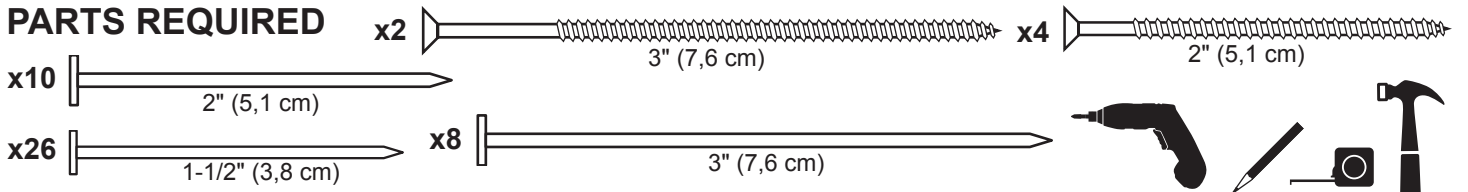

✓ BEGIN

1 Place 10' wall on floor centered between 16' walls.

Secure wall with 2" screws into top and bottom plates (Fig. A, Fig. B).

Secure wall to bottom plate first.

⚠ ENSURE PANEL CORNERS ARE FLUSH. ⚠

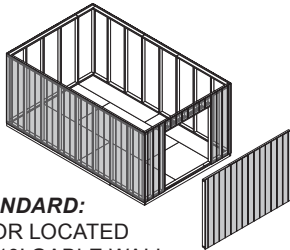

STANDARD:
DOOR LOCATED
ON 10' GABLE WALL

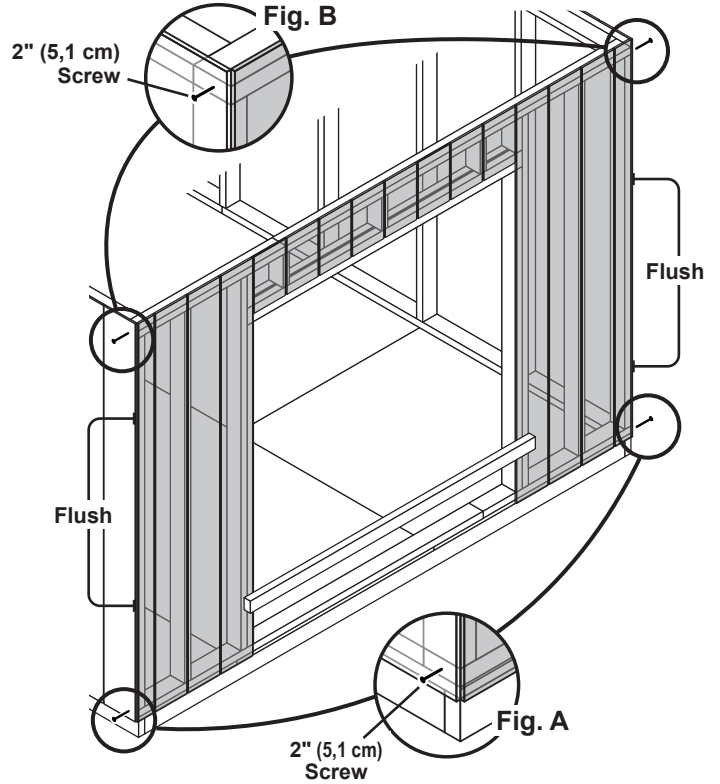

2 Nail lower edge of panels to floor with 2" nails spaced 6" apart. Angle nails into floor frame (Fig. C).

Nail panels to 10' wall studs with 1-1/2" nails spaced 6" apart.

3 Secure wall top plates with 3" screws at each corner at an angle (Fig. D).

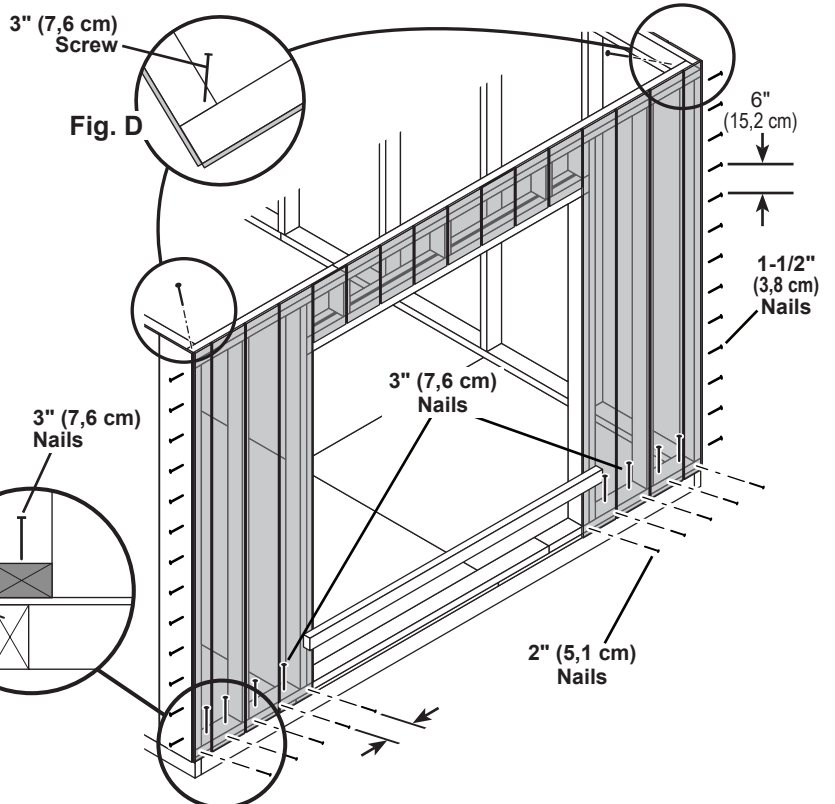

⚠ Nail 2" nails first.

Fig. C



FINISH

Your walls are now installed.

**CUT OUT AND REMOVE BOTTOM PLATE
AT DOOR OPENING.
REMOVE TEMPORARY BRACING.**

10' x 16' WALL DOUBLERS INSTALLATION

PARTS REQUIRED:

- x4 **SP**
2 x 4 x 48" (5,1 x 10,2 x 121,9 cm)
- x2 **JBD**
2 x 4 x 20-3/8" (5,1 x 10,2 x 51,8 cm)
- x2 **TJ**
2 x 4 x 92-5/8" (5,1 x 10,2 x 235,3 cm)
- x2 **TP**
2 x 4 x 96" (5,1 x 10,2 x 243,8 cm)

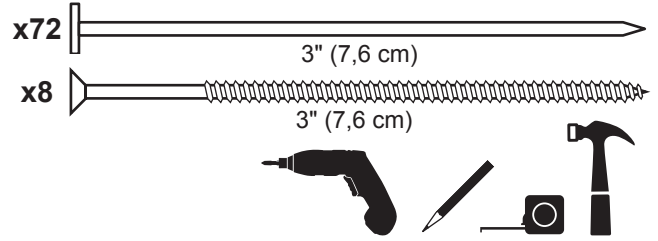

BEGIN

- 1 Orient parts on top of wall frames. Measure and mark from end of boards. Secure from top with (2) 3" nails spaced every 24" (Fig. A).
- 2 Secure from bottom with (2) 3" screws at each corner (Fig. B).
- 3 Secure from bottom with (2) 3" screws at each corner (Fig. B).

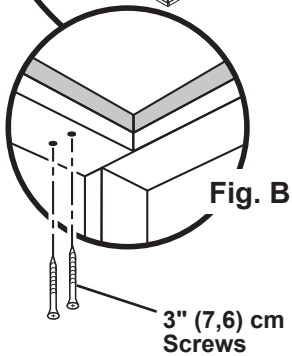
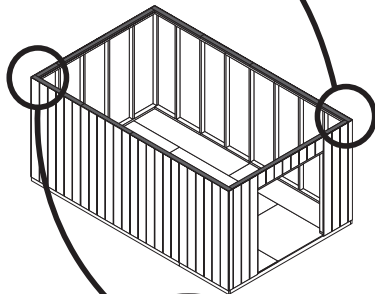
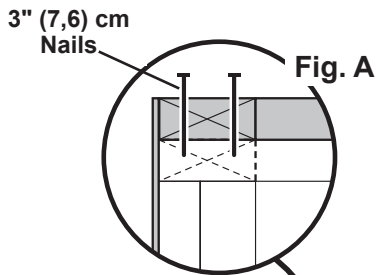

FINISH

Your wall doublers are now installed.

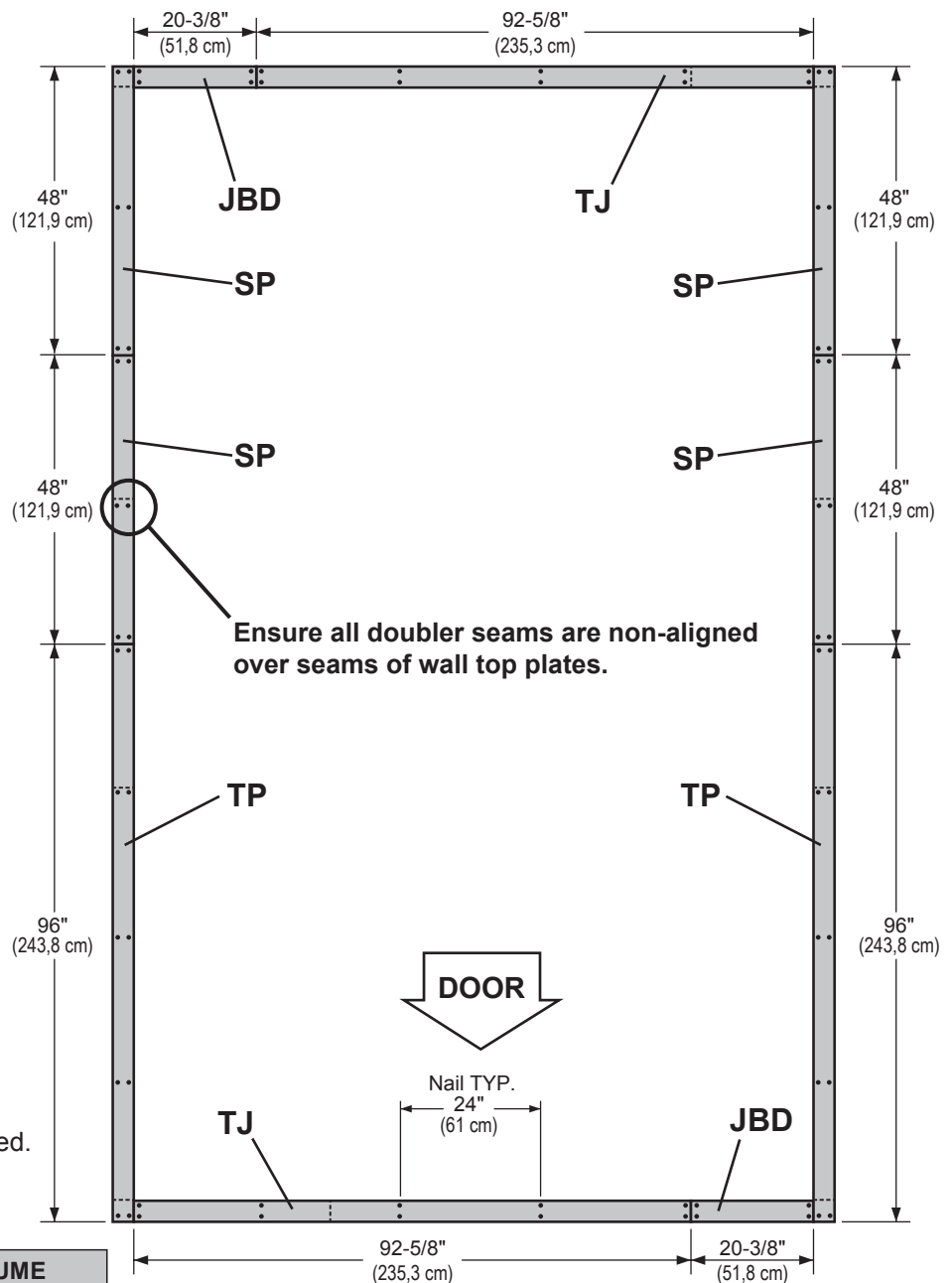

CONTINUE TO NEXT PAGE TO RESUME CONSTRUCTION OF 10' X 16' SHED.

10x12' 10x16'

RAFTERS

PARTS REQUIRED:

x1 **OO** Temporary Support
69" (175,3 cm) Door Stiffener

x12

x16

 6 x 24" (15,2 x 60,9 cm)

x14

x18

AD
 2 x 4 x 65" (5,1 x 10,2 x 165,1 cm)

x144

x192

 2" (5,1 cm)

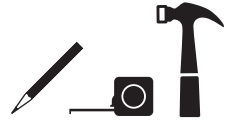

Build (2) rafter assemblies with (1) gusset (Fig. B).

✓ BEGIN

- Place two rafter-halves **AD** in the corner of back and side walls, flush to panels and studs.
Flush rafters at peak. Secure gusset to rafters with 2" nails following the pattern shown (Fig. A).

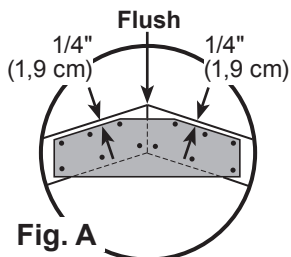

HINT:

Use floor and walls to help assemble rafters!

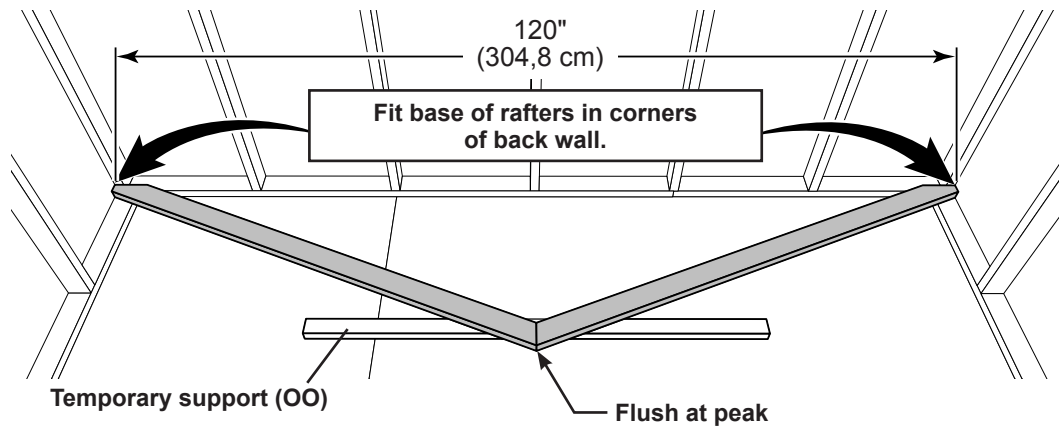

SET ASIDE THESE TWO RAFTER ASSEMBLIES.

Depending on your shed size, build 5 or 7 rafter assemblies with (2) gussets (Fig. C).

- Place two rafter-halves **AD** in the corner of back and side walls, flush to panels and studs (STEP - 1).
Flush rafters at peak. Secure gusset to rafters with 2" nails following the pattern shown (Fig. A).
- Flip over rafter assembly and fasten second gusset to other side with 2" nails (Fig. C).

Fig. B - Build 2

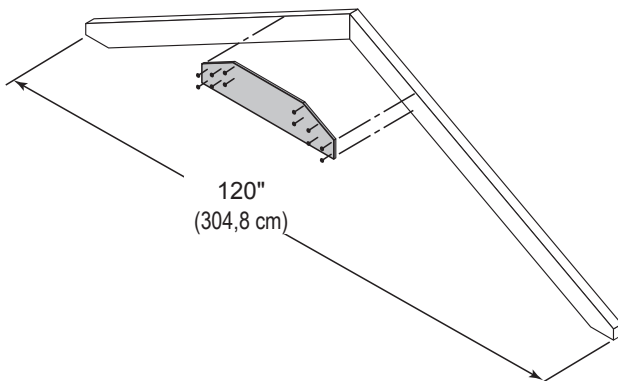
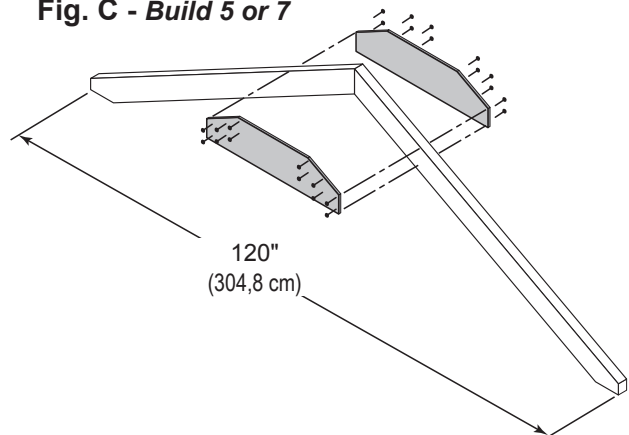

Fig. C - Build 5 or 7



Your rafters are now assembled.

10x12' 10x16' RAFTER INSTALLATION

PARTS REQUIRED:



x5
x2
x28

x7
x2
x36

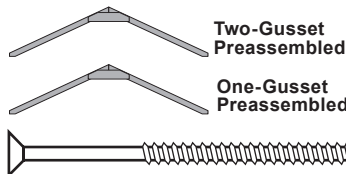

3" (7,6 cm)

BEGIN

1 Align rafters over the wall studs.



Check that you have the measurements shown.
Secure rafters with (2) 3" screws angled at each end (**Fig. A, Fig. B**).
Secure rafters on opposite side.

! *Maintain the measurements between rafters.*

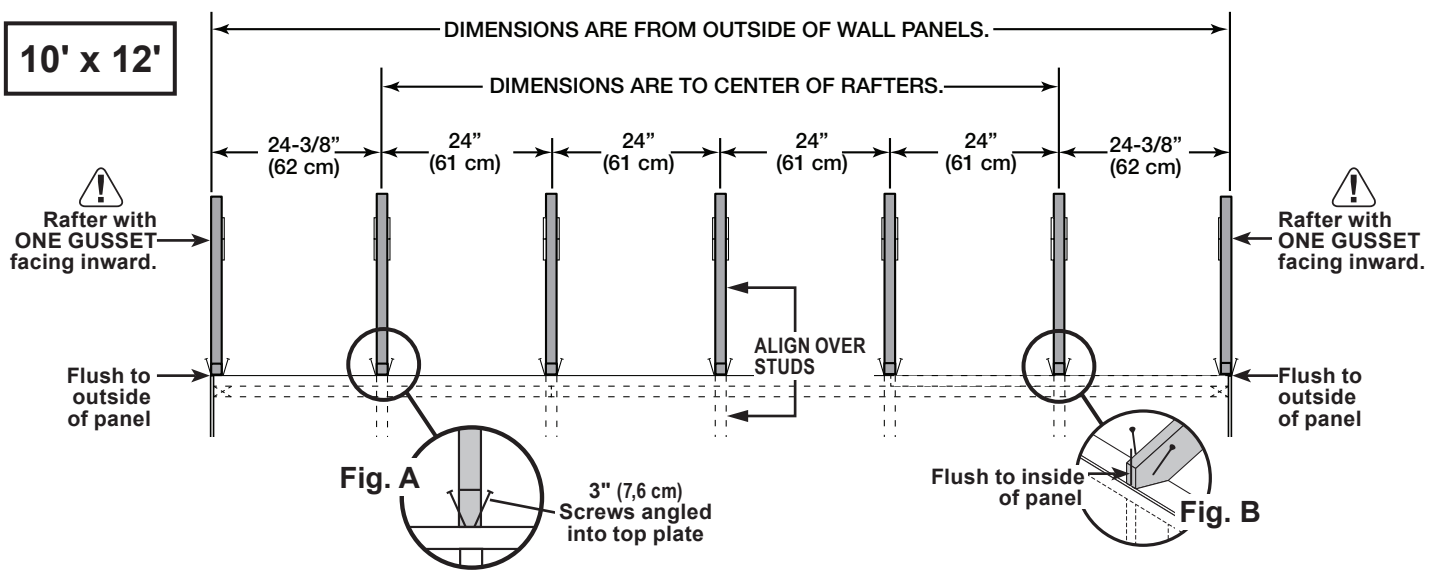

! *Maintain the measurements between rafters.*

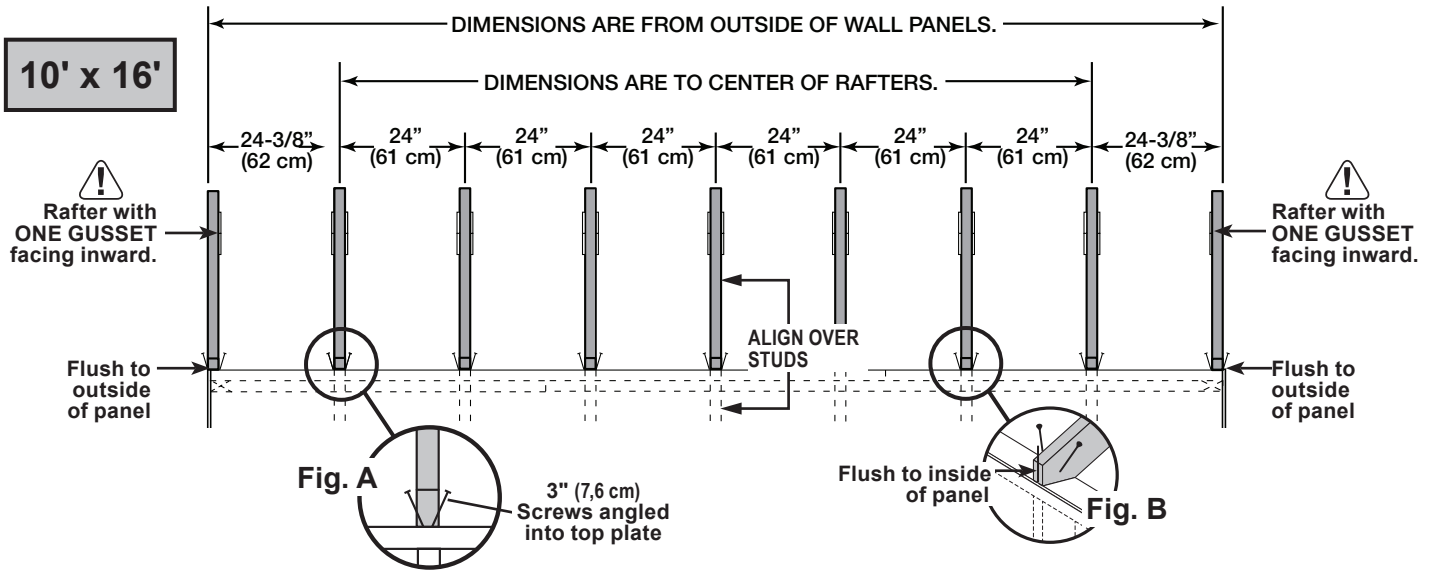

Your rafters are now installed.

GABLE UNITS

PARTS REQUIRED:

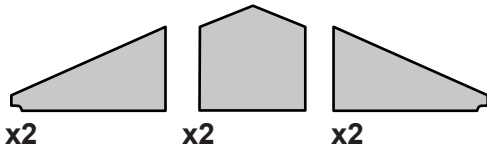

x4 **AF**
2 x 4 x 18-1/8" (5,1 x 10,2 x 46 cm)

x24 1-1/2" (3,8cm)

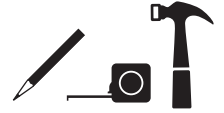

Install gable panels with the primed side facing up.

✓ BEGIN

- 1 Orient parts **AF** on the flat side, as shown.
Measure and mark the center of the middle gable panel. Secure with 1-1/2" nails spaced 6" apart along edge.
- 2 Place left panel on **AF** flush to installed gable panel and secure with 1-1/2" nails spaced 6" apart along edge.
Repeat STEP 2 for right panel.
Repeat STEPS 1 - 3 to build the 2nd gable unit.

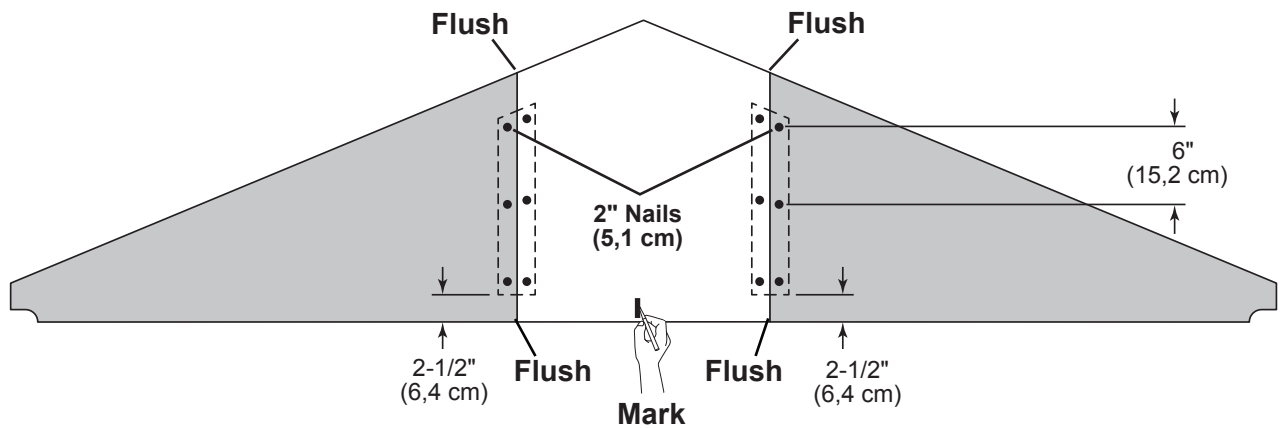
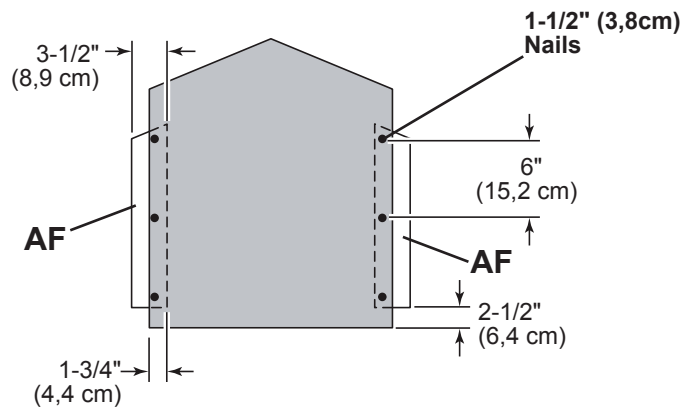

Your gable units are now installed.

GABLE INSTALLATION

PARTS REQUIRED:

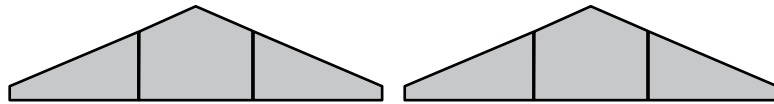

Pre - assembled

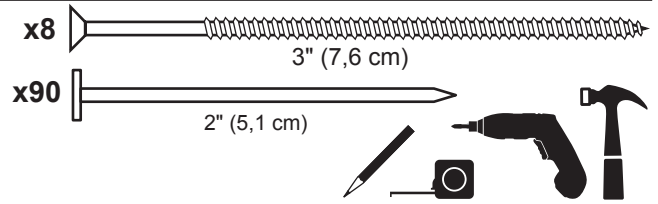

✓ BEGIN

- 1 Measure 2-9/16" down from top plate doubler and mark at each side as shown. Set gable unit on top plate. Fasten with (1) 2" nail on each side.

⚠ **BE SURE GABLE IS CENTERED ON WALL BEFORE NAILING.** ⚠

- 2 Continue nailing lower edge of panels to wall doubler with 2" nails spaced 6" apart.

- 3 Working inside, secure gable unit with (2) 3" screws angled into each AF at an angle (**Fig. A**).

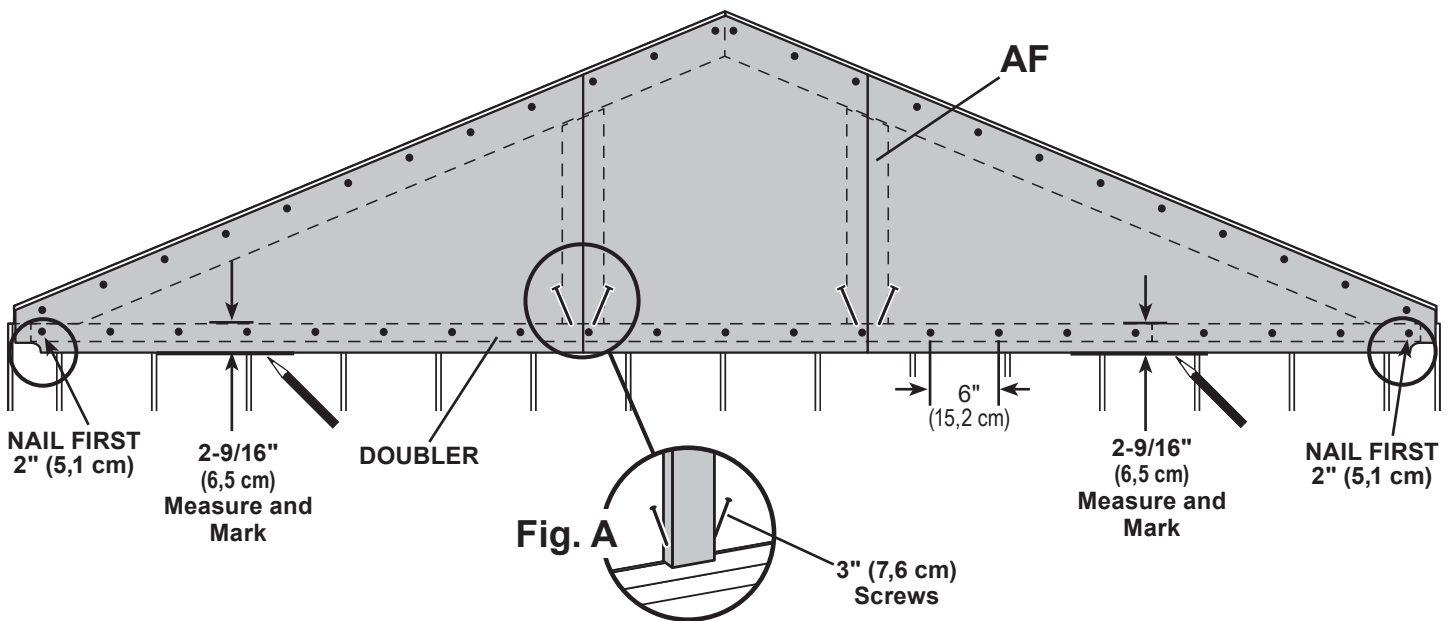

- 4 Continue securing panels to rafter with 2" nails spaced 6" apart.

Repeat STEPS 1 - 4 for the opposite side gable.



Your gable units are now installed

10' x 12' ROOF PANELS

PARTS REQUIRED:

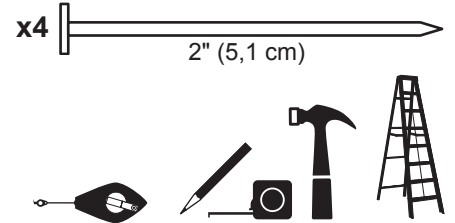

 **Roof panels may cause serious injury until securely fastened.**
Note: Install all roof panels with the rough side up (painted grid lines).

✓ **BEGIN**

- 1** Place the 48" x 96" panel on rafters with a 3/4" measurement on the rafter (Fig. A) and the panel flush at the peak (Fig. B).

Secure panel with (2) 2" nails in the corners.

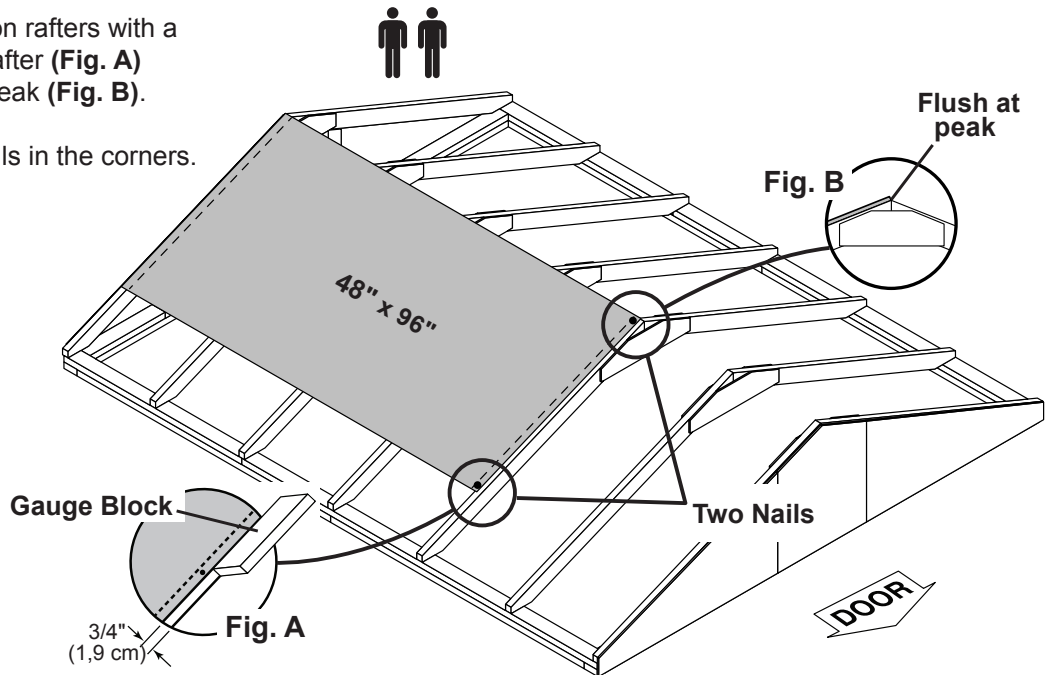

- 2** Move to the opposite end. Using the long edge of the panel as a lever, move the panel side-to-side until the top corner is flush to the peak (Fig. B) and there is a 1/2" measurement on the gable end rafter (Fig. C).

Secure panel with (2) 2" nails in the corners.

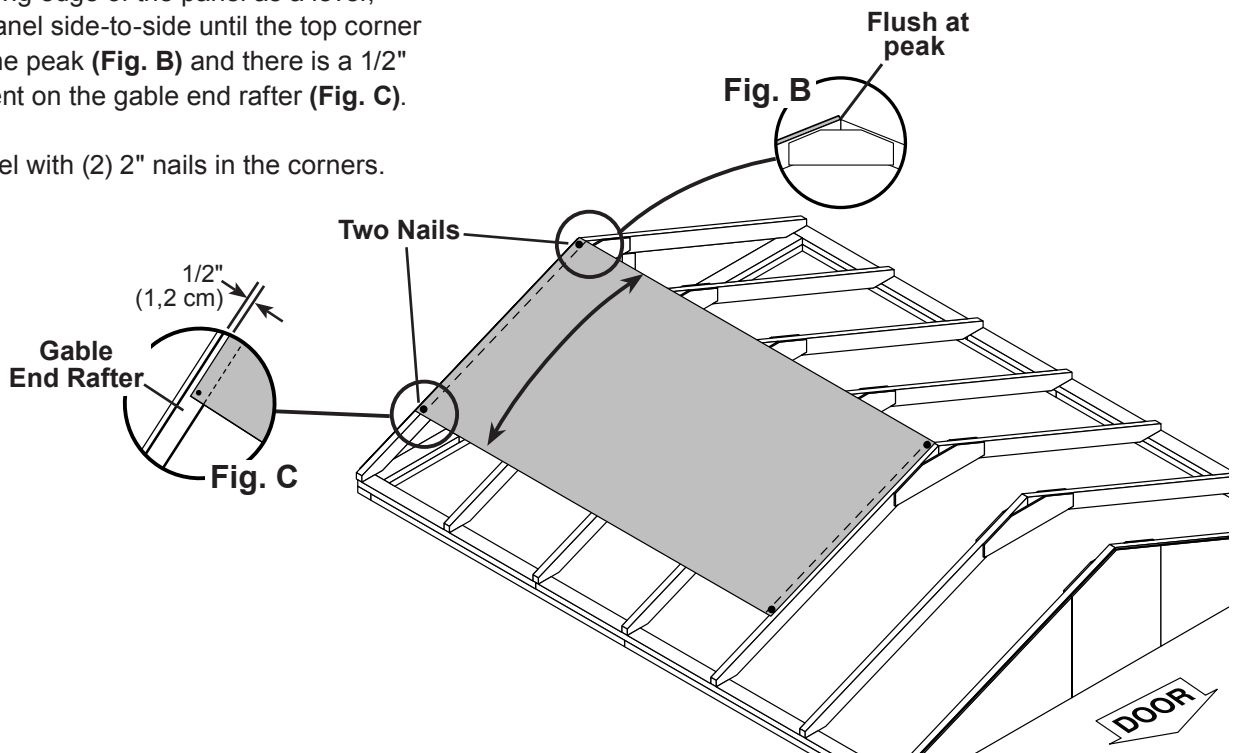

10' x 12' ROOF PANELS

PARTS REQUIRED:

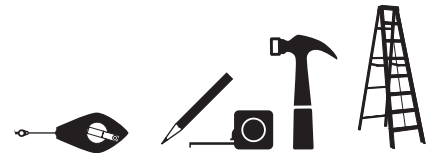
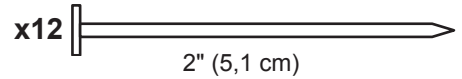
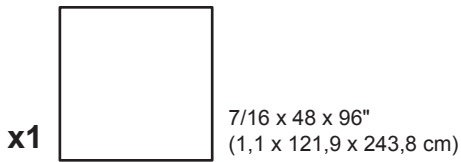

- 3** Install a 48" x 47-7/8" roof panel flush to the installed panel and flush at peak (**Fig. B**).

Secure panel with (1) 2" nail in each corner.

- 4** Move the gable end rafter edge until it is 1/2" from the 48" x 47-7/8" roof panel (**Fig. C**).

Finish securing panel with (2) 2" nails in the corners.

- 5** Maintain spacing between the center of the rafters at the lower edge of the panels (**Fig. D**).

Secure panels with (1) 2" nail into each rafter, as shown.

Move to the top of the panel and keep spacing between the center of the rafters.

Secure panels with (1) 2" nail into each rafter.

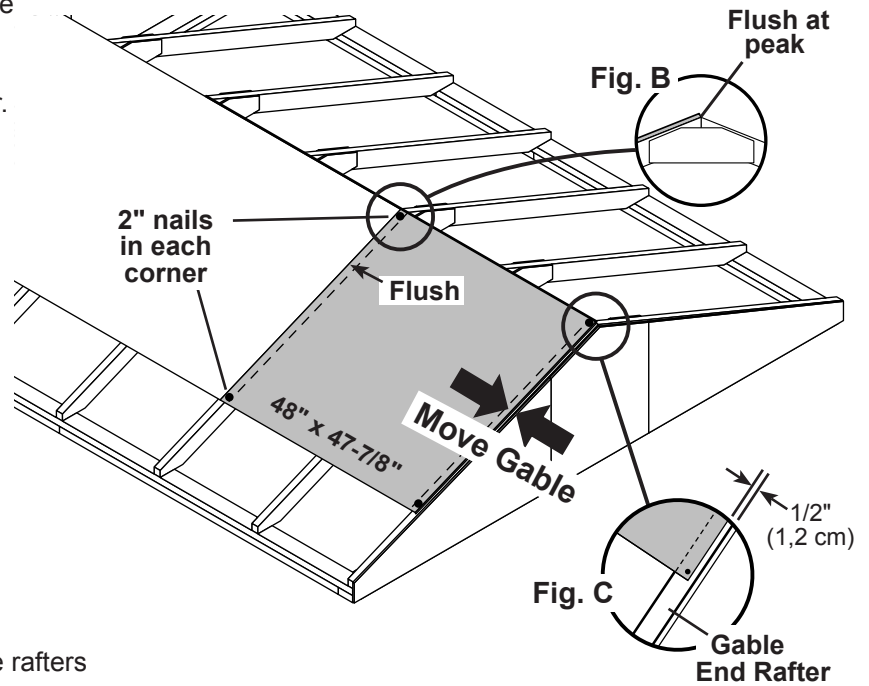
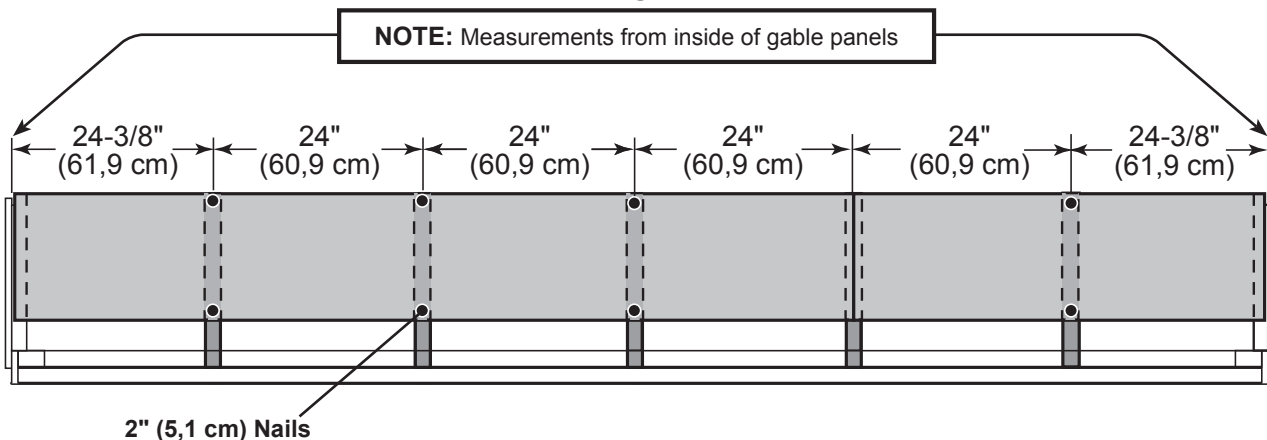



Fig. D



10' x 12' ROOF PANELS

PARTS REQUIRED:

x1  23-1/2" x 47-7/8"
(59,7 x 121,9 cm)

x1  23-1/2" x 96"
(59,7 x 243,8 cm)

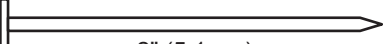

3/4" GAUGE
BLOCK

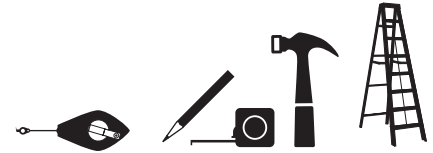
x8  2" (5,1 cm)

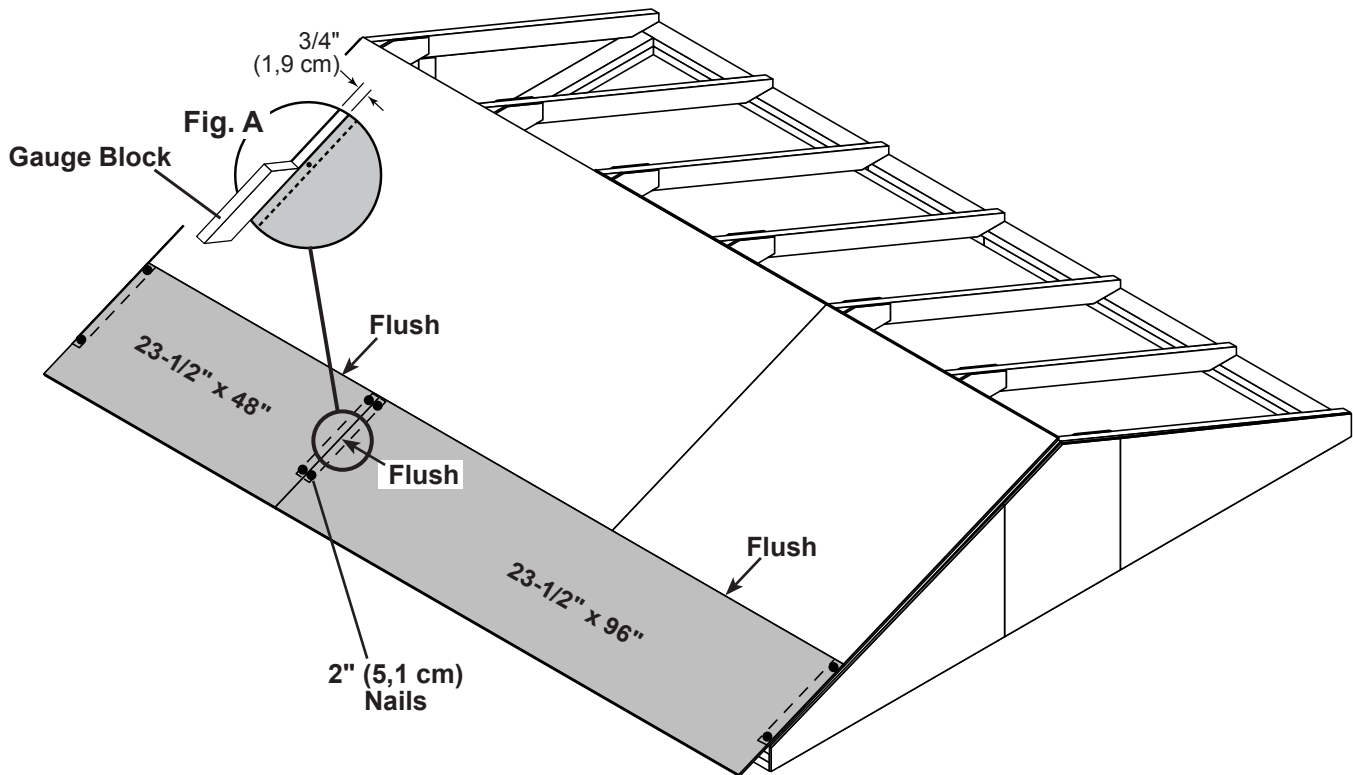

- 6** Install 23-7/8" x 48" and 13-7/8" x 96" roof panels with a 3/4" measurement on the rafter (Fig A) and flush to the installed panels.

Secure panels with (1) 2" nail in each corner.



10' x 12' ROOF PANELS

PARTS REQUIRED:

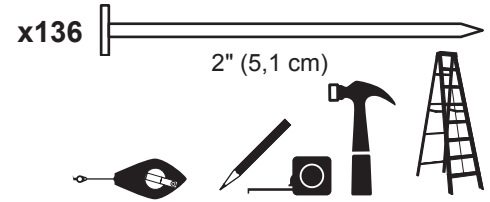

- 7** Secure all roof panels with 2" nails spaced 6" apart and 12" apart inside of the 48" wide panels.

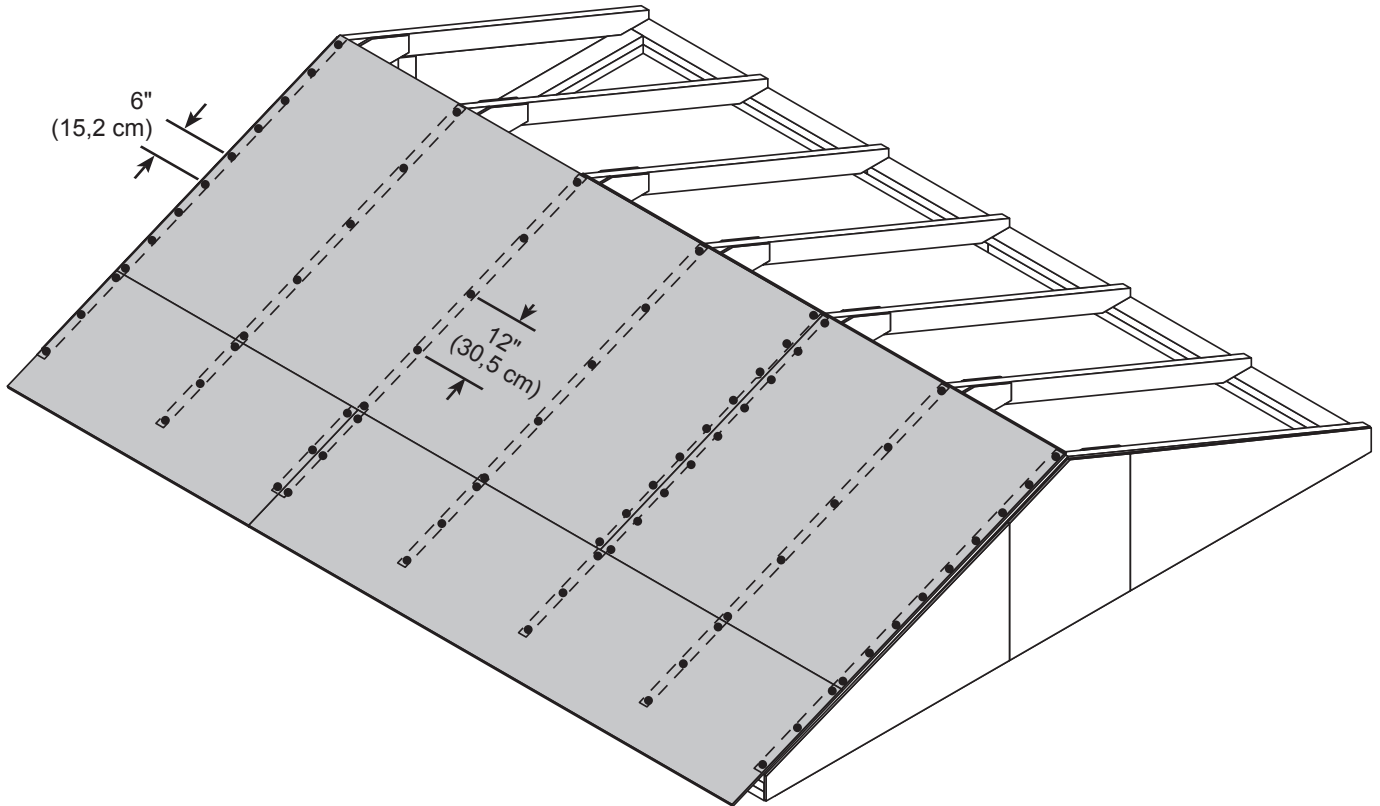

Repeat steps to install roof panels on the opposite side.

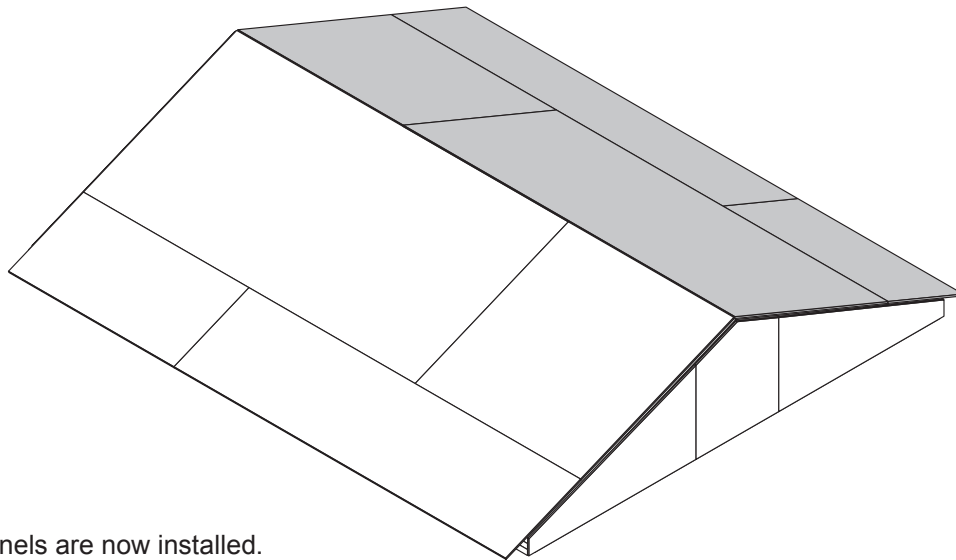

Your roof panels are now installed.

10' x 16' ROOF PANELS

PARTS REQUIRED:

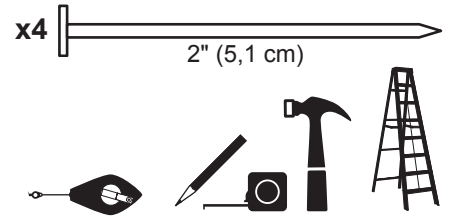

 **Roof panels may cause serious injury until securely fastened.**
Note: Install all roof panels with the rough side up (painted grid lines).

✓ **BEGIN**

1

Place the **48" x 96"** panel on rafters with a 3/4" measurement on the rafter (**Fig. A**) and the panel flush at the peak (**Fig. B**).

Secure panel with (2) 2" nails in the corners.

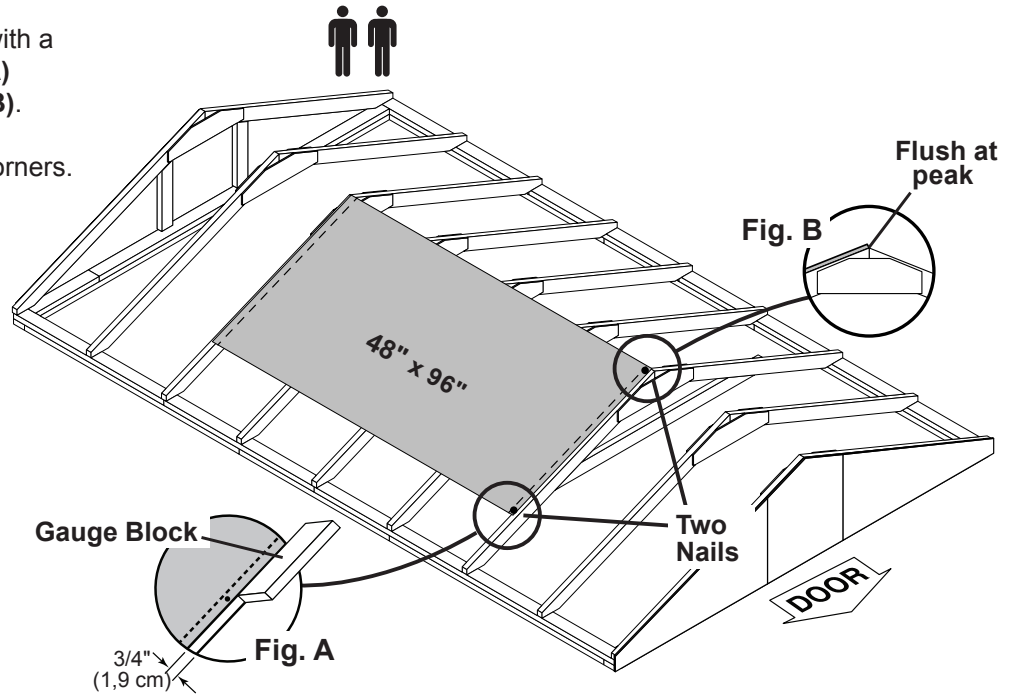

2

Move to the opposite end.
Using the long edge of the panel as a lever, move the panel side-to-side until the top corner is flush to the peak (**Fig. B**) and there is a 3/4" measurement on the rafter (**Fig. C**).

Secure panel with (2) 2" nails in the corners.

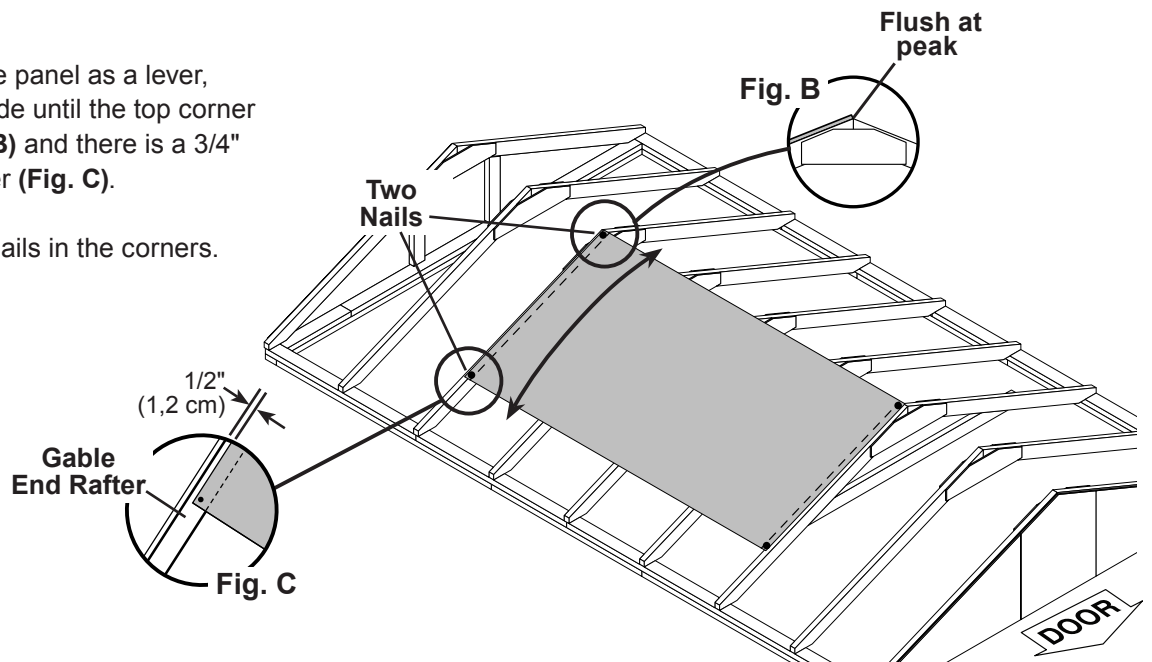

10' x 16' ROOF PANELS

PARTS REQUIRED:

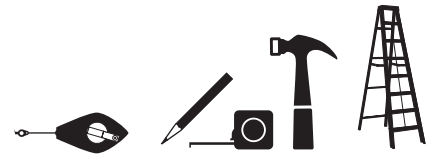
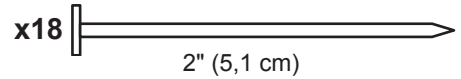
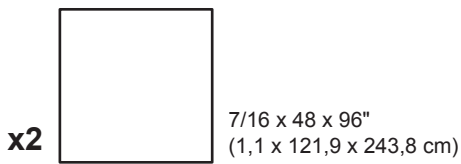

3
Install 48" x 47-7/8" roof panel flush to the installed panel and flush at the peak (Fig. B).

Secure panel with (1) 2" nail in each corner, as shown.

4
Move gable end rafter edge until it is 1/2" from the 48" x 47-7/8" roof panel (Fig. C).

Finish securing panel with (1) 2" nail in the outside corners.

Repeat STEPS 3 - 4 to install the 2nd 48" x 47-7/8" roof panel, as shown.

5
Maintain spacing between the center of the rafters at the lower edge of the panels (Fig. D).

Secure panels with (1) 2" nail into each rafter, as shown.

Move to the top of the panel and keep spacing between the center of the rafters.

Secure panels with (1) 2" nail into each rafter.

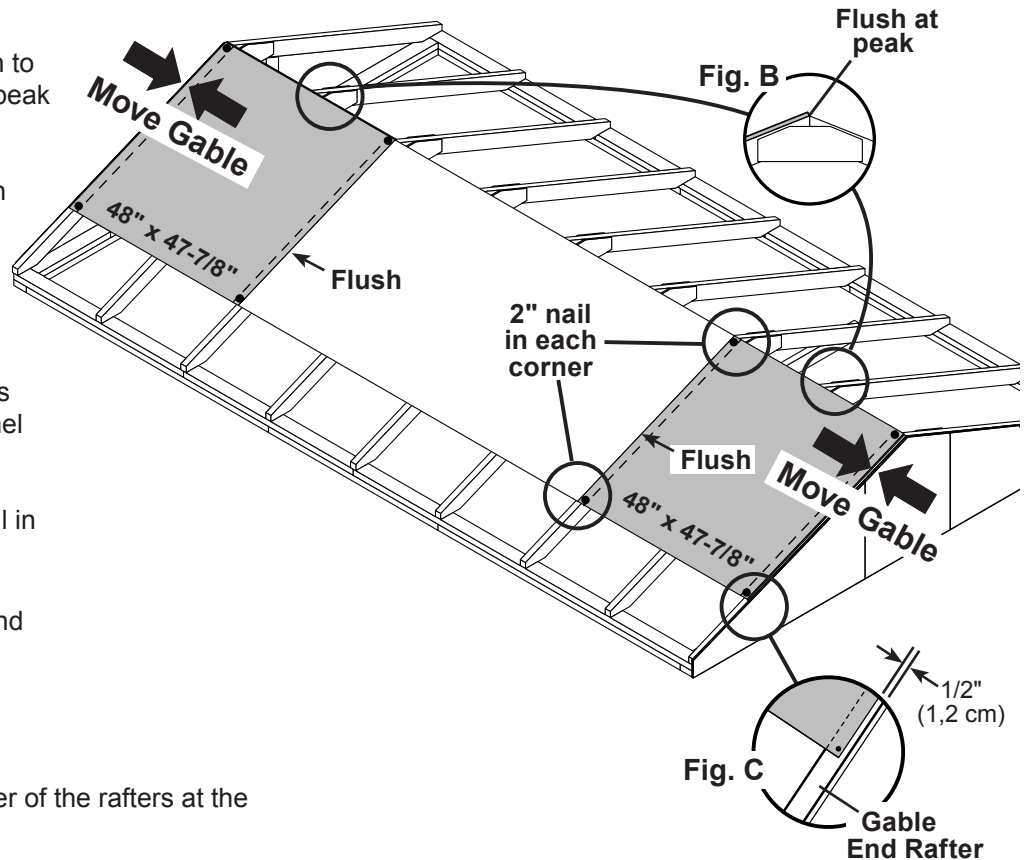
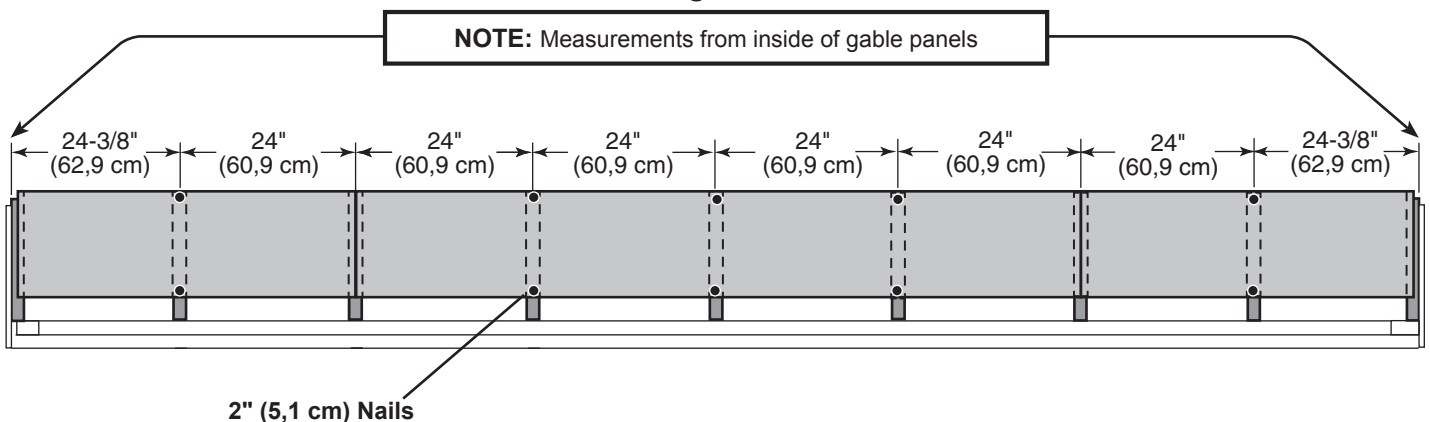



Fig. D



10' x 16' ROOF PANELS

PARTS REQUIRED:

x1  23-1/2" x 48"
(59,7 x 121,9 cm)

x1  23-1/2" x 96"
(59,7 x 243,8 cm)

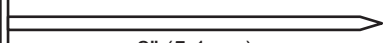

3/4" GAUGE
BLOCK

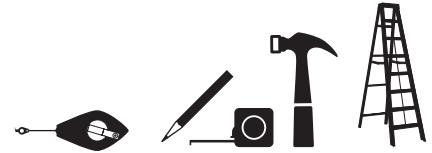
x12  2" (5,1 cm)

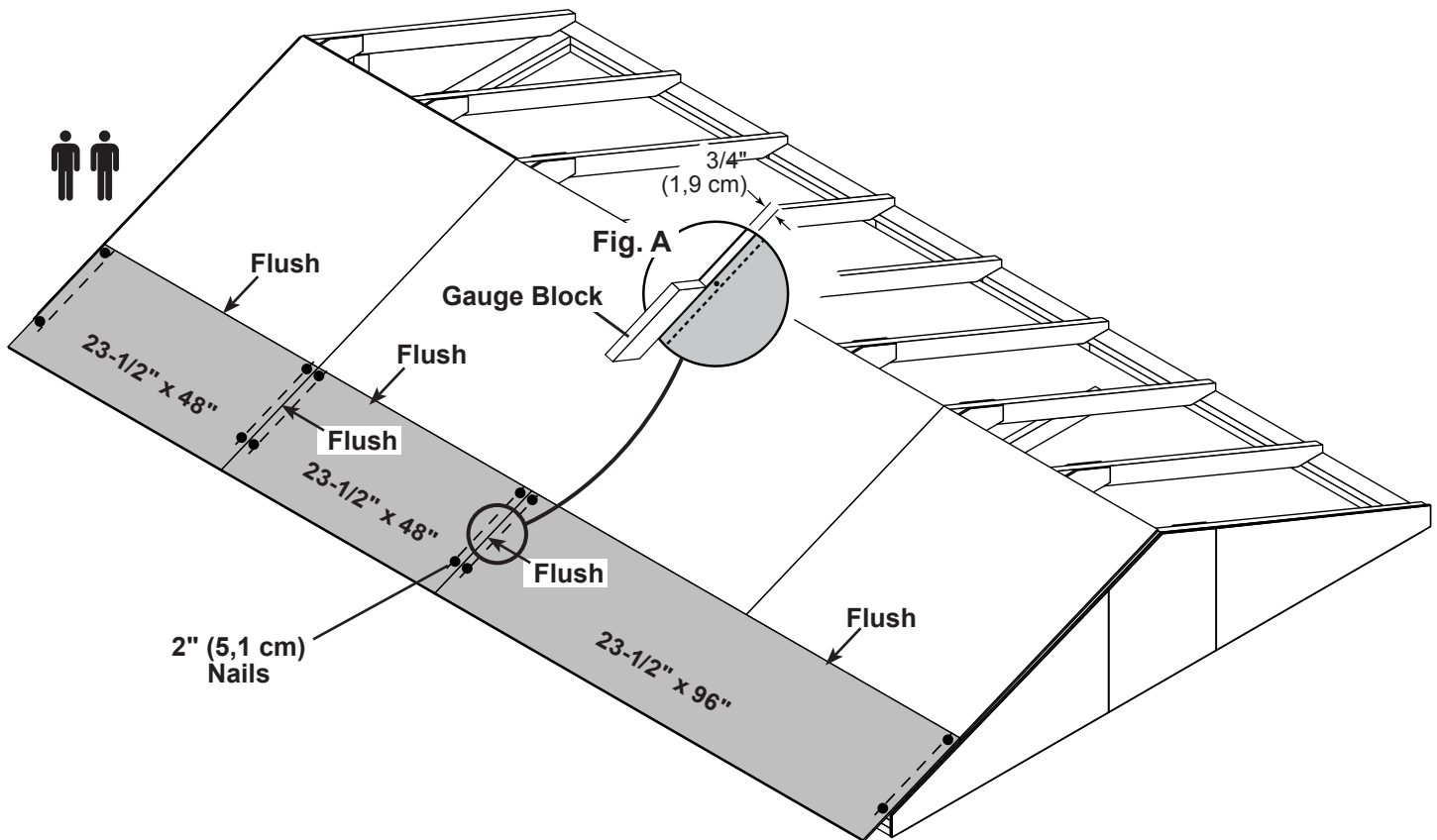

6 Install 23-7/8" x 96" roof panel with a 3/4" measurement on the rafter (Fig A) and flush to the upper installed panels.
Secure panels with (1) 2" nail in each corner.

7 Install (2) 23-7/8" x 48" roof panels flush to the installed panels.
Secure panels with (1) 2" nail in each corner.



10' x 16' ROOF PANELS

PARTS REQUIRED:

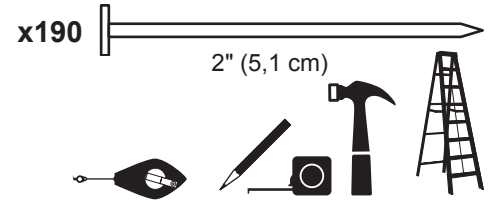

- 8 Secure all roof panels with 2" nails spaced 6" apart and 12" apart inside of the panels.

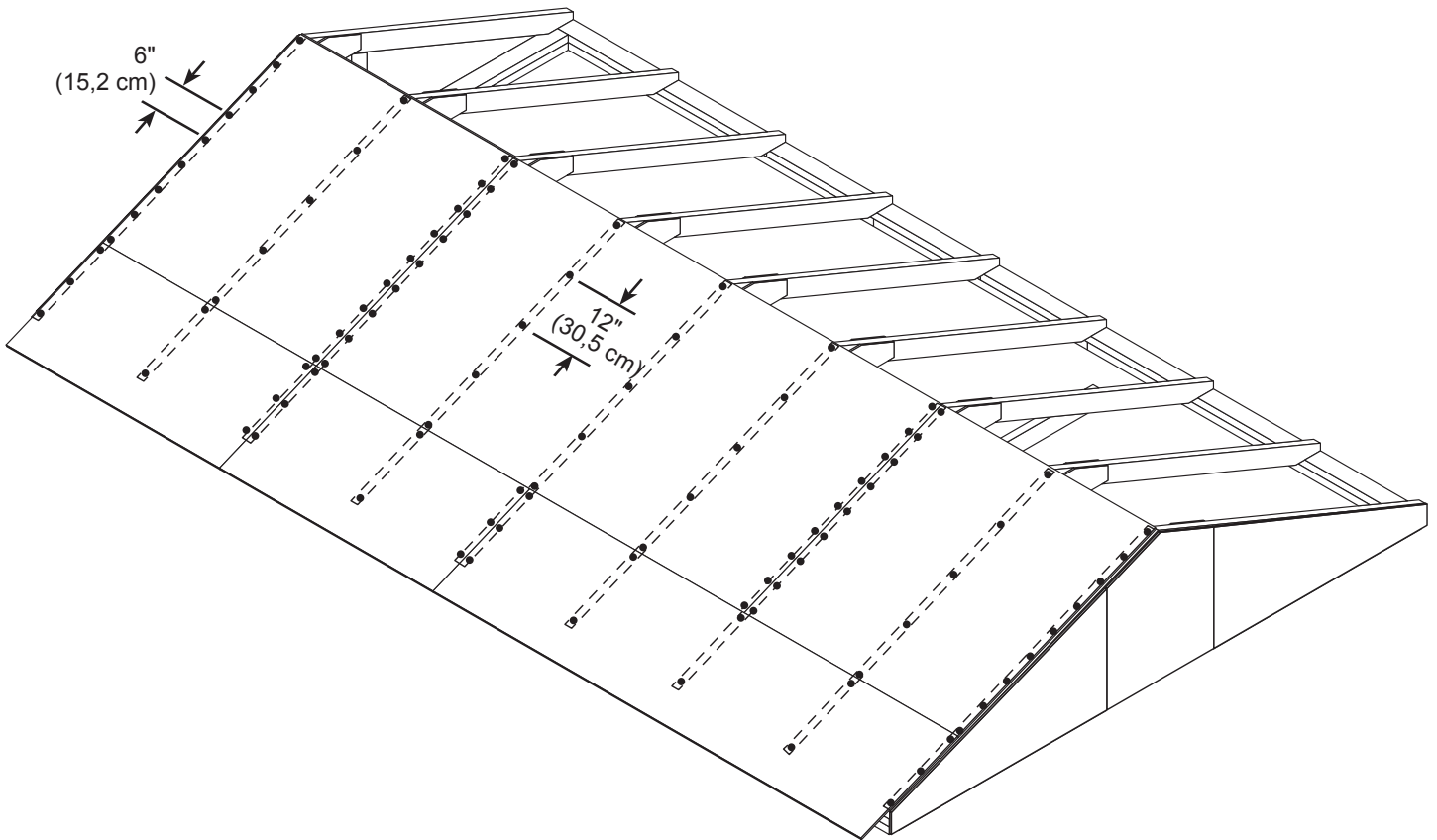

Repeat all steps to install roof panels on the opposite side.

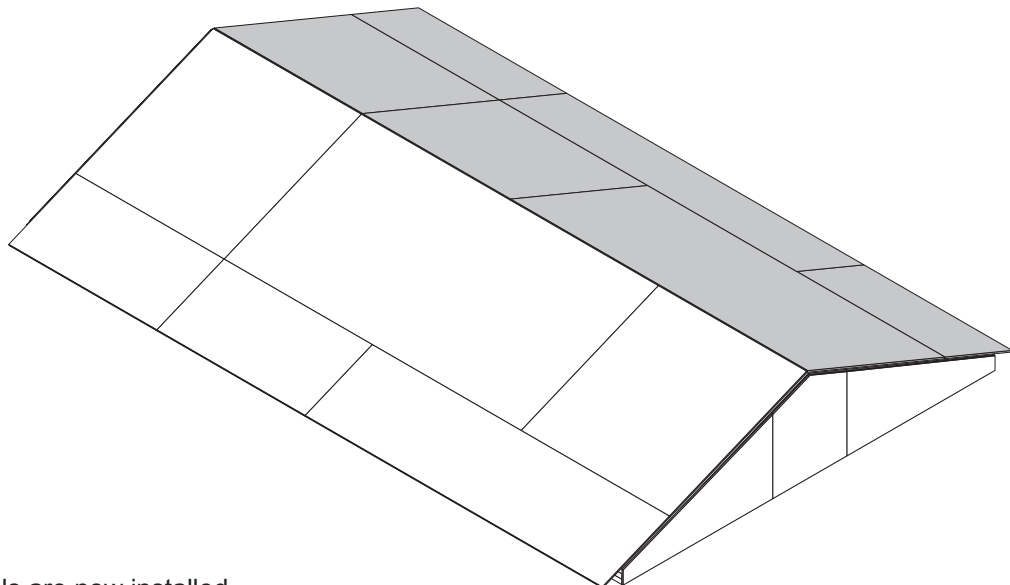

Your roof panels are now installed.

GABLE TRIM

PARTS REQUIRED:

- x2 **AUR**
19/32" x 3-1/2" x 71-15/16" (1,5 x 8,9 x 182,7 cm)
- x2 **AUL**
19/32" x 3-1/2" x 71-15/16" (1,5 x 8,9 x 182,7 cm)

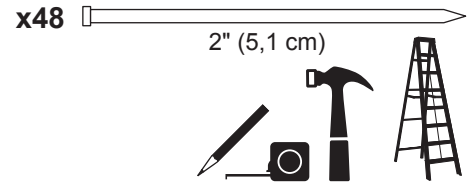

✓ BEGIN

- 1 Install front gable trim **AUR** and **AUL** flush to top of roof panel and flush at peak, as shown (**Fig. A**).
Secure trim with 2" finishing nails 7-1/4" apart.

Repeat above steps to secure the back wall gable trim.

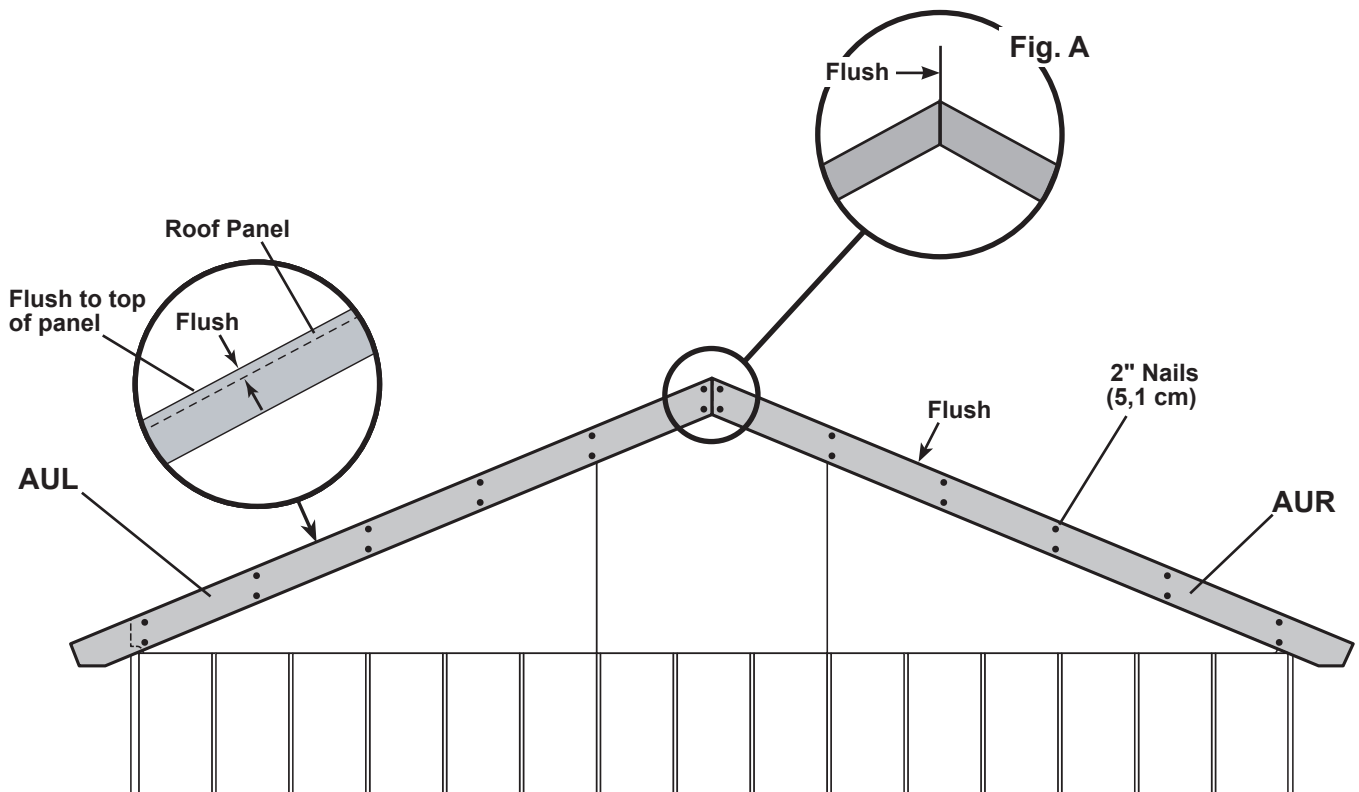

Your gable trim is now installed.

10' x 12' EAVE TRIM

PARTS REQUIRED:

x2 **WTC**
2 x 6 x 49-3/4" (5,1 x 15,2 x 126,4 cm)

x2 **VX**
2 x 6 x 96" (5,1 x 15,2 x 243,8 cm)

x8  3" (7,6 cm) x62  1-1/4" (3,2 cm)

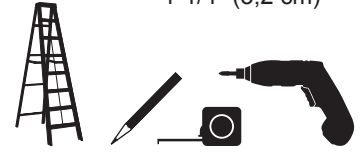

✓ BEGIN



1 Place **VX** eave trim flush along edge of roof panel (**Fig. A**).
Screw through roof panel into **VX** with 1-1/4" screws spaced approximately 7-1/2" apart, as shown.

2 Install **WTC** flush to edge of roof panel and flush to installed eave trim **VX**.
Screw through roof panel into **WTC** with 1-1/4" screws spaced approximately 7-1/2" apart, as shown. ****Part WTC may need to be trimmed to fit****

Repeat installation on opposite side.

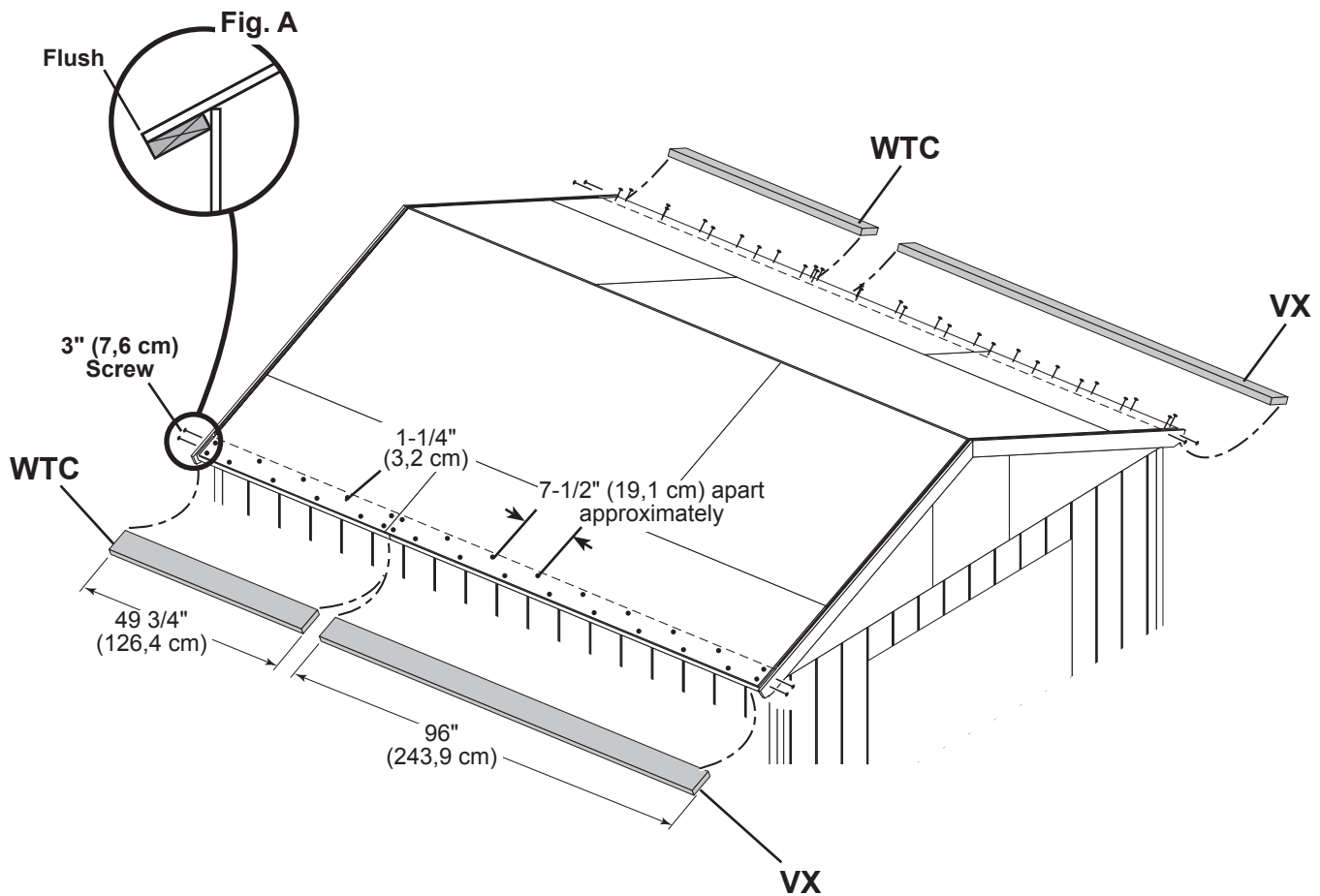

Your eave trim is now installed.

10' x 16' EAVE TRIM

PARTS REQUIRED:

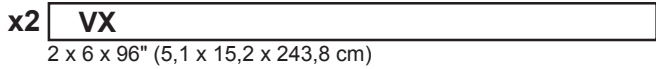
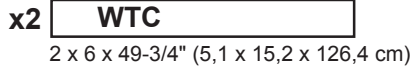
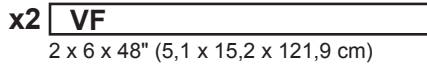

✓ **BEGIN**



- 1 Place **VF** eave trim flush along edge of roof panel (**Fig. A**).
Screw through roof panel into **VX** with 1-1/4" screws spaced approximately 7-1/2" apart, as shown.

****Part WTC may need to be trimmed to fit****

- 2 Install **WTC** flush to edge of roof panel and flush to installed eave trim **VX**.
Screw through roof panel into **WTC** with 1-1/4" screws spaced approximately 7-1/2" apart, as shown.

- 3 Install **VF** flush to edge of roof panel and flush to installed eave trim **WTC**.
Screw through roof panel into **VF** with 1-1/4" screws spaced approximately 7-1/2" apart, as shown.

Repeat installation on opposite side.

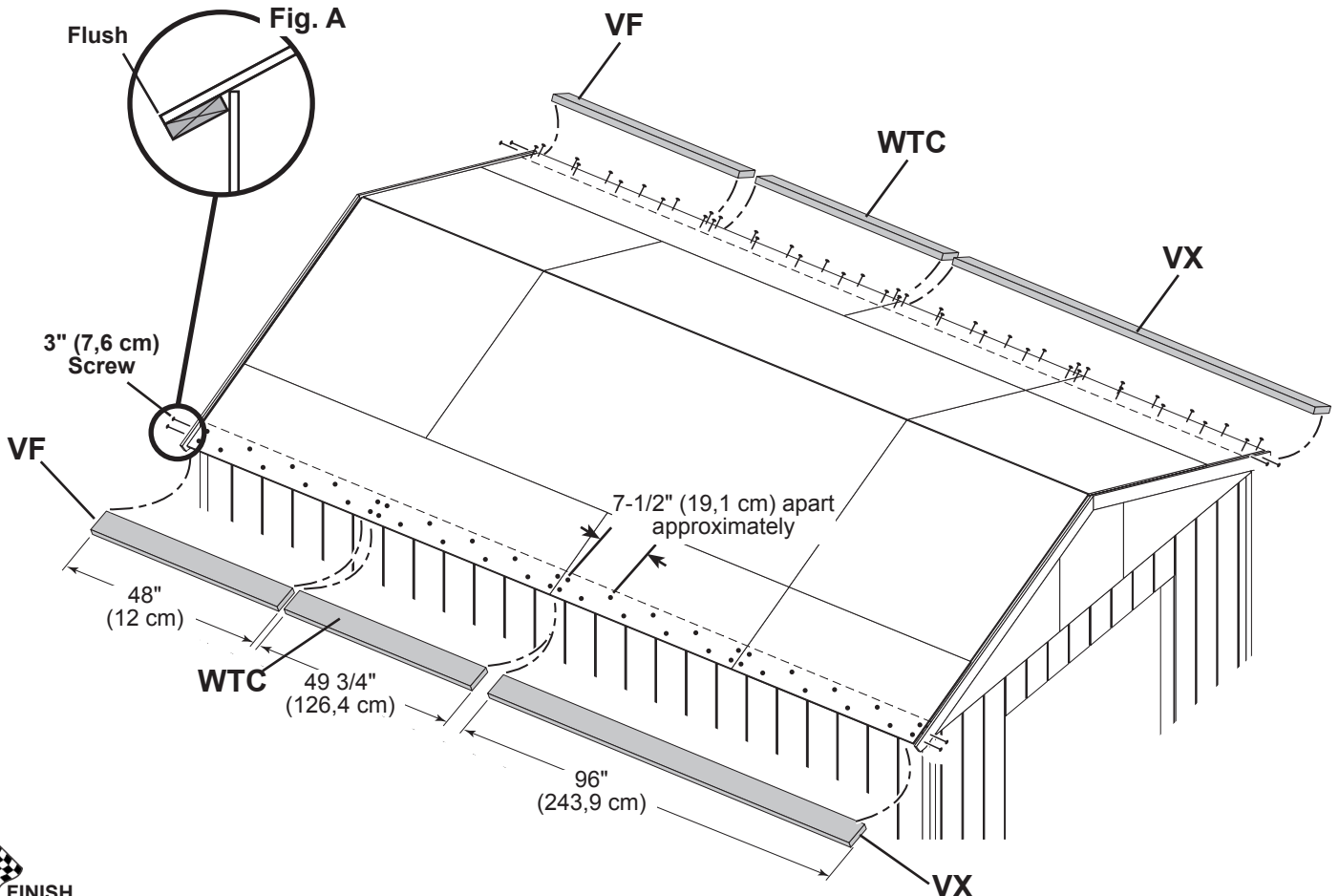

Your eave trim is now installed.

CORNER TRIM

PARTS REQUIRED:

x8 
3/8" x 1-3/4" x 83-1/2" (1 x 4,5 x 212,1cm)

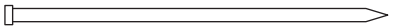
x64 
2" (5,1 cm)



✓ BEGIN

- 1 Install gable end **83-1/2"** corner trim under gable panel, (**Fig. A**) and flush to eave wall panel (**Fig. B**). Secure with 2" finishing nails spaced evenly.
- 2 Install eave side **83-1/2"** corner trim flush to eave soffit and flush along seam of installed corner trim (**Fig. C**). Secure with 2" finishing nails spaced evenly.

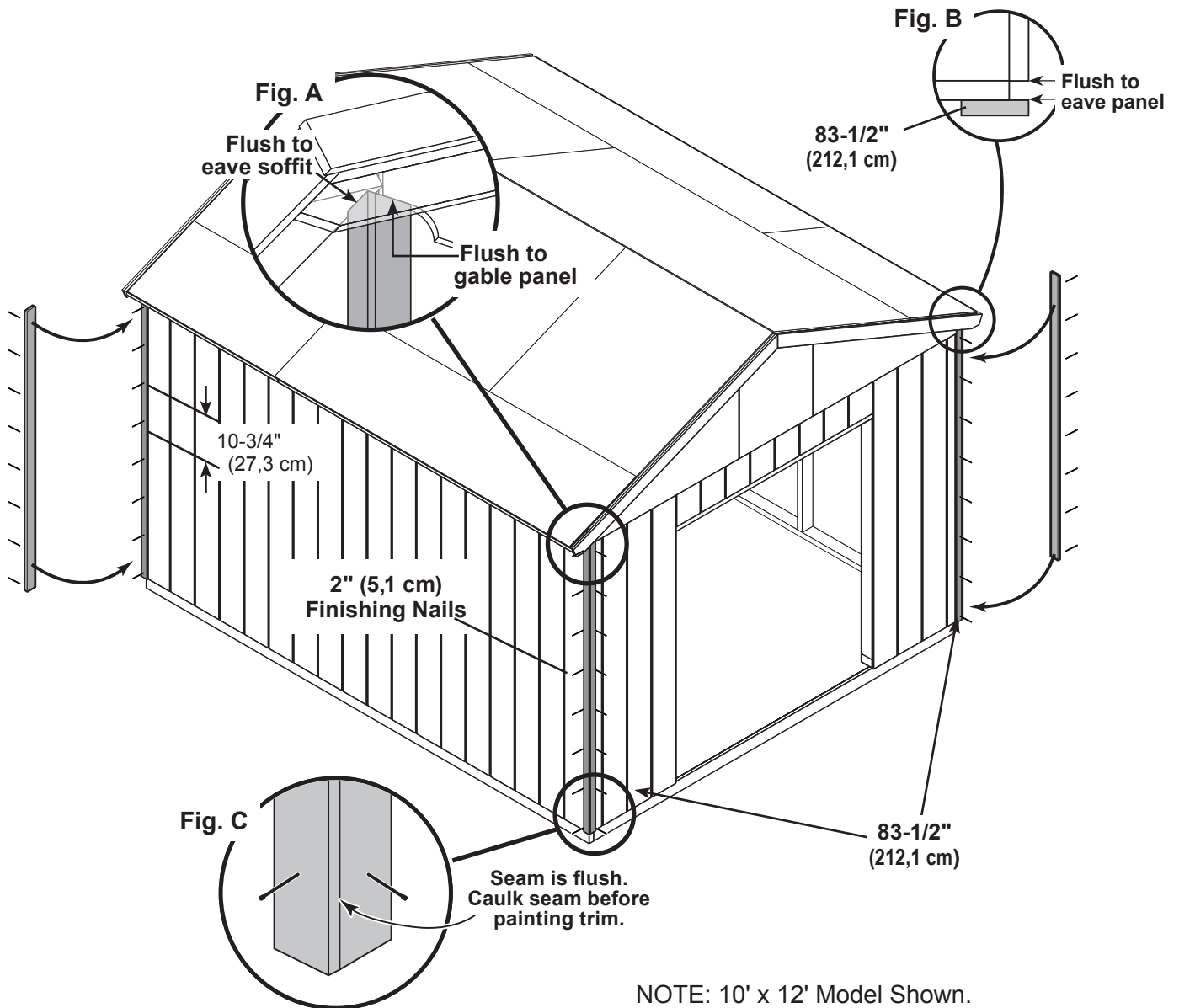

Repeat STEPS 1 - 2 for each corner of shed.



Your corner trim is now installed.

10' x 12' COLLAR TIE

PARTS REQUIRED:

x2 **TM**
2 x 4 x 72" (5,1 x 10,2 x 182,9 cm)

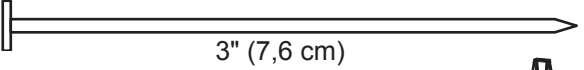
x12  3" (7,6 cm)

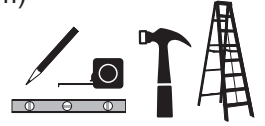

✓ **BEGIN**

1 Install collar tie **TM** to the 3rd and 5th rafters from the front with (3) 3" nails at each end.

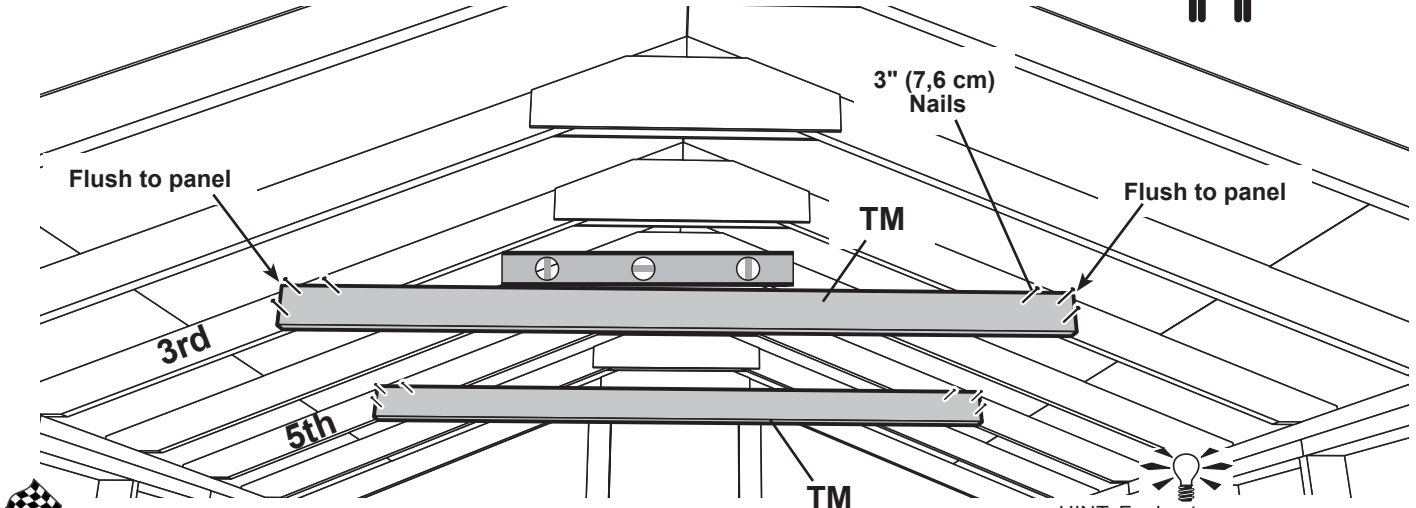

FINISH
Your collar tie is now installed.

HINT: For best appearance, install collar tie on back side of rafter.

10' x 16' COLLAR TIES

PARTS REQUIRED:

x3 **TM**
2 x 4 x 72" (5,1 x 10,2 x 182,9 cm)

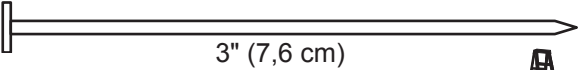
x18  3" (7,6 cm)

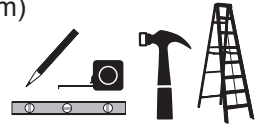

✓ **BEGIN**

1 Install (2) collar ties **TM** to the 3rd, 5th and 7th rafters from the front with (3) 3" nails at each end.

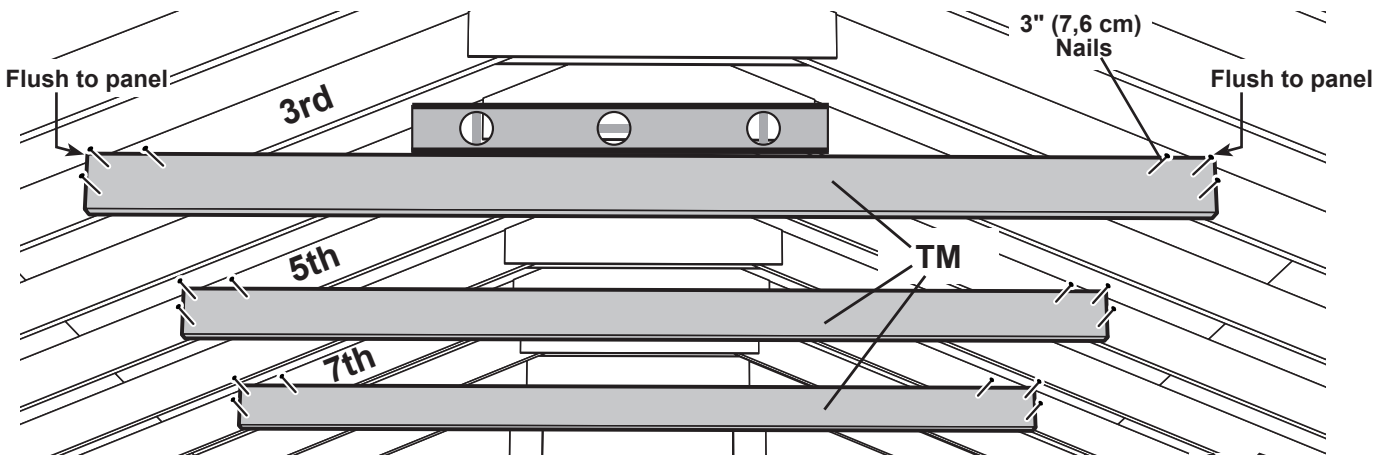

FINISH
Your collar ties are now installed.

HINT: For best appearance, install collar tie on back side of rafter.

DOORS

PARTS REQUIRED:

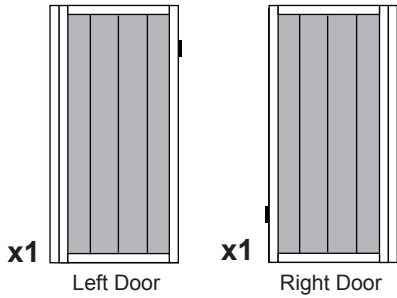

x1 **GAA**
1 x 3 x 5" (2,5 x 7,6 x 12,7 cm)

x1 **OO**
69" (175,3 cm) Door Stiffener

x4 3" (7,6 cm)

x2 1-1/4" (3,2 cm)

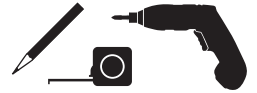

✓ BEGIN

- 1 Place doors on flat surface. **3/8" offset is to top.**
Look for red (right) and green (left) on hinge board.

Attach temporary supports **OO** and **GAA** as shown.

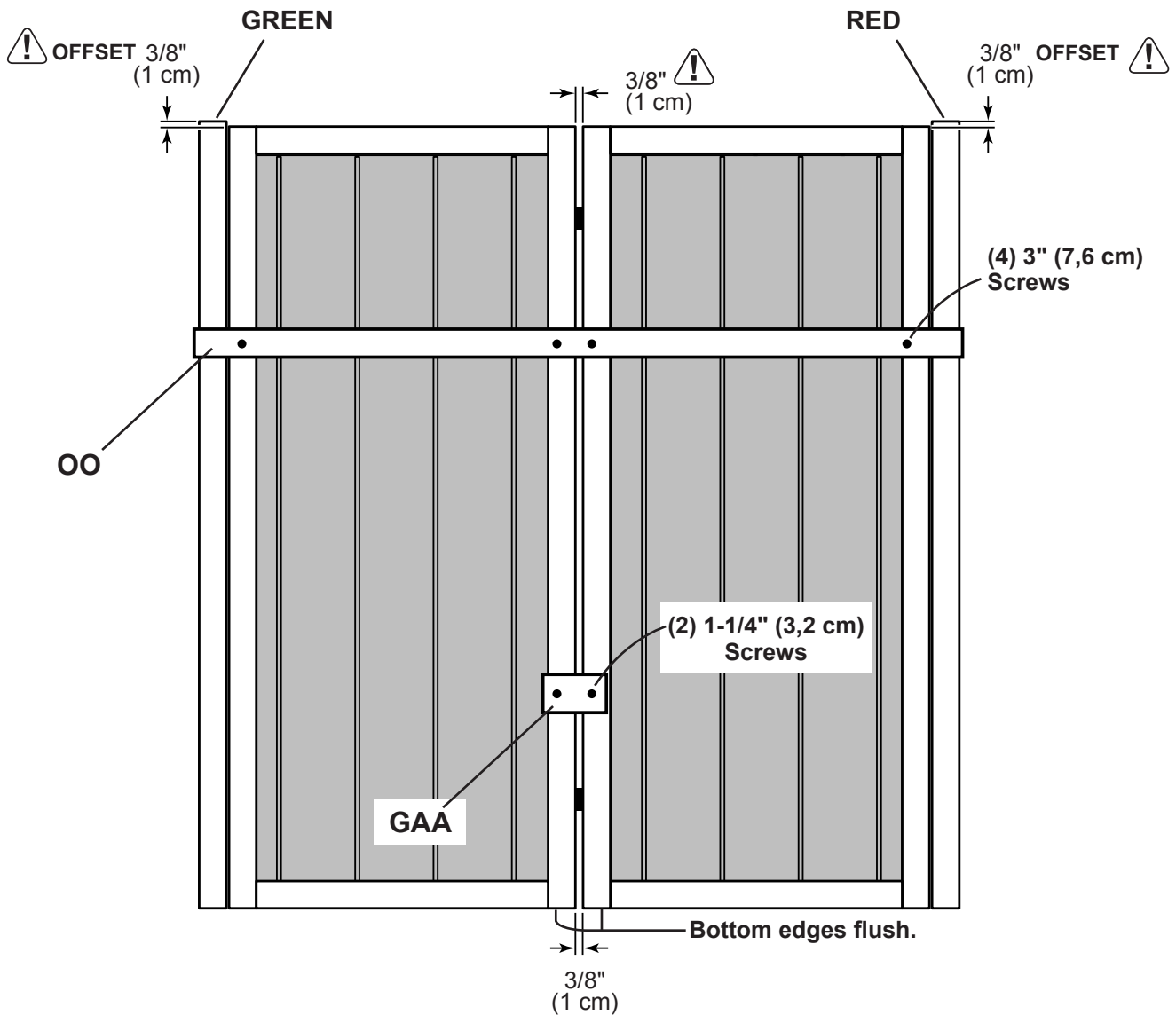

DOORS

PARTS REQUIRED:

x1 **OO** *TEMPORARY SUPPORT*
69" (175,3 cm) Door Stiffener

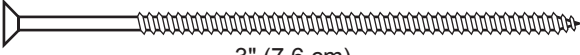
x12  3" (7,6 cm)

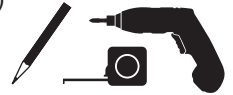

- 2 Install **OO** flush under panels.
Secure to floor frame with (2) 3" screws (**Fig. A**).
Mark center of door opening.

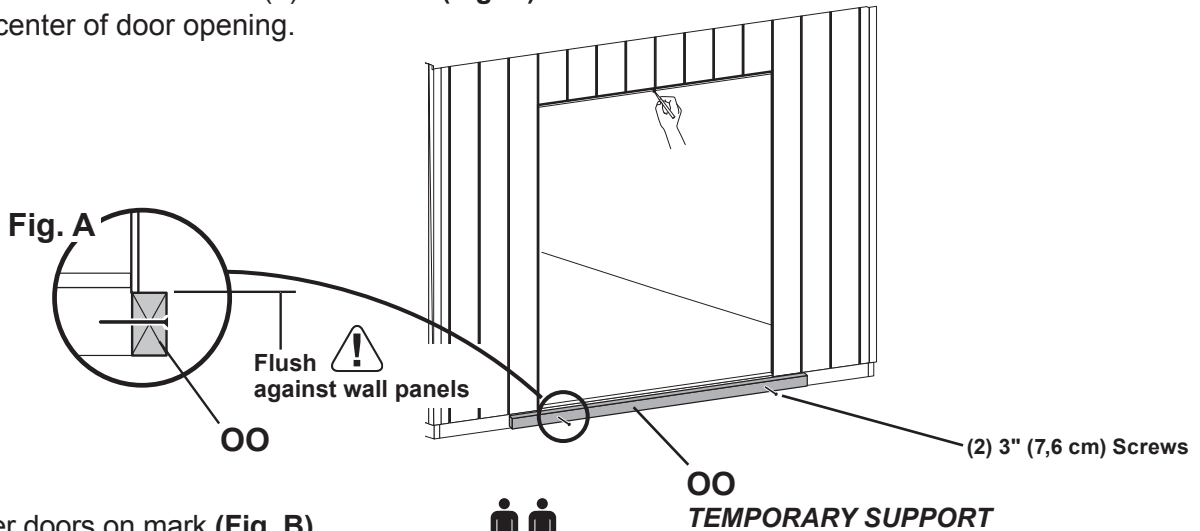

- 3 Center doors on mark (**Fig. B**). 

- 4 Screw hinge boards into wall supports with (10) 3" screws, as shown.
 **Make sure screws go into framing.**

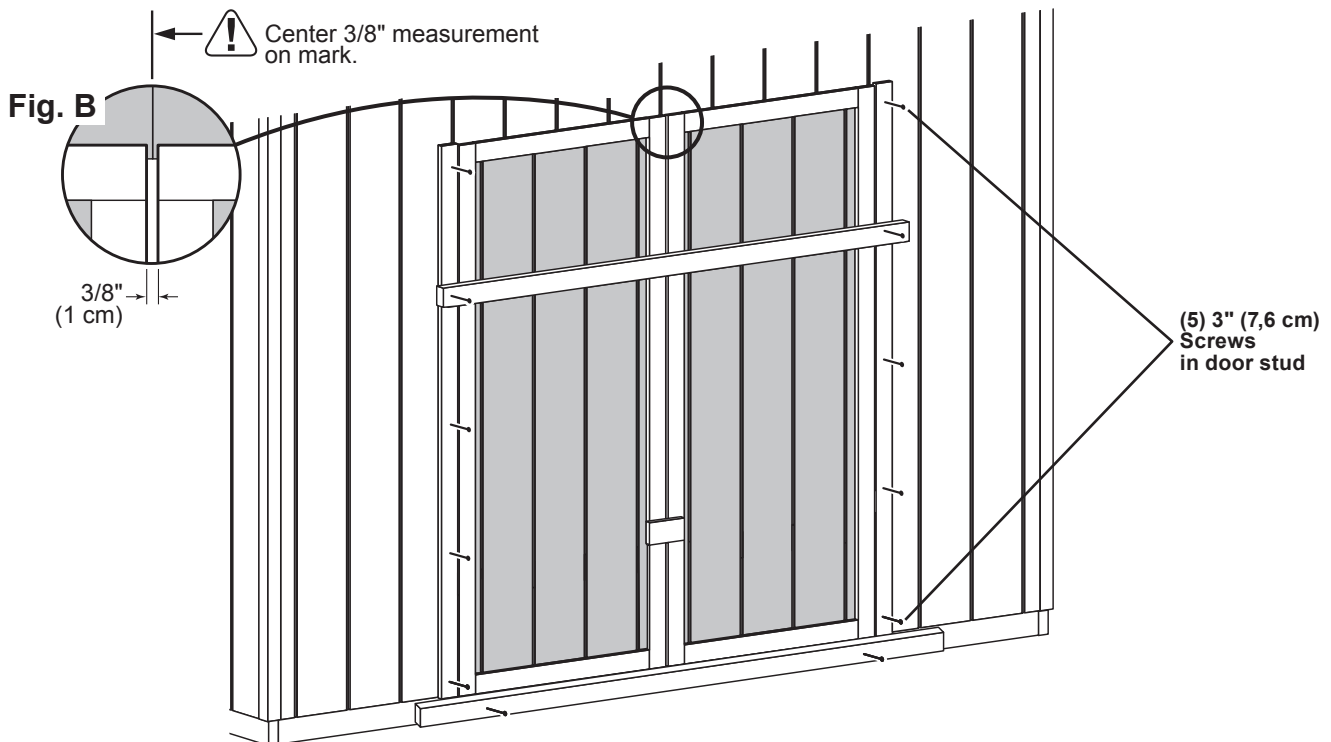

Remove temporary supports and check to make sure doors open and close properly.



Your doors are now installed.

DOORS

PARTS REQUIRED:

x2 **AH**
19/32" x 2-1/2" x 26 5/8" (1,5 x 6,3 x 67,6 cm)

x2 **MDR**
19/32" x 2-1/2" x 39-7/8" (1,5 x 6,3 x 101,3 cm)

x2 **MDL**
19/32" x 2-1/2" x 39-7/8" (1,5 x 6,3 x 101,3 cm)

x1 **ZJ**
19/32" x 2-1/2" x 72" (1,5 x 7,6 x 182,9 cm)

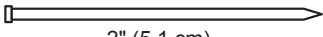
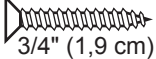
x7  x62 
2" (5,1 cm) 3/4" (1,9 cm)

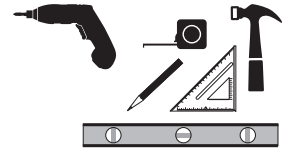

BEGIN You have 3 options for door trim, see Fig. C.

- 1 Arrange trim **AH**, **MDL** and **MDR** as shown. Square **AH** before fastening. Fasten trim to each door from inside with 3/4" screws (Fig. A, Fig B).
- 2 Center trim **ZJ** over doors and secure with (7) 2" finishing nails into framing, as shown.

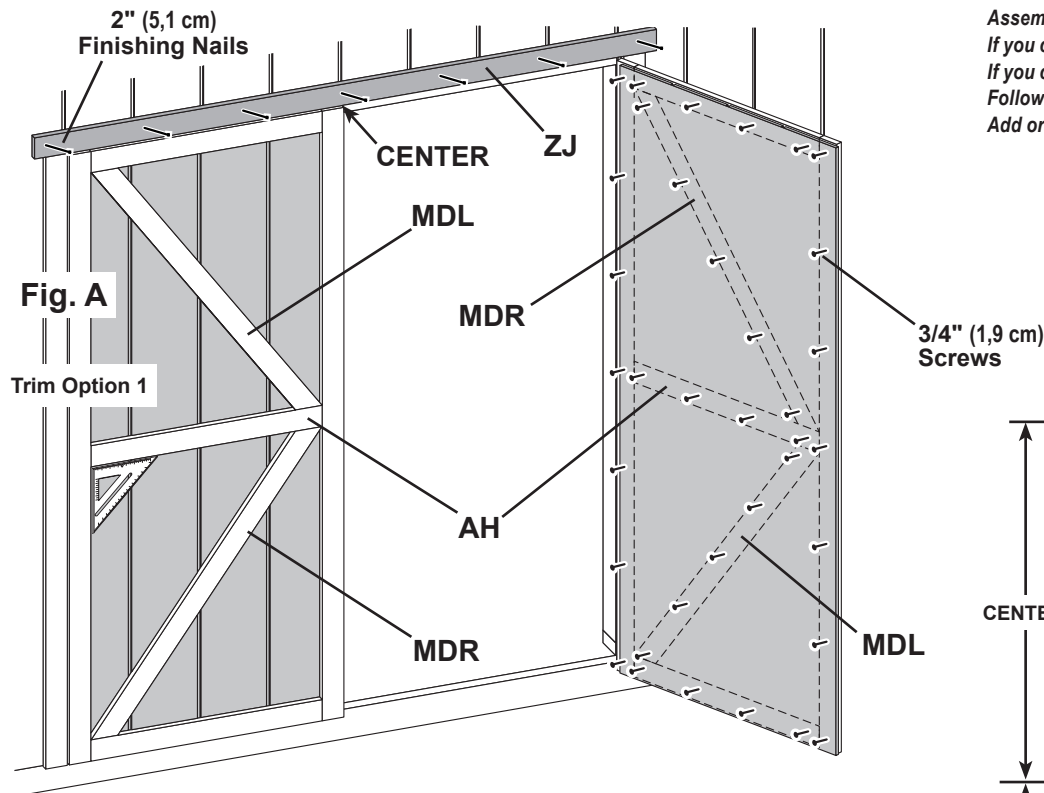
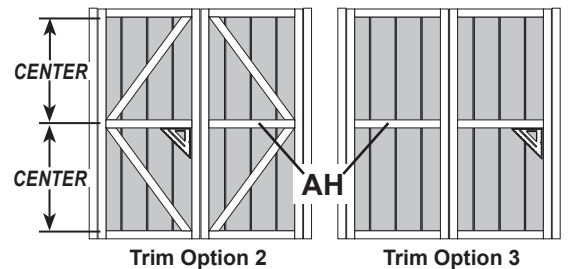

Fig. A

Trim Option 1

Fig. C



Customize your door trim; use 1 of 3 options: Assembly for Option 1 is shown in Fig. A. If you choose Option 2, reverse MDL and MDR. If you choose Option 3, center AH horizontally. Follow steps 1 and 2. Add or subtract more screws as needed.

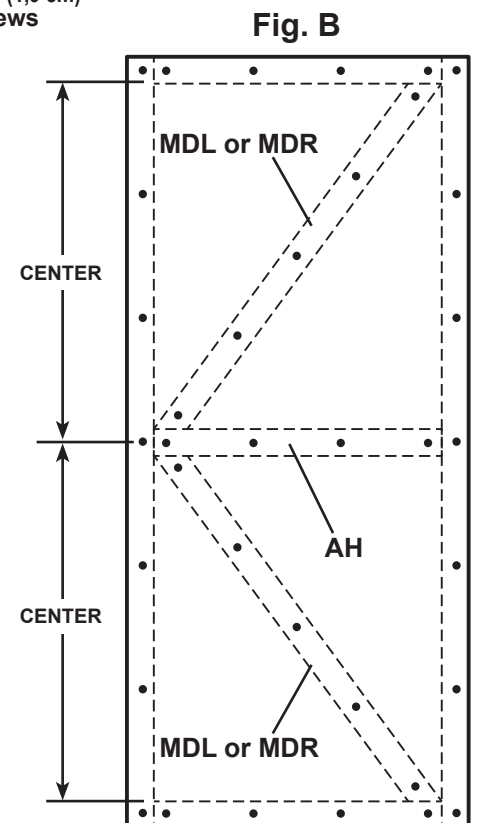

Fig. B



Your door trim is now installed.

DOOR STIFFENERS

PARTS REQUIRED:

x2 **OO**
69" (175,3 cm) Door Stiffener

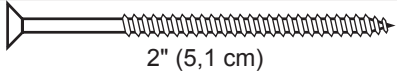
x14 
2" (5,1 cm)



✓ BEGIN

- 1 Center **OO** vertically on the left door in the doorway (**Fig. A**) overlapping 1" (2,5 cm) along the edge of door (**Fig. B**).
Secure with (7) 2" screws through outside trim into **OO**.
- 2 Center **OO** vertically on the right door in the door opening offset 1" (2,5 cm) from the edge of door (**Fig. B**).
Secure with (7) 2" screws through outside trim into **OO**.

Fig. A

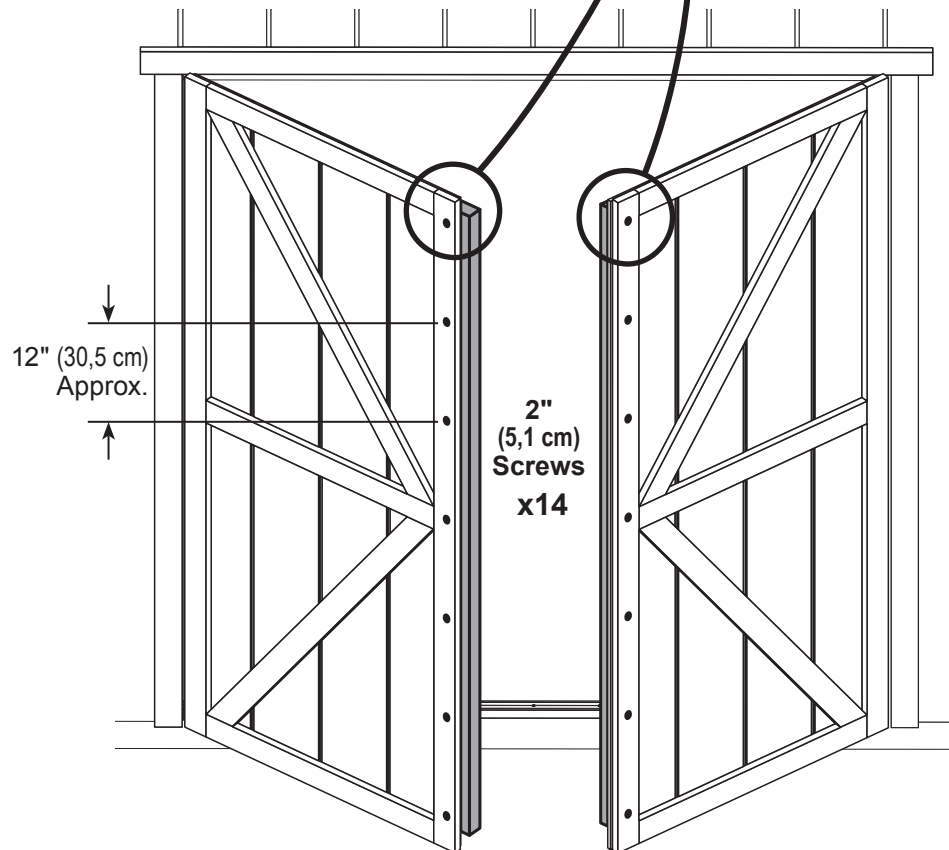
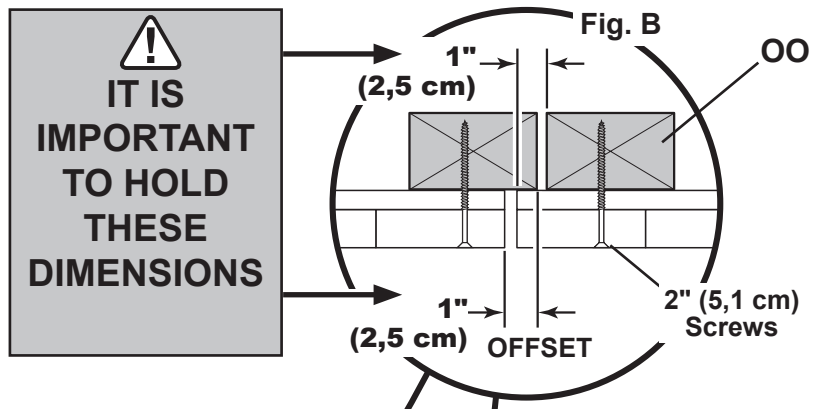
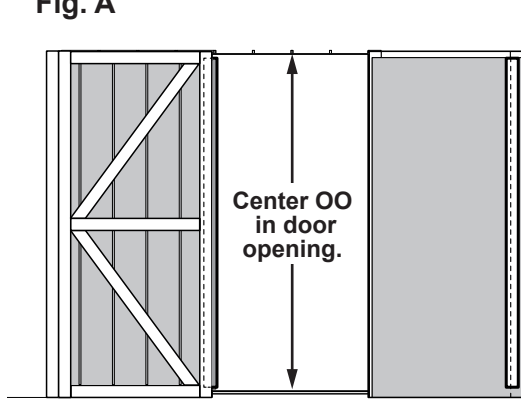

Your door stiffeners are now installed.

DOOR HARDWARE

PARTS REQUIRED:

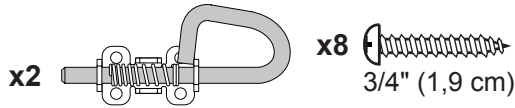

✓ BEGIN

- 1 Place bolt on **OO** in open position with bolt end 3/8" (9,5 mm) down from frame. Bolt is open when loop is contacting base (**Fig A**).
- 2 Mark and pre-drill holes for screws. Install bolt with screws supplied.
Drill 5/16" (7,9 mm) hole deep enough for bolt to slide into.
- 3 Place bolt on **OO** in open position with bolt end 1/2" (12,7 mm) up from floor. Bolt is open when loop is connecting base (**Fig. B**).
- 4 Mark and pre-drill holes for screws. Install bolt with screws supplied.
Drill 5/16" (7,9 mm) hole deep enough for bolt to slide into.

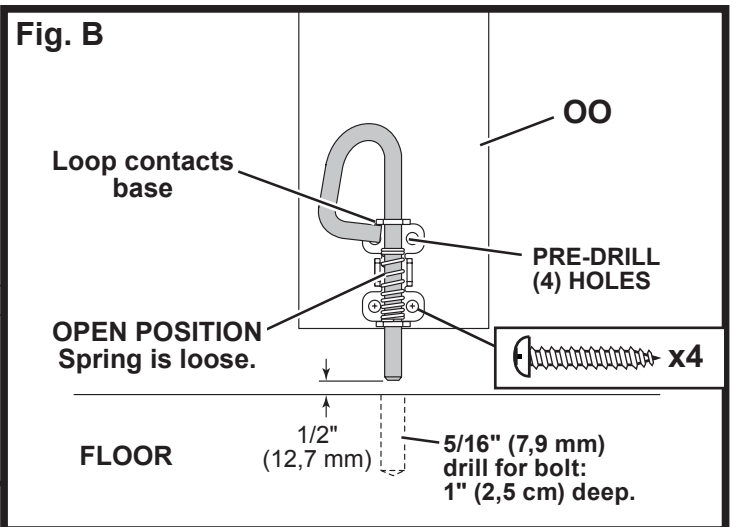
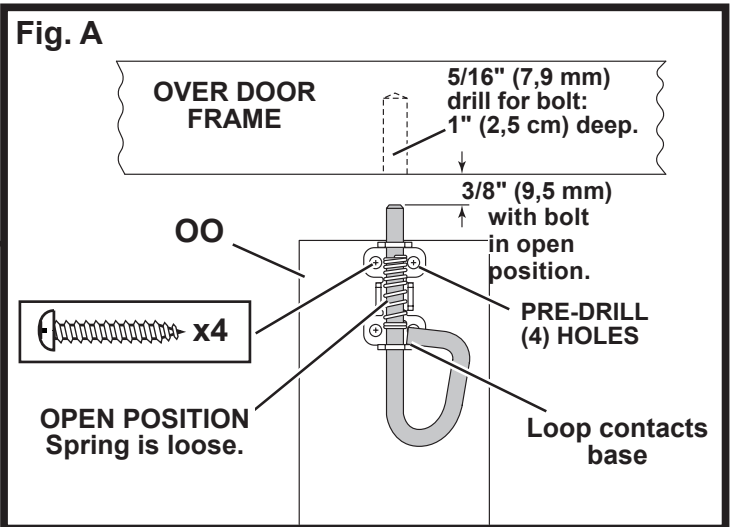
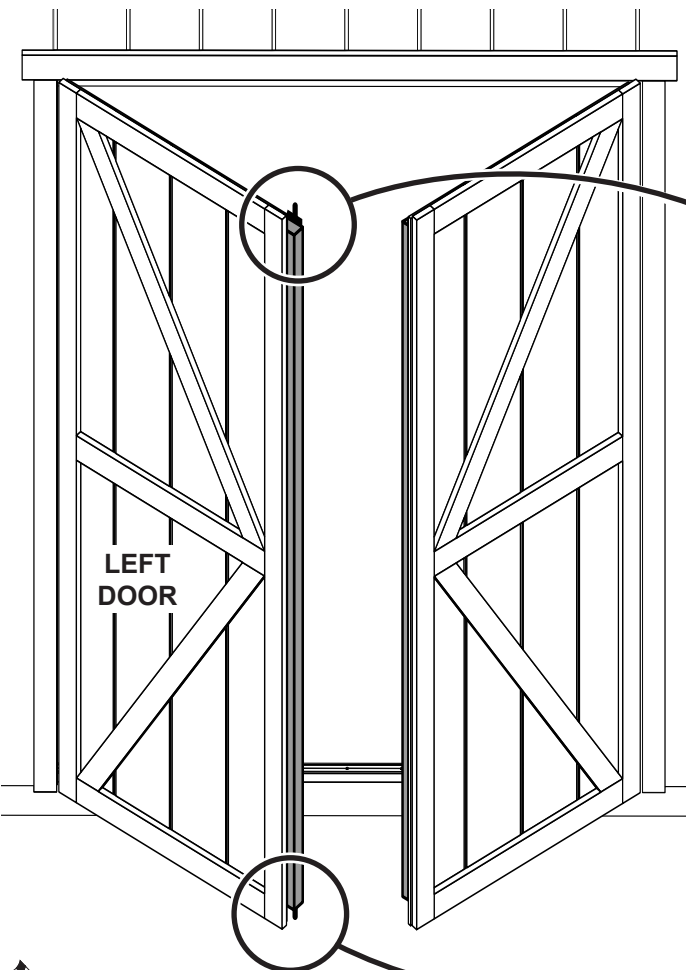

Your spring bolts are now installed.

DOOR HARDWARE

PARTS REQUIRED:

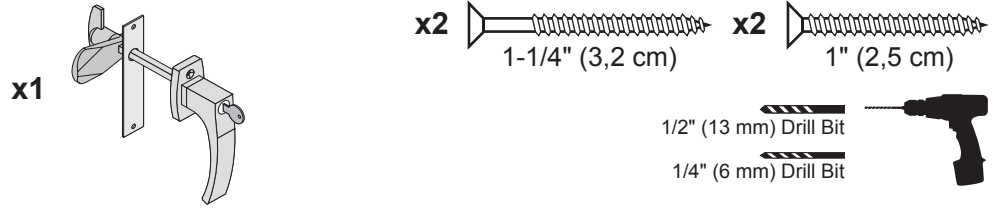

✓ BEGIN

- 1 Measure and mark location of hole on outside of right door as shown (Fig. A).
Pre-drill hole with 1/4" drill.

Re-drill hole with 1/2" drill.



Keep drilled hole square to trim to avoid breaking edge of door stiffener.

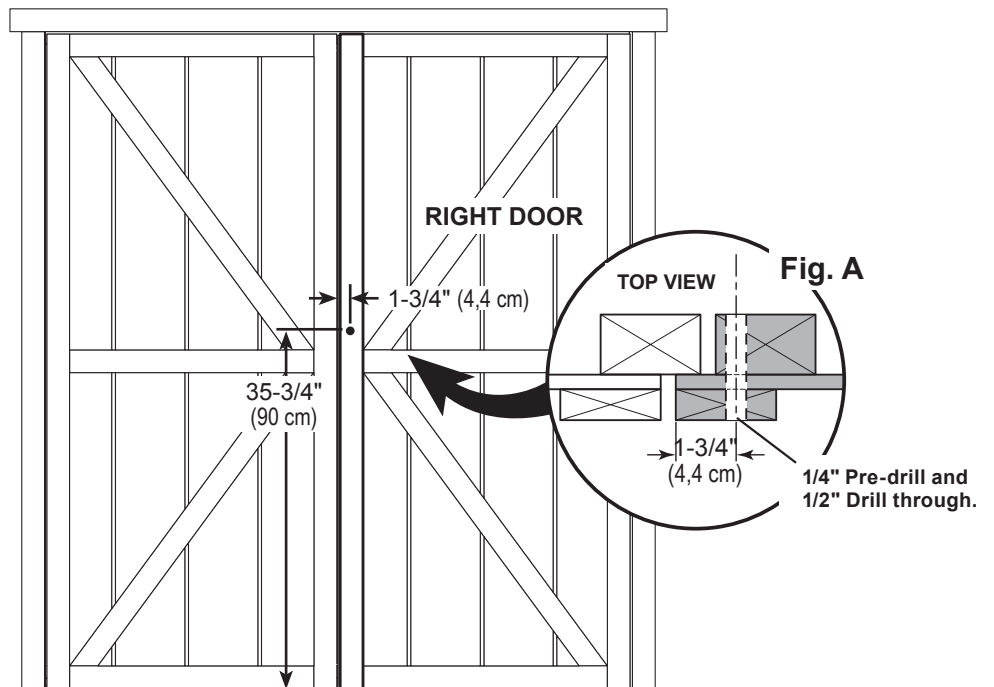

- 2 Secure backplate with 1" screws and handle with 1-1/4" screws as shown.

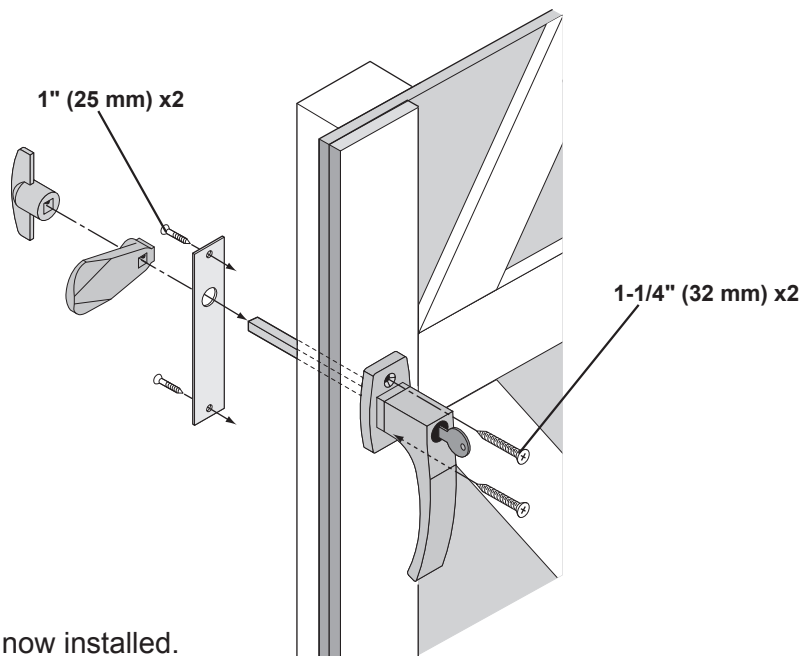

Your door handle is now installed.

HOOK & EYE

PARTS REQUIRED:

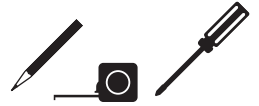

✓ **BEGIN**

- 1** Install hooks in wall and into framing behind (Fig.A).
- 2** Swing door open to locate eye.

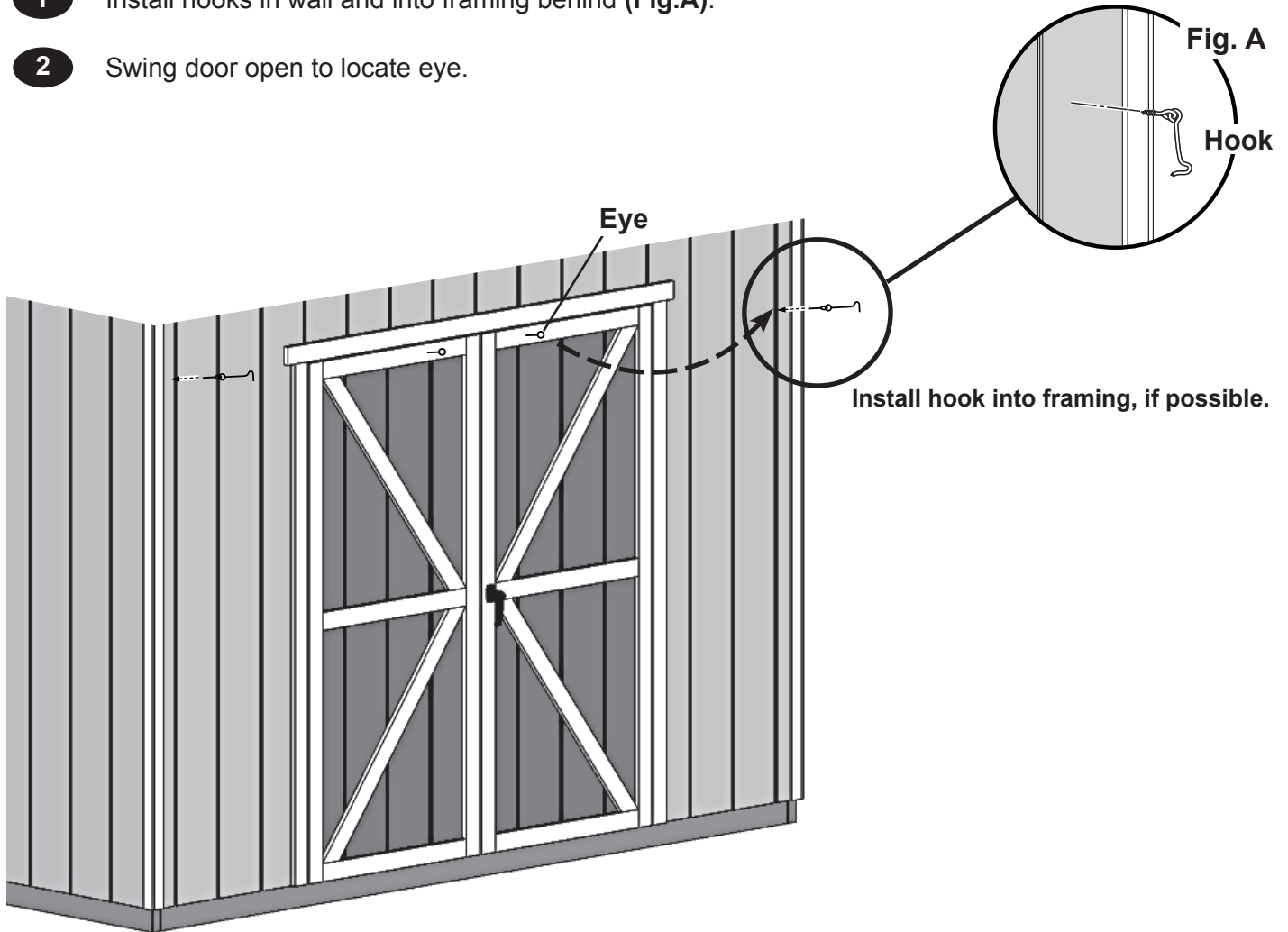

✓ **FINISH**

You have installed your hook & eyes.

VENT (Not included in kit.)

• Follow directions provided by manufacturer and these instructions.

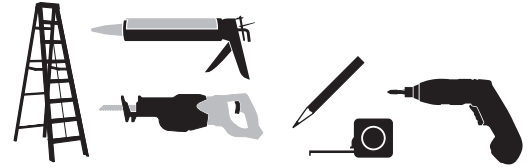
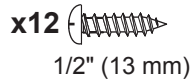
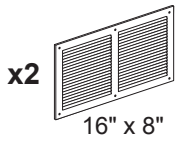

✓ **BEGIN**

- 1 Locate and mark for two vents in side walls as shown; (1) at top and (1) at bottom.

Cut out marked openings.

Caulk behind vent flanges.

Secure with 1/2" screws.

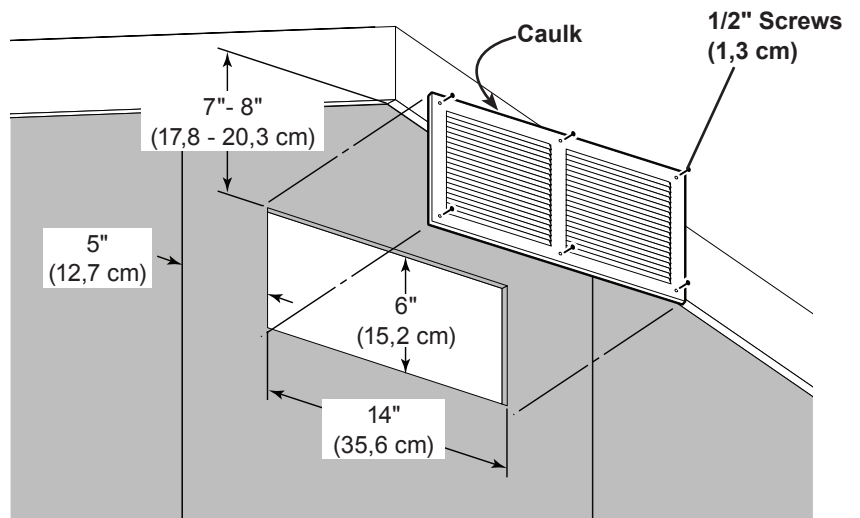
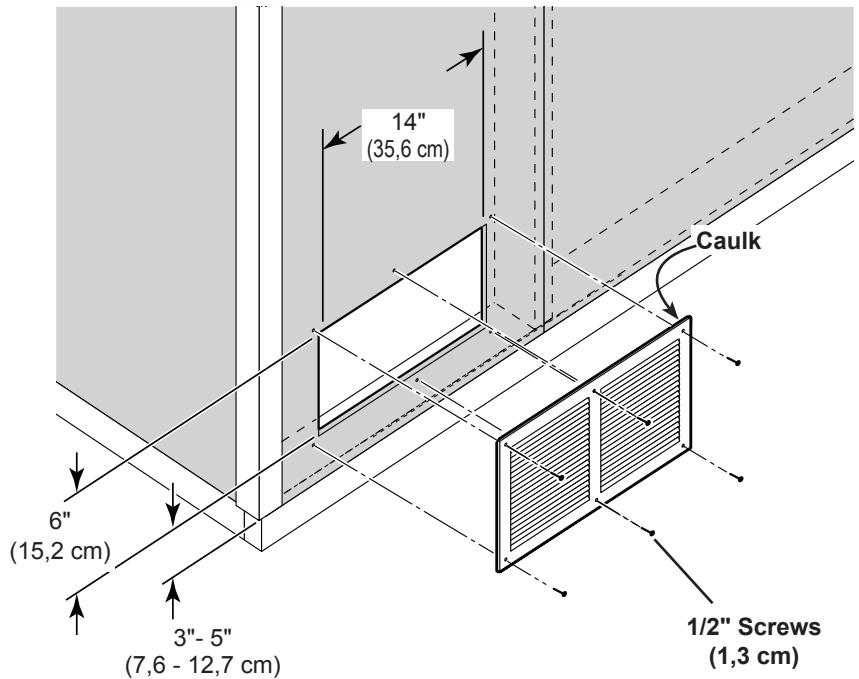

FINISH

Your vents are now installed.

PAINT & CAULK

- NOT INCLUDED -



- Use acrylic latex caulk that is paintable. Caulk at all horizontal and vertical seams, between the trim and walls, and all around the door trim.
- Use a high quality exterior acrylic latex paint. When painting your building, there are a few key areas that can be easily overlooked that must be painted:
 - Bottom edge of all siding and trim
 - Inside of doors and all 4 edges

Note:

Prime all un-primed exterior wood before painting.
(Follow directions provided by manufacturer.)

ROOF FELT

- NOT INCLUDED -

- Install felt flush to all roof edges overlapping 3". Use minimal amount of roofing nails to hold in place.

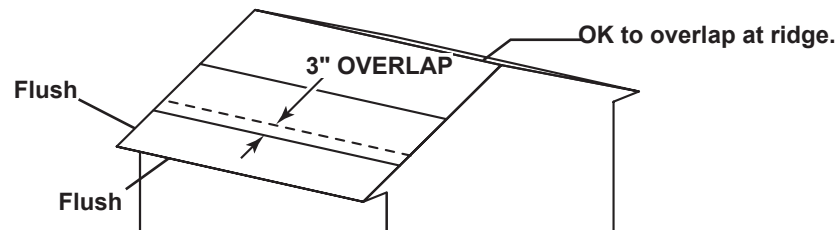

DRIP EDGE

- NOT INCLUDED -

- Install drip edge over roof felt on gable side and under roof felt on eave side (Fig. A).
- Do not use nails on side of drip edge that hangs over side of building.
- Only nail top of drip edge as shown.

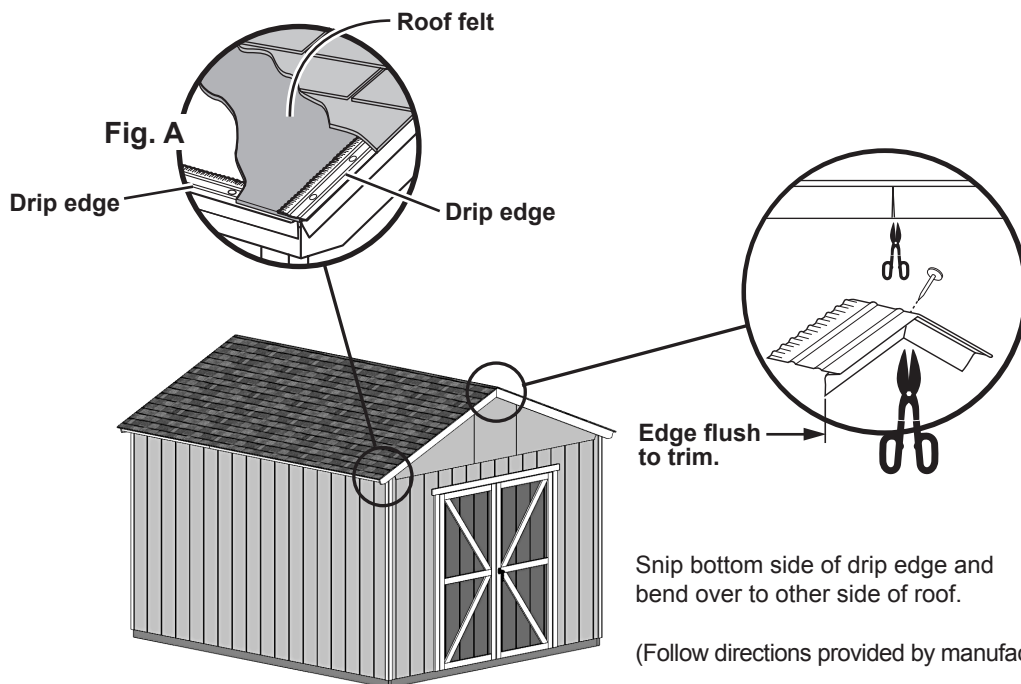

NOTE: 10' x 12' Model Shown.

SHINGLES

- NOT INCLUDED -

- Follow directions provided by manufacturer and these instructions.

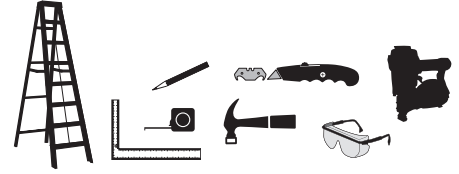

! Familiarize yourself with a 3-Tab Shingle.

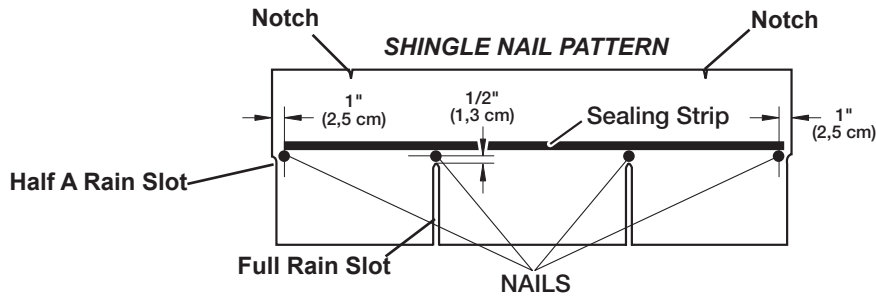

! NEVER DRIVE FASTENERS INTO OR ABOVE SEALING STRIPS.

✓ BEGIN

- 1 Install first starter row upside down and color up with a 1" overhang at back and bottom of roof panel. Use (4) nails per shingle. Starter row must be straight and level all the way across with lower edge of roof deck.
NOTE: If you have installed drip edge install shingles flush to drip edge.

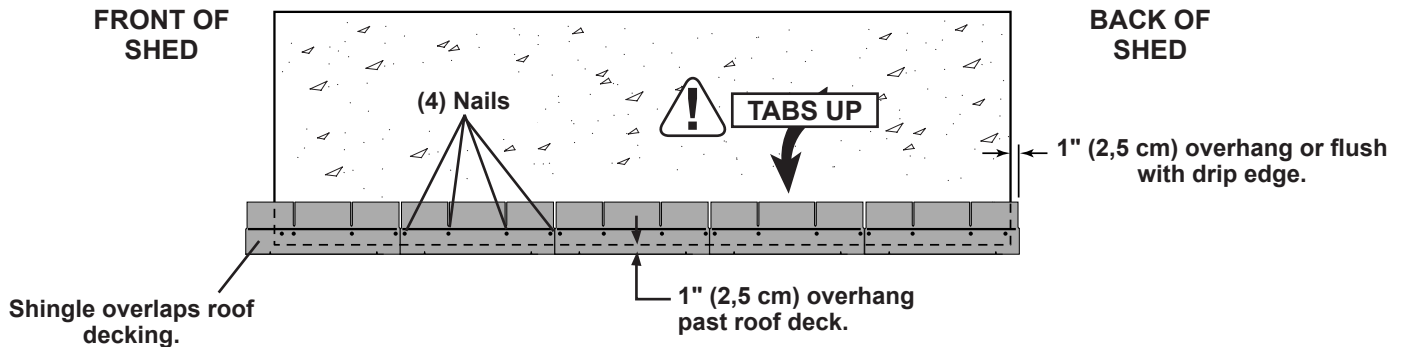

SHINGLES

continued...

- 2 Beginning at front of shed, install first row of shingles with notch at 1" past roof edge or flush with drip edge.

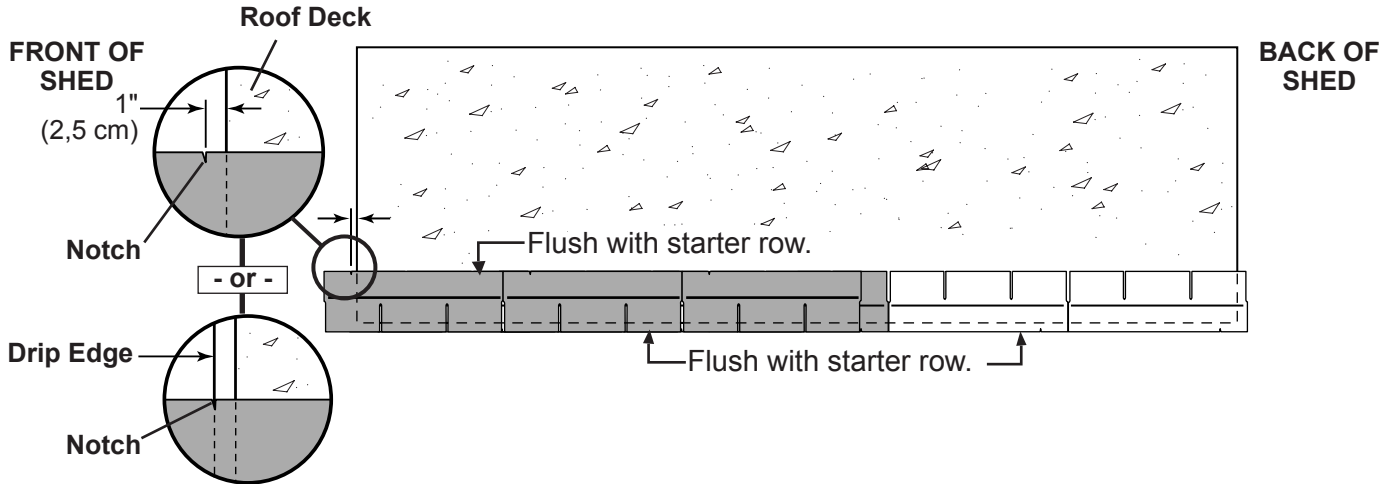

- 3 Install second row of shingles flush at top of first row's rain slots. Ensure 1" overhang or flush to drip edge at front, stagger each row.

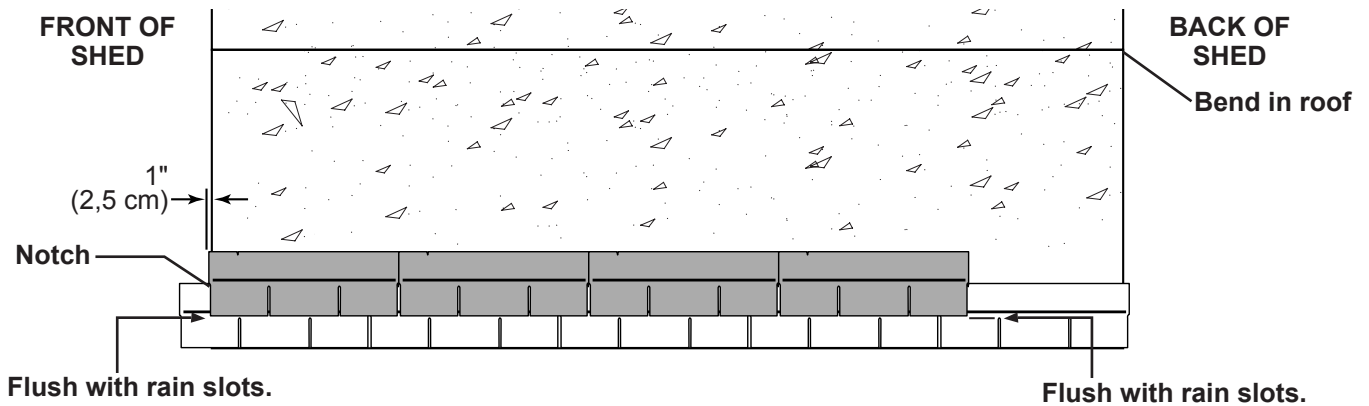

- 4 Continue installing rows of shingles by staggering at front.

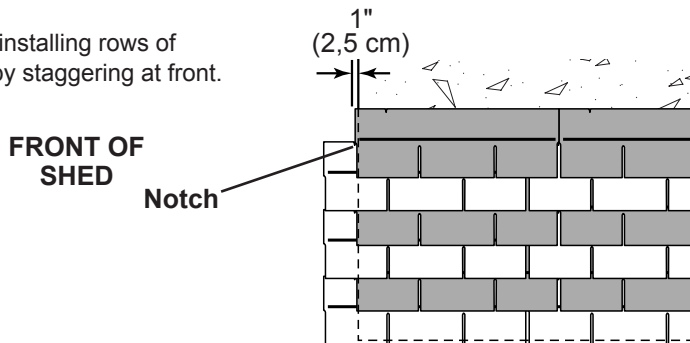

SHINGLES

continued...

- 5 Continue installing rows of shingles to the peak. At the peak make sure there is a maximum of 5" or less to the rain slot, as shown below. If shingles overlap at ridge cut to peak with a utility knife.

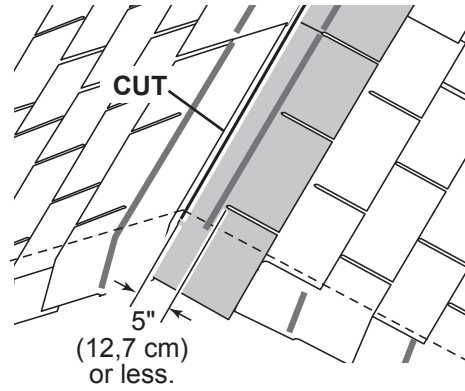
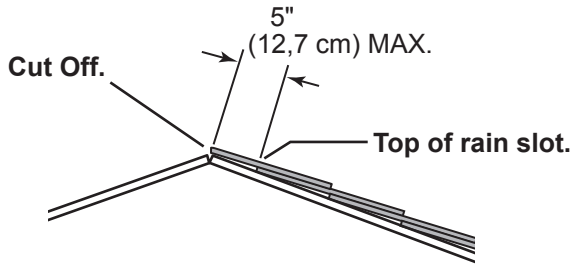

- ! • If more than 5" to rain slot you must install another row of shingles.

- 6 Repeat steps 1 - 7 to shingle the opposite side of your roof. Trim shingles at ridge.

- 7 Once both sides are shingled you need to trim ends. Strike a chalk line 1" from edge.

- 8 Using your shingle hooked blade carefully cut shingles along chalk line.

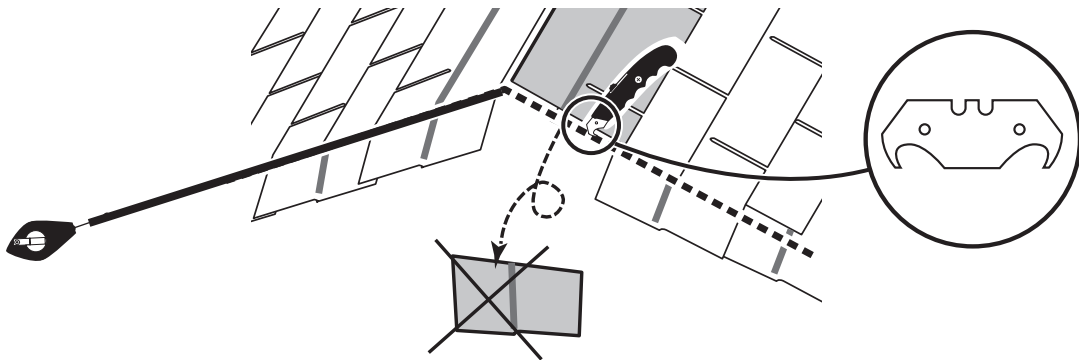

You have finished shingling your roof. Proceed to capping the ridge.

SHINGLES - RIDGE CAP

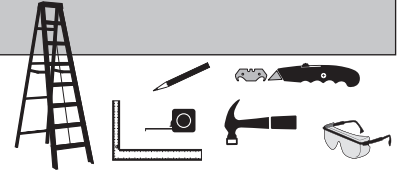

• You will finish off the top of the roof with a ridge cap made from shingles.

✓ BEGIN

1 Cut shingles in THREE pieces. Hint: Use cut-off pieces first.

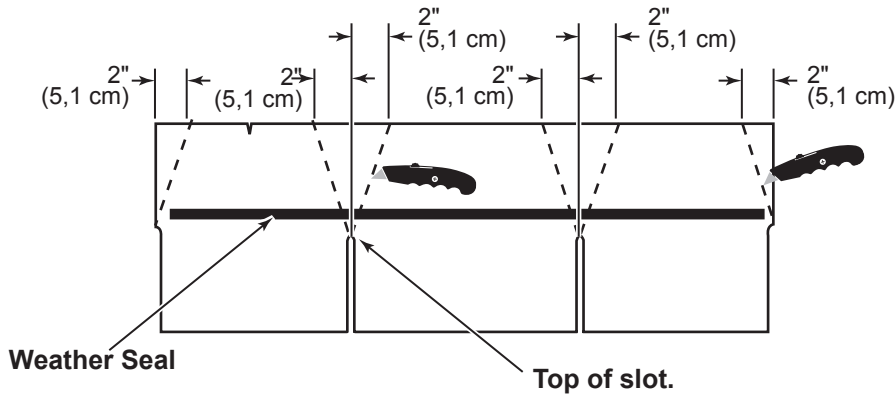

 Score shingle, then snap-off angled cut.

10x12'

10x16'



30 to 32 Pieces

40 to 42 Pieces

Note: • You will need about 30 - 32 cut pieces for 10' x 8' model
• You will need about 38 - 40 cut pieces for 10' x 12' model

2 Install first ridge cap flush to shingles at front, as shown.

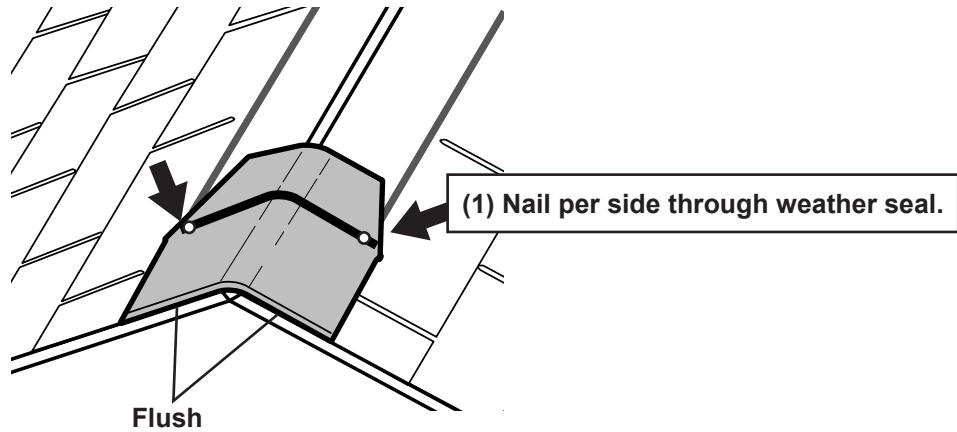

3 Install second ridge cap 5" back, as shown.

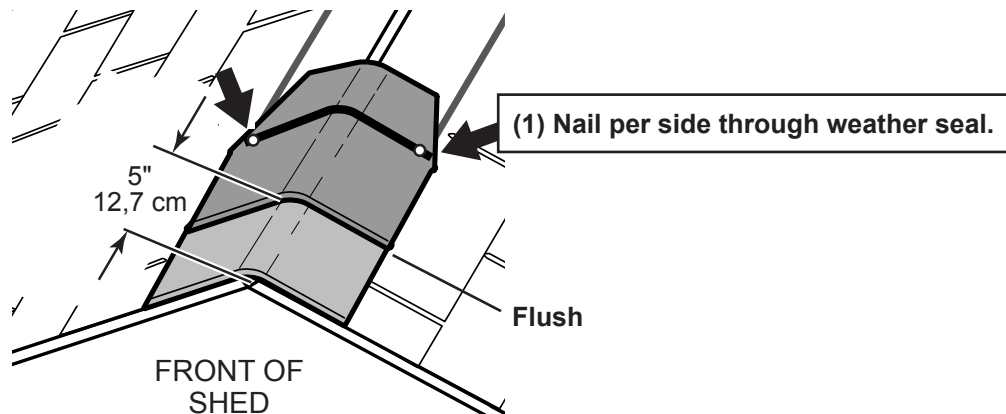

SHINGLES - RIDGE CAP

continued...

4 Continue installing ridge cap to back of roof.

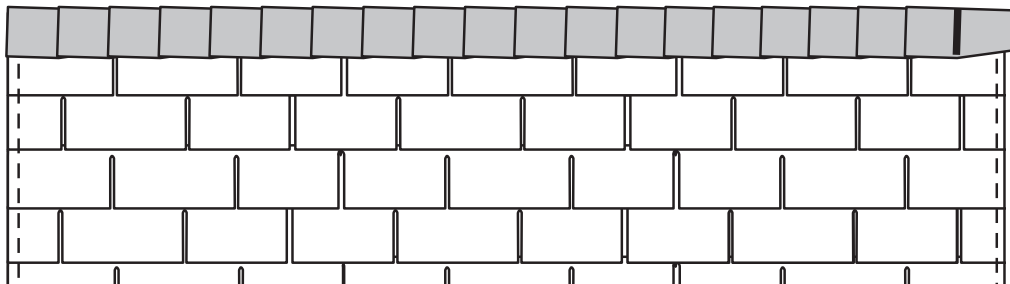

5 Make sure there is 4" between the shingle-color and edge of shingles.

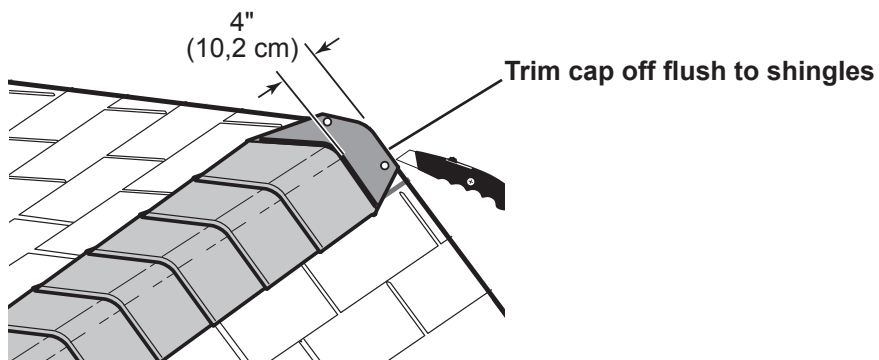

6 When you have 4" minimum of shingle color cut one piece to cap your roof.

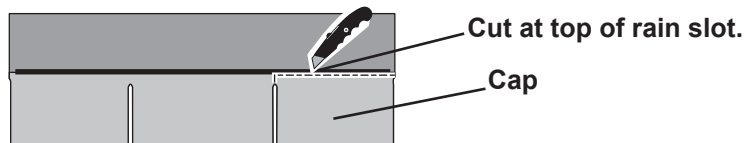

7 Install flush to shingles.

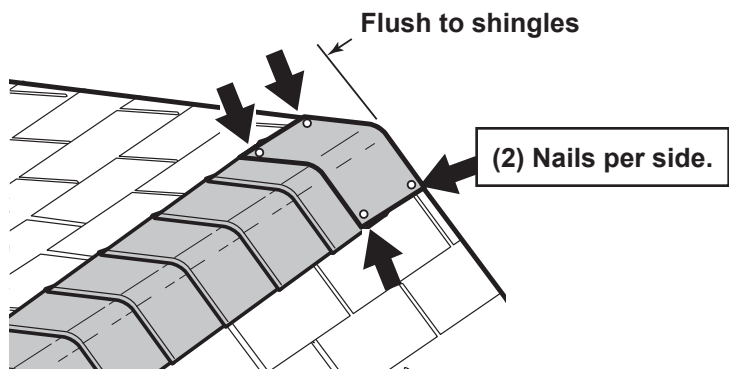

You have finished your ridge cap.

16558 10' x 12' Order Form

CATEGORY	PART DESCRIPTION	PART SIZE	PART ITEM #	BUILDING QTY.	PART ID
2 X 4	Collar Ties	*LUM SPF 2X4X72 #2&BTR	O 7200000000	2	TM
	Back Wall Top & Btm "A" / Dblr "A"	LUM SPF 2X4X96 #2&BTR	12306	4	TP
	Side Wall T & B Plate "A" / Dblr "B"	LUM SPF 2X4X92-5/8 #2&BTR	12305	4	TJ
	Side Wall T & B Plate "B"	2 X 4 X 44 3/8" PLATE	O 4406000000	2	HVC
	Side Wall Top Plate	2 X 4 X 68-1/2"	O 6808000000	4	YFA
	Doubler "C"	2X4X48" DOUBLER/ PLATE/ CRATE	O 4800000000	2	SP
	Doubler "D"	2 X 4 X 20 3/8" DOUBLER	O 2006000000	2	JBD
	Back Wall T & B Plate "B"	2 X 4 X 24" DOUBLER / PLATE	O 2400000000	2	RL
	Front Wall Plate "A"	LUM SPF 2X4X84 #2&BTR	12307	2	TO
	Front Wall Plate "B"	2 X 4 X 36"	O 3600000000	2	SL
	Wall Studs	2 X 4 X 78 1/2"	O 7808000000	22	AI
	Jack Studs	2 X 4 X 68" STUD	O 6800000000	2	UM
	Over Door Crippler	2 X 4 X 7"	O 0700000000	5	AL
	Header	2 X 4 X 67"	O 6700000000	2	AM
	Rafter	2 X 4 X 65" 22.5" RAFTER	O 65002222000	14	AD
Front / Rear Gable Connector	2 X 4 X 18 1/8"-22.5" CONNECT	O 18022222000	4	AF	
2 X 6	Overhang "A"	LUM WSPF 2X6X96 #1 PREMIUM PET	12416	2	VX
	Overhang "B"	2 X 6 X 49 3/4" OVERHANG	N 49120000000	2	WTC
1 X 3 PINE	Gauge Block	1 X 3 X 5" PINE FILLER	U 05000000000	1	GAA
7/16 OSB	Upper Roof Panel "A"	OSB 7/16" x 4' x 8'	11110	2	---
	Upper Roof Panel "B"	7/16" OSB 47 7/8" X 48" ROOF	C 48004714000	2	---
	Lower Roof Panel "A"	7/16" OSB 23 1/2" X 96" ROOF P	C 96002308000	2	---
	Lower Roof Panel "B"	7/16" OSB 23 1/2" X 48" FILLER	C 48002308000	2	---
	Door Header Filler	7/16" OSB 3 1/4" X 66 3/4" HEADER	C 66120304000	1	---
GUSSETS	Gusset	EZ8"/OSB 6" X 24" GUSSET 22.5"	J 24000600225	12	---
NO GROOVE SIDING	Center Gable Panel	3/8" NG 23 7/8" X 23 9/16"	K 23092314000	2	---
	Front / Rear Gable Panel - Right	3/8" NG 23 9/16" X 48" RIGHT FRONT GABLE	K 48002309100	2	---
	Front / Rear Gable Panel - Left	3/8" NG 23 9/16" X 48" LEFT FRONT GABLE	K 48002309200	2	---
	Corner Trim	3/8" NG 1 3/4" X 83-1/2"	K 83080112000	8	---
80C SIDING	Rearwall Panel "A" / Side Panel	SIDING 8" OC 4'X7'	11506	7	---
	Rear Panel "B"	EZ 8" 23 7/8" X 84" WALL PANEL	J 84002314000	3	---
	Frontwall Panel "A"	EZ 8" 11 7/8" X 84" PANEL	J 840011140WG	1	---
	Frontwall Panel "B"	EZ 8" 11 7/8" X 84" PANEL	J 84001114NOG	1	---
	Frontwall Panel Right	EZ 8" 48" x 84" RIGHT FRONTWALL	J 84004800101	1	---
Frontwall Panel Left	EZ 8" 48" x 84" LEFT FRONTWALL	J 84004800201	1	---	
19/32 X 3 SMART TRIM	Vertical / Over Door Trim	19/32 TST 2 1/2" X 72" TRIM	UT72000208000	1	ZJ
	Long Cross Buck - Right	19/32 TST 2 1/2" X 39-7/8" 36.5" L/S RGT X-BUCK	UT39143737100	2	MDR
	Long Cross Buck - Left	19/32 TST 2 1/2" X 39-7/8" 36.5" L/S LFT X-BUCK	UT39143737200	2	MDL
	Horizontal Door Rail	19/32 TST 2 1/2" X 26 5/8"	UT26100208000	2	AH
19/32 X 4 SMART TRIM	Gable Trim Right	19/32 TST 3 1/2" X 71 15/16" 22.5" O/E RGT TRIM	UT71150308221	2	AUR
	Gable Trim Left	19/32 TST 3 1/2" X 71 15/16" 22.5" O/E LFT TRIM	UT71150308222	2	AUL
PURCHASED COMPONENTS	Door Stiffener	LSL 1-1/4 X 2-1/4 X 69 PET	12715	2	OO
	Chrome Single Point Locking Handle	DOOR HANDLE LOCKING SINGLE PT.	15210	1	---
	Hardware Kit	H/K HHP SERIES GABLES	15773	1	---
PACKAGING	Instructions		16558	1	---
Right Door Assembly	30222-R				
	Door Panel	EZ 8" 31 1/4" X 71 1/2"	J 71083104000	1	---
	Right Hinge Assembly	HINGE RIGHT (RED) 19/32x3 THIN TRIM	30121-TT	1	---
	Vertical Door Stiles	19/32 TST 2 1/2" X 71 5/8"	UT71100208000	2	GY
	Horizontal Door Rails	19/32 TST 2 1/2" X 26 5/8"	UT26100208000	2	AH
Left Door Assembly	30222-L				
	Door Panel	EZ 8" 31 1/4" X 71 1/2"	J 71083104000	1	---
	Left Hinge Assembly	HINGE LEFT (GREEN) 19/32x3 THIN TRIM	30131-TT	1	---
	Vertical Door Stiles	19/32 TST 2 1/2" X 71 5/8"	UT71100208000	2	GY
	Horizontal Door Rails	19/32 TST 2 1/2" X 26 5/8"	UT26100208000	2	AH

LIMITED CONDITIONAL WARRANTY*

Backyard Storage Solutions, LLC warrants the following:

1. Every product is warranted from defects in workmanship and manufacturing for 1 year.
2. All accessories, hardware and metal components are warranted for 2 years.
3. All Oriented Strand Board (OSB) is warranted for 2 years
4. Siding and Trim is warranted for 15 years.
5. LP Prostruct® Flooring is warranted for 10 years
6. Cedar lumber is warranted for 15 years.
7. Preserved Pine is warranted for 10 years.
8. Redwood is warranted for 10 years.
9. Metal Roof is warranted for 25 years.

Backyard Storage Solutions, LLC will repair, replace or pay for the affected part. In no event shall Backyard Storage Solutions, LLC pay the cost of labor or installation or any other costs related thereto. All warranties are from date of purchase. If a cash refund is paid on an affected part, it will be prorated from the date of purchase.

CONDITIONS

The warranty is effective only when:

1. The unit has been erected in accordance with the assembly instructions.
2. The unit has been properly shingled and painted or stained and regularly maintained thereafter.
3. The failure occurs when the unit is owned by the original purchaser.
4. Backyard Storage Solutions, LLC has received the warranty registration card within thirty (30) days of purchase and notification of the failure in writing within the warranty period specified above.
5. Backyard Storage Solutions, LLC has had reasonable opportunity during the sixty (60) days following receipt of notification to inspect and verify the failure prior to commencement of any repair work.

REQUIREMENTS

Storage Buildings

To validate your warranty, it is necessary to properly maintain your Backyard Storage Solutions, LLC unit; shingle the roof and paint or solid-colored stain the siding using quality, 100% acrylic latex exterior product with a minimum of two (2) coats within thirty (30) days of assembly; caulk above all doors and all horizontal and vertical trim boards; paint and seal all exposed edges, sides and faces of siding/trim and OSB siding to include all exterior walls and all sides and all edges of doors.

Gazebos & Pergolas

To validate your warranty, it is necessary to properly maintain your Backyard Storage Solutions, LLC unit. This includes treating all of the exposed cedar and pine surfaces on your gazebo or pergola structure with an exterior grade wood preservative, an exterior oil-based semi-transparent stain, an acrylic latex exterior paint or an acrylic latex solid color exterior stain within 30 days of assembly and as needed thereafter to maintain your warranty.

Keep vegetation trimmed away from building and make sure siding panels and trim do not come in contact with masonry or cement. The minimum ground clearance for siding must be one half inch (½ inch) from concrete slab or two and one half inches (2 ½") from the ground when building is erected or constructed on a treated wood floor kit. Water from sprinklers must be kept off unit. In no event will Backyard Storage Solutions, LLC be responsible for any indirect, incidental, consequential or special damages nor for failure(s) that are caused by events, acts or omissions beyond our control including, but not limited to, misuse or improper assembly, improper maintenance (which eventually leads to rot or decay) and acts of God. Backyard Storage Solutions, LLC will not be held responsible for any labor costs incurred to construct your unit.

This warranty gives you certain specific rights that vary from state to state.

CLAIM PROCEDURE

To make a claim under this warranty, you can either call 1-888-827-9056 or email: customerservice@backyardproducts.com.

Please have ready the information below when you call or include the information in your email:

1. The model and size of the product.
2. A list of the part(s) for which the claim is made.
3. Proof of purchase of the Backyard Storage Solutions, LLC item, as shown on the original invoice or receipt.
4. Run code: found on exterior product label or assembly instructions enclosed in the product package.

All other inquiries can be mailed to:

Backyard Storage Solutions, LLC
Attn: Customer Service
1000 Ternes
Monroe, MI 48162

***WARRANTY TERMS MAY VARY OUTSIDE THE U.S.A.**

IMPORTANT: This is your warranty certificate.

15Y PSS BB GEN LDR: 3/20/2019