

boahaus

ASSEMBLY INSTRUCTIONS INSTRUCCIONES PARA ARMADO

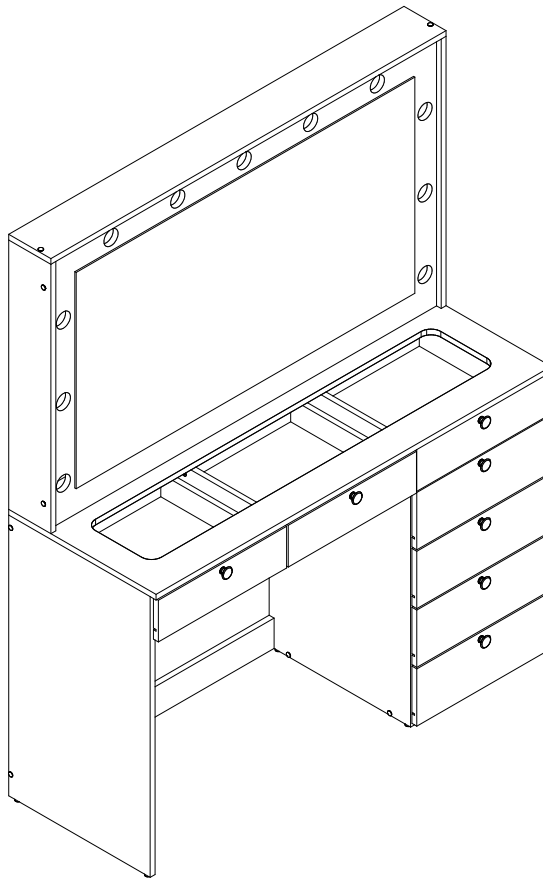

ATTENTION!!!

Any inquiry or replacement parts
you need, contact us directly at:
contact@boahaus.com

Scan this QR Code to contact to
Customer Support Team

Or Call Us at +1 281-809-4043

boahaus

You can see the ASSEMBLY VIDEO scanning this QR code.

Or enter the following link:

DRESSING TABLE WITH MIRROR TOCADOR CON ESPEJO

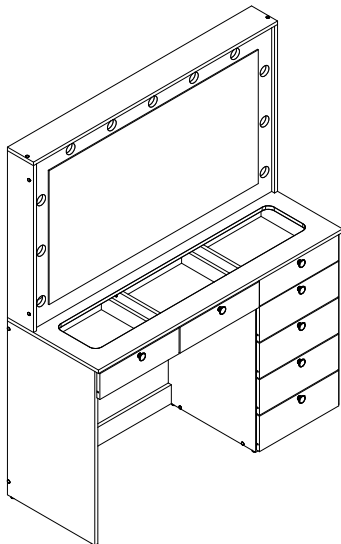

Approx. product weight 105.02 lbs. / 47.71Kg. *
*Weight may vary +/- 5%.

Lot: See package

Product date: See package

Purchase date: _____

**THIS INFORMATION BOOKLET CONTAINS IMPORTANT SAFETY INFORMATION.
PLEASE READ AND KEEP FOR FUTURE REFERENCE.
ESTE FOLLETO CONTIENE INFORMACIÓN DE SEGURIDAD IMPORTANTE. POR
FAVOR, LEA Y GUÁRDELO PARA REFERENCIA FUTURA.**

GENERAL SAFETY INFORMATION

INFORMACIÓN GENERAL DE SEGURIDAD



Please read the Assembly Instructions before assembling this product.

Lea las instrucciones de armado antes de ensamblar este producto.

Remove all the hardware from the box and sort by type and check to see that all the hardware and parts are present BEFORE assembling.

Extraiga todo el hardware de la caja y ordene por tipo y verifique que todo el hardware y las piezas están presentes ANTES de ensamblar.

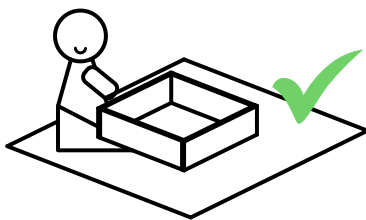
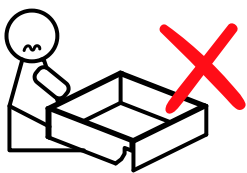
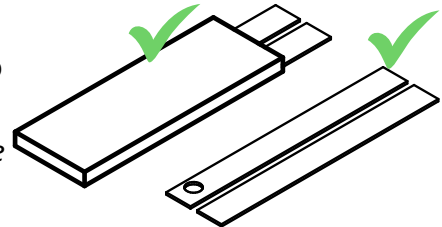

To avoid damage, assemble the product on a sturdy, level, and protective surface.

Para evitar daños, ensamble el producto sobre una superficie resistente, nivelada y con protección.

Please wait until all steps are completed before fully tightening bolts and make sure all bolts are tightly fastened before the unit is used.

Espere hasta que todos los pasos se hayan completado antes de apretar completamente los tornillos y asegúrese de que todos los tornillos y accesorios estén bien apretados antes de usar la unidad

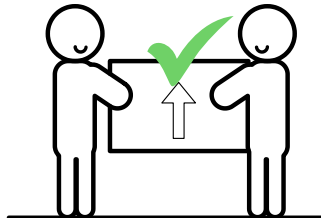
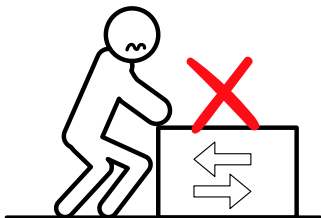
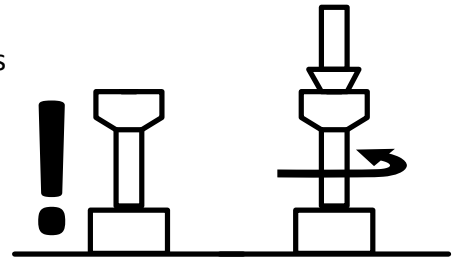

To move the product, you must lift it. DO NOT drag it, if you drag it can cause overturning.

Para mover el producto debe levantarlo. NO lo arrastre, si lo arrastra puede causar volcamiento.

This product is sold with a hardware kit to be fixed on the wall. You must install this kit to prevent any accidents or damages. When properly installed, this restraint can provide protection against the unexpected tipping of the unit due to smaller, bumps or climbing. The restraint is only a deterrent and is not a substitute for proper adult supervision. The use of tip-over restraints may only reduce, but not eliminate, the risk of tip-over.

Este producto se vende con un kit de accesorios para ser fijado en la pared. Debe instalar este kit para evitar accidentes o daños. Cuando se instala correctamente, esta restricción puede proporcionar protección contra la inclinación inesperada de la unidad debido a temblores pequeños, golpes o al treparse. La restricción es solo un elemento disuasivo y no es un sustituto de la supervisión adecuada de un adulto. El uso de restricciones de vuelco solo puede reducir, pero no eliminar, el riesgo de volcarse.

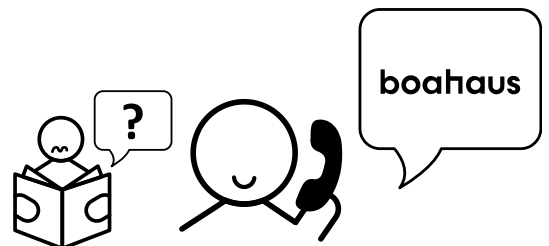
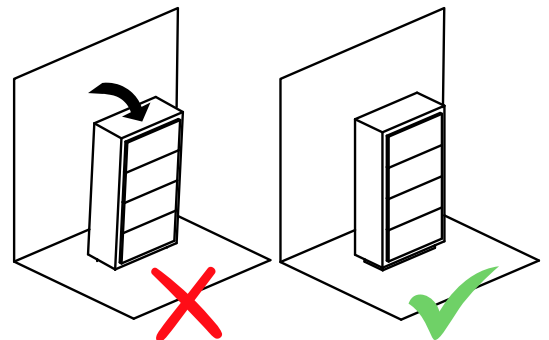

YOU WILL NEED USTED NECESITARÁ

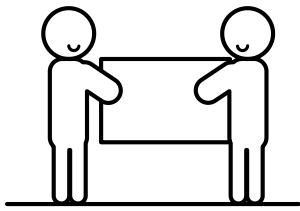

2 people
2 personas

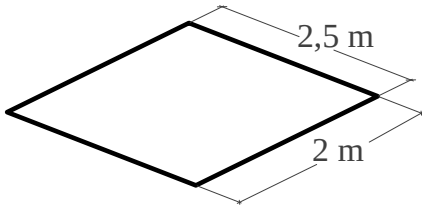

Recommended space
for assemble
*Espacio recomendado
para el armado*

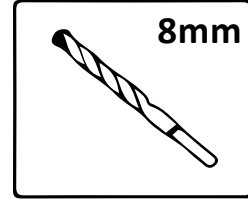
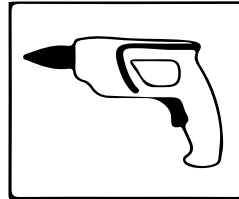
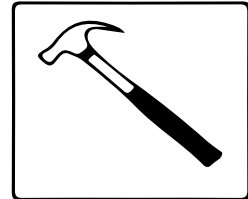
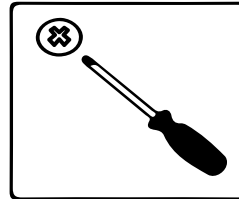

Note: Place a carpet or blanket in the assembly area to avoid damage to the parts during the process.

Nota: Colocar una alfombra o manta en el area de armado para evitar daños en las piezas durante el proceso.

The drill will be used **ONLY** to fix the furniture to the wall.

El taladro será usado **SOLO** para fijar el mueble a la pared.

GENERAL DIMENSIONS DIMENSIONES GENERALES

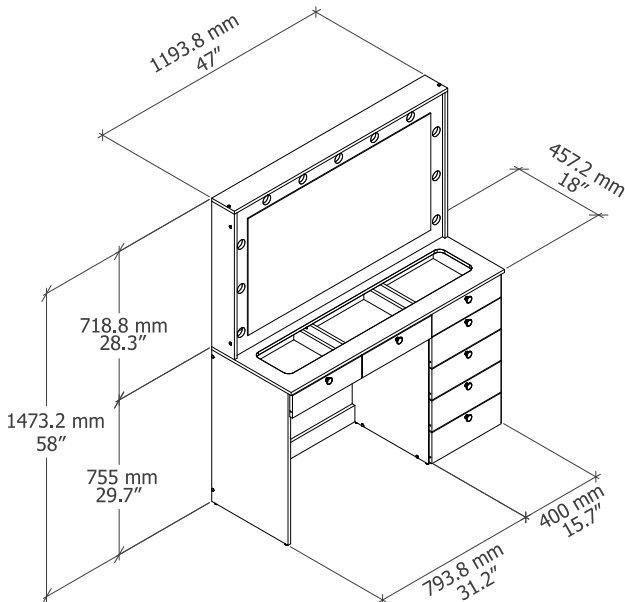

MAXIMUM WEIGHT SUPPORTED PESO MÁXIMO SOPORTADO

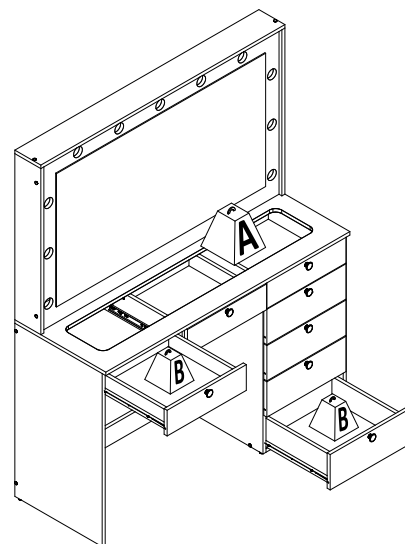

Weight in pounds. / Peso en libras

Note: weight must be evenly distributed.
Nota: el peso debe estar distribuido







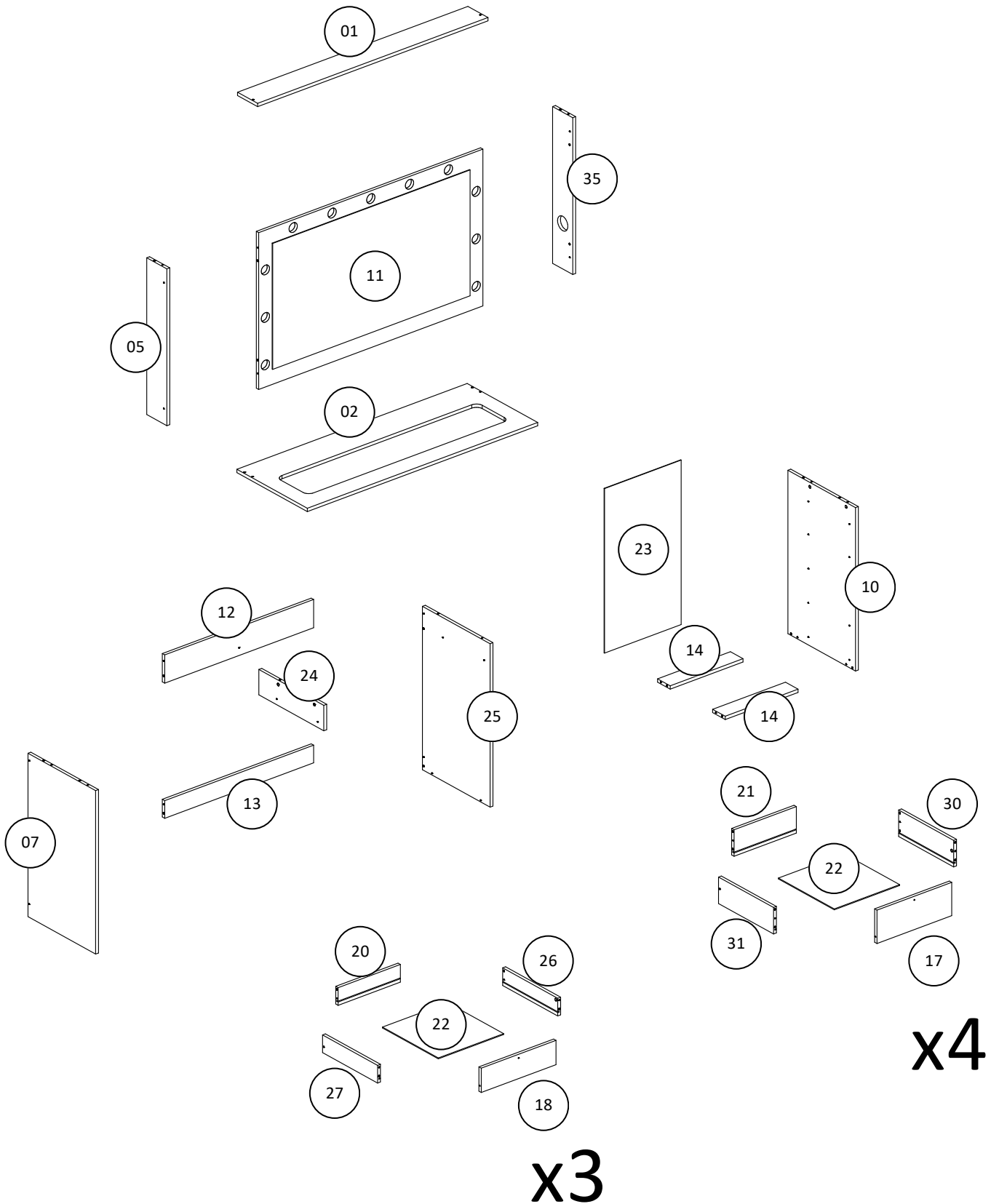



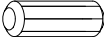
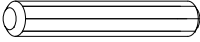

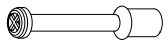

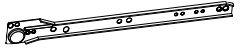



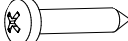
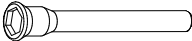

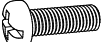

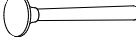
-	LB	KG
A	44	20
B	6.6	3

PARTS IDENTIFICATION / IDENTIFICACIÓN DE PARTES

Nº	DESCRIPTION - DESCRIPCIÓN	QTY.	BOX
01	Top tray/ Travesaño superior	1	2/2
02	Top base/ Base superior	1	2/2
05	Left side tray/ Travesaño lateral izquierdo	1	1/2
07	Left side/ Lateral izquierdo	1	1/2
10	Right side/ Lateral derecho	1	1/2
11	Mirror/ Espejo	1	2/2
12	Crossbeam/ Travesaño	1	2/2
13	Large footer/ Zócalo grande	1	2/2
14	Small footer/ Zócalo pequeño	2	1/2
17	Front of large drawer/ Frontal de cajón grande	4	1/2
18	Front of small drawer/ Frontal de cajón pequeño	3	2/2
20	Rear of small drawer/ Posterior de cajón pequeño	3	1/2
21	Rear of large drawer/ Posterior de cajón grande	4	1/2
22	Bottom of drawer/ Fondo de cajón	7	1/2
23	Backboard/ Fondo	1	1/2
24	Drawer divide support/ Divisoria soporte cajón	1	1/2
25	Division/ División	1	1/2
26	Side of the small right drawer/ Lateral de cajón pequeño derecha	3	1/2
27	Side of the small left drawer/ Lateral de cajón pequeño izquierda	3	1/2
30	Right side of large drawer/ Lateral derecho de cajón grande	4	1/2
31	Left side of large drawer/ Lateral izquierdo de cajón grande	4	1/2
35	Right side tray/ Travesaño lateral derecho	1	1/2

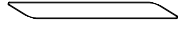

PARTS IDENTIFICATION / IDENTIFICACIÓN DE PARTES

NUMBER	IMAGE OF REFERENCE	DESCRIPTION - DESCRIPCIÓN	QTY.
A		Wooden dowel / Pin (6 x 30 mm)	60
AS		Wooden dowel / Pin (6 x 50 mm)	2
AZ		Allen key / Llave allen	1
B		Simple minifix screw / Tornillo minifix simple	22
C		Drum lock / Tambor minifix	22
CR1		Metallic left slide 350 mm/ Corredera lateral izquierda 350mm	7
CR2		Metallic right slide 350 mm/ Corredera lateral derecha 350 mm	7
CR3		Left drawer slide 350 mm/ Corredera cajón izquierda 350 mm	7
CR4		Right drawer slide 350 mm/ Corredera cajón derecha 350 mm	7
D		Flat head screw / Tornillo cabeza plana (3,5 x 14 mm)	64
G		Pan head screw / Tornillo cabeza olla (4,0 x 30 mm)	7
DZ		Structural screw/ Tornillo estructural (5 x 40 mm)	31
F		Flanged head screw/ Tornillo cabeza flageada (3,5 x 16 mm)	2
DE		Screw / Tornillo cabeza plana (4,5 x 50 mm)	2
EN		Nail/ Clavo (10 x 10 mm)	23
H		Nail/ Clavo (12 x 12 mm)	7
PX		Knob / Tirador	7
Q		Plastic angle support / Ángulo soporte plástico	2
X		Small plastic foot/ Pie plástico	7
FM		Adhesive bore patch/ Tapón adhesivo	31
Y		Adhesive bore patch / Tapón adhesivo	22
E		Clamp/ Abrazadera	1
L		Drywall Anchor/ Anclaje de pared	2
V		Mounting bracket/ Soporte de montaje	2
I		Glass/ Vidrio	1
AG		Drawer Divider / Divisor de gaveta	1



ATTENTION!!!

To facilitate the assembly process, separate and organize all boards before you start.

Para facilitar el armado, separa y organiza todas las tablas antes de empezar.

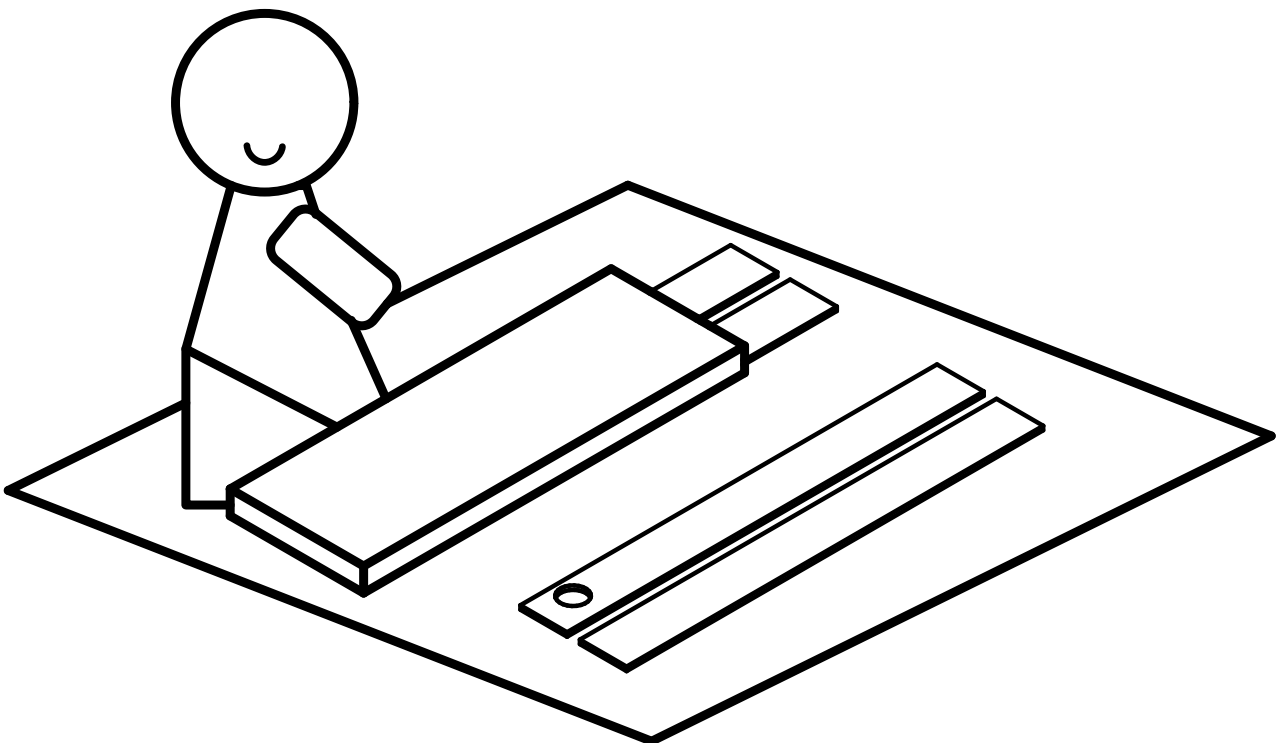

Start with the mirror pieces/Comienza con las piezas del espejo

- 1** Fix wooden dowels (A) to left side tray (05) and right side tray (35)
 Fijar pin (A) a travesaño lateral izquierdo (05) y travesaño lateral derecho (35)

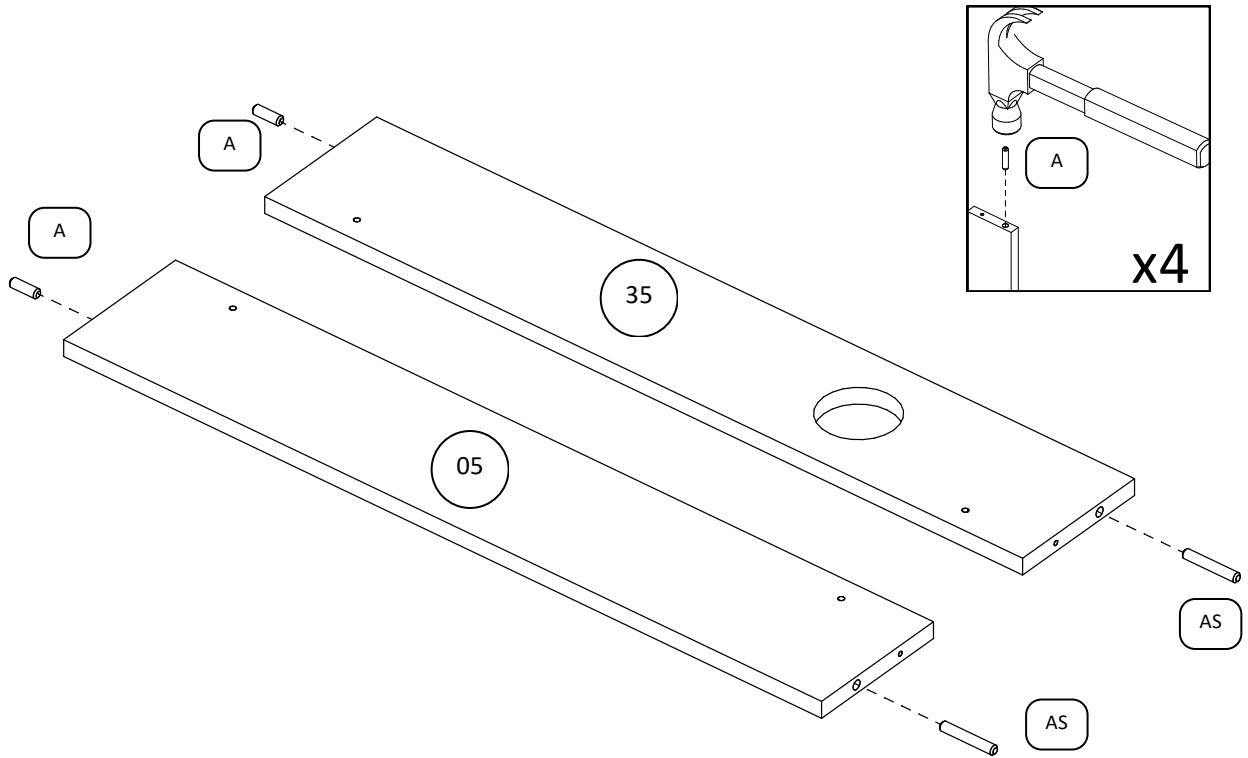

A  x2 AS  x2

- 2** Fix wooden dowels (A) to mirror (11)
 Fijar pines (A) al espejo (11)

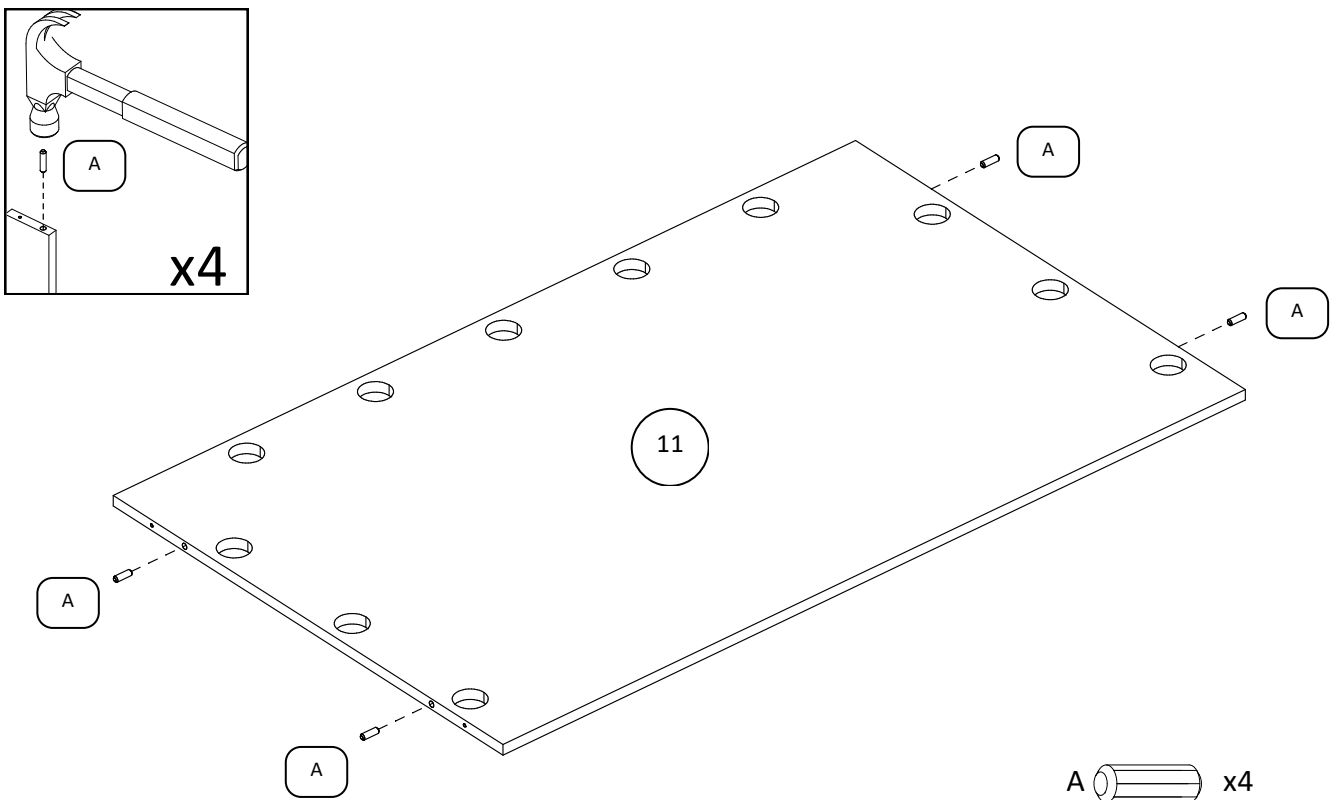

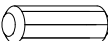
A  x4

3 Fix left side tray (05) and right side tray (35) to mirror (11) with structural screw (DZ)
 Fijar travesaño lateral izquierdo (05) y travesaño lateral derecho (35) a espejo (11) con tornillo estructural (DZ)

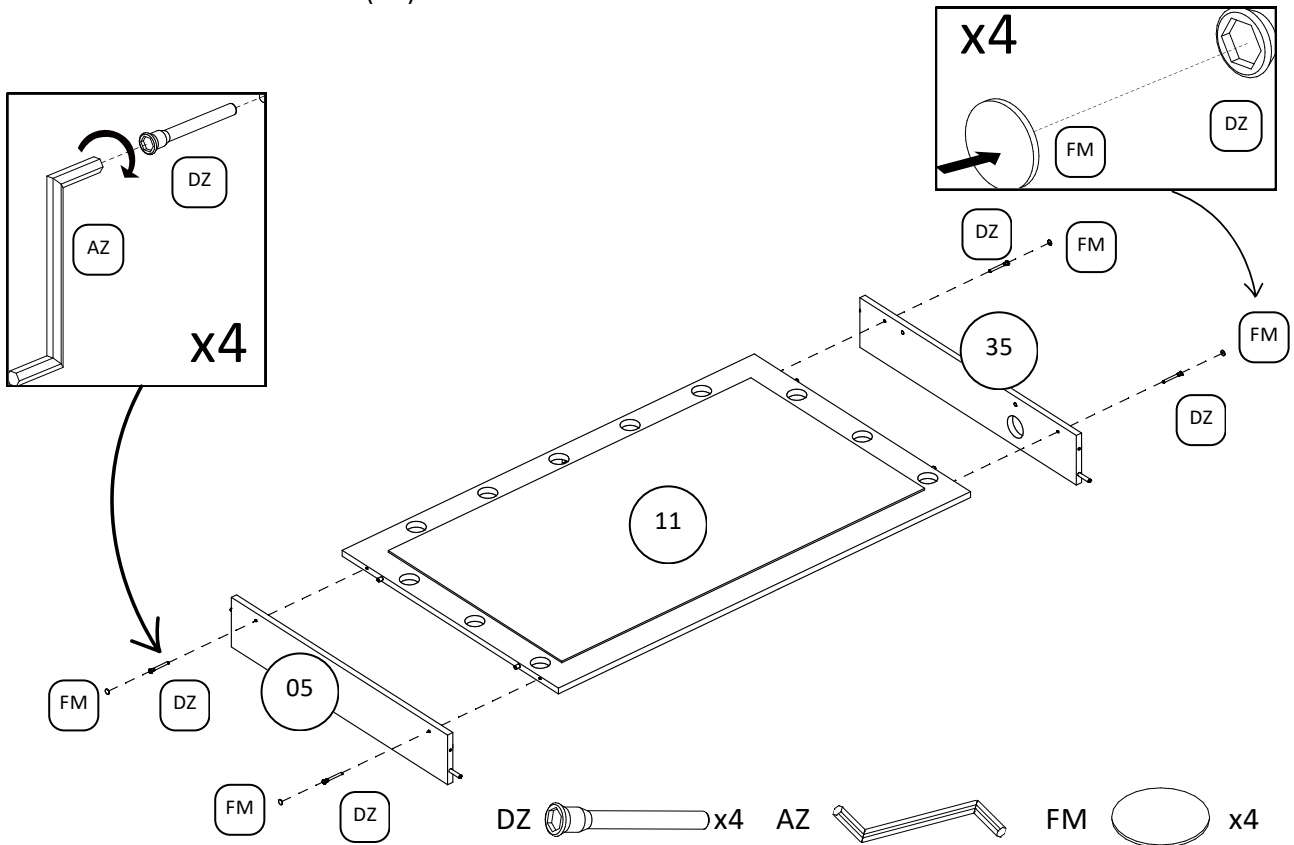

4 Fix top tray (01) to previous assembly with structural screw (DZ)
 Fijar travesaño superior (01) a ensamble previo con tornillo estructural (DZ)

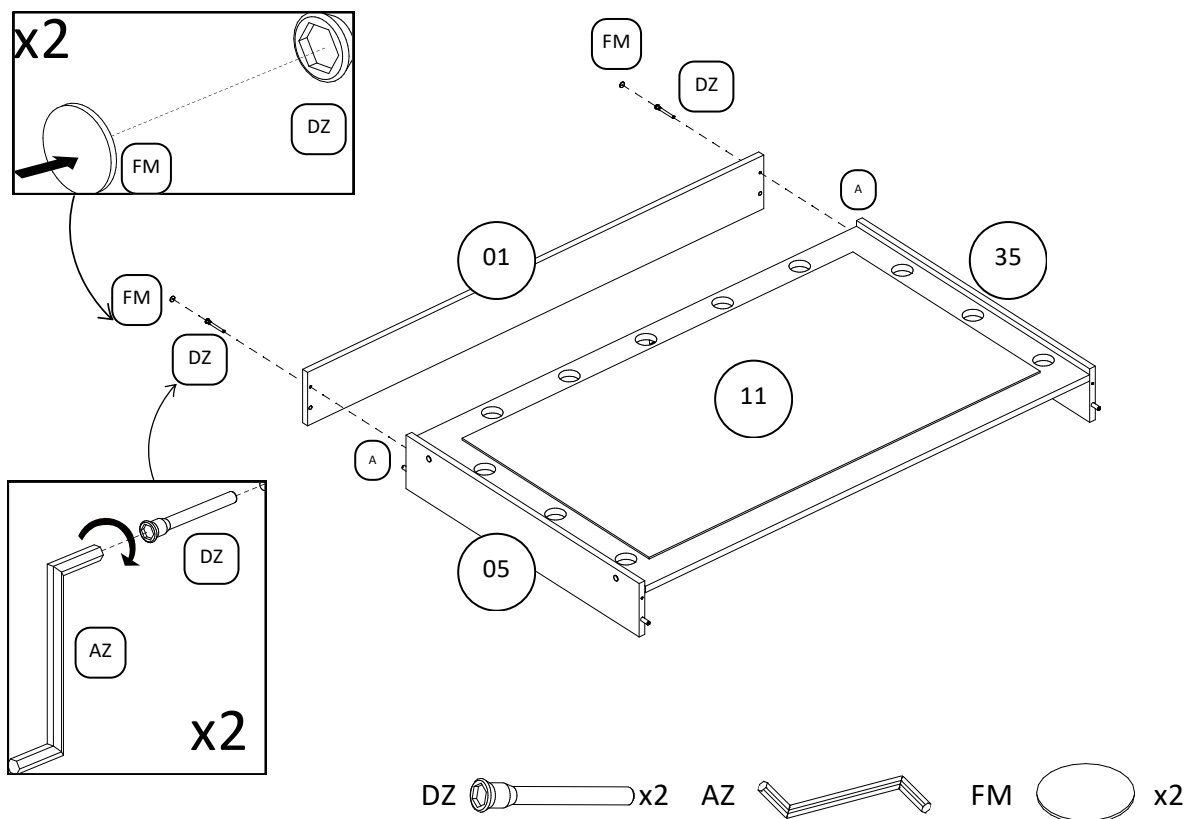

5 Fix simple minifix screw (B) to top base (02)
 Fijar tornillo minifix simple (B) a base superior (02)

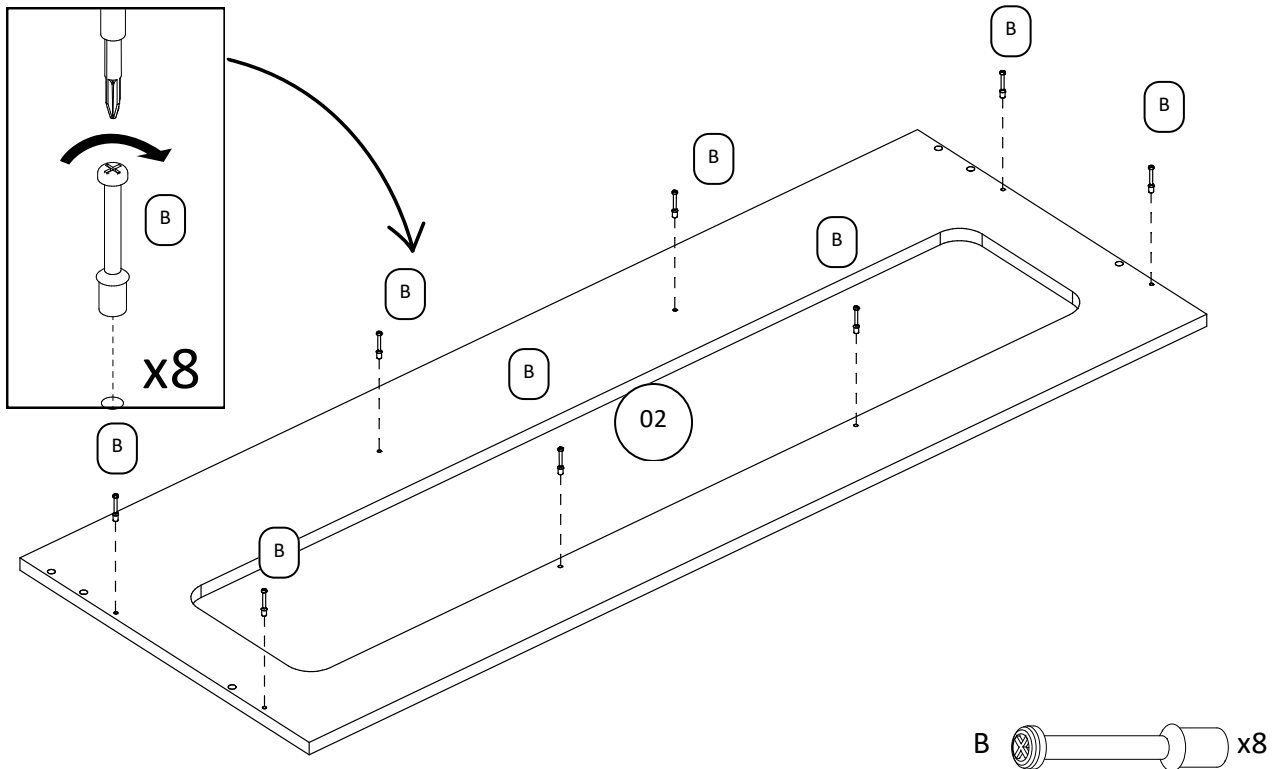

6 Fix top base (02) to previous assembly mirror with structural screw (DZ)
 Fijar base superior (02) a ensamble previo del espejo con tornillo estructural (DZ)

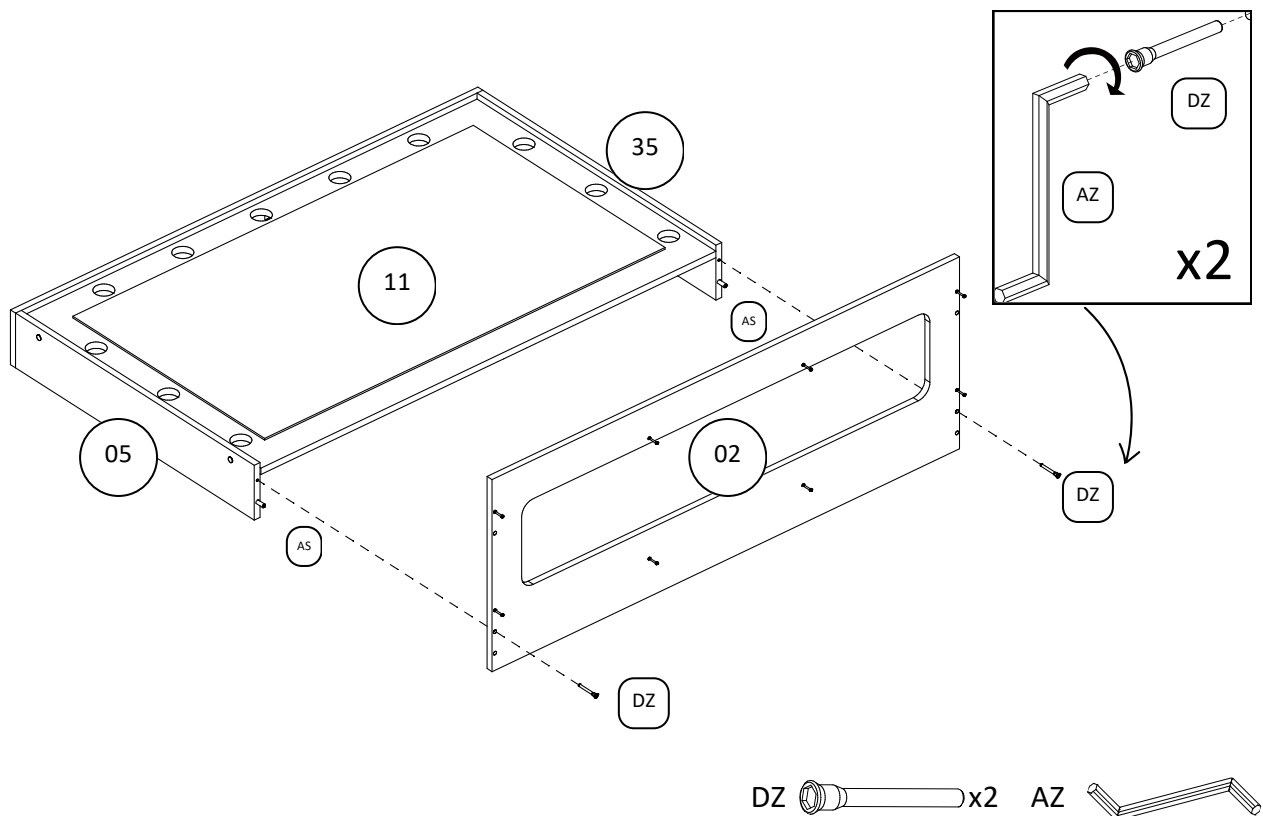

Before proceeding to the next step please separate all the pieces of metallic left slides and metallic right slides, as shown in the following image.

Antes de continuar con el siguiente paso por favor separe todas las piezas de correderas metálicas izquierdas y correderas metálicas derechas, como se muestra en la imagen

Left

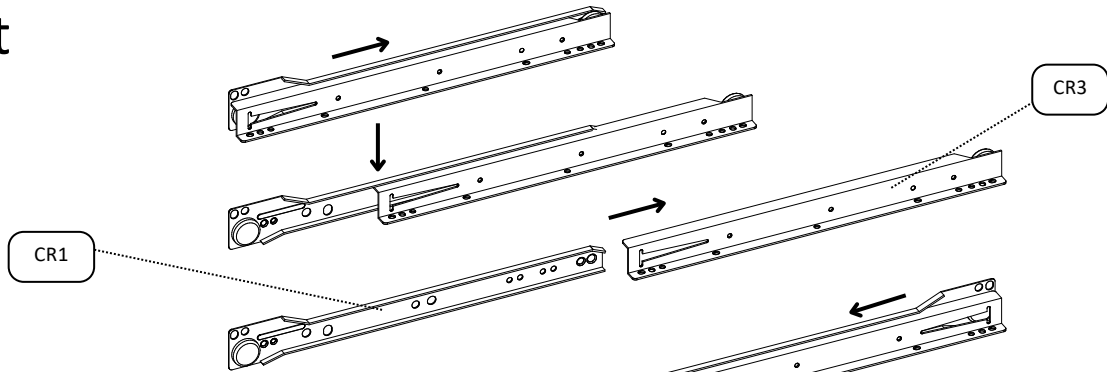

Right

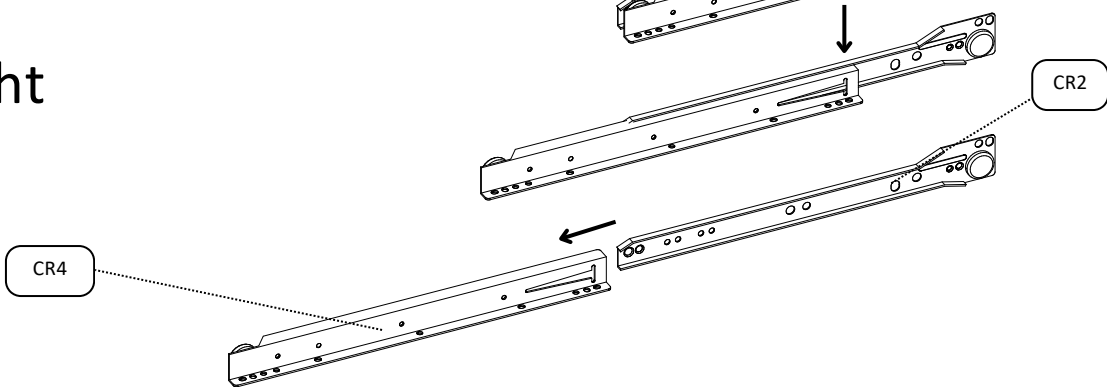

Continue with the left side/Continúa con lateral izquierdo

7 Fix wooden dowel (A) and metallic left slide (CR1) to left side (07) with flat head screw (D)
Fijar pin (A) y corredera lateral izquierda (CR1) a lateral izquierdo (07) con tornillo cabeza plana (D)

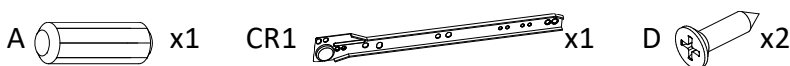
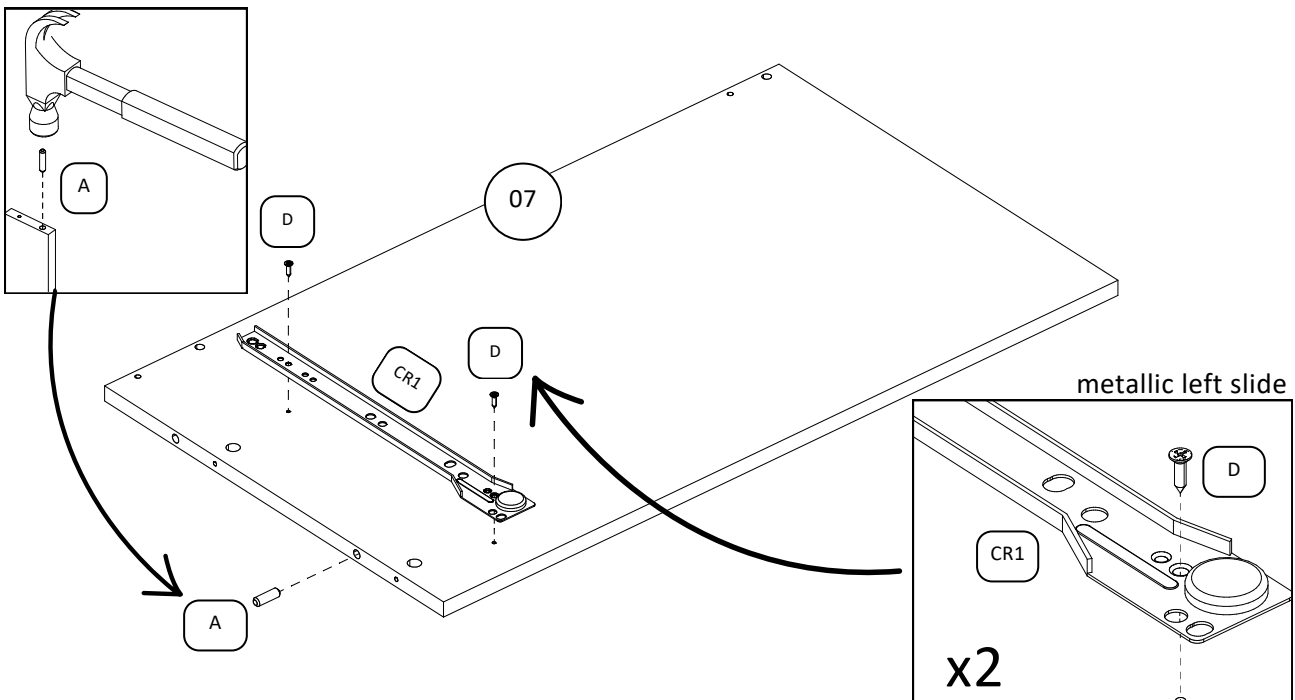

Continue with drawer divide support/Continúa con divisoria soporte cajón

- 8** Fix metallic right slide (CR2) to drawer divide support (24) with flat head screw (D)
 Fijar corredera lateral derecha (CR2) a divisoria soporte cajón (24) con tornillo cabeza plana (D)

metallic right slide

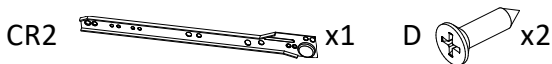
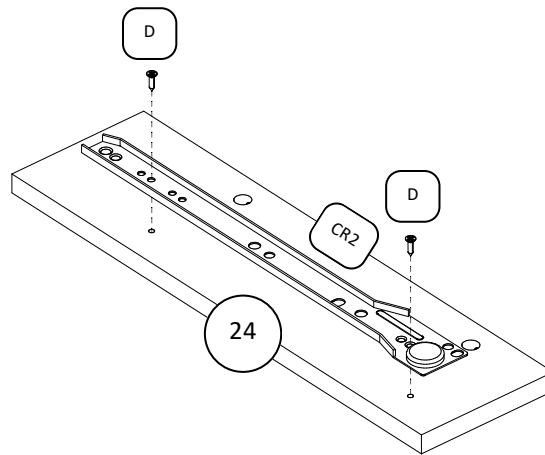
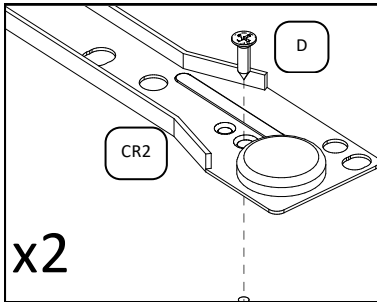

- 9** Flip drawer divide support (24) and fix metallic left slide (CR1) with flat head screw (D)
 Voltear divisoria soporte cajón (24) y fijar corredera lateral izquierda (CR1) con tornillo cabeza plana (D)

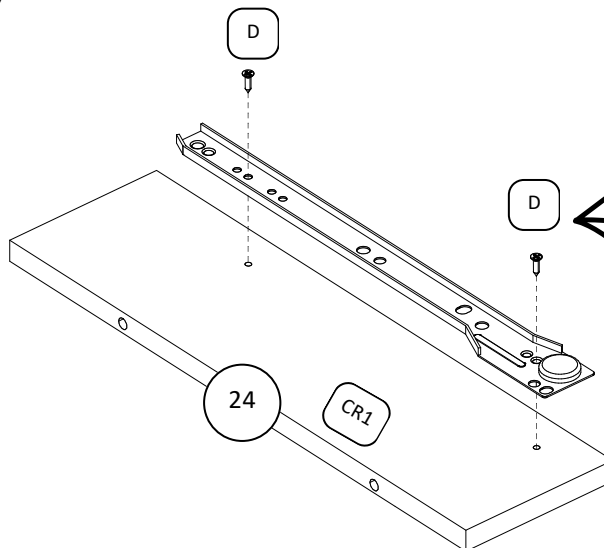

metallic left slide

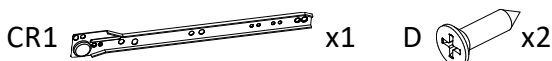
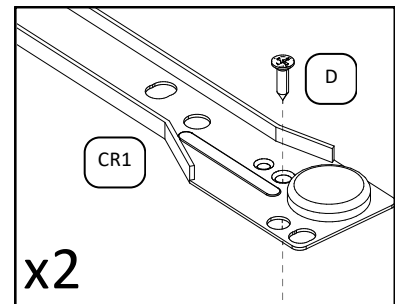

Continue with division/Continúa con división

10 Fix metallic left slide (CR1) to division (25) with flat head screw (D)
 Fijar corredera lateral izquierda (CR1) a división (25) con tornillo cabeza plana (D)

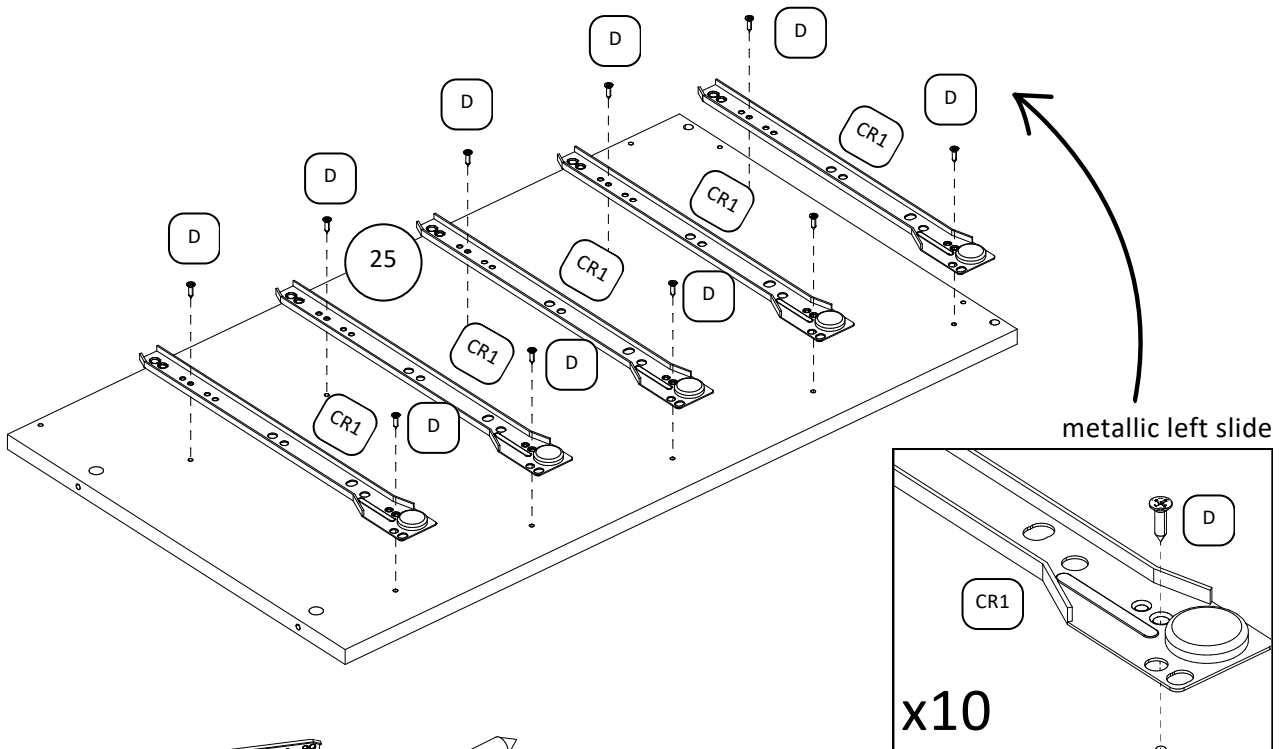

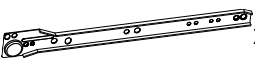
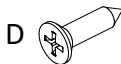
CR1  x5 D  x10

11 Flip division (25) and fix metallic right slide (CR2) with flat head screw (D)
 Voltear división (25) y fijar corredera lateral derecha (CR2) con tornillo cabeza plana (D)

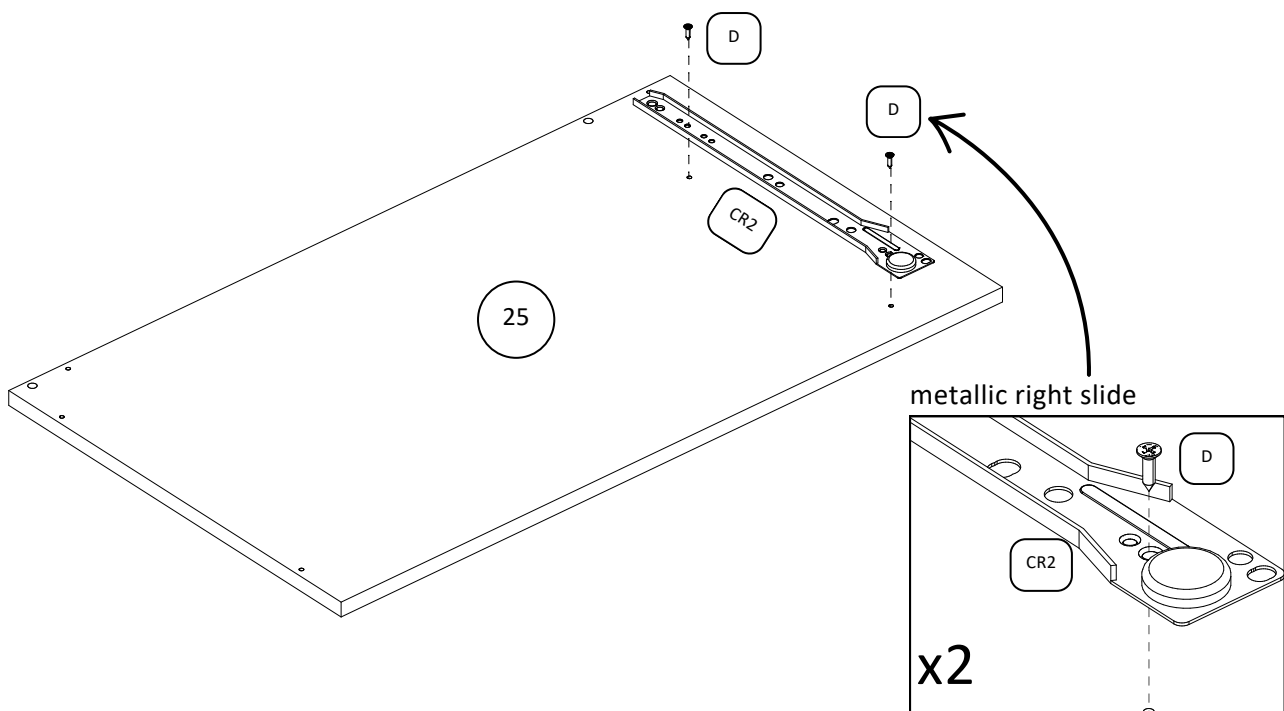

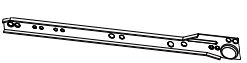
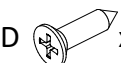
CR2  x1 D  x2

Continue with right side/Continúa con lateral derecho

12 Fix wooden dowel (A) and metallic right slide (CR2) to right side (10) with flat head screw (D)
 Fijar pin (A) y corredera lateral derecha (CR2) a lateral derecho (10) con tornillo cabeza plana (D)

metallic right slide

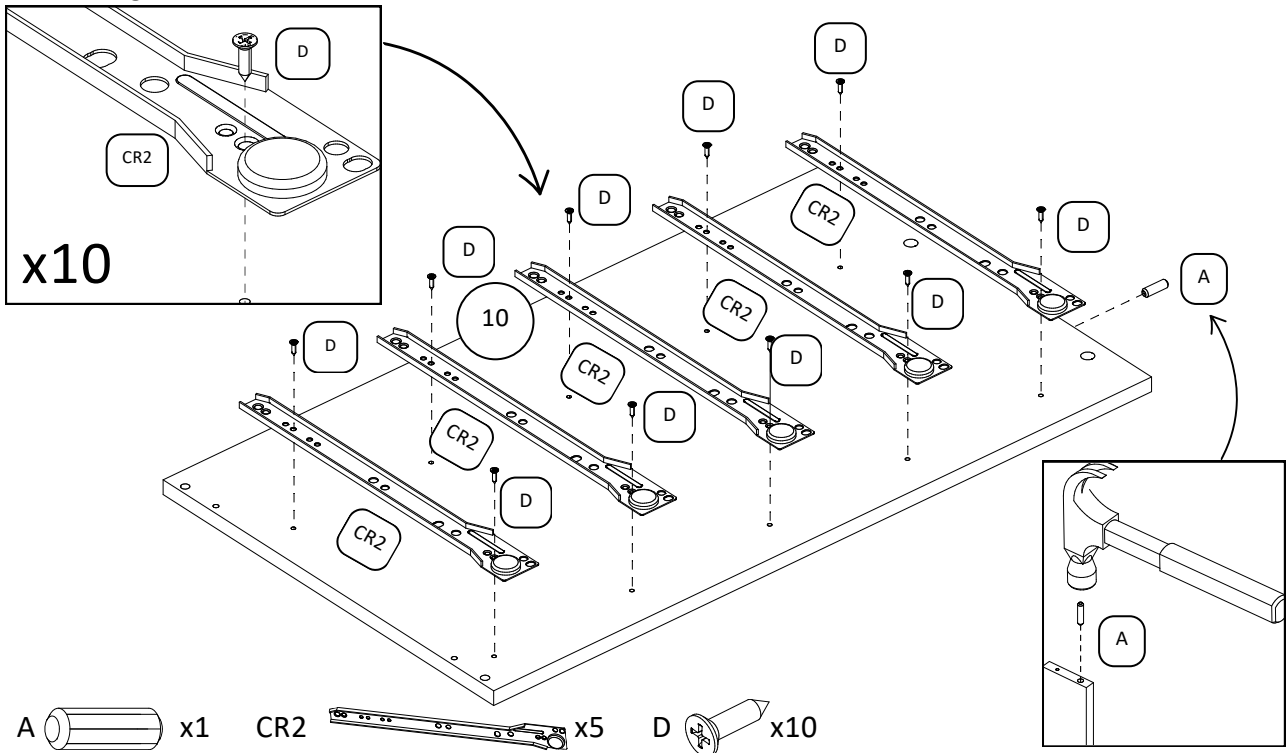

Continue with crossbeam and footers/Continúa con los zócalos y travesaño

13 Fix wooden dowels (A) to crossbeam (12) and small footer (14)x2
 Fijar pin (A) a travesaño (12) y a zócalo pequeño (14)x2

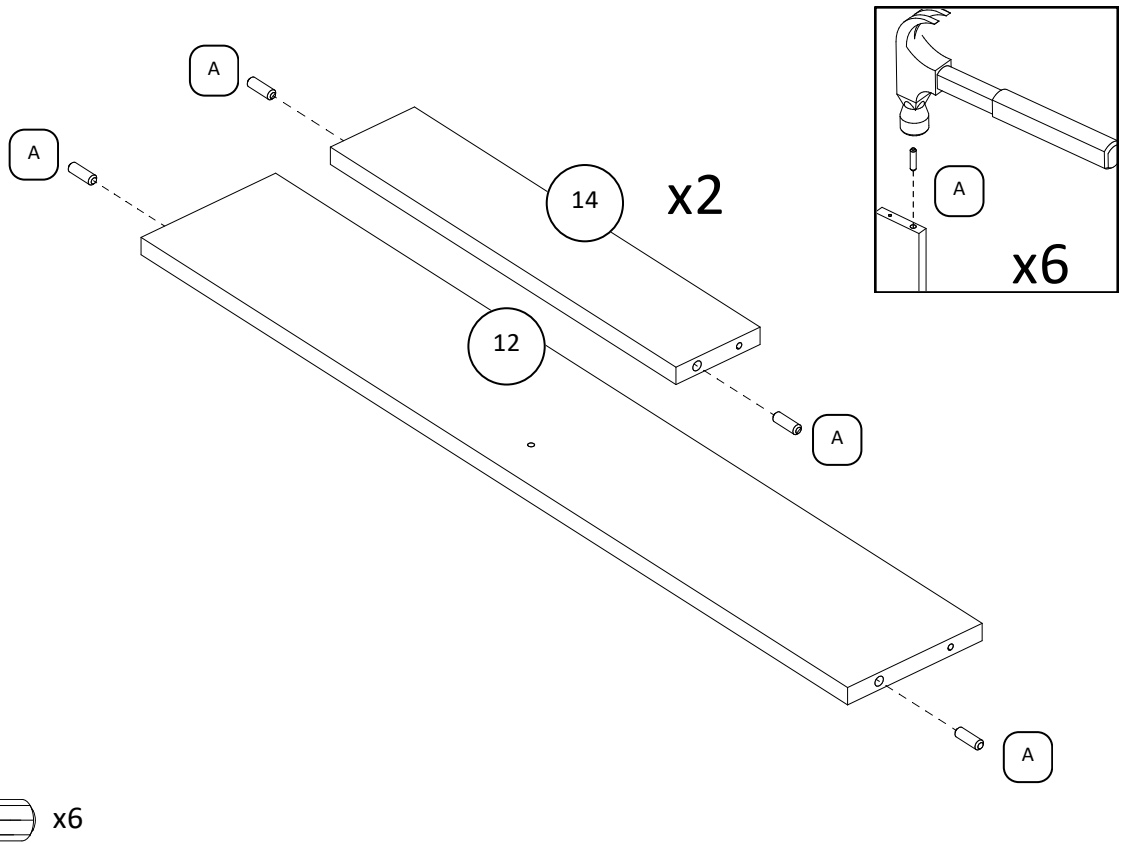

14 Fix wooden dowels (A) and plastic foot (X) with nails (H) to large footer (13)
 Fijar pin (A) y pie plástico (X) con clavos (H) con zócalo grande (13)

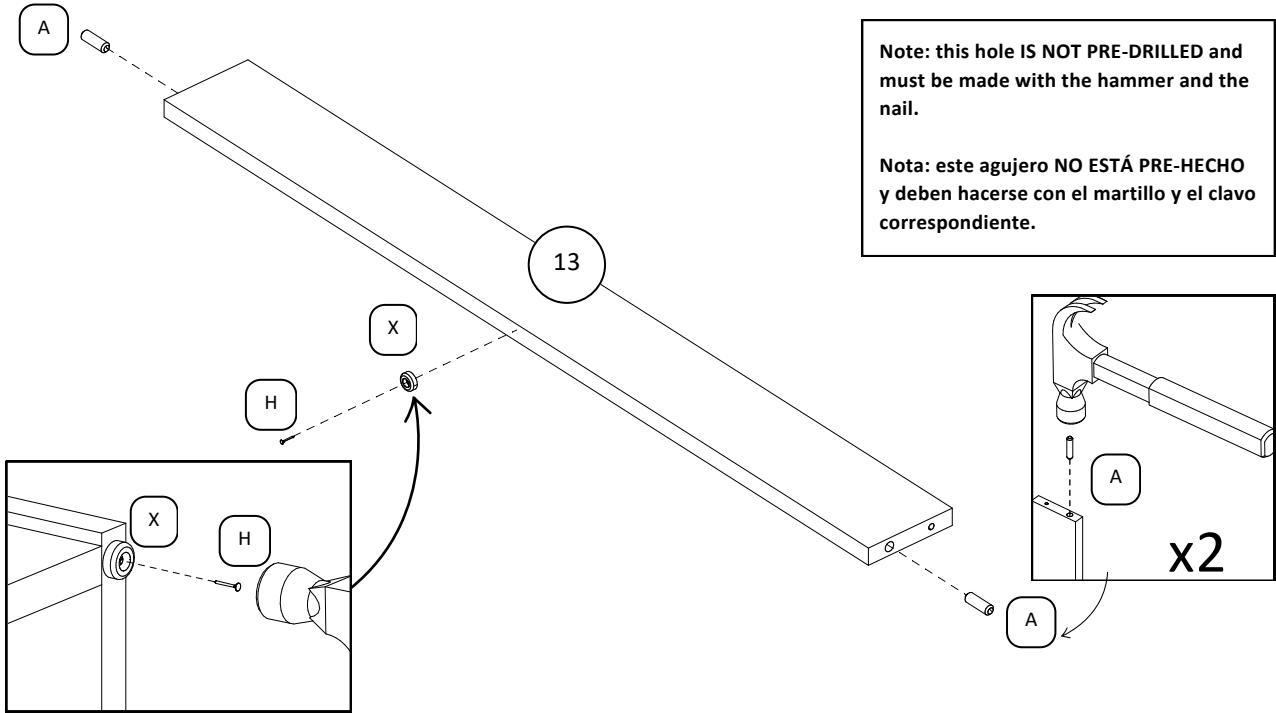

- A x2
- H x1
- X x1

Let's assemble sides and divisions! ¡A armar los lados y divisiones!

15 Fix crossbeam (12) and large footer (13) to left side (07) and division (25) with structural screw (DZ)
 Fijar travesaño (12) y zócalo grande (13) a lateral izquierdo (07) y división (25) con tornillo estructural (DZ)

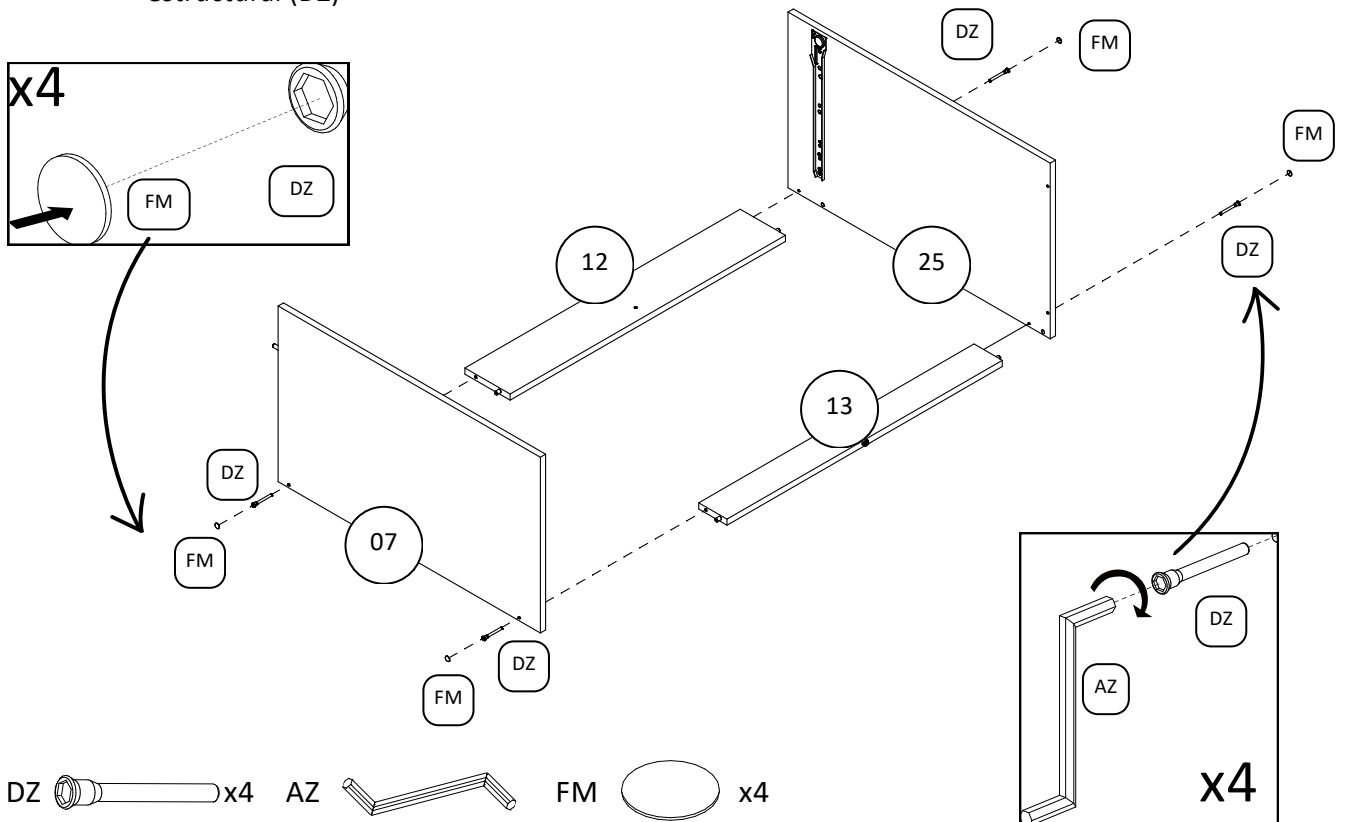

- DZ x4
- AZ x4
- FM x4

16 Fix small footer (14)x2 and right side (10) to previous assembly with structural screw (DZ)
 Fijar zócalo pequeño (14)x2 y lateral derecho (10) a ensamble previo con tornillo estructural (DZ)

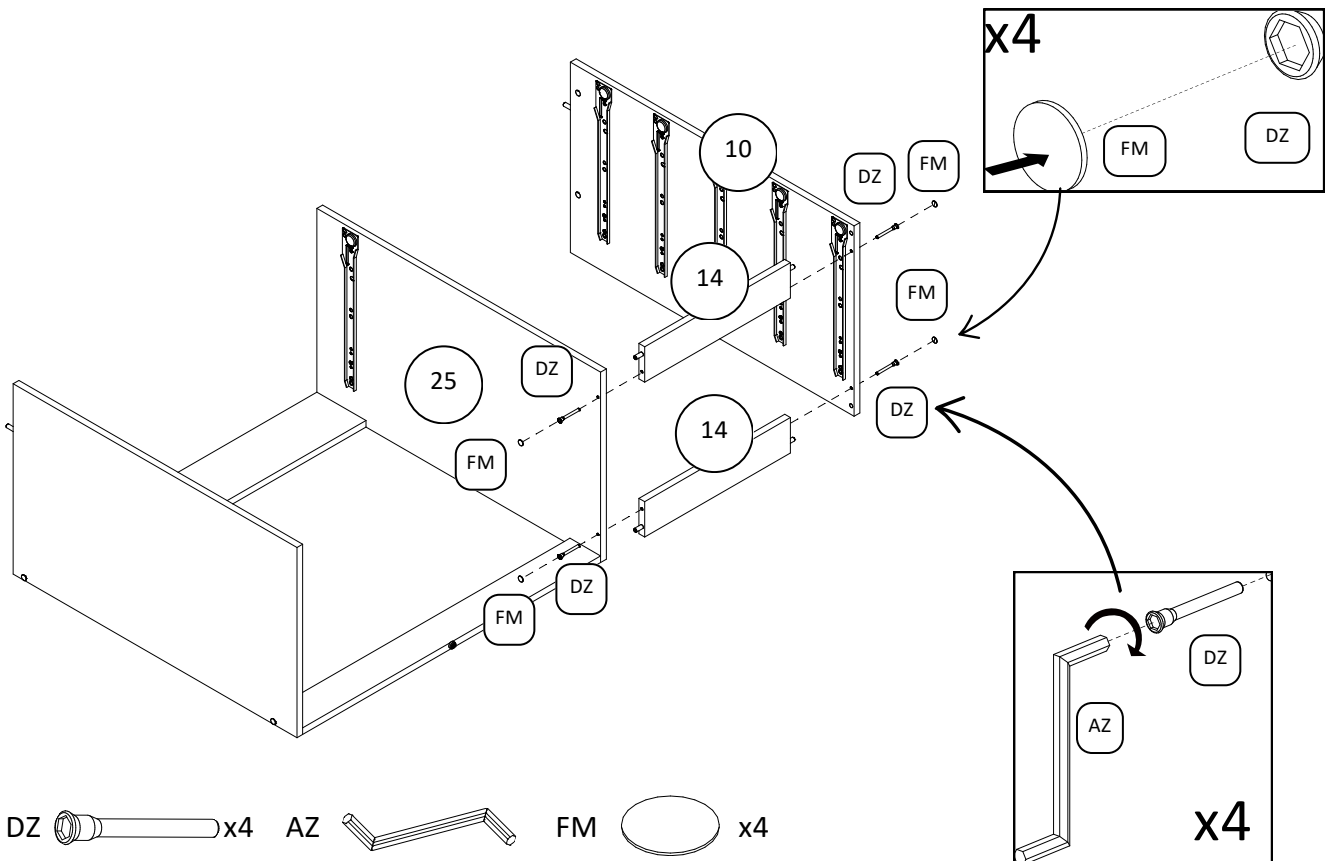

17 Fix both previous assemblies with drum lock (C)
 Fijar ambos ensambles previos con tambor minifix (C)

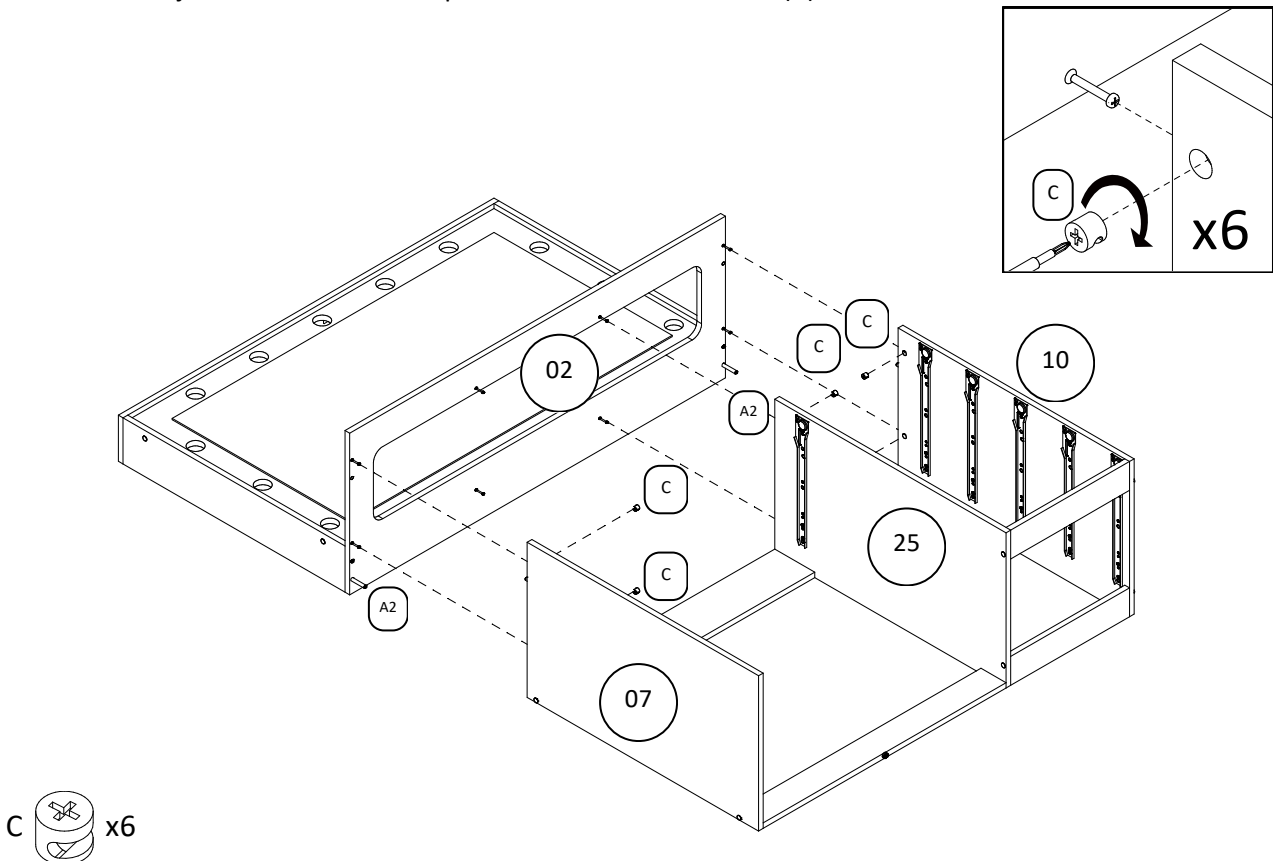

18 Fix drawer divide support (24) to previous assembly with drum lock (D)
 Fijar divisoria soporte cajón (24) a ensamble previo con tambor minifix (D)

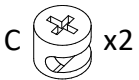
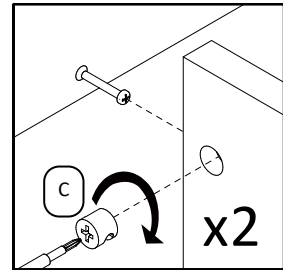
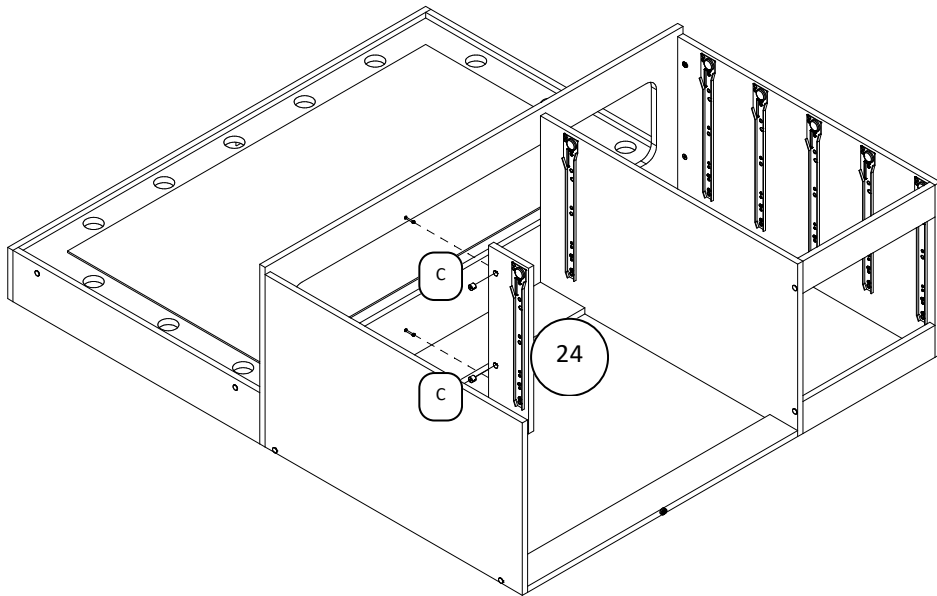

19 Fix plastic foot (X) with nails (H) to previous assembly
 Fijar pie plástico (X) con clavos (H) al ensamble previo

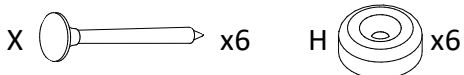
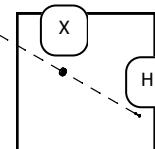
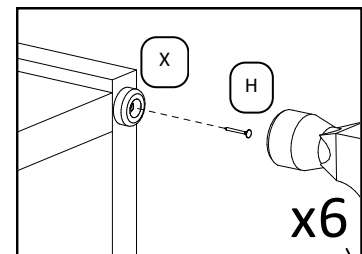
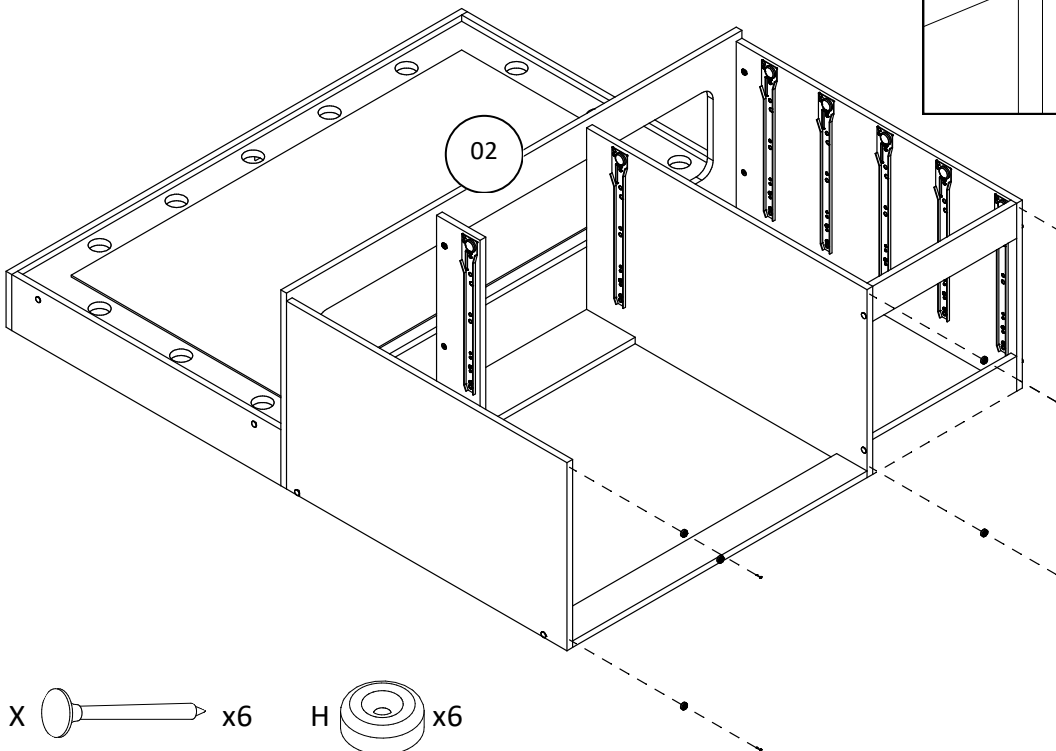

Stand out the assembly and rotate/Levántalo y rótaló

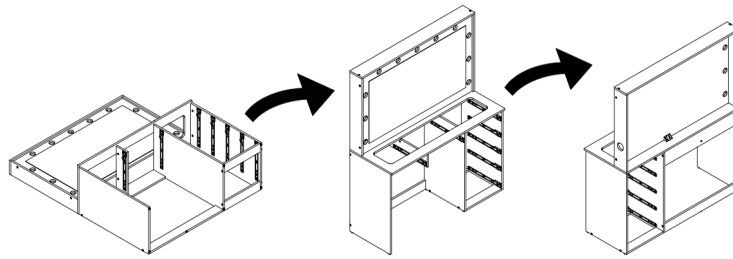

Almost done!/¡Casi listo!

20 Fix **backboard (23)** with nails (EN) and structural screw (DZ) to previous assembly
 Fijar **fondo (23)** con clavos (EN) y el tornillo estructural (DZ) a ensamble previo

Note: this hole IS NOT PRE-DRILLED and must be made with the hammer and the nail.
 Nota: este agujero NO ESTÁ PRE-HECHO y deben hacerse con el martillo y el clavo correspondiente.

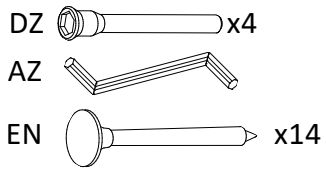
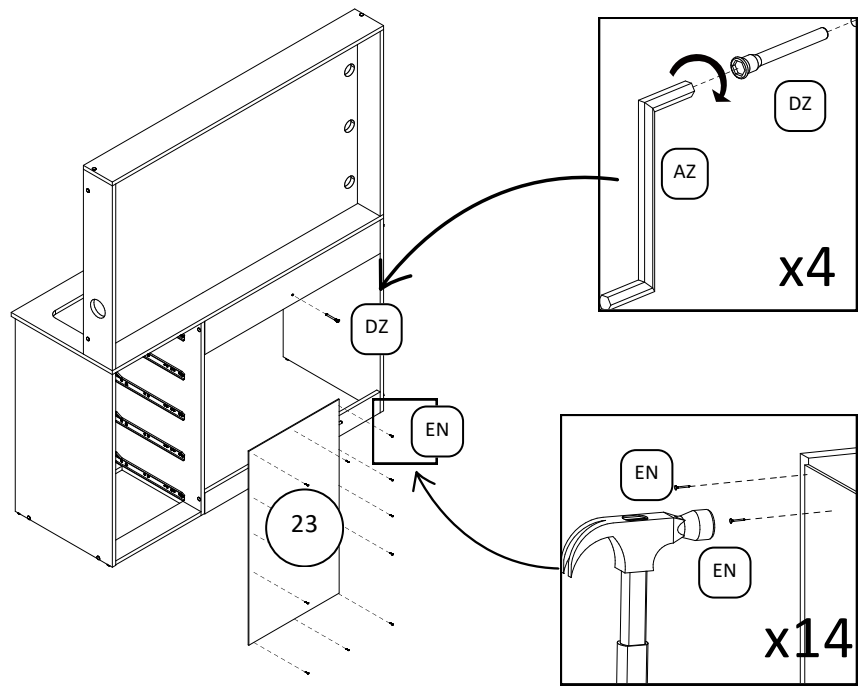

21 Fix **mirror (11)** to previous assembly with flat head screw (D)
 Fijar **espejo (11)** a ensamble previo con tornillo cabeza plana (D)

Note: these holes ARE NOT PRE-DRILLED and must be made with the screwdriver and the corresponding screw.
 Nota: estos agujeros NO ESTAN PRE-HECHOS y deben hacerse con el destornillador y el tornillo correspondiente.

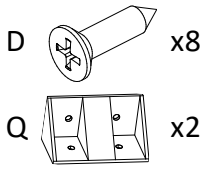
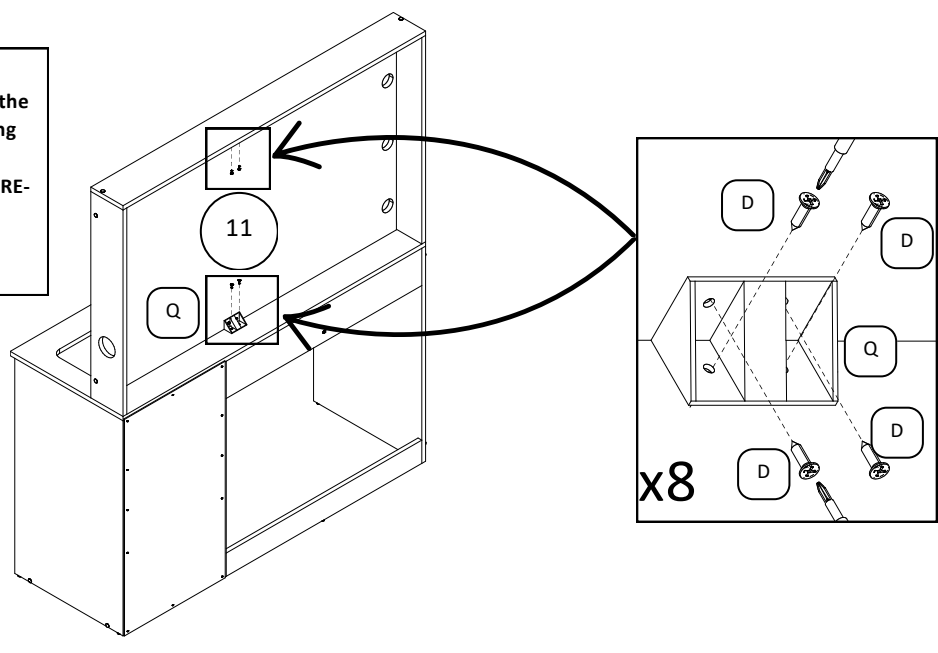

Continue with the drawers/Continúa con los cajones

22

Fix wooden dowels (A) to sides of drawers (30/31)x4 and side drawers (26/27)x3
 Fijar pines (A) al laterales del cajón grande (30/31)x4 y al laterales del cajón pequeño (26/27)x3

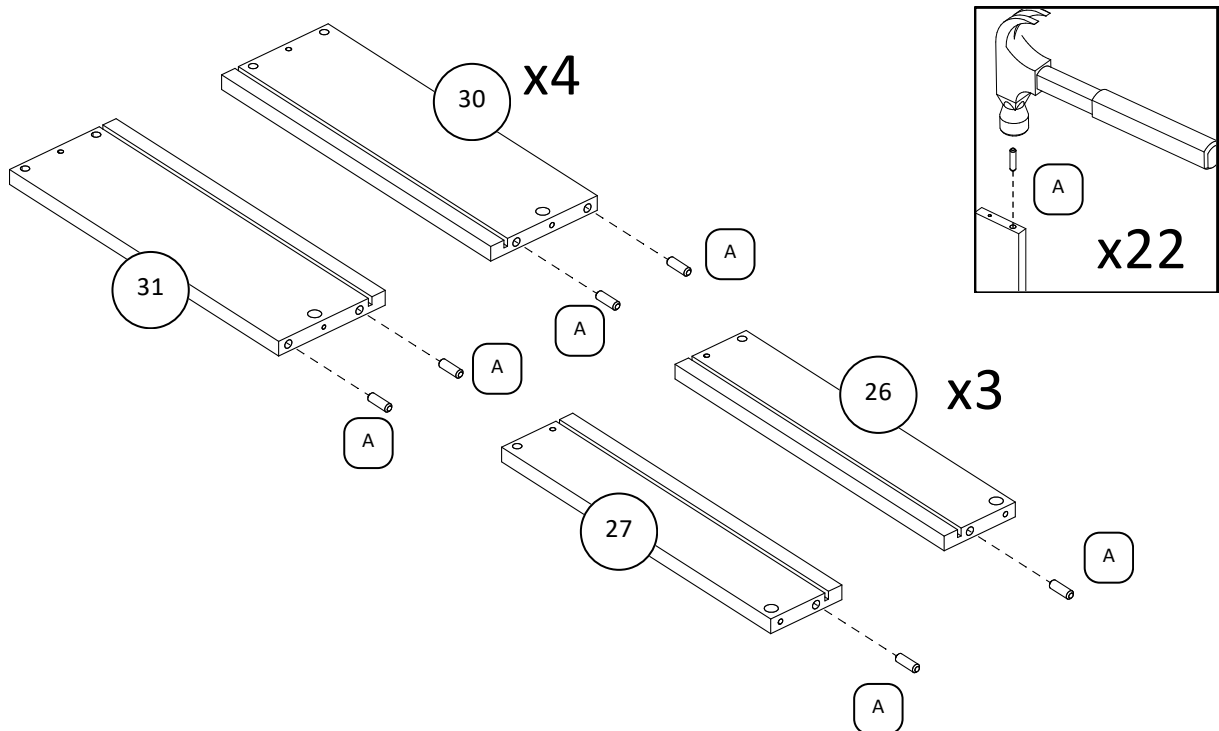

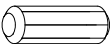
A  x22

23

Fix wooden dowels (A) to rears of large drawer (21)x4 and rears of small drawer (20)x3
 Fijar el pines (A) al posteriores de cajón grande (21)x4 y al posteriores de cajón pequeño (20)x3

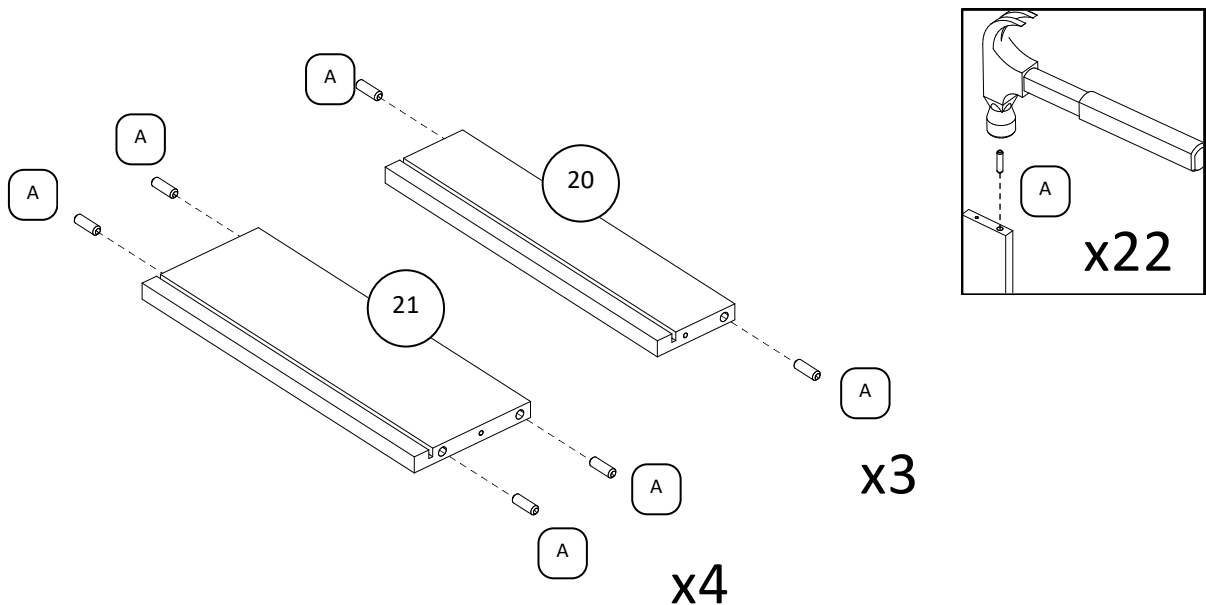

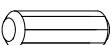
A  x22

24 Fix simple minifix screw (B) to front of large drawer (17)x4 and front of small drawer (18)x3
 Fijar tornillo minifix simple (B) a frente de cajón grande (17)x4 y frente de cajón pequeño (18)x3

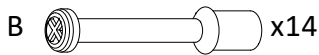
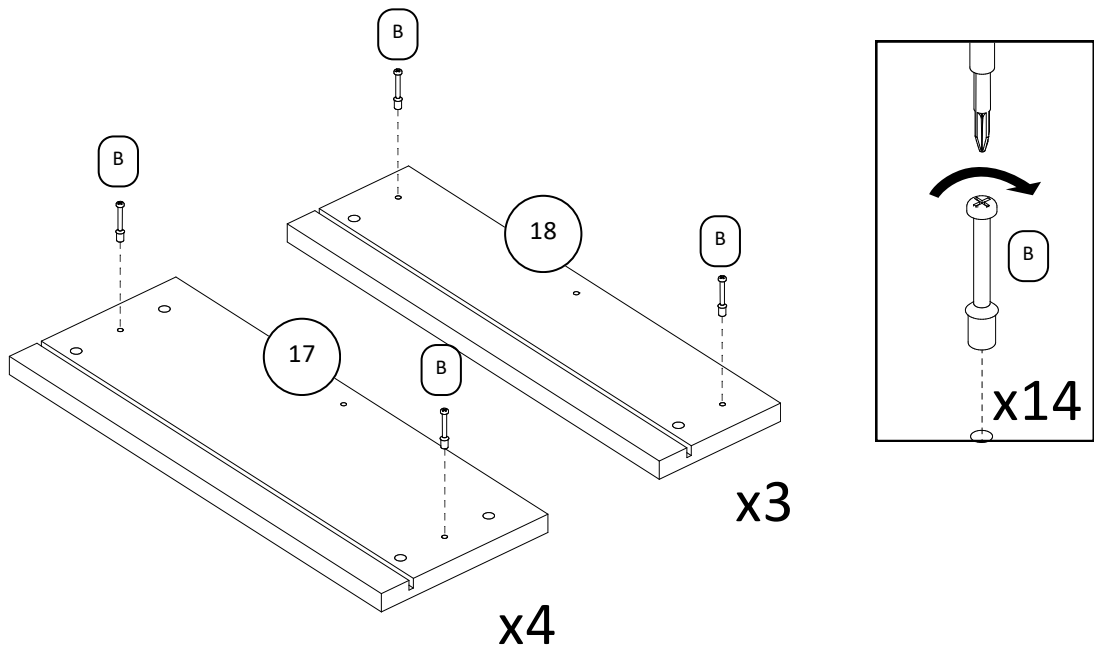

Let's assemble the large drawers! / ¡A armar los cajones grandes!

25 Fix sides of drawer (30/31) and bottoms of drawer (22) to rear of drawer (21) with structural screw (DZ)
 Fijar laterales de cajón central (30/31) y fondos de cajón (22) a trasero de cajón (21) con tornillo estructural (DZ)

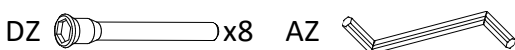
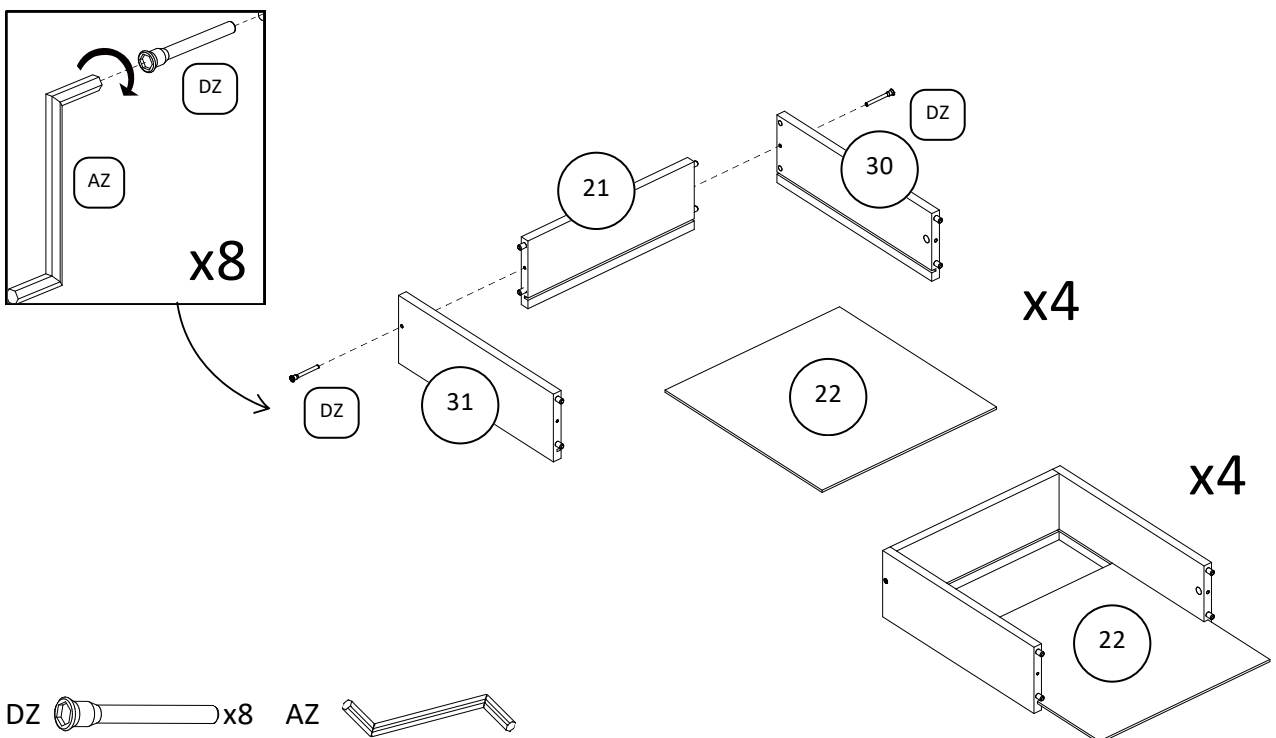

26

Fix front large drawer (17)x4 to previous assembly with drum lock (D) and fix knob (PX)x4 with pan head screw (G)

Fijar frente del cajón grande (17)x4 a ensamble previo con tambor minifix (D) e inserta el tirador (PX)x4 con tornillo cabeza de olla (G)

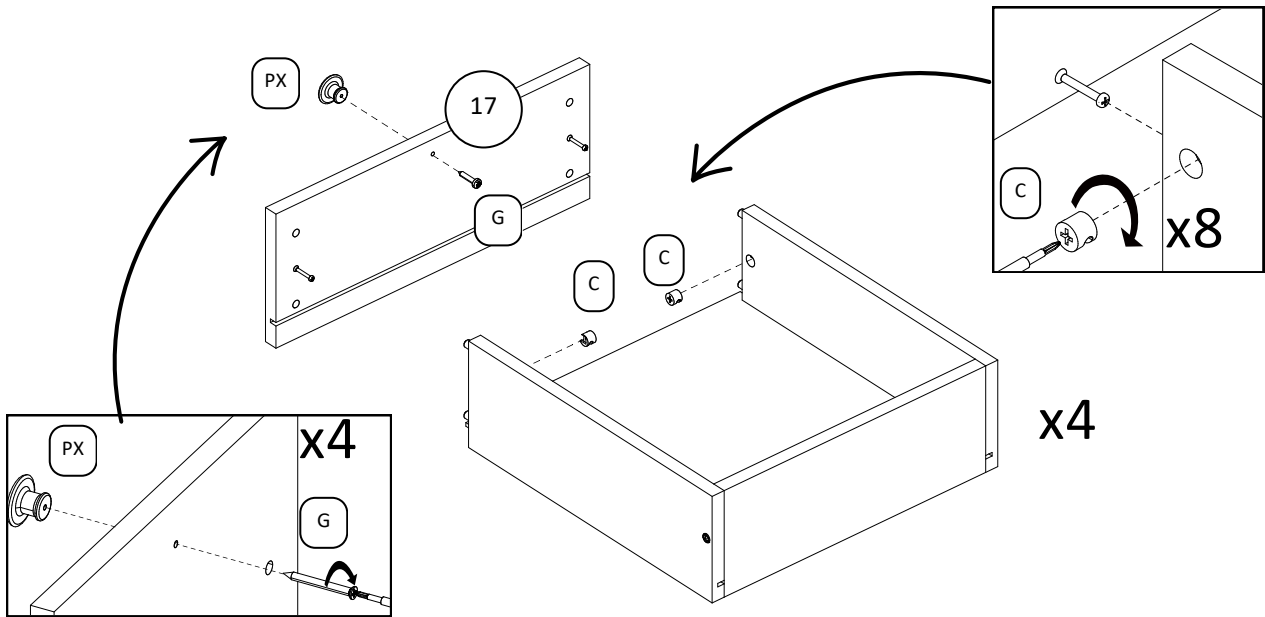

Flip the drawer/Voltea el cajón

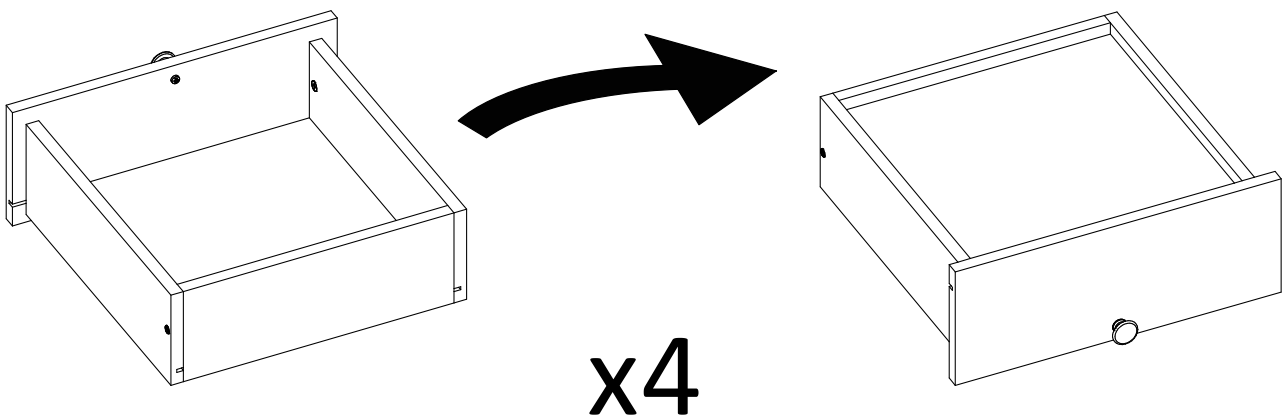

27

Fix left drawer slide (CR3)x4 and right drawer slide (CR4)x4 to large drawer x4 with flat head screw (D)

Fijar **corredera de cajón izquierdo (CR3)x4** y **corredera de cajón derecho (CR4)x4** a **cajón grande x4** con tornillo cabeza plana (D)

Note: these holes ARE NOT PRE-DRILLED and must be made with the screwdriver and the corresponding screw.

Nota: estos agujeros NO ESTAN PRE-HECHOS y deben hacerse con el destornillador y el tornillo correspondiente.

left drawer slide

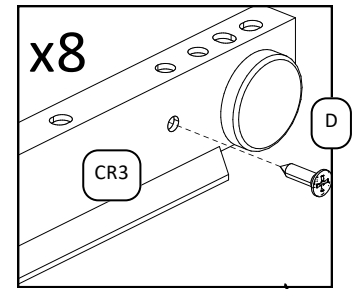

right drawer slide

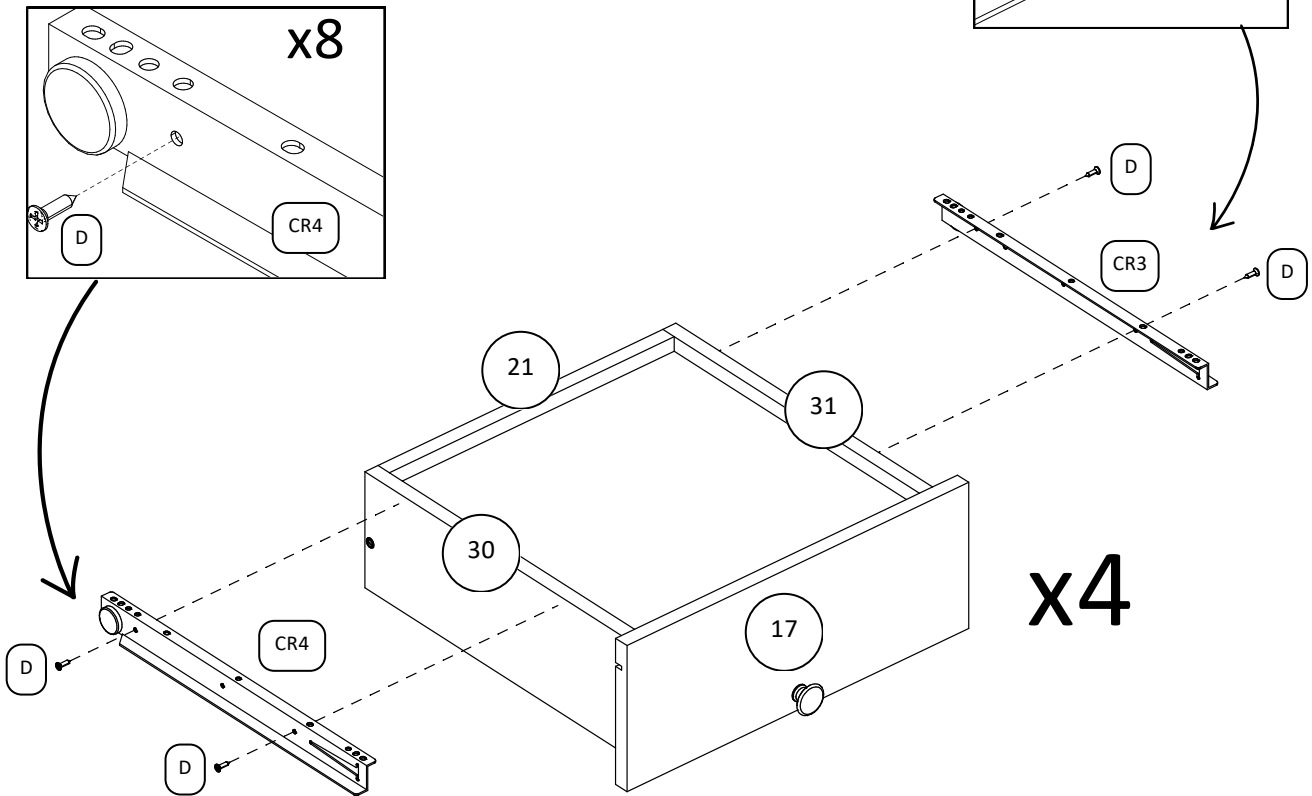
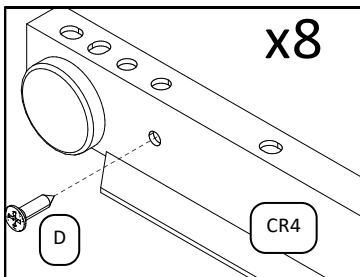

Ready!

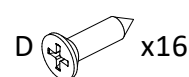
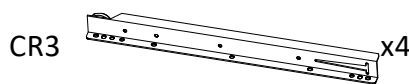
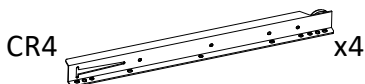
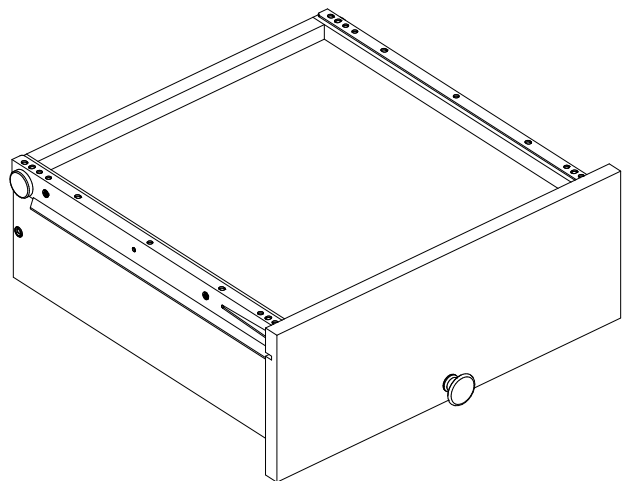

Continue with smaller drawers/Continúa con los cajones pequeños

28

Fix small drawers (26/27)x6 to the rear of the small drawer (20)x3 with structural screw (DZ)
 Fijar lateral del cajón pequeño (26/27)x6 en la parte posterior del cajón pequeño (20)x3 con tornillo estructural (DZ)

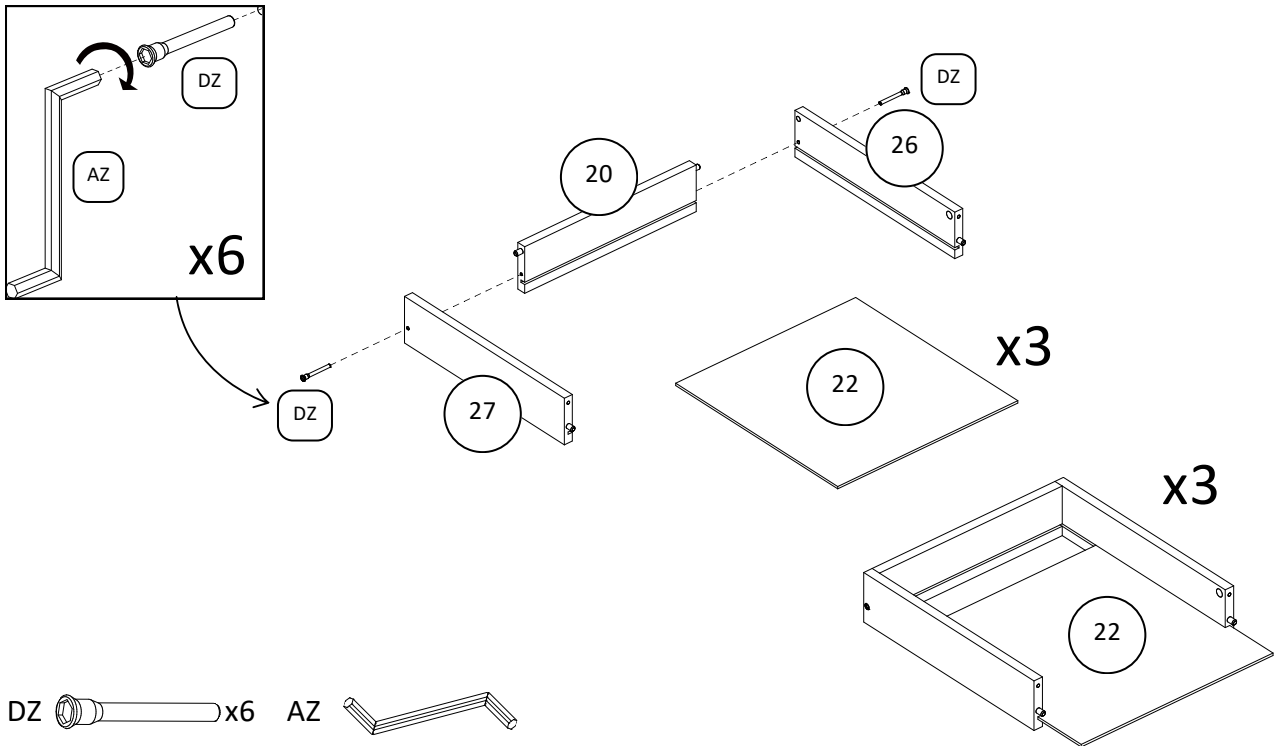

29

Fix smaller drawer front (18)x3 to previous assembly with drum lock (C) and fix knob (PX)x3 with screw (G)
 Fijar frente de cajón estrecho pequeño (18)x3 a ensamble previo con tambor minifix (C) e inserta el tirador (PX)x3 con tornillo (G)

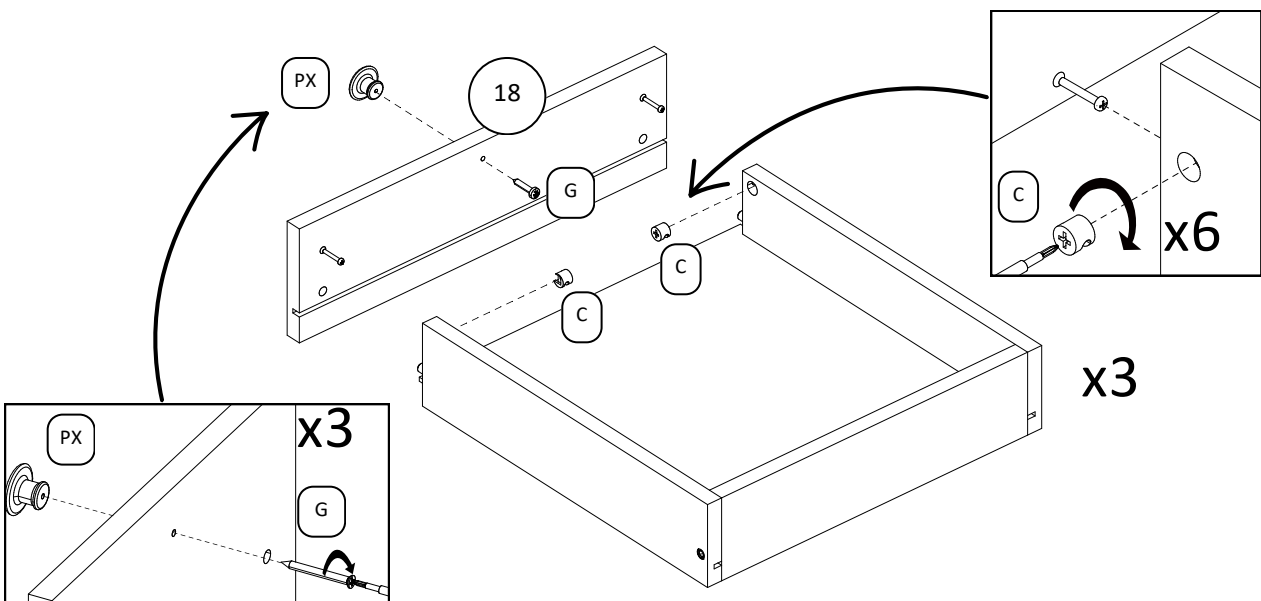

Flip the central drawer/Voltea el cajón central

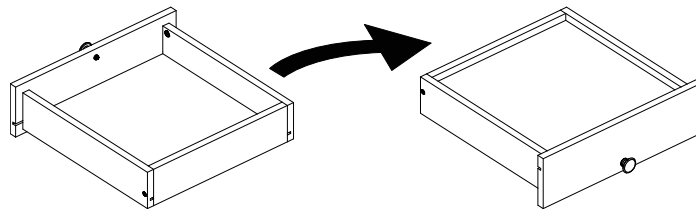

30

Fix left drawer slide (CR3)x3 and right drawer slide (CR4)x3 to small drawer x3 with flat head screw (D)

Fijar corredera de cajón izquierdo (CR3)x3 y corredera de cajón derecho (CR4)x3 a cajón pequeño x3 con tornillo cabeza plana (D)

Note: these holes ARE NOT PRE-DRILLED and must be made with the screwdriver and the corresponding screw.

Nota: estos agujeros NO ESTAN PRE-HECHOS y deben hacerse con el destornillador y el tornillo correspondiente.

left drawer slide

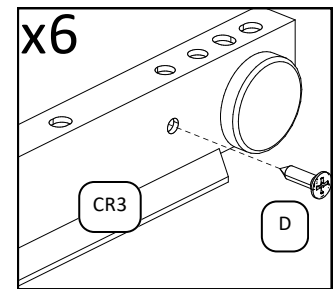

right drawer slide

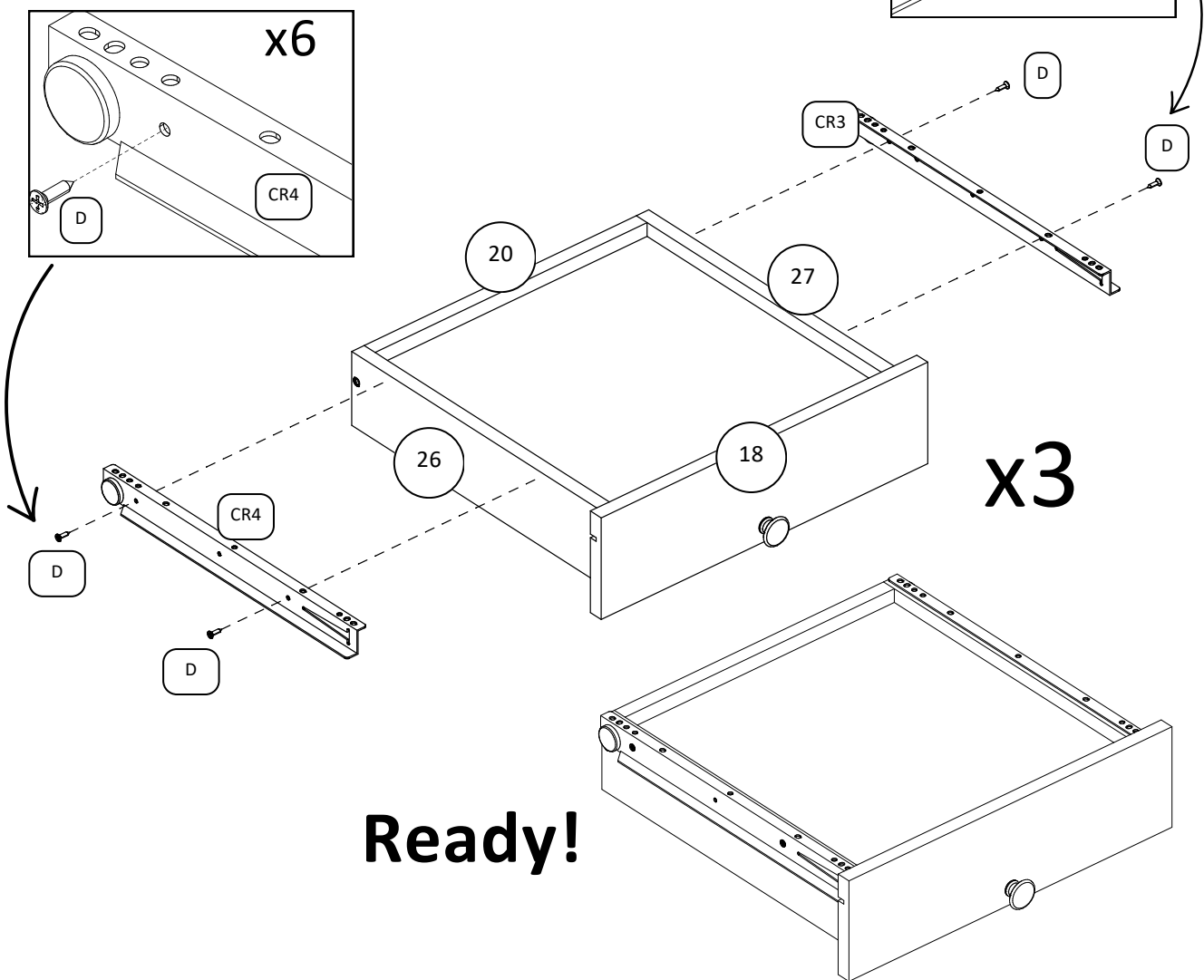
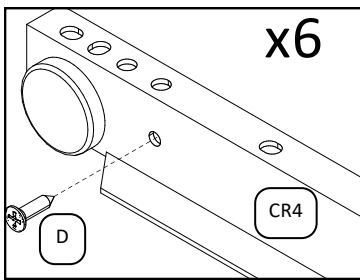

Ready!

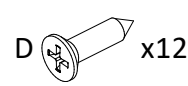
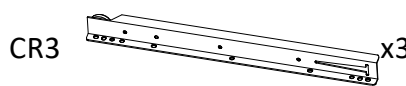
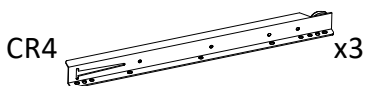

We're almost done! ¡Estamos casi listos!

32 Install outlet to right side tray (35)
Instala el enchufe al travesaño lateral derecho (35)

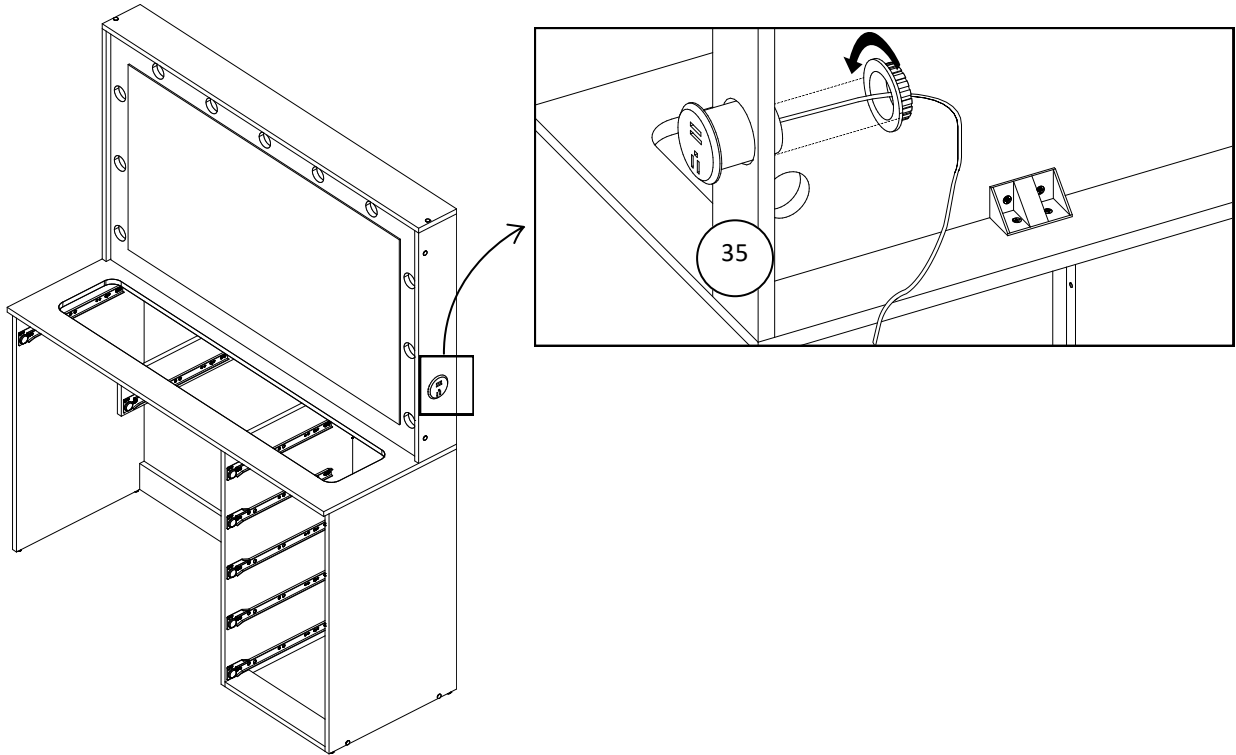

33 Install light bulbs to mirror (11)
Instala las bombillas al espejo (11)

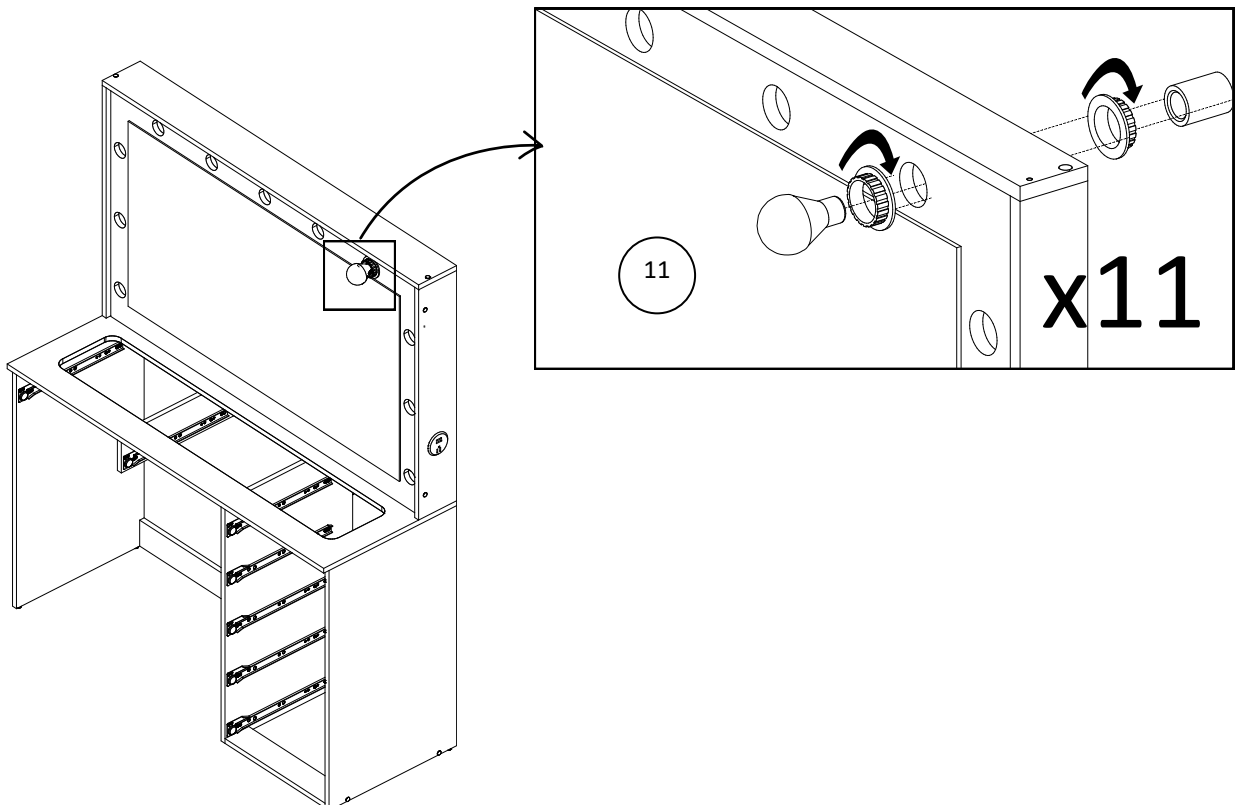

We're almost done!/¡Estamos casi listos!

33 Fix furniture to the wall
Fijar mueble a la pared

Fix the mounting bracket (V) on the back of the furniture using the flanged head screw (f)
Monte el soporte de montaje (V) en la parte posterior del mueble utilizando los tornillos cabeza flangeada (F)

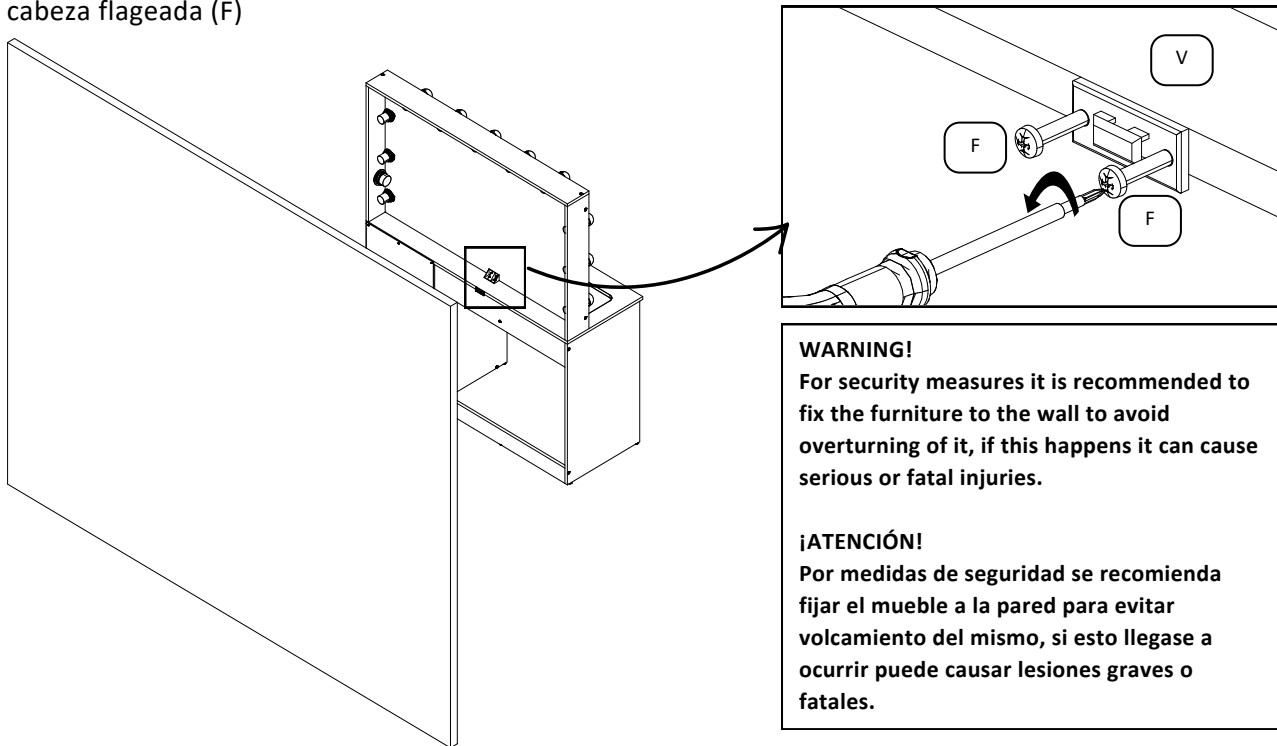

Locate a post on the wall to attach the mounting bracket (V), and place it approximately 1" below the one that is attached to the furniture. Use wall anchors (L) and screws (DE)

Localice un poste en la pared en donde fijará el soporte de montaje (V), colóquelo aproximadamente 1" por debajo del que fijó en el mueble. Utilice los anclajes de pared (L) y los tornillos (DE)

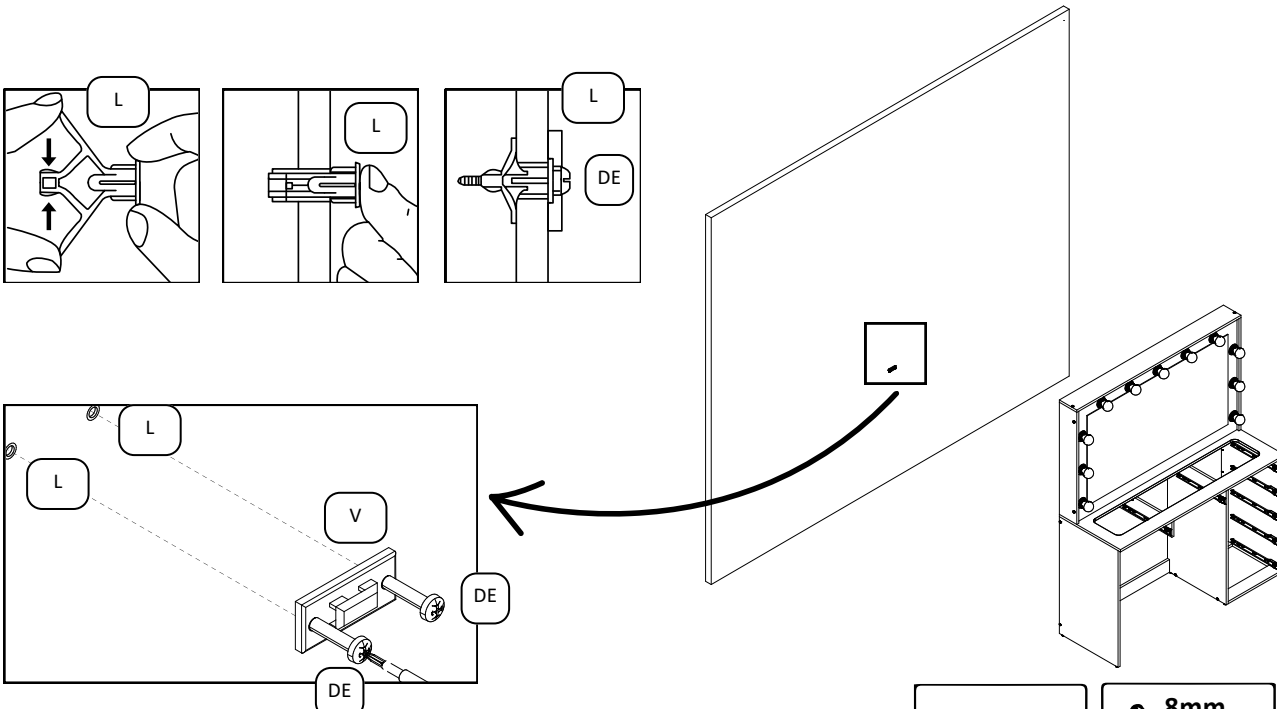

- L x2
- V x2
- F x2
- DE x2

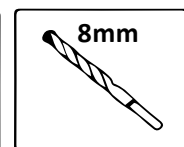
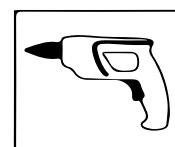

We're almost done!/¡Estamos casi listos!

33 Fix furniture to the wall
Fijar mueble a la pared

Move the furniture to its final position, taking care to align the wall mounting bracket with the cabinet mounting bracket. Pass the clamp (E) through each bracket as shown in the picture and tighten enough until it is snug.

Mueva el mueble a su posición final, cuidando de alinear el soporte de montaje de la pared con el soporte de montaje del mueble. Pase la abrazadera (E) a través de cada soporte como se muestra en la imagen y apriete lo suficiente hasta que quede ajustado.

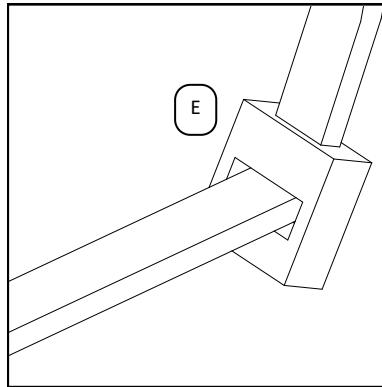

WALL

FURNITURE

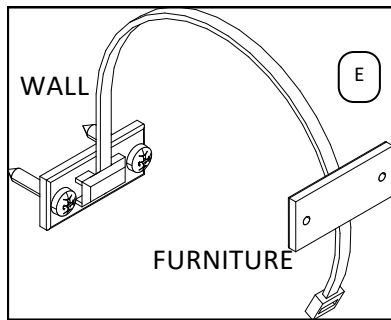

WALL

FURNITURE

WARNING!
For security measures it is recommended to fix the furniture to the wall to avoid overturning of it, if this happens it can cause serious or fatal injuries.
¡ATENCIÓN!
Por medidas de seguridad se recomienda fijar el mueble a la pared para evitar volcamiento del mismo, si esto llegase a ocurrir puede causar lesiones graves o fatales.

Make sure all parts are tight
Asegúrese que todas las piezas estén firmemente ajustadas

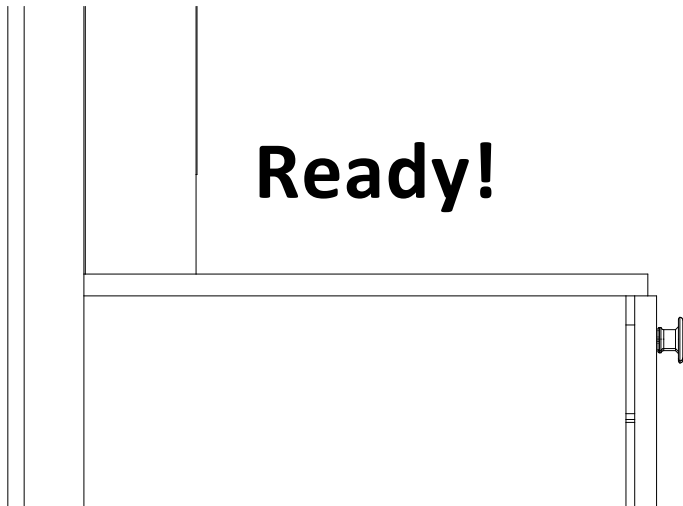

Ready!



We're almost done!/¡Estamos casi listos!

Place the drawers, dividers (AG) and glass (I) to table
Colocar los cajones, divisores (AG) y el vidrio (I) a la mesa

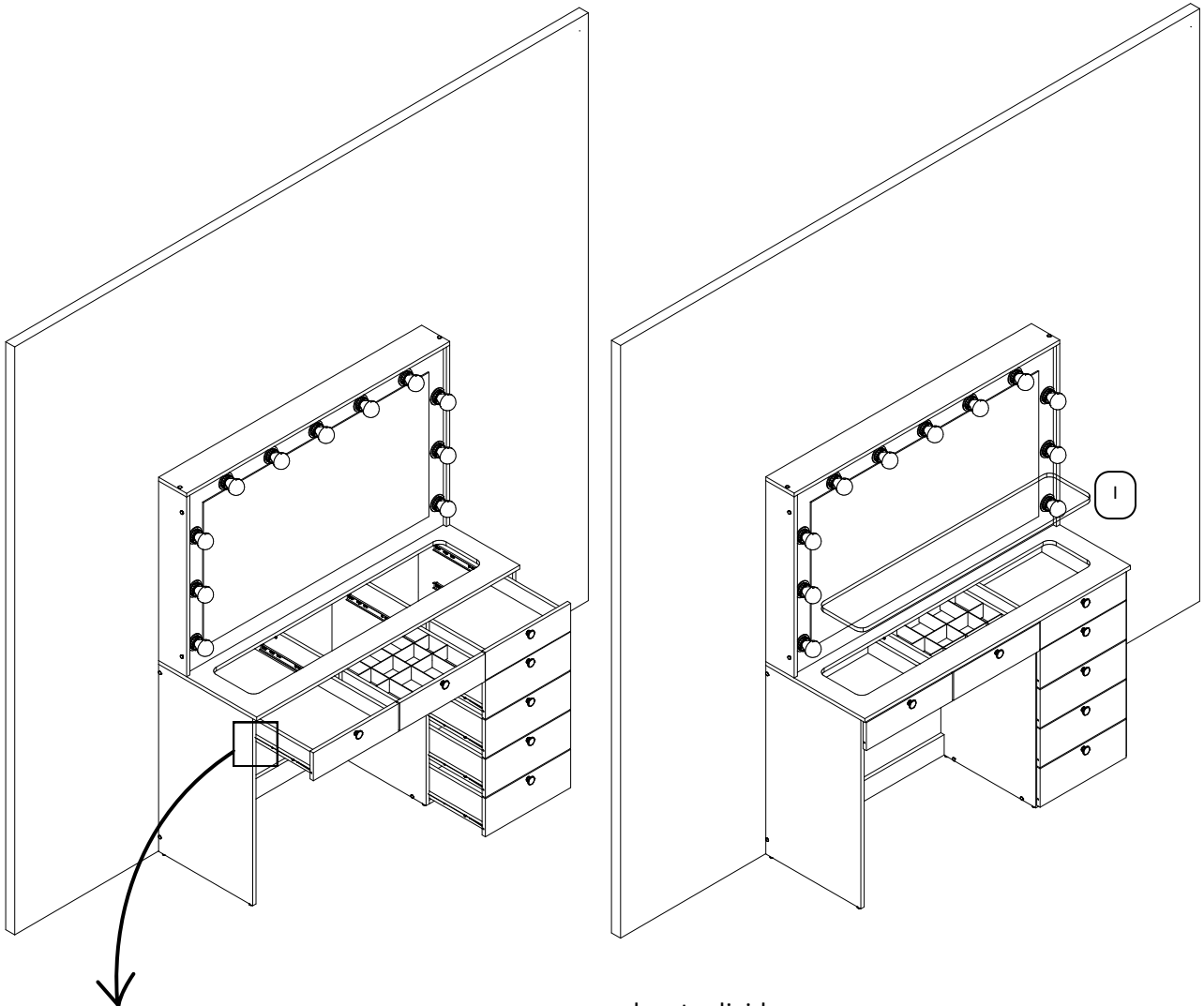

fix drawer sliders

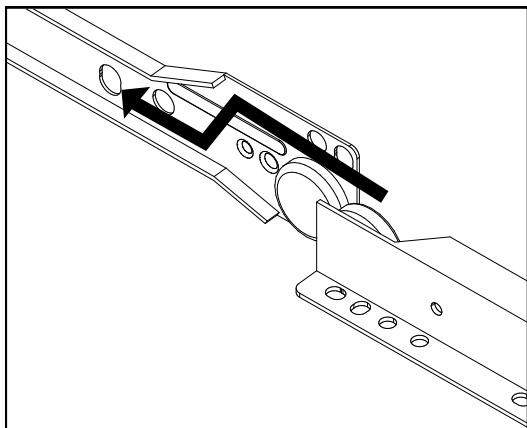

locate dividers

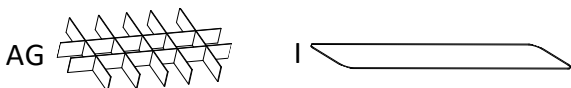
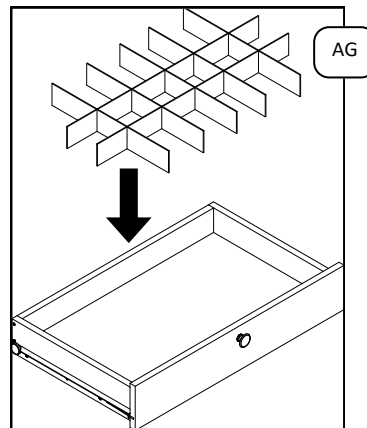

**Congratulations, you have assembled your DRESSING TABLE WITH MIRROR!!!
¡¡¡Felicitaciones, has armado tu Tocador con Espejo!!!**

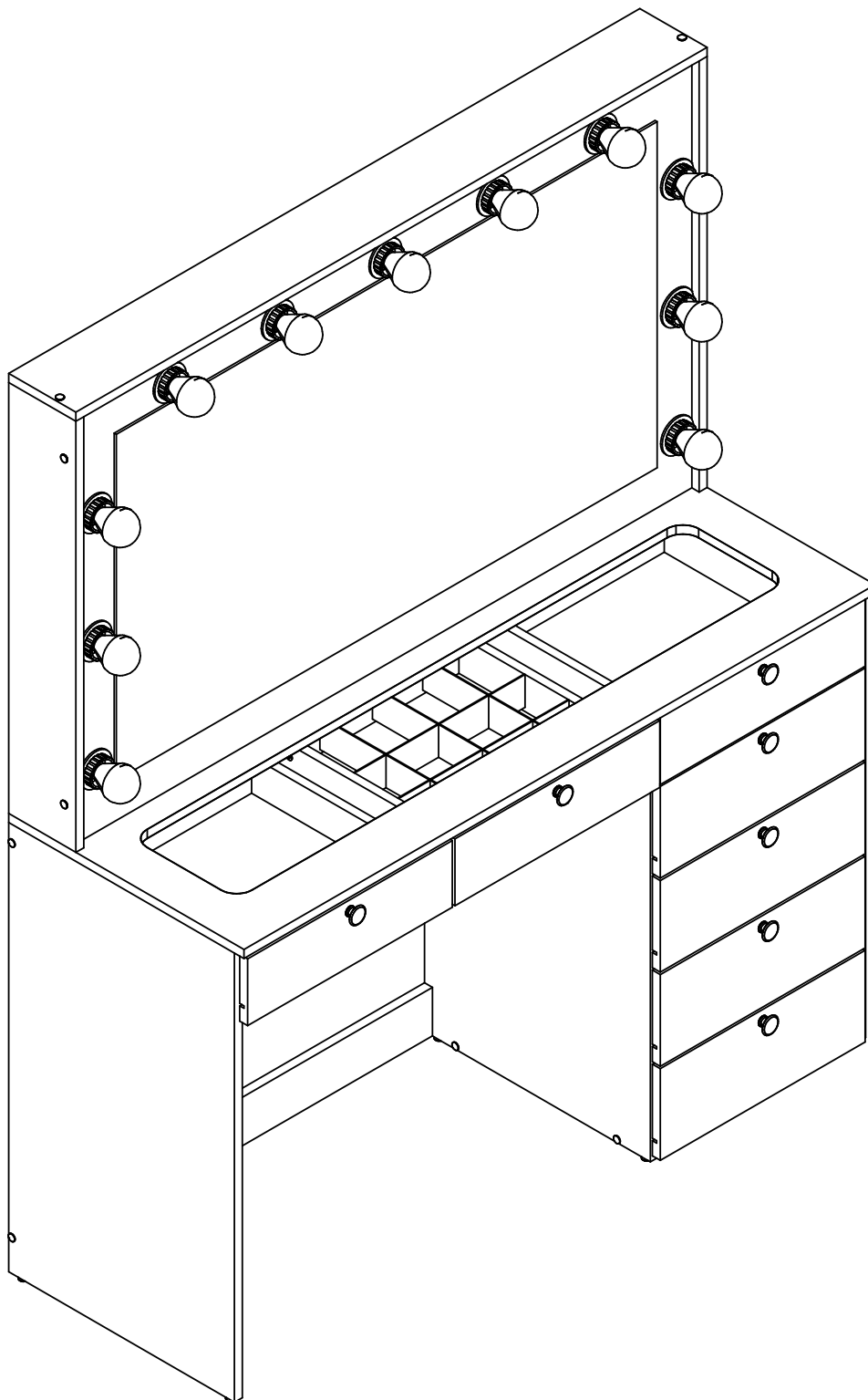

1631-L Boahaus DRESSING TABLE WITH MIRROR Warranty

6-Months Limited Warranty

1. Boahaus, LLC provides limited warranty coverage to the original purchaser of this product for a period of six months from the date of purchase against defects in materials or workmanship of Boahaus furniture components. As used in this Warranty, “defect” means imperfections in components that substantially impair the product's utility. This Warranty gives you specific legal rights, and you may also have other rights which vary from state to state.
2. There is no warranty coverage for defects or conditions that result from the failure to follow product assembly instructions, information or warnings, misuse or abuse, intentional damage, fire, flood, alteration or modification of the product, or use of the product in a manner inconsistent with its intended use, nor any condition resulting from incorrect or inadequate maintenance, cleaning, or care. There is also no warranty coverage for rented products, or any products purchased “used” or “as is”, at a distress or going-out-of-business sale, or from a liquidator.
3. As the exclusive remedy under this Warranty, Boahaus will (at its sole option) repair, replace or refund the value of any defective furniture component. Boahaus may require independent confirmation of the claimed defect and proof of purchase. Replacement parts will be warranted for only the remaining period of the original Warranty. BOAHAUS SHALL HAVE NO LIABILITY for ANY INCIDENTAL OR CONSEQUENTIAL DAMAGES OF ANY KIND and all such damages are EXCLUDED FROM THIS WARRANTY, such as loss of use, disassembly, transportation, labor, or damage to property on or near the product. Some states do not allow the exclusion or limitation of incidental or consequential damages, so the above limitation or exclusion may not apply to you.
4. This Warranty applies only to warranted defects that first arise and are transferred to subsequent owners or users of the product, and it shall be immediately void in the event the product is resold, transferred, leased, or rented to any third party or person other than the original purchaser.
5. THERE ARE NO OTHER WARRANTIES APPLICABLE TO THIS PRODUCT. Under the laws of certain states, there may be no implied warranties from Boahaus and all implied warranties, INCLUDING ANY IMPLIED WARRANTY OF MERCHANTABILITY OR FITNESS FOR A PARTICULAR PURPOSE are disclaimed where allowed by law. TO THE EXTENT ANY IMPLIED WARRANTIES ARE APPLICABLE, ANY IMPLIED WARRANTIES, INCLUDING ANY IMPLIED WARRANTY OF MERCHANTABILITY OR FITNESS FOR A PARTICULAR PURPOSE, ARE LIMITED IN DURATION TO THE DURATION OF THIS EXPRESS WARRANTY or the minimum period allowed by law, whichever is shorter. Some states do not allow limitations on how long an implied warranty lasts, so the above limitation may not apply to you.
6. For Warranty inquiries, questions about disposition, or claims, please visit our website www.boahaus.com. You can also contact Boahaus at **+1 281-809-4043** or email at contact@boahaus.com. Boahaus may require Warranty claims to be submitted in writing to:

Boahaus LLC.
1250-1252
Ave. Franklin Delano Roosevelt,
San Juan, PR 00926.

Please include your sales receipt or other proof of purchase and a specific description of the product defect.

Garantía de Tocador con Espejo 1631-L Boahaus

Garantía limitada de 6 meses

1. Boahaus, LLC proporciona cobertura de garantía limitada al comprador original de este producto por un período de 6 meses a partir de la fecha de compra contra defectos en materiales o mano de obra de componentes de muebles de Boahaus. Como se especifica en esta Garantía, "defecto" significa imperfecciones en componentes que perjudican sustancialmente la utilidad del producto. Esta Garantía le otorga derechos legales específicos y también puede tener otros derechos que varían de un estado a otro.
2. No hay cobertura de garantía por defectos o condiciones que resulten del incumplimiento de las instrucciones del producto, o advertencias, uso indebido o abuso, daño intencional, incendio, inundación, alteración o modificación del producto o uso del producto de manera inconsistente con su uso previsto, o cualquier condición resultante de mantenimiento incorrecto o inadecuado, limpieza o cuidado. Tampoco hay cobertura de garantía para productos alquilados o cualquier producto comprado "usado" o "tal cual", en una venta de emergencia o de salida de la empresa, o de un liquidador.
3. Boahaus puede requerir una confirmación independiente del defecto reclamado y un comprobante de compra. Las piezas de repuesto estarán garantizadas durante el período restante de la garantía original. BOAHAUS NO TENDRÁ NINGUNA RESPONSABILIDAD POR CUALQUIER DAÑO INCIDENTAL y todos estos daños ESTÁN EXCLUIDOS DE ESTA GARANTÍA, tales como pérdida de uso, desmontaje, transporte, mano de obra o daños a la propiedad en o cerca del producto. Algunos estados no permiten la exclusión o limitación de daños incidentales o consecuentes, por lo que la limitación o exclusión anterior puede no aplicarse a usted.
4. Esta Garantía se aplica únicamente a los defectos garantizados que surgen y se informan a Boahaus dentro del período de cobertura de la garantía. La garantía no puede ser transferida a los propietarios o usuarios posteriores del producto, y será inmediatamente nula en caso de que el producto sea revendido, transferido, arrendado o alquilado a cualquier tercero o persona que no sea el comprador original.
5. NO HAY OTRAS GARANTÍAS APLICABLES A ESTE PRODUCTO. Bajo las leyes de ciertos estados, no puede haber garantías implícitas de Boahaus y todas las garantías implícitas, INCLUYENDO CUALQUIER GARANTÍA IMPLÍCITA DE COMERCIALIZACIÓN O ADECUACIÓN PARA UN PROPÓSITO PARTICULAR, están exoneradas cuando permitido por la ley. TODAS LAS GARANTÍAS IMPLÍCITAS SON APLICABLES, LAS GARANTÍAS IMPLÍCITAS, INCLUIDAS CUALQUIER GARANTÍA IMPLÍCITA DE COMERCIALIZACIÓN O ADECUACIÓN PARA UN PROPÓSITO PARTICULAR, ESTÁN LIMITADAS EN DURACIÓN A LA DURACIÓN DE ESTA GARANTÍA EXPRESA o el período mínimo permitido por la ley, cualquiera que sea más corto. Algunos estados no permiten limitaciones sobre la duración de una garantía implícita, por lo que es posible que la limitación anterior no se aplique a usted.
6. Para consultas sobre la garantía, preguntas sobre la disposición o reclamaciones, visite nuestro sitio web www.boahaus.com. También puede ponerse en contacto con Boahaus en +1 281-809-4043 o por correo electrónico en contact@boahaus.com. Boahaus puede requerir que los reclamos de garantía sean presentados por escrito a:

Boahaus LLC.
1250-1252
Ave. Franklin Delano Roosevelt,
San Juan, PR 00926.

Please include your sales receipt or other proof of purchase and a specific description of the product defect.