

# Assembly Instructions

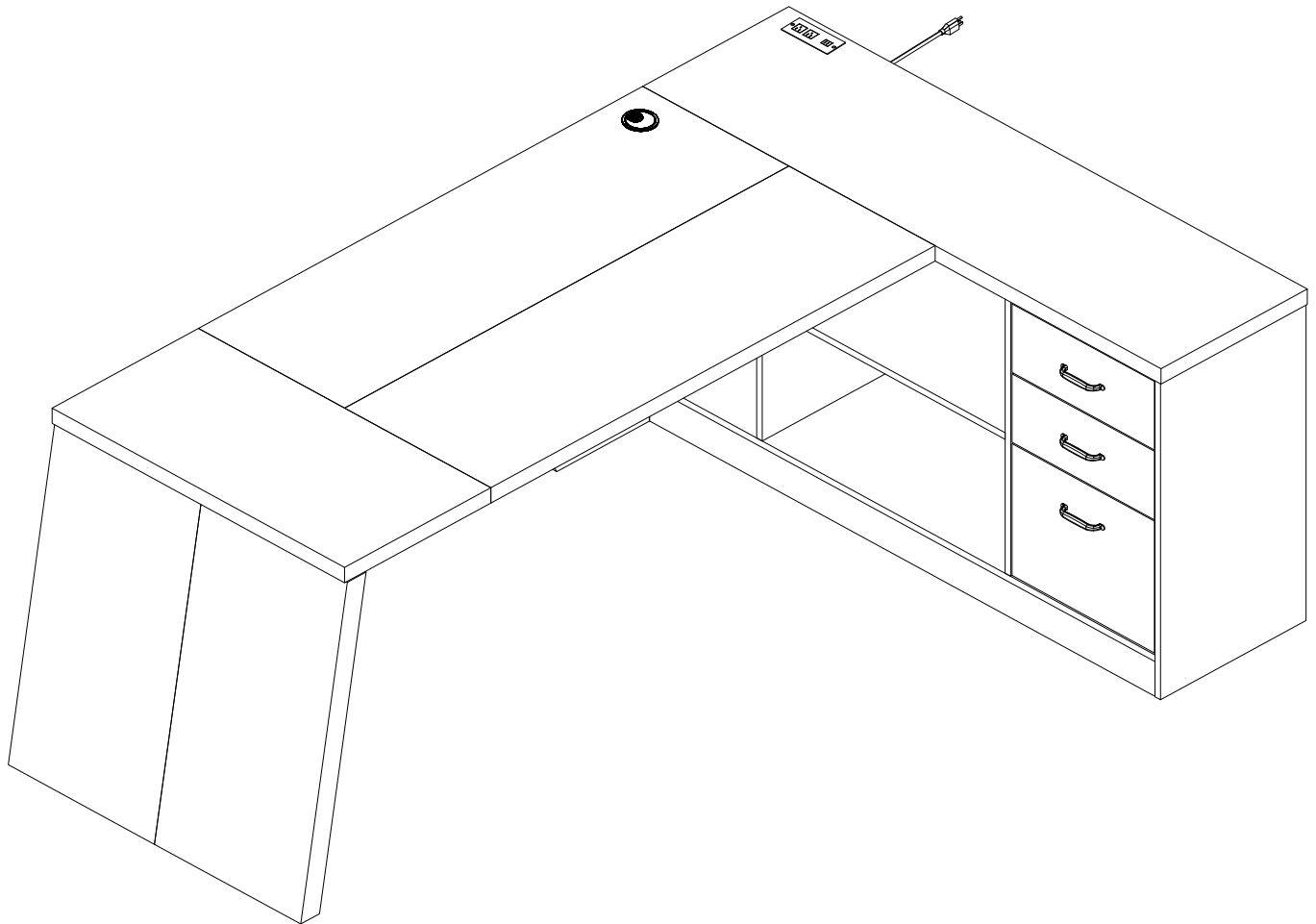

Model No. ZL-ZY0018/ZY0074/ZY0075

# Contact Us

## We're here to help you.



Your satisfaction is our top priority. If you encounter any issues with this product, such as missing or damaged parts, we're here to help. Please retain the original packaging and take photos of the packaging and the product, then contact us as soon as possible.

**Email: [support@epecoya.com](mailto:support@epecoya.com)**

### Warm Tips

1. Carefully read these instructions and keep them for future reference.
2. Check the parts list and confirm everything's there before starting assembly.
3. When assembling, put all parts on a soft, smooth surface like a carpet to avoid scratches.
4. Don't fully tighten screws until all parts are confirmed in place to avoid misalignment.

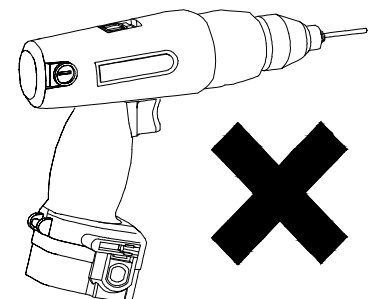
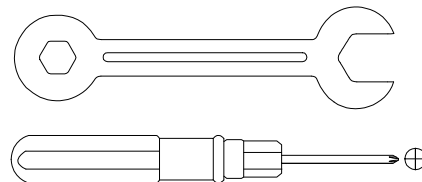
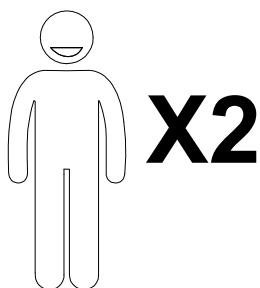

We recommend using hand tools for assembly.

If an electric screwdriver is used, reduce power and torque to avoid damage to the product.

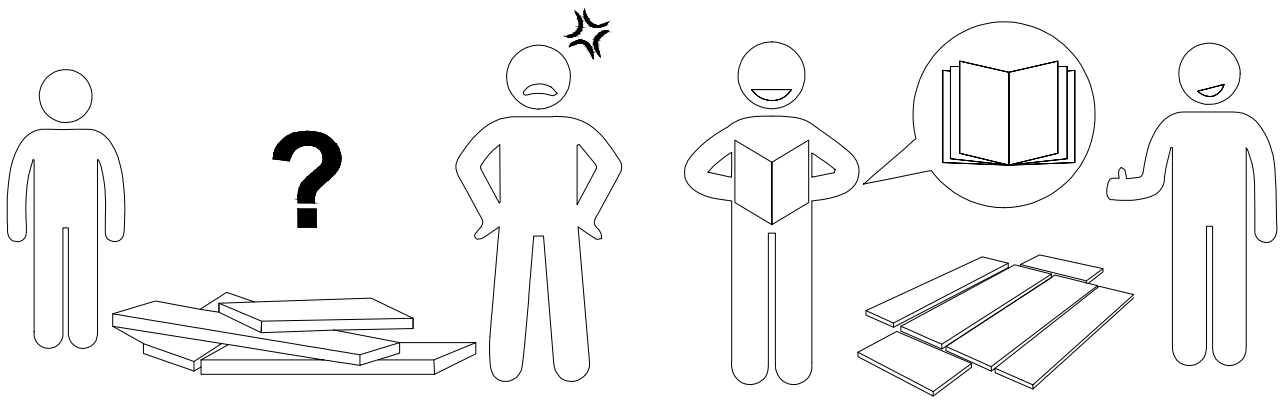

---

## AVOID SCRATCHES

In order to avoid scratching, this furniture should be assembled on a soft surface, such as a rug.

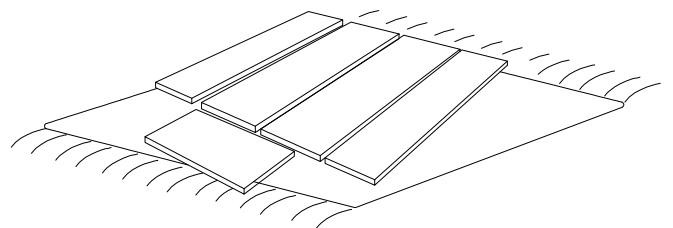
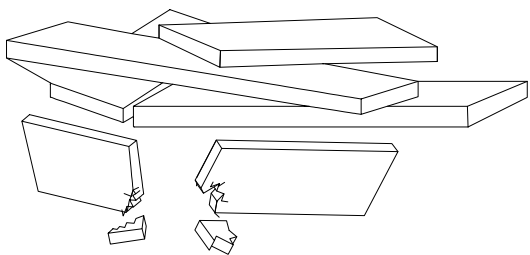

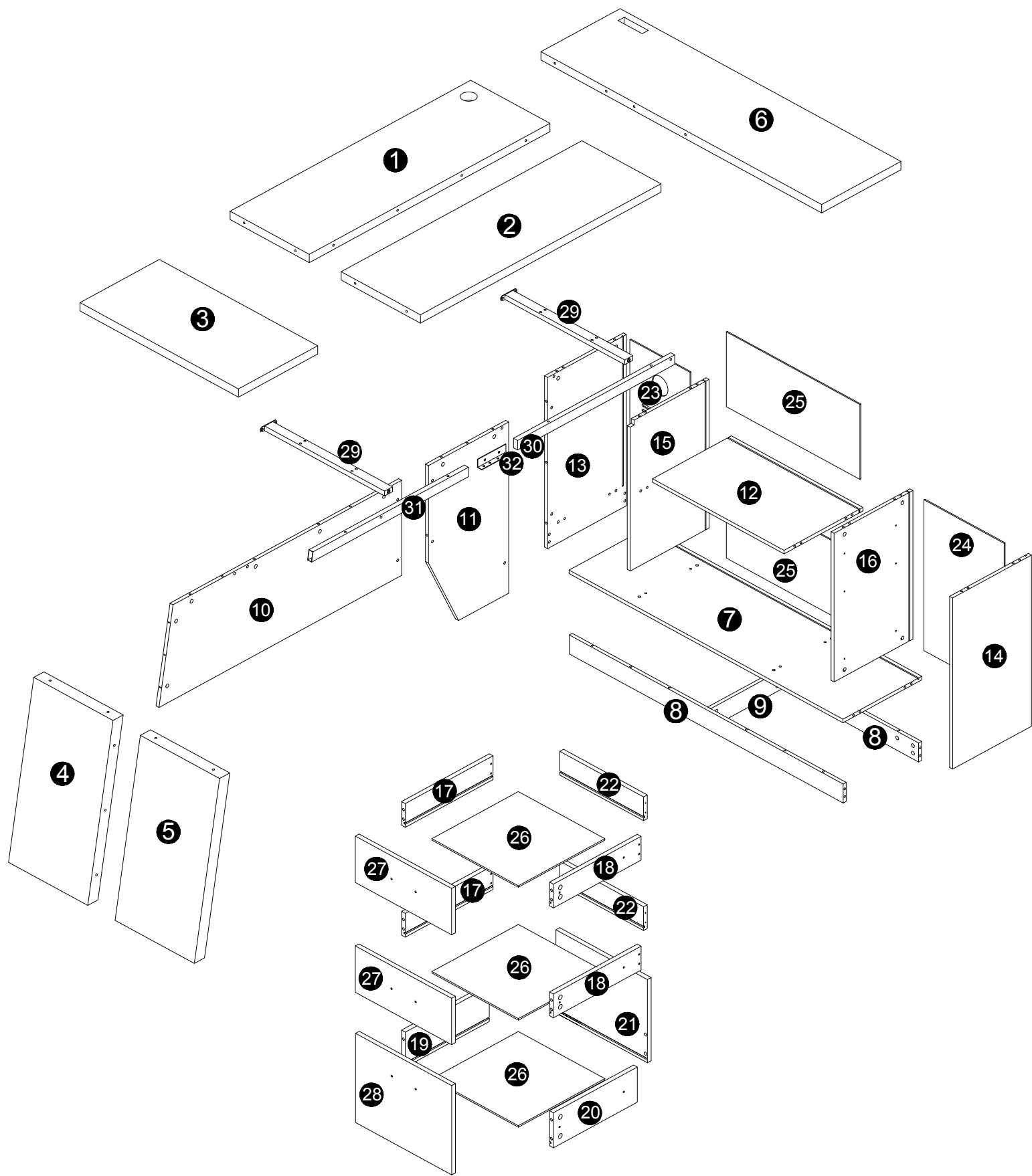

**⚠ Caution**

Make sure all parts are included. Most board parts are labeled or stamped on the raw edge. Contact us for a free replacement if you encounter any damaged or missing parts.

# Parts List

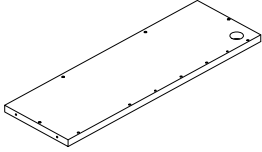
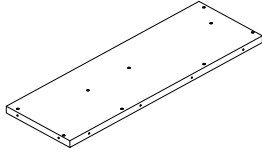
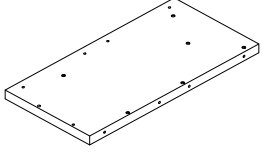
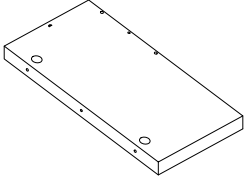
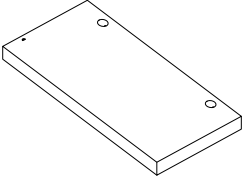
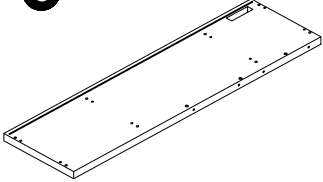
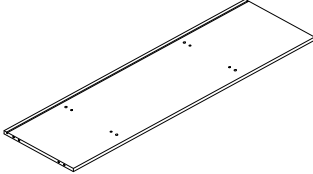
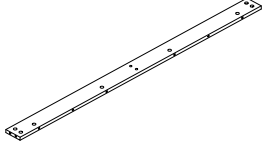
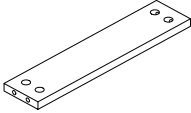
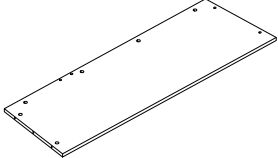
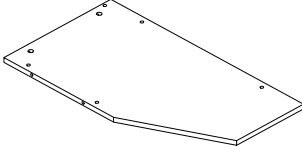
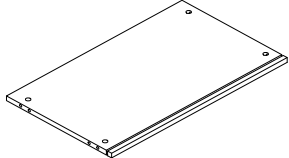
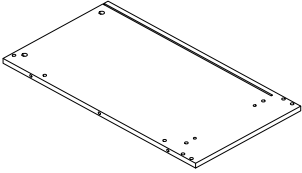
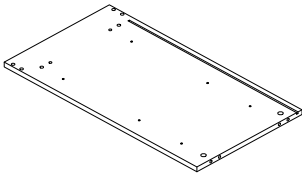
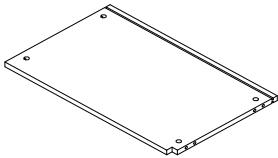
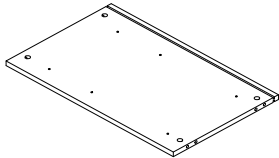
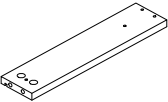
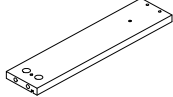
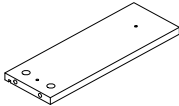
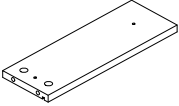
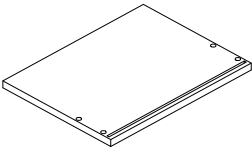
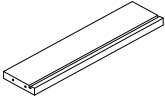
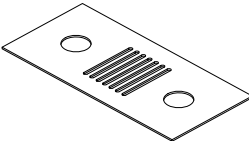
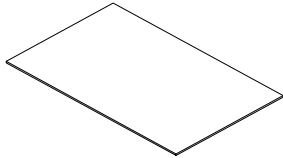
<p><b>1</b></p>  <p>1pc</p>	<p><b>2</b></p>  <p>1pc</p>	<p><b>3</b></p>  <p>1pc</p>	<p><b>4</b></p>  <p>1pc</p>
<p><b>5</b></p>  <p>1pc</p>	<p><b>6</b></p>  <p>1pc</p>	<p><b>7</b></p>  <p>1pc</p>	<p><b>8</b></p>  <p>2 pcs</p>
<p><b>9</b></p>  <p>1pc</p>	<p><b>10</b></p>  <p>1pc</p>	<p><b>11</b></p>  <p>1pc</p>	<p><b>12</b></p>  <p>1pc</p>
<p><b>13</b></p>  <p>1pc</p>	<p><b>14</b></p>  <p>1pc</p>	<p><b>15</b></p>  <p>1pc</p>	<p><b>16</b></p>  <p>1pc</p>
<p><b>17</b></p>  <p>2 pcs</p>	<p><b>18</b></p>  <p>2 pcs</p>	<p><b>19</b></p>  <p>1pc</p>	<p><b>20</b></p>  <p>1pc</p>
<p><b>21</b></p>  <p>1pc</p>	<p><b>22</b></p>  <p>2 pcs</p>	<p><b>23</b></p>  <p>1pc</p>	<p><b>24</b></p>  <p>1pc</p>

# Parts List

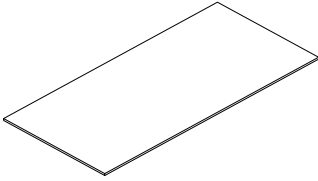
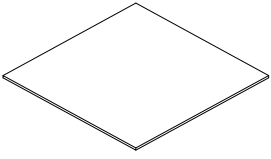
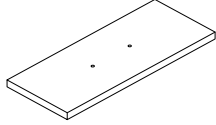
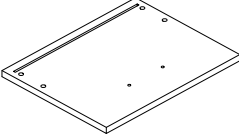
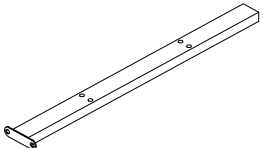
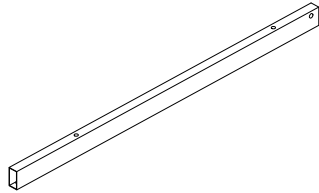
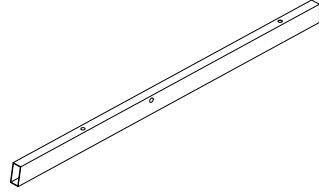
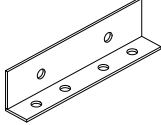

<p>25</p>  <p>2 pcs</p>	<p>26</p>  <p>3 pcs</p>	<p>27</p>  <p>2 pcs</p>	<p>28</p>  <p>1 pc</p>
<p>29</p>  <p>2 pcs</p>	<p>30</p>  <p>1 pc</p>	<p>31</p>  <p>1 pc</p>	<p>32</p>  <p>1 pc</p>



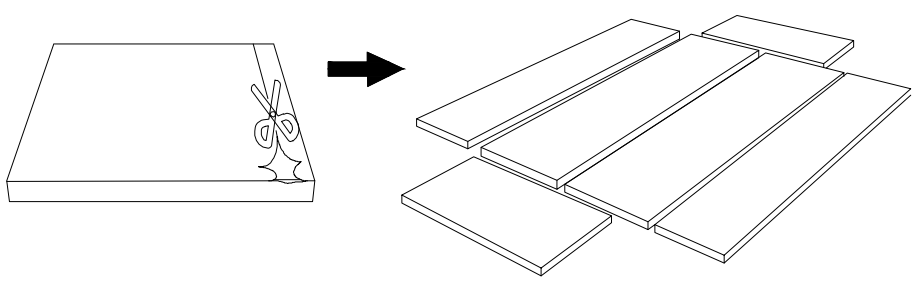

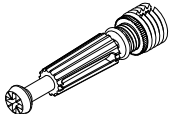
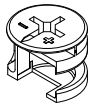
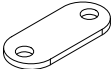
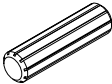

**Before installation, please check if you have received the A and B packages, and check if the parts are complete.**



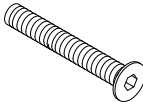

ZL-ZY0018-A ZL-ZY0074-A ZL-ZY0075-A						ZL-ZY0018-B ZL-ZY0074-B ZL-ZY0075-B					
3	1 pc	4	1 pc	5	1 pc	1	1 pc	2	1 pc		
11	1 pc	12	1 pc	13	1 pc	6	1 pc	7	1 pc		
14	1 pc	15	1 pc	16	1 pc	8	2 pcs	9	1 pc		
21	1 pc	23	1 pc	24	1 pc	10	1 pc	17	2 pcs		
25	2 pcs	26	3 pcs	28	1 pc	18	2 pcs	19	1 pc		
29	2 pcs	30	1 pc	31	1 pc	20	1 pc	22	2 pcs		
32	1 pc					27	2 pcs				





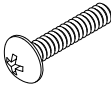
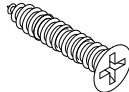

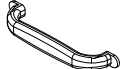

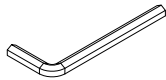

# Hardware List

A	B	C	D	E	F
					
Ø6x40mm	Ø15x12mm	L56xW24xH2mm	Ø8x30mm	Ø6x16mm	Ø6x35mm
60+1 pcs	60+1 pcs	8 pcs	50+1 pcs	18 pcs	10 pcs

G	H	I	J	K	L
					
Ø6x55mm	Ø6x10mm	Ø8x90mm	M 8	M 8	M 14
4 pcs	12 pcs	2 pcs	4 pcs	4 pcs	1 pc

M	N	O	P	Q	R
					
Ø4x20mm	Ø3.5x35mm	Ø3.5x14mm		20x20x130mm	Ø15x2mm
6 pcs	12+1 pcs	34+4 pcs	3 sets	3 pcs	8 pcs

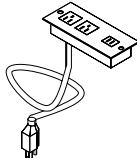
S	T	U	V	W	X
					
Ø25x2mm	M3	365x35x16mm	318x25x22mm		
4 pcs	1pc	2 pcs	2 pcs	2 pcs	1pc

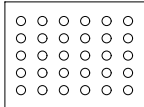
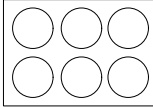
Y	Z	A1	A2	A3	
					
Ø60					
1pc	1pc	1pc	50 pcs	4 pcs	

## Installation of Cams and Pins

Step 1-2: Align the plastic part with the mounting hole and press it in. If you can't press it in, loosen the screw counter clockwise or completely remove the screw from the plastic part and try again.  
Step 3-4: After pressing the plastic part into place, use a screwdriver to tighten the screw clockwise.

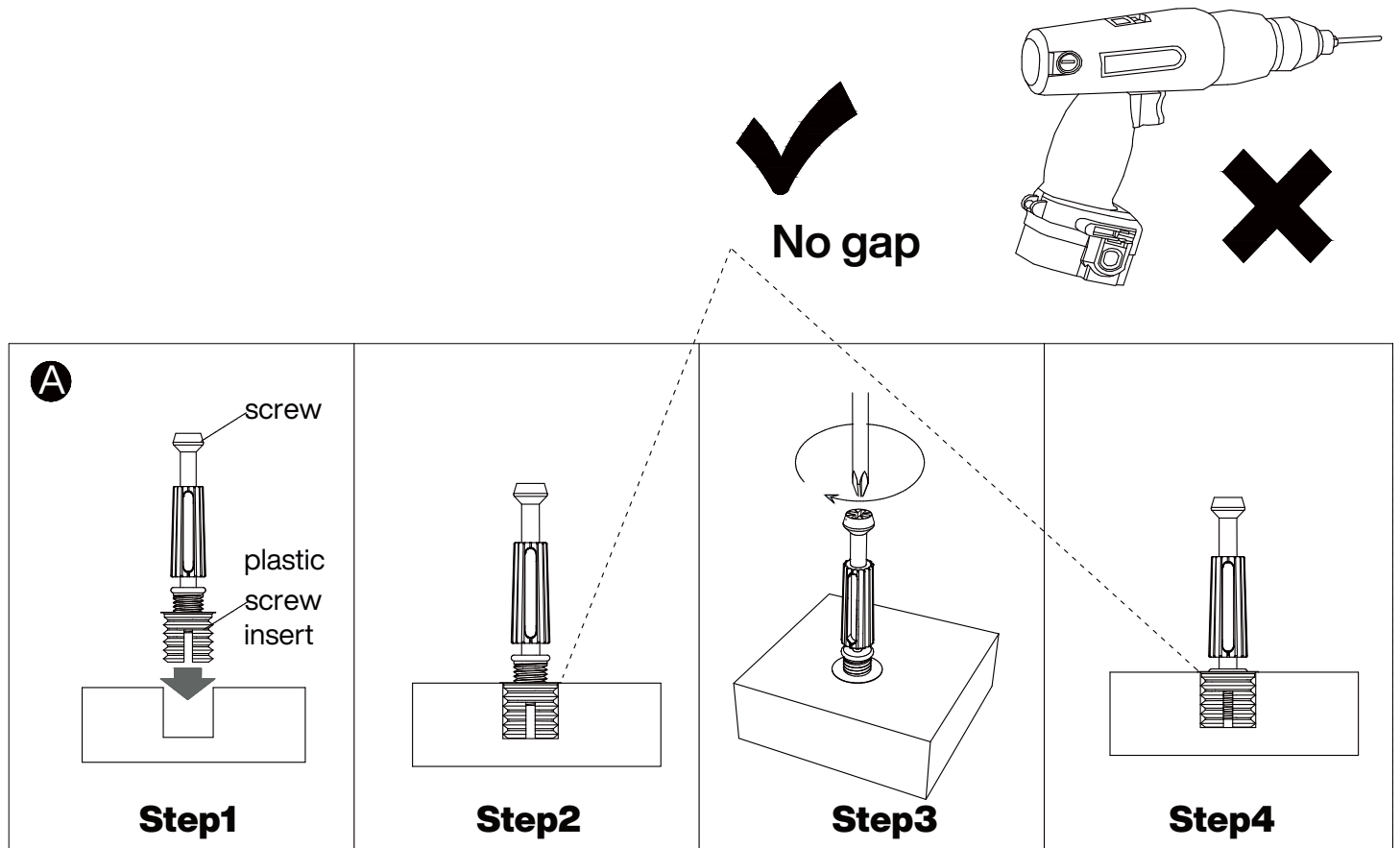

Screw the pin into the hole. Set the cams correctly by aligning the head of the cams with the lock pins. Lock the cam by turning the cam head with a screwdriver until it is tightened. Please do not use an electric screwdriver to assemble the unit.

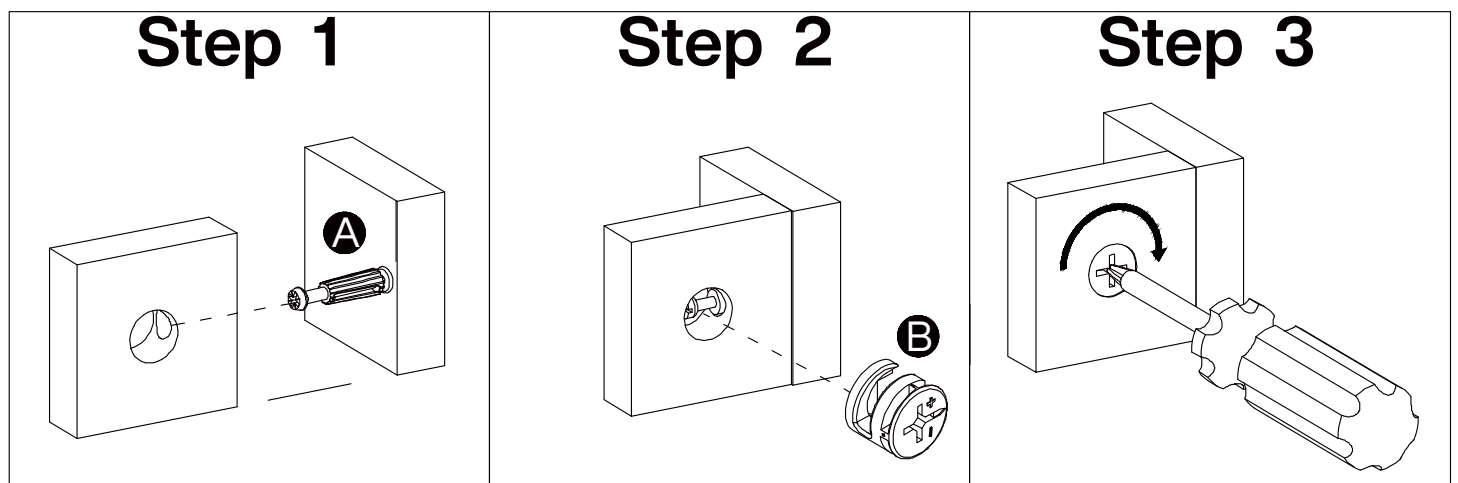

Please split component "P" into "P1" and "P2" before assembling the slide and then proceed to the next step of assembly

### Step 1

Pull apart component "P" to each side, and then gently push up the lever of component "P2"

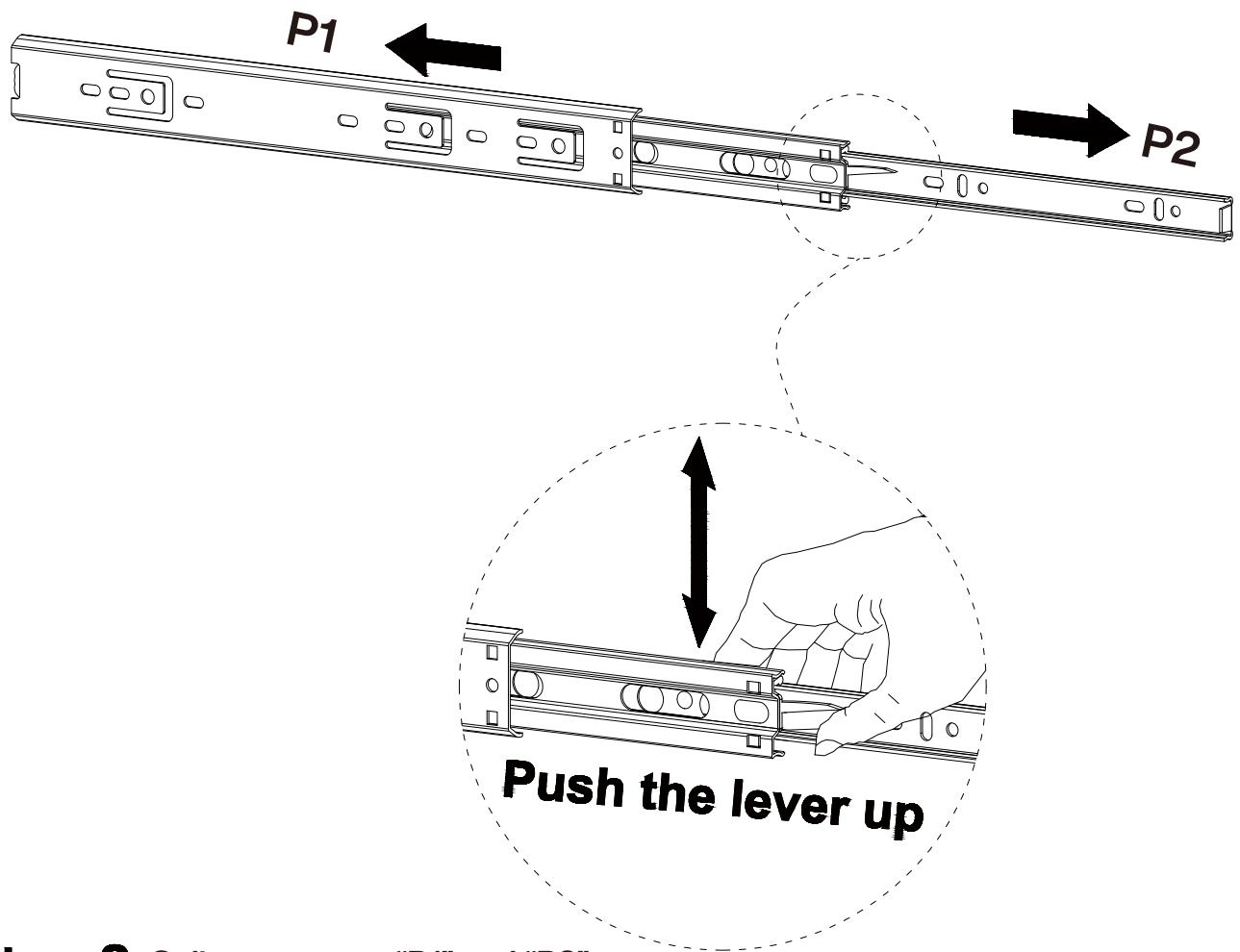

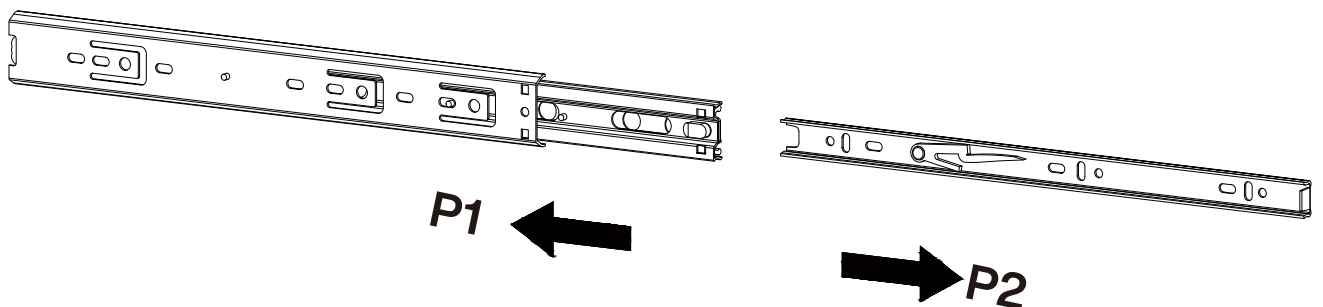

### Step 2 Split component "P1" and "P2"

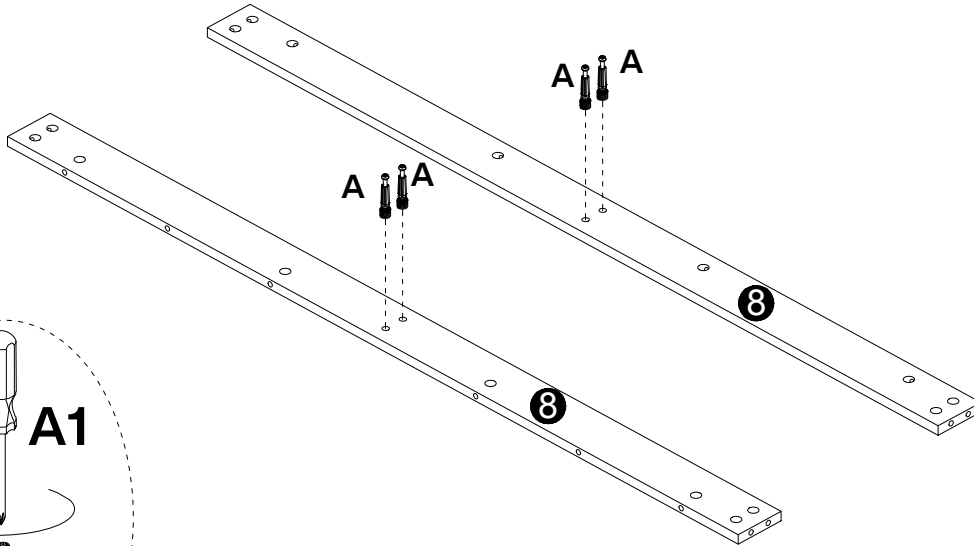

1



<b>A</b>

Ø6×40mm 4 pcs
<b>A1</b>

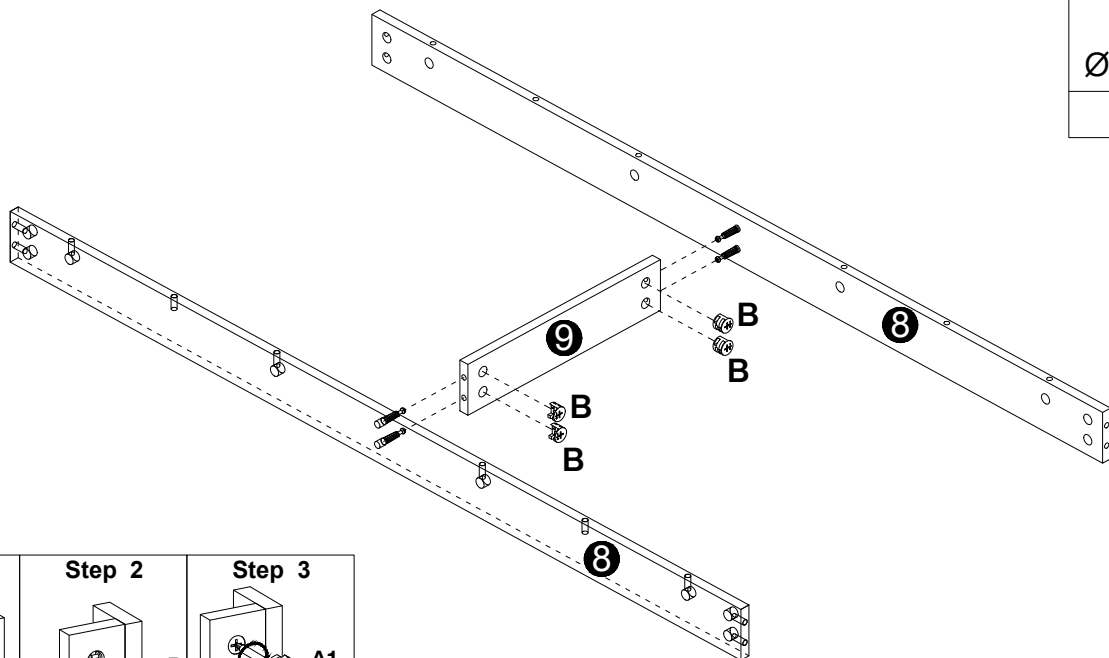
1pc

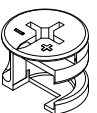
2

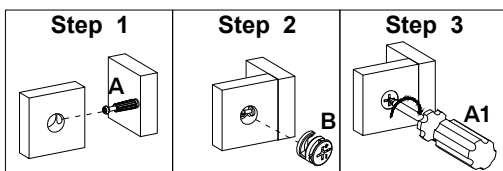

<b>B</b>

Ø15×12mm 4 pcs

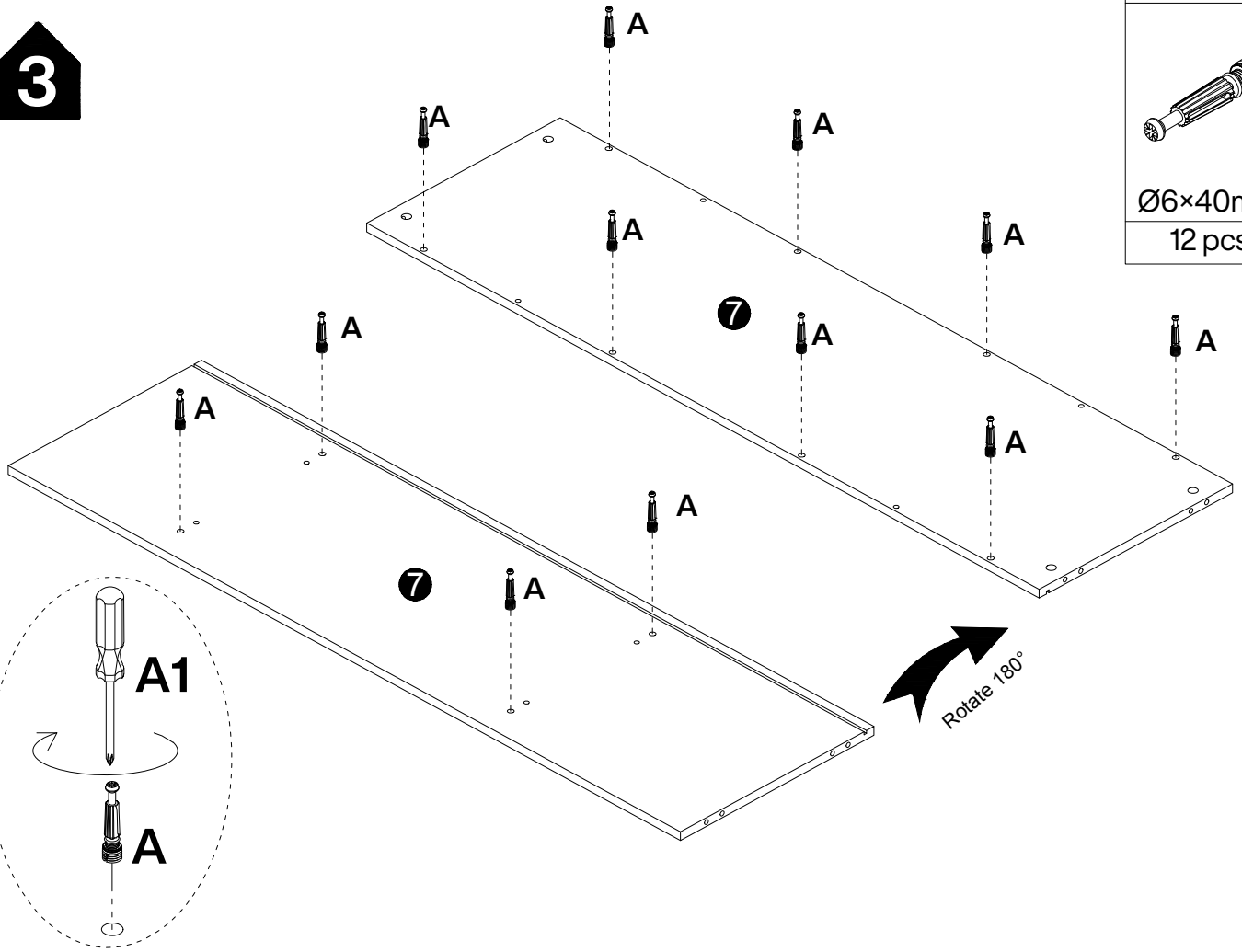

3



A

Ø6×40mm
12 pcs

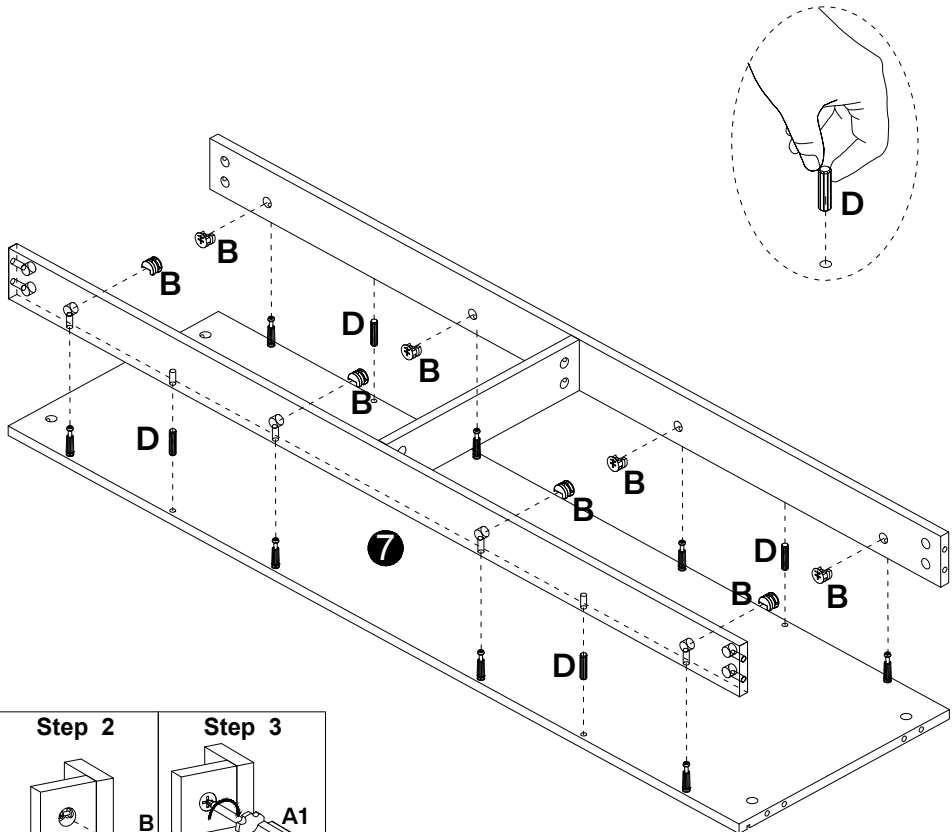
4

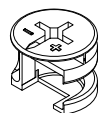
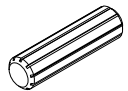

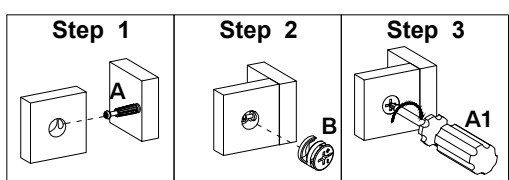
B

Ø15×12mm
8 pcs
D

Ø8×30mm
4 pcs

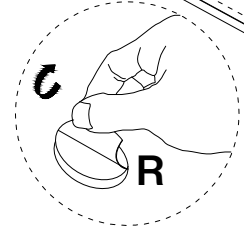
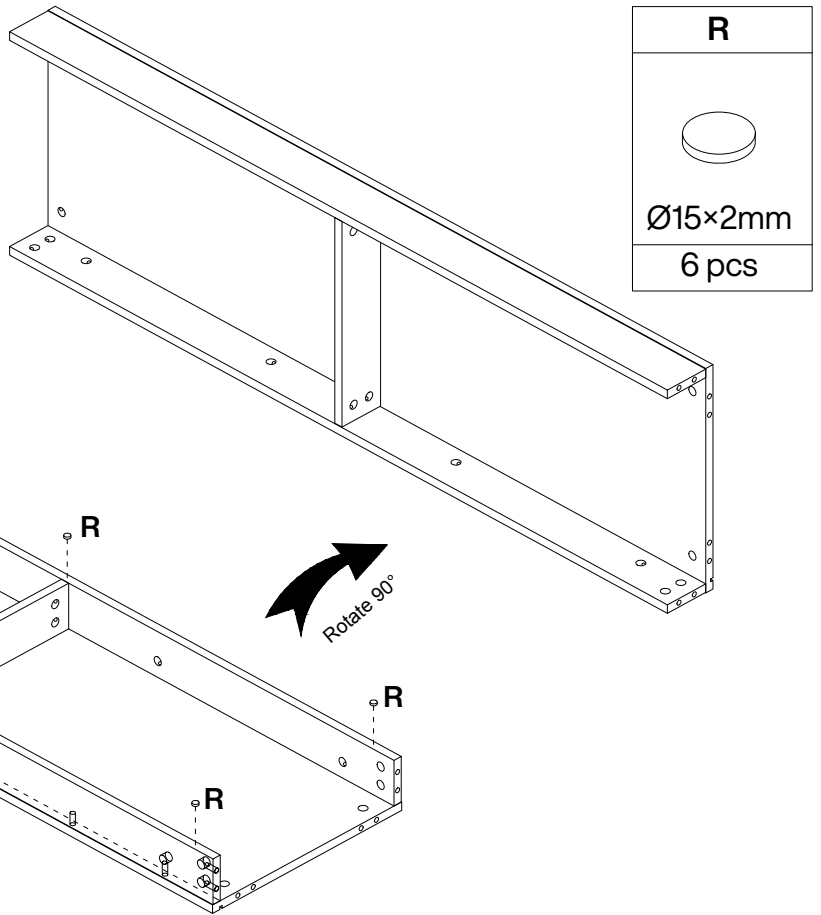



**5**

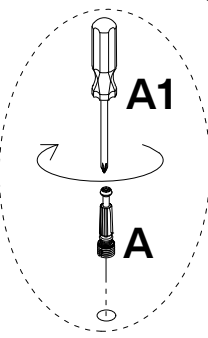
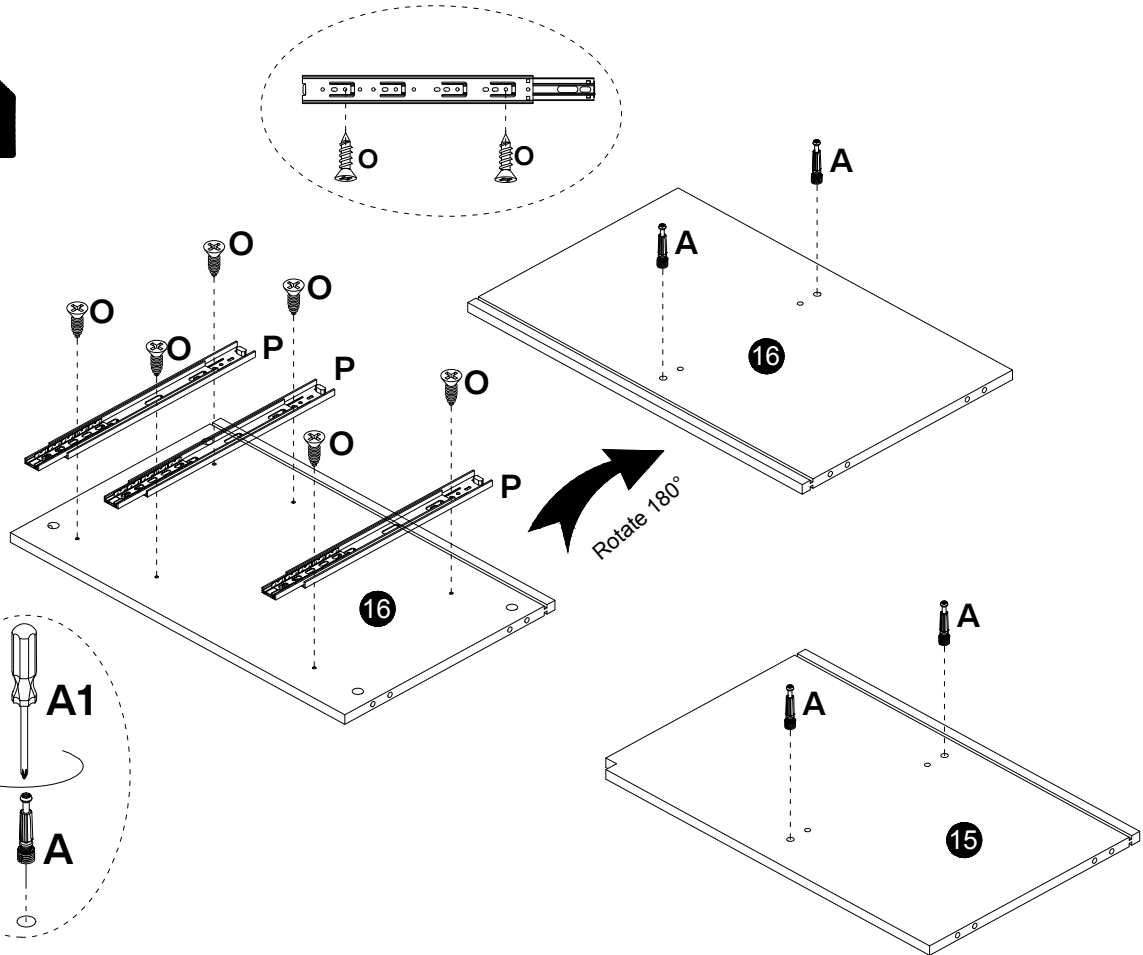

To prevent the table from scratching the floor, please peel off the tape on the #R and tape them to the corners of the table before use.

**6**

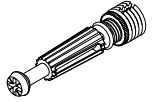
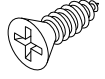

<b>A</b>

Ø6×40mm
4 pcs
<b>O</b>

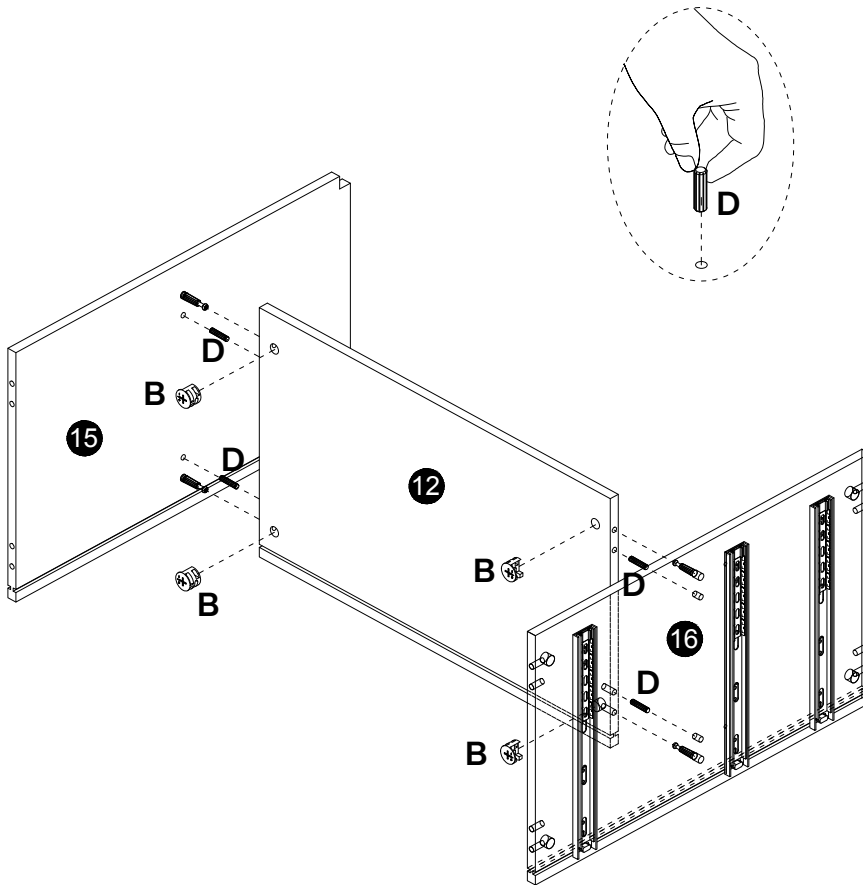
Ø3.5×14mm
6 pcs
<b>P</b>

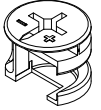
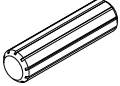
L350mm
3 sets

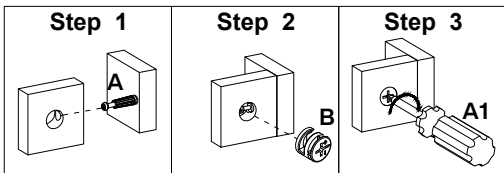
7



<b>B</b>

Ø15×12mm 4 pcs
<b>D</b>

Ø8×30mm 4 pcs

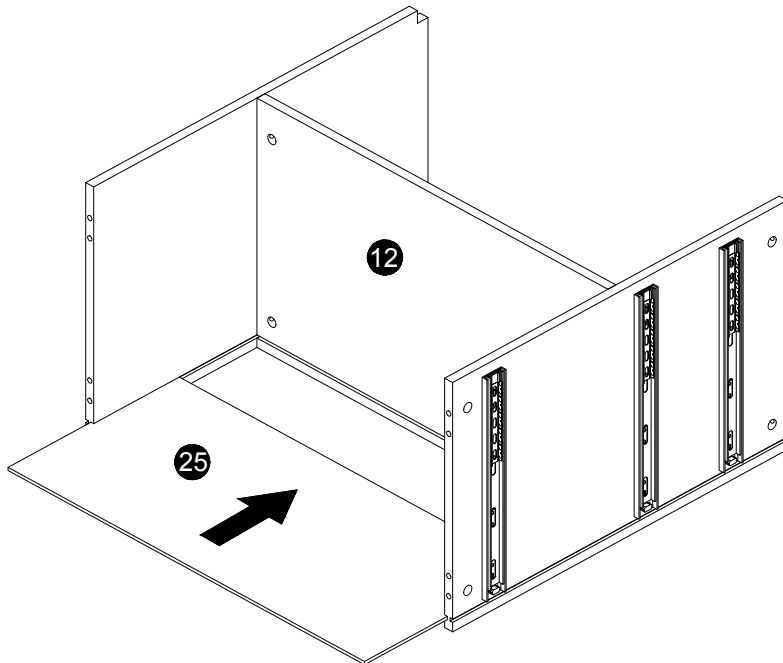

8

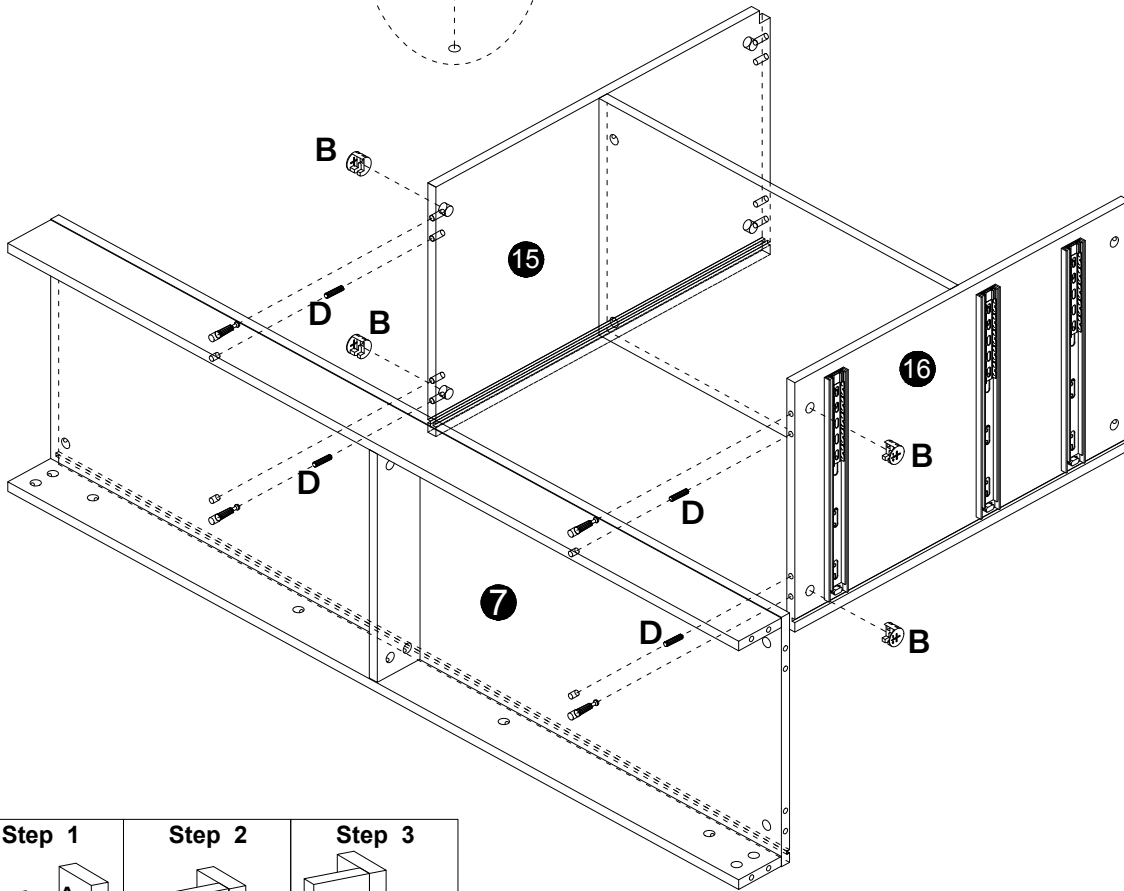
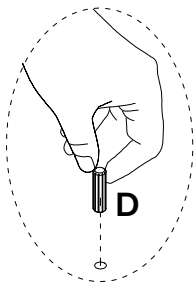

9



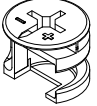
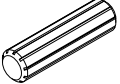

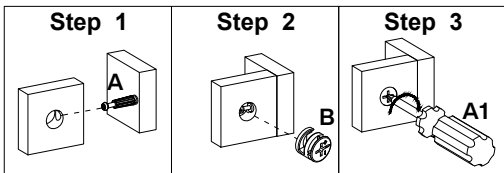
<b>B</b>

Ø15×12mm
4 pcs
<b>D</b>

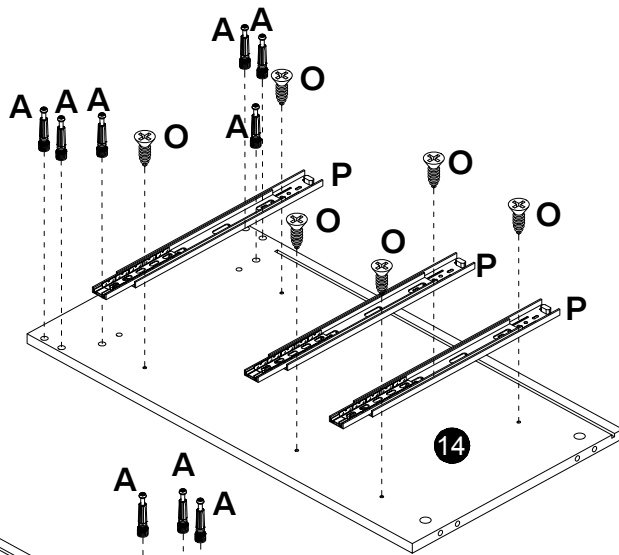
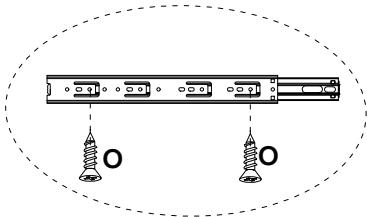
Ø8×30mm
4 pcs

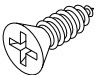

10

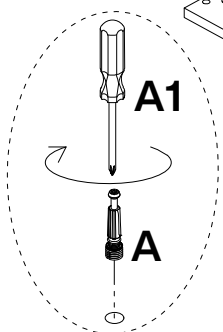

<b>A</b>

Ø6×40mm
12 pcs
<b>O</b>

Ø3.5×14mm
6 pcs
<b>P</b>

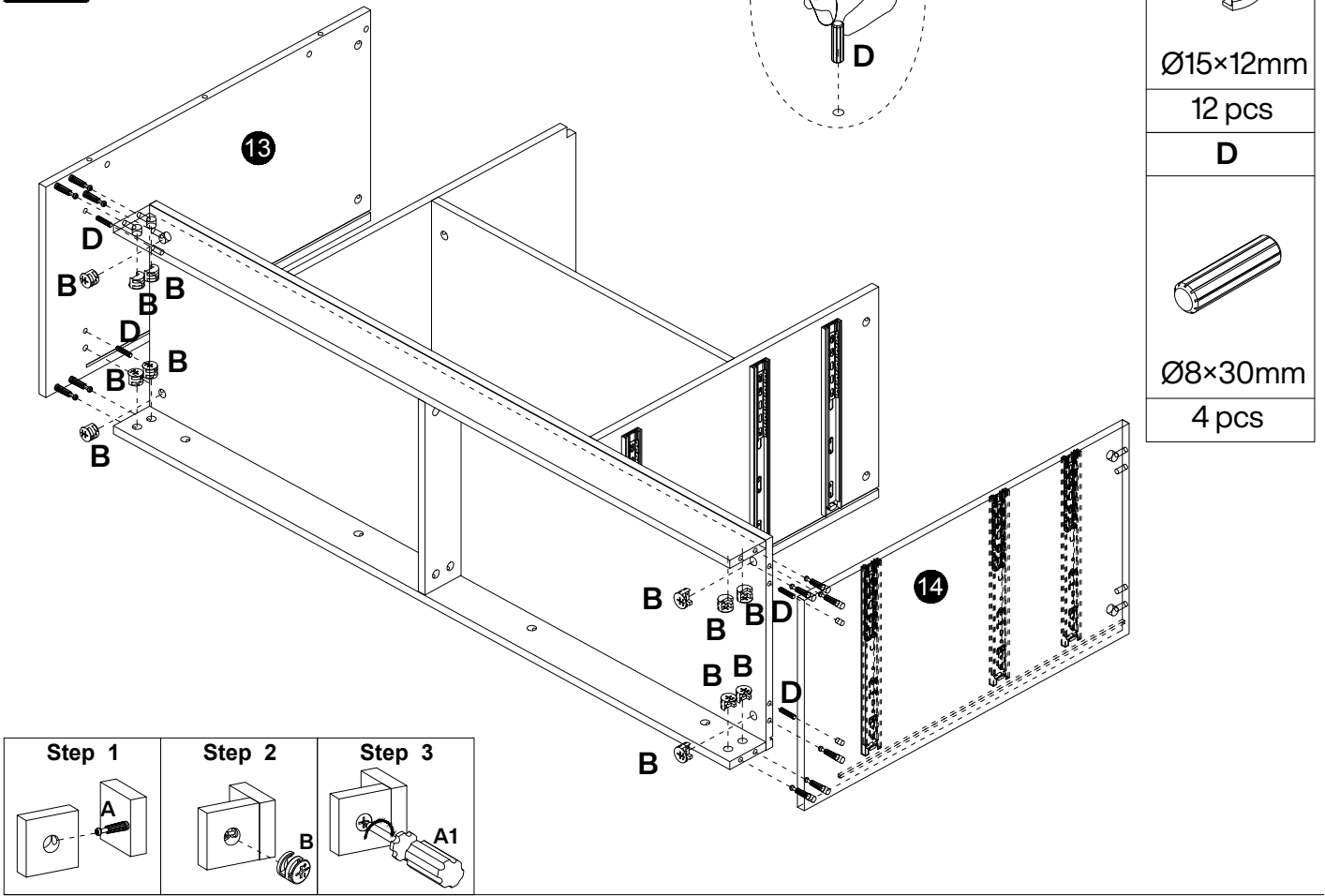
L350mm
3 sets

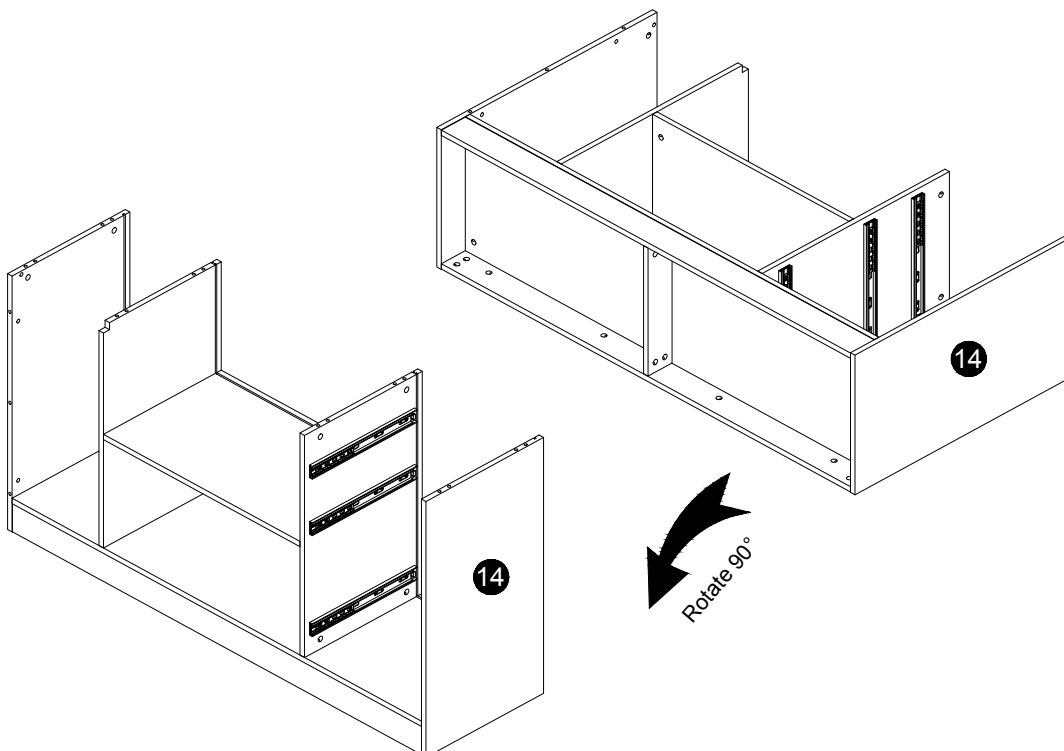

11



12



13

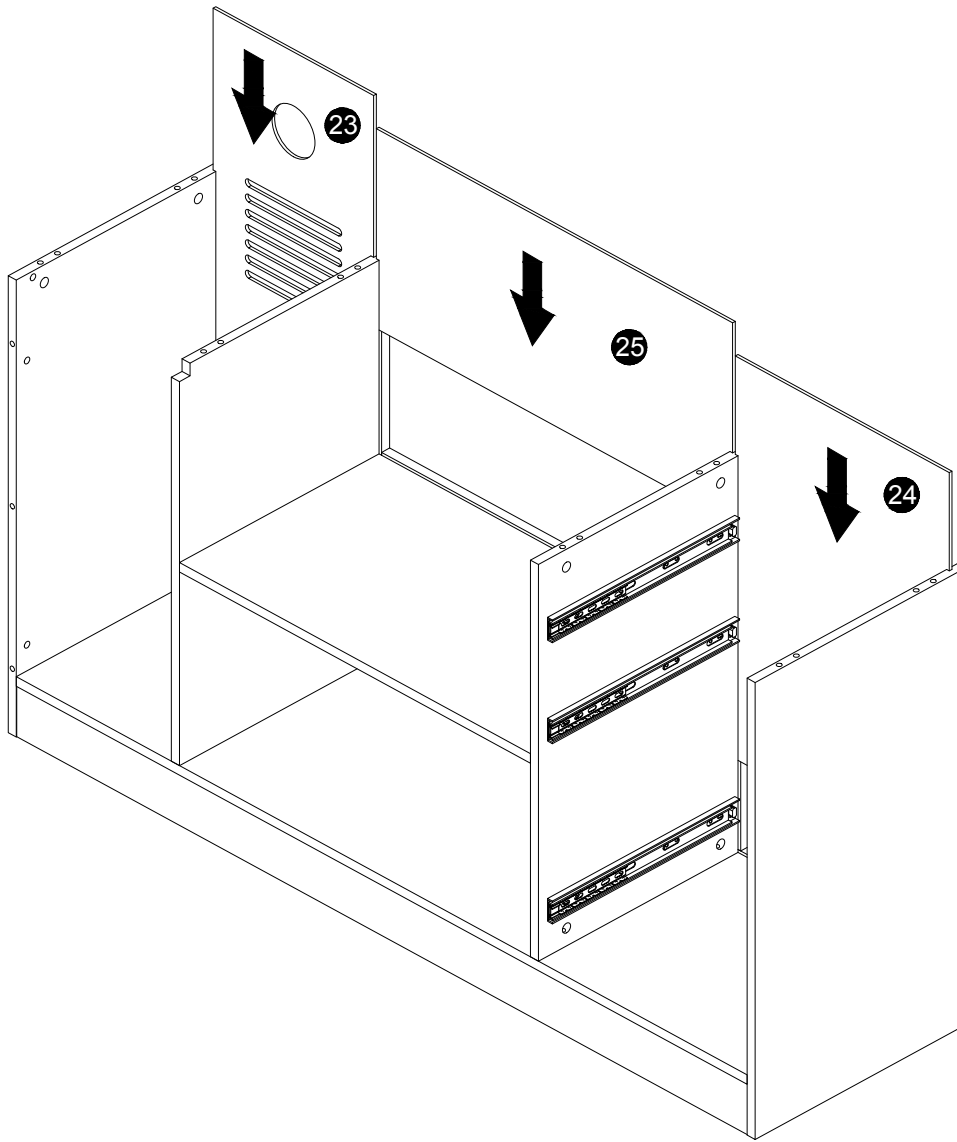

14

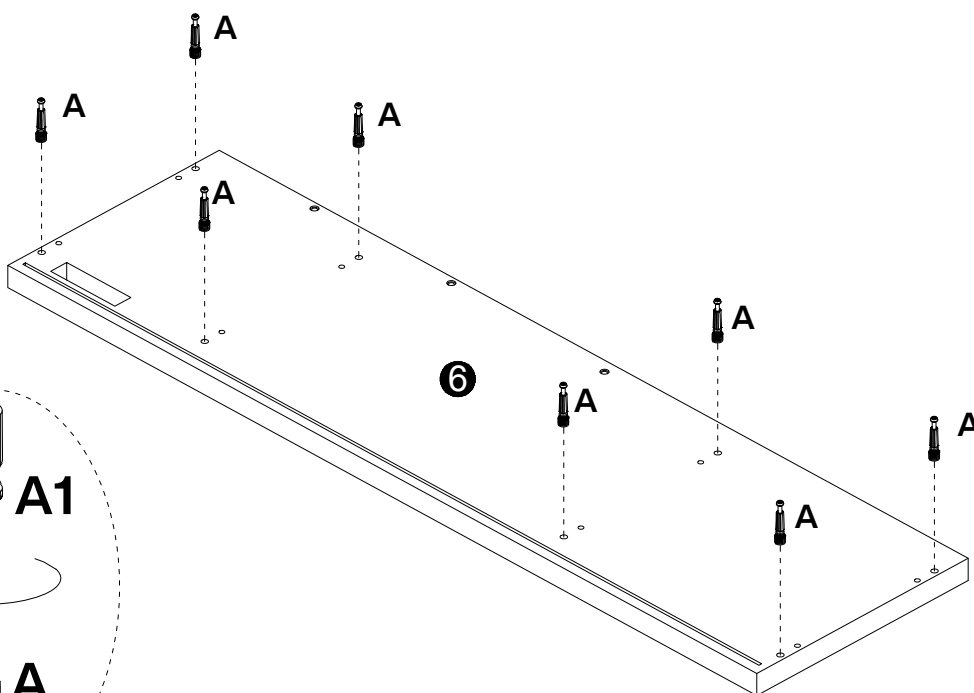

A

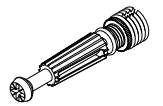

Ø6×40mm

8 pcs

15

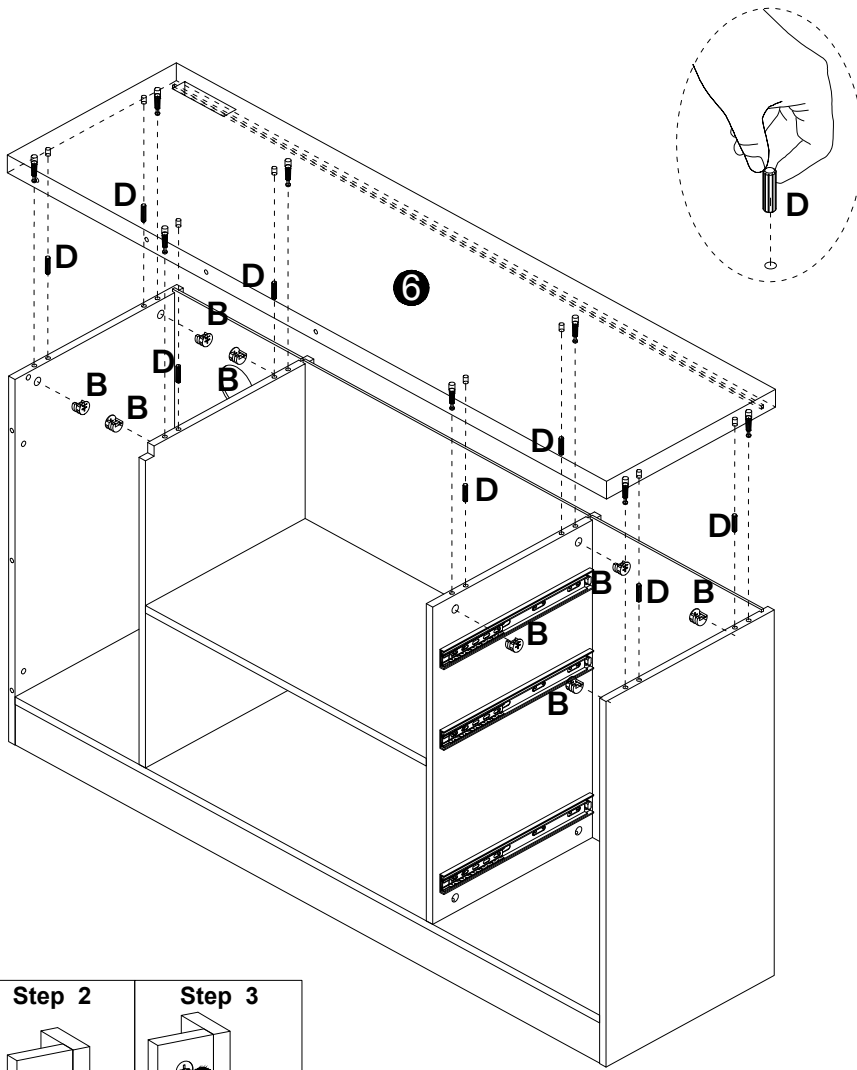

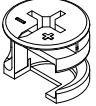
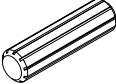
<b>B</b>

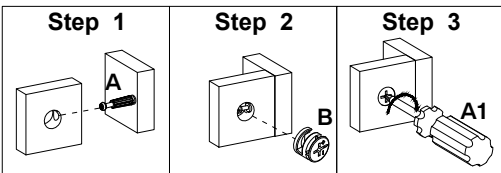
Ø15×12mm
8 pcs
<b>D</b>

Ø8×30mm
8 pcs

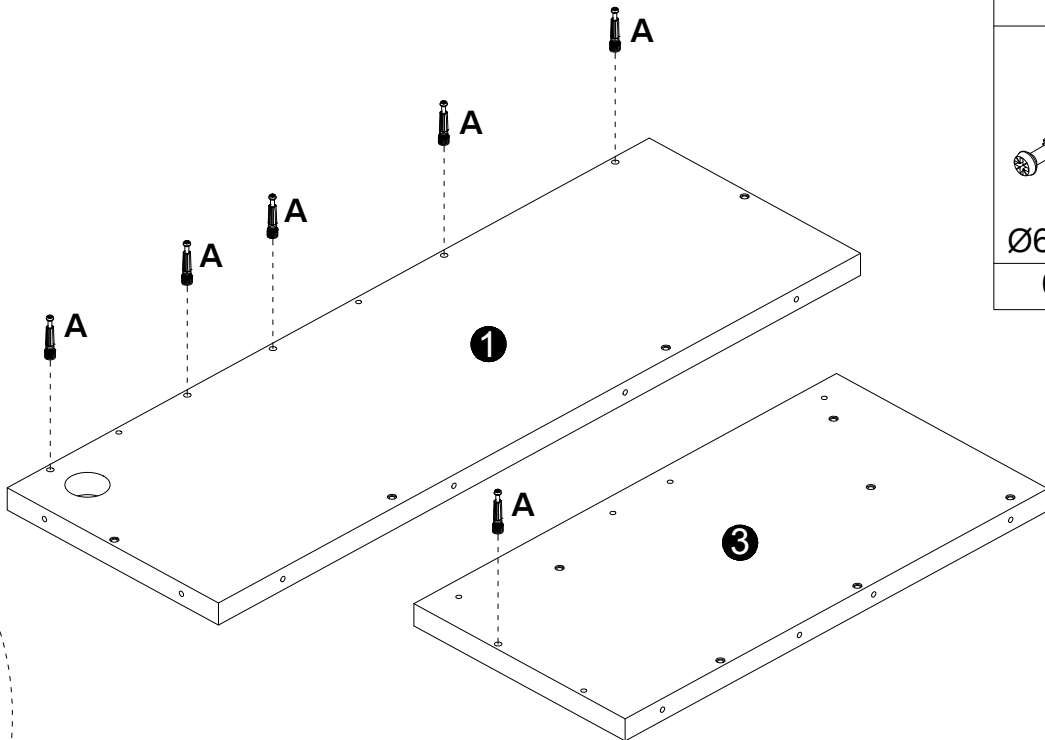

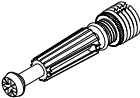
16

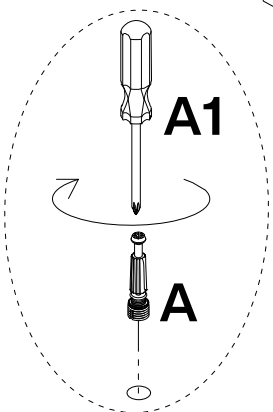

<b>A</b>

Ø6×40mm
6 pcs

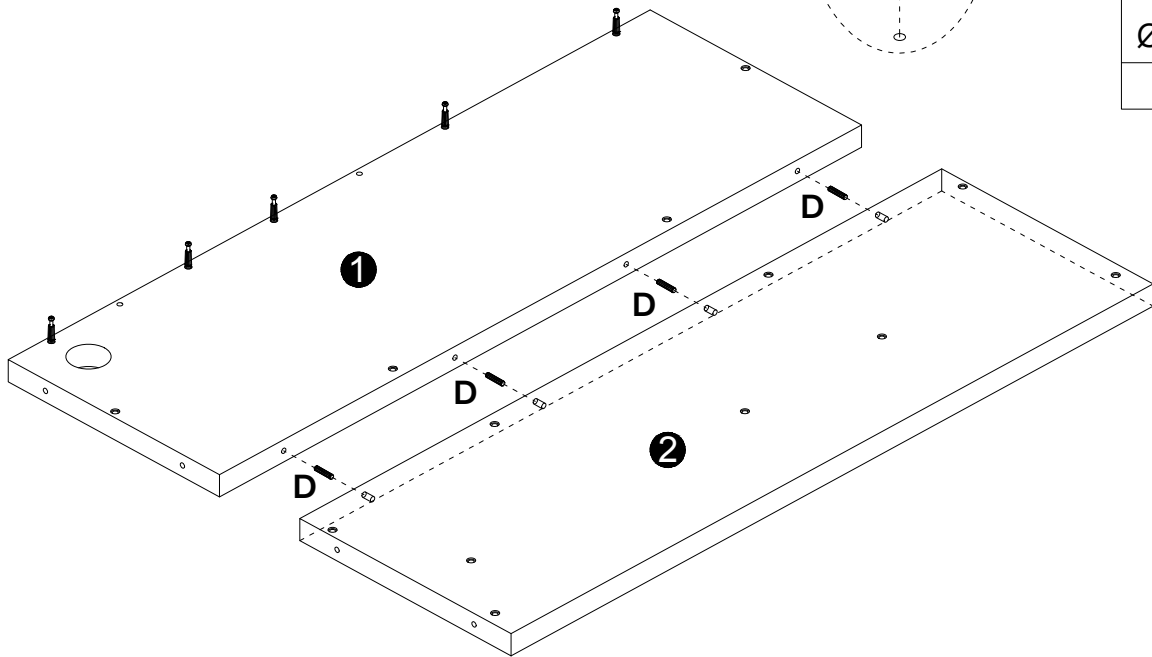

17

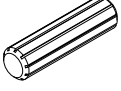

D

Ø8×30mm
4 pcs

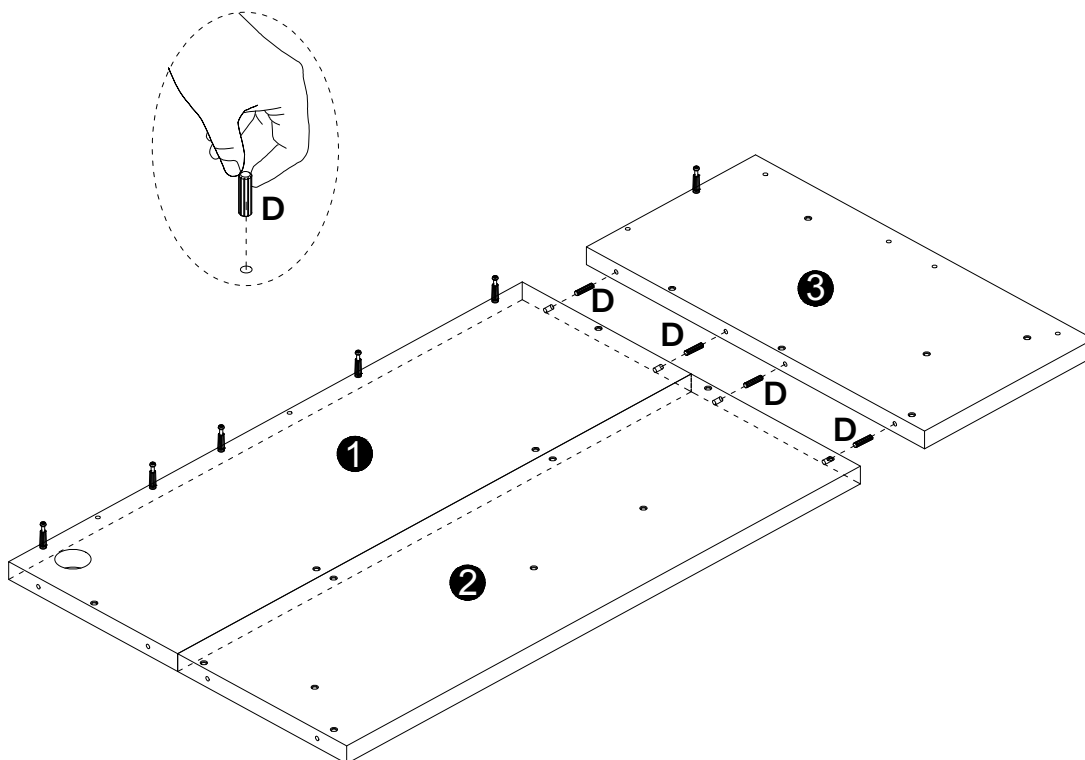
18

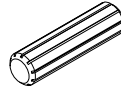

D

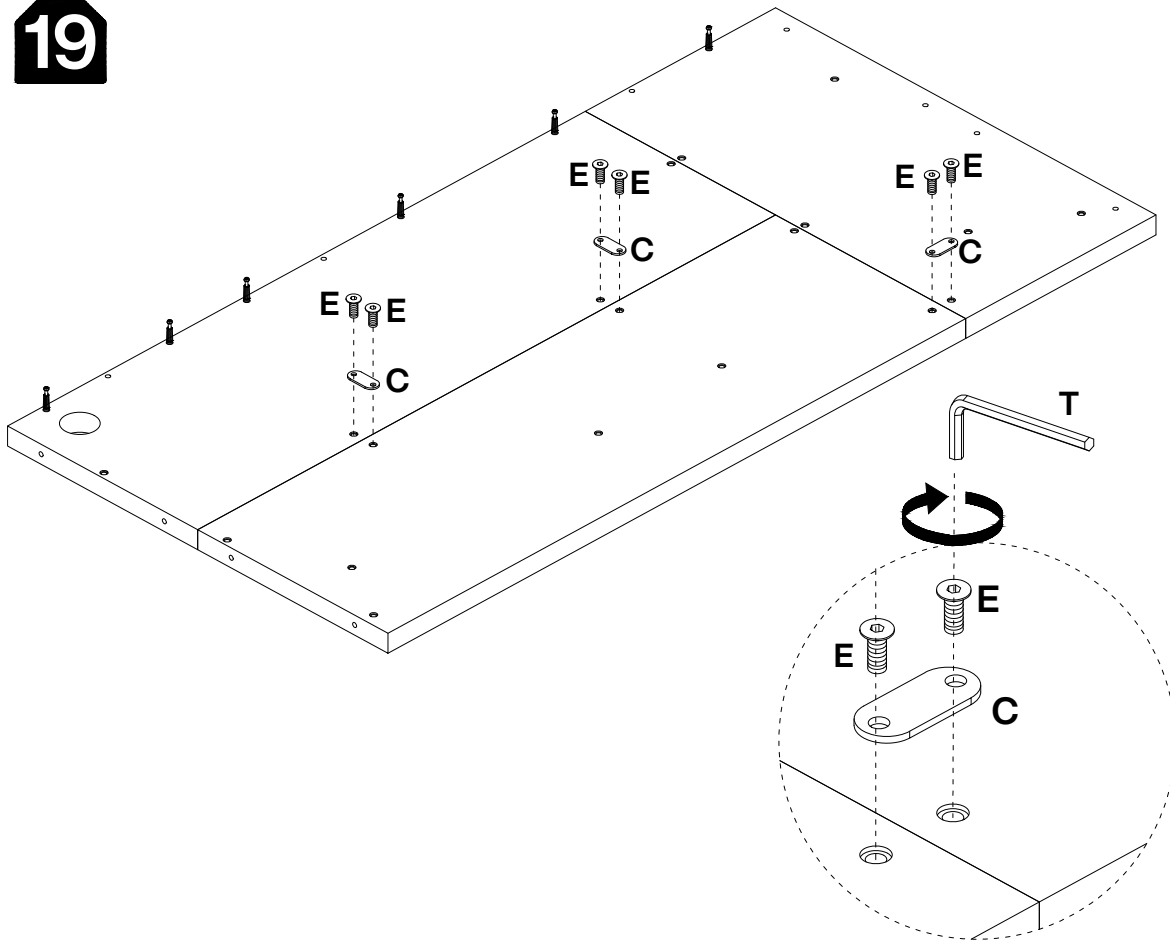
Ø8×30mm
4 pcs

19

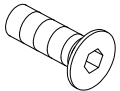
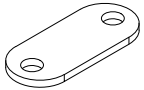

<b>E</b>

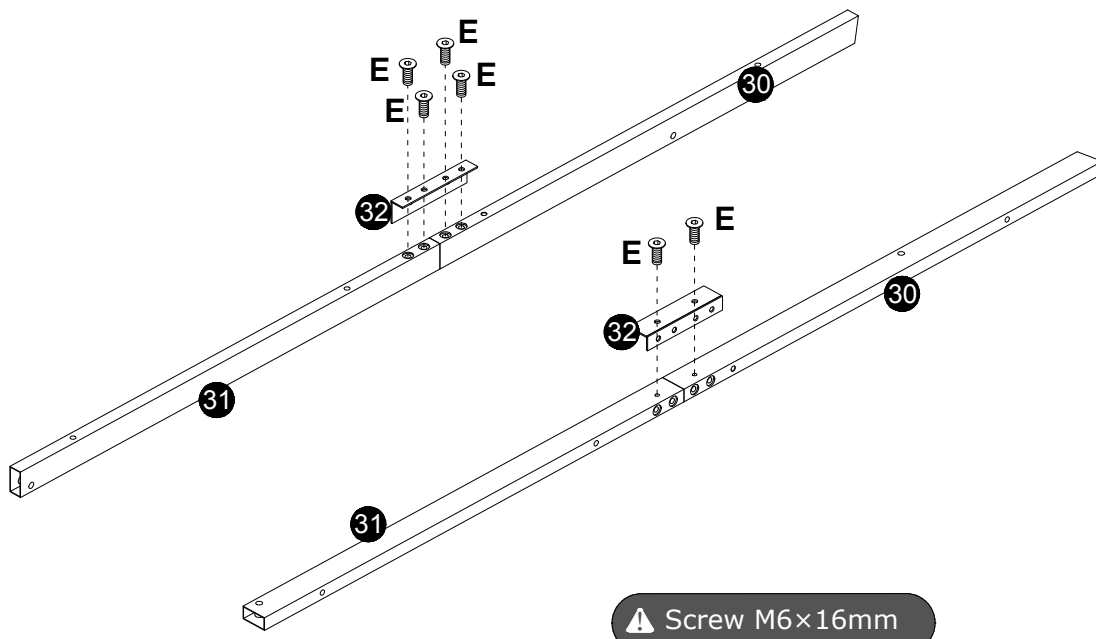
Ø6×16mm
6pcs
<b>C</b>

3pcs

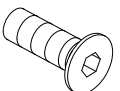
20

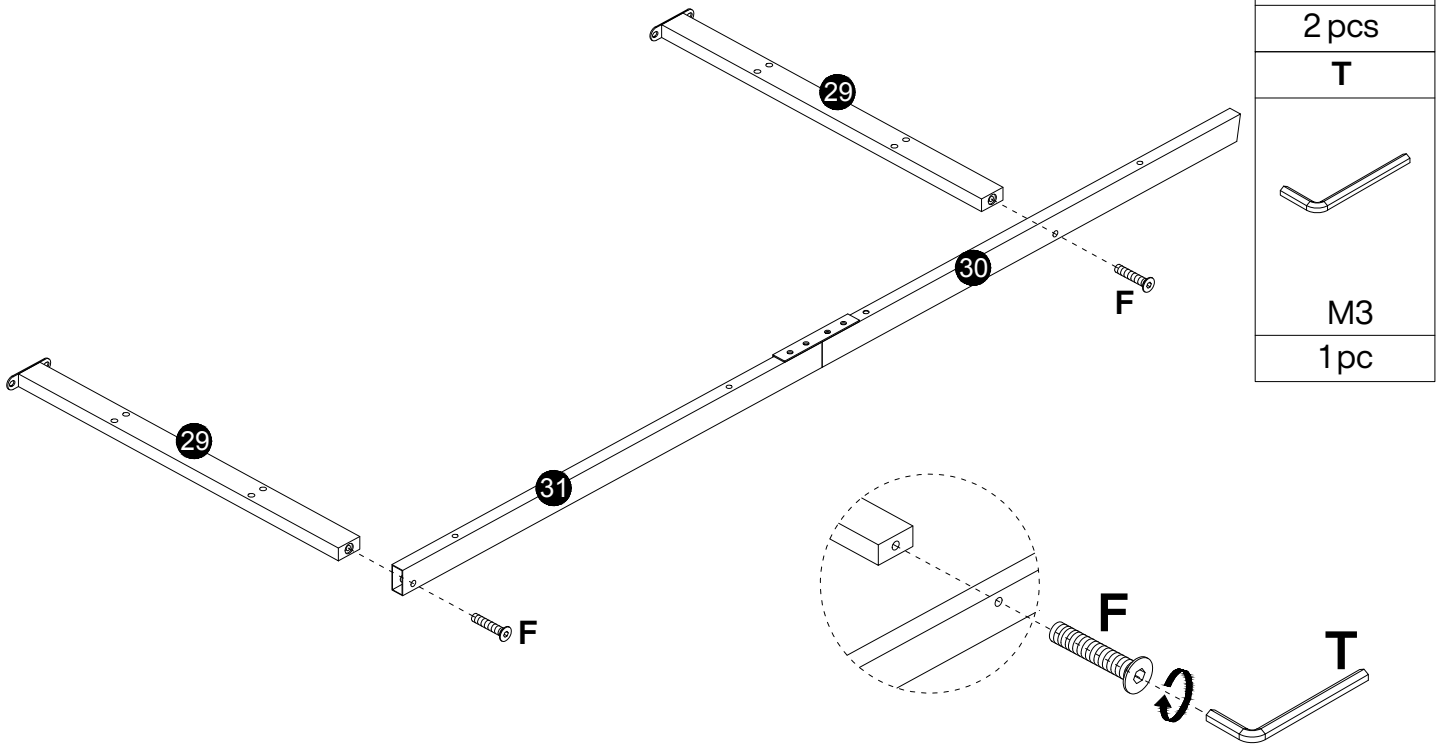

<b>E</b>

Ø6×16mm
6pcs

21

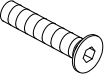
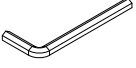

<b>F</b>

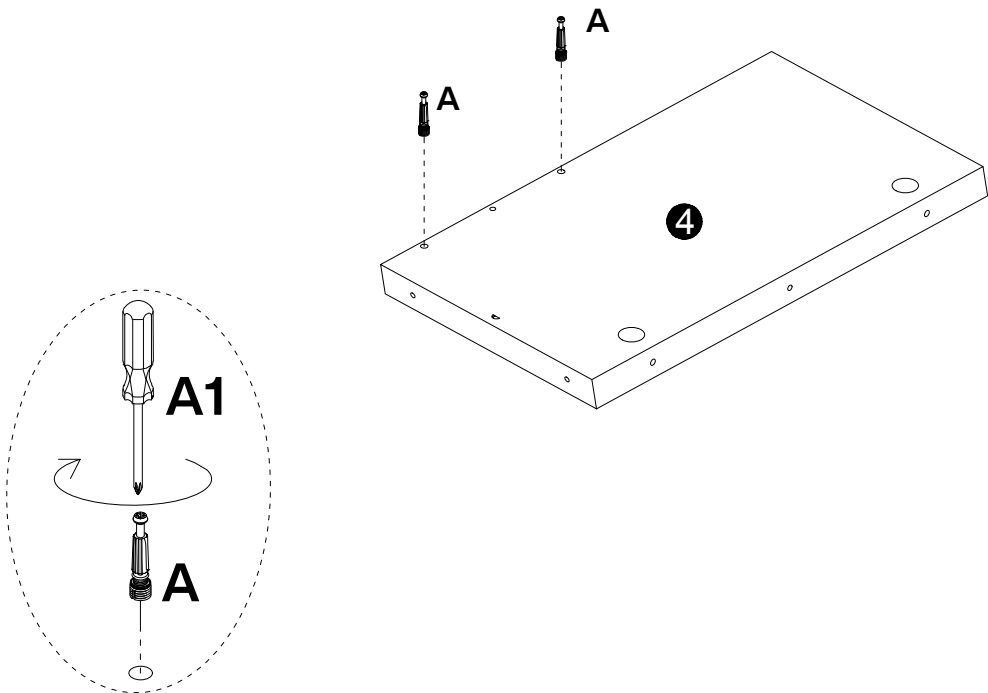
Ø6×35mm
2 pcs
<b>T</b>

M3
1 pc

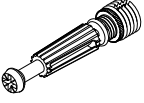

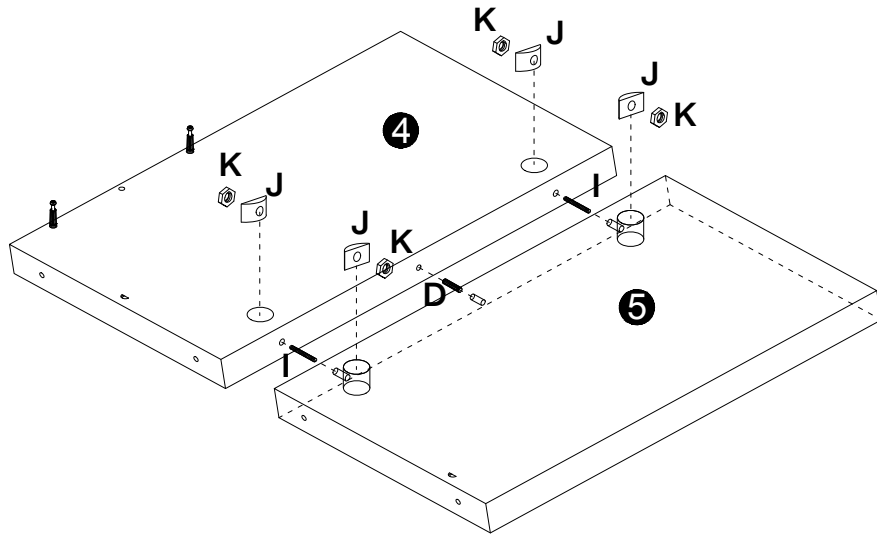
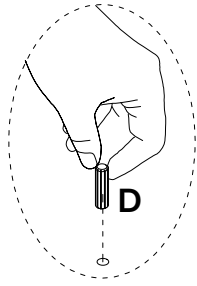

22



<b>A</b>

Ø6×40mm
2 pcs

23

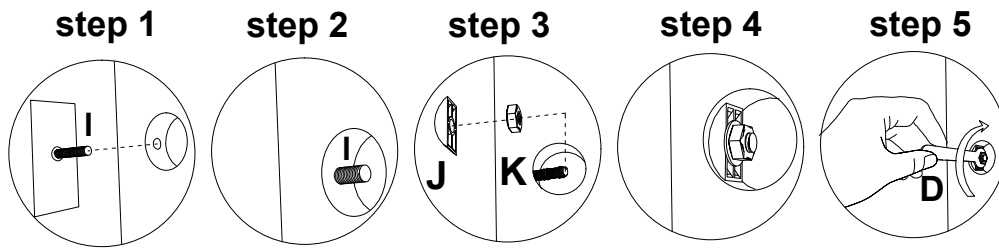

<b>D</b>	<b>I</b>
 Ø8×30mm 1 pcs	 Ø8×90mm 2 pcs
<b>J</b>	
 M8 4 pcs	
<b>K</b>	
 M8 4 pcs	
<b>L</b>	
 M14 1 pc	



24

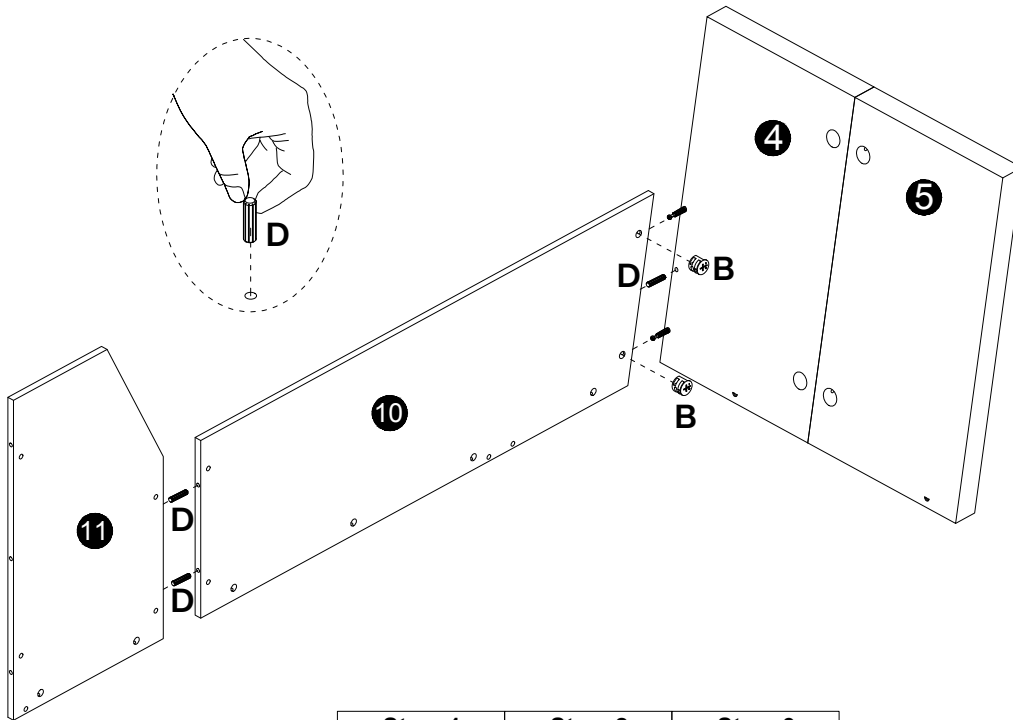
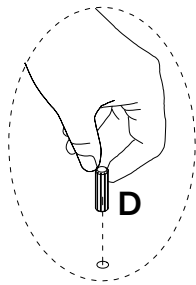

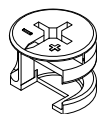
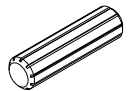
<b>B</b>
 Ø15×12mm 2 pcs
<b>D</b>
 Ø8×30mm 3 pcs

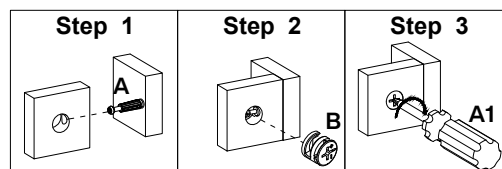

25

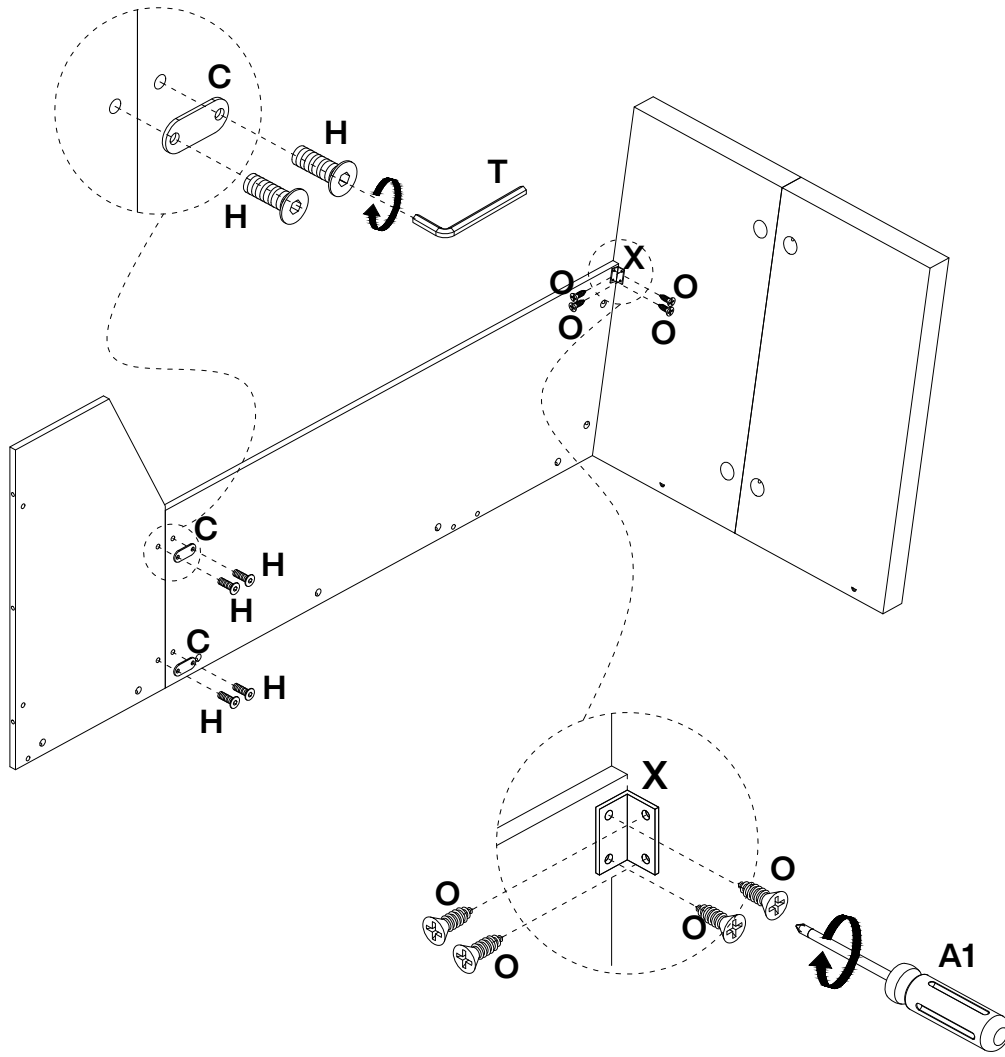

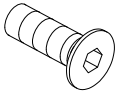
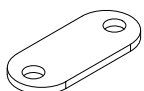
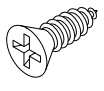
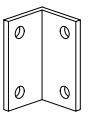
<b>H</b>

Ø6×10mm
4 pcs
<b>C</b>

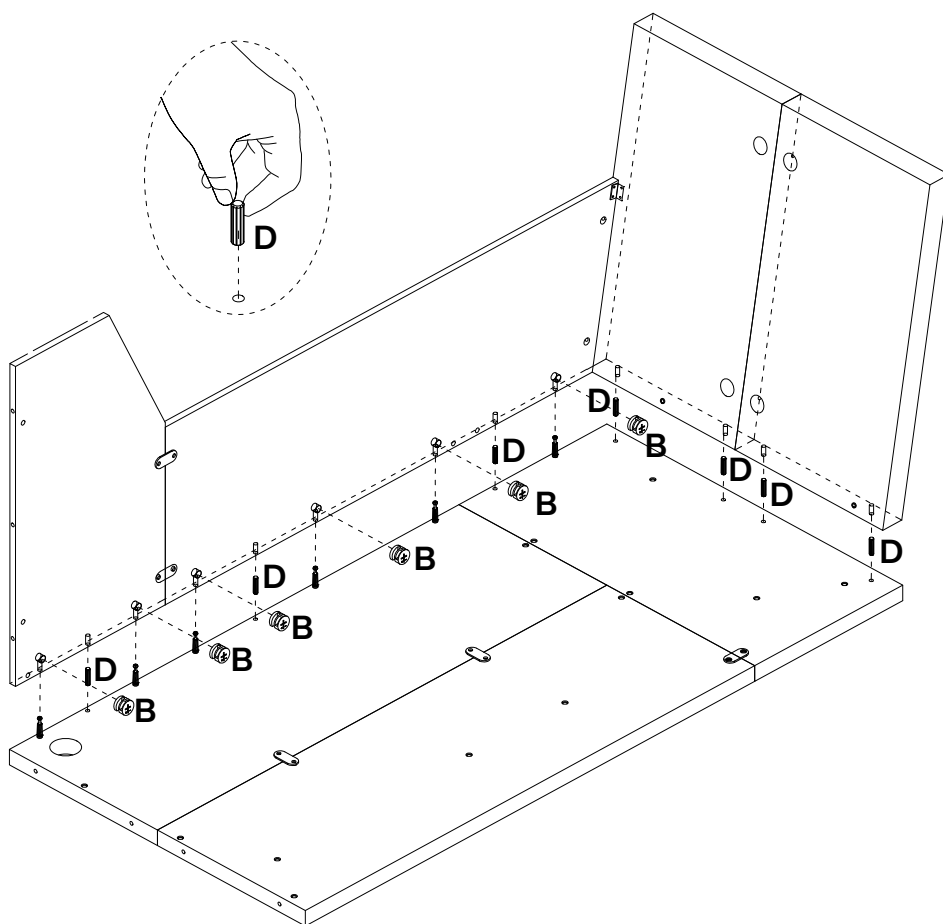
2 pcs
<b>O</b>

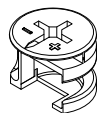
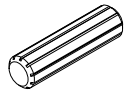
Ø3.5×14mm
4 pcs
<b>X</b>

1 pc

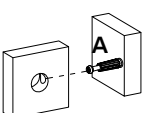
26



<b>B</b>

Ø15×12mm
6 pcs
<b>D</b>

Ø8×30mm
7 pcs

**Step 1**

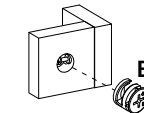

**Step 2**





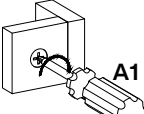

**Step 3**

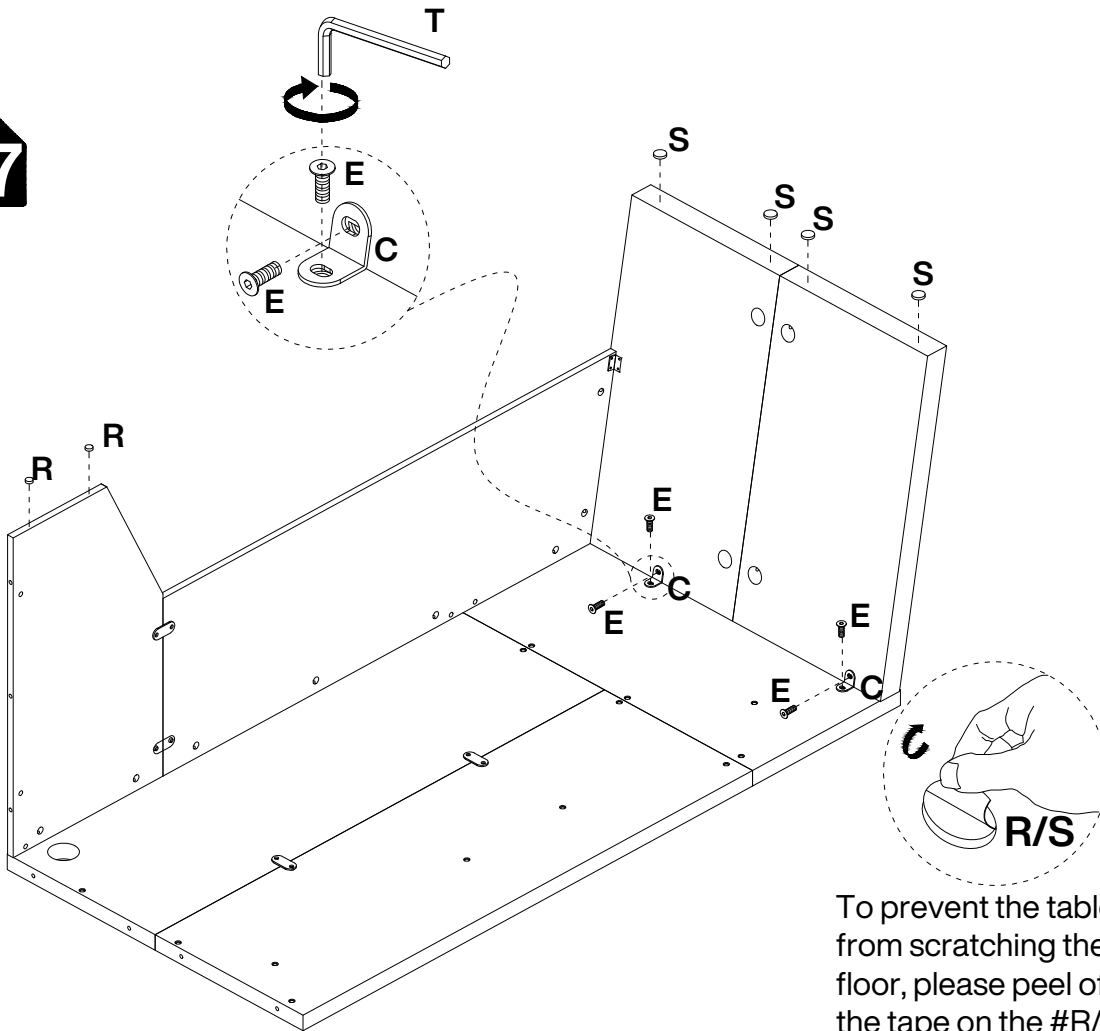

27

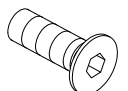

To prevent the table from scratching the floor, please peel off the tape on the #R/S and tape them to the corners of the table before use.

<b>S</b>

Ø25×2mm
4 pcs
<b>C</b>

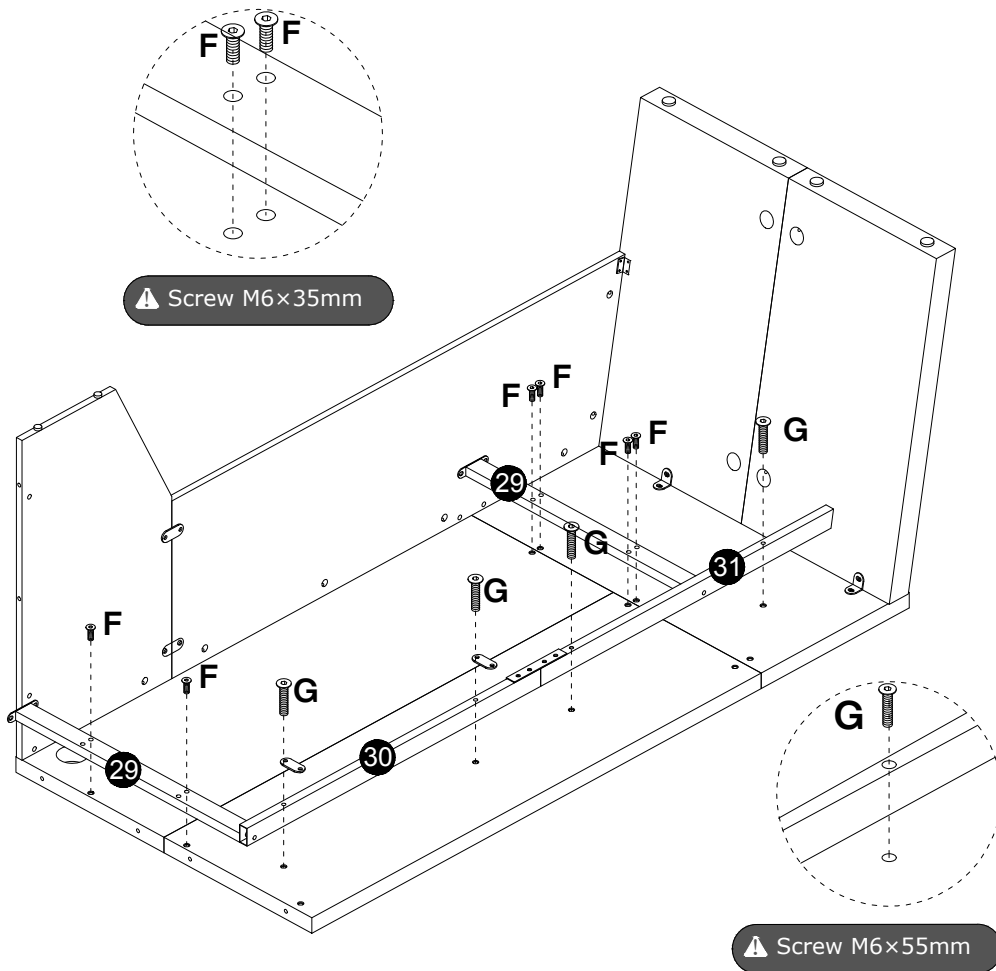
2 pcs
<b>E</b>

Ø6×16mm
4 pcs
<b>R</b>

Ø15×2mm
2 pcs

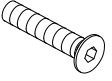
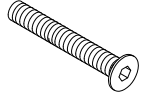
28



⚠ Screw M6×35mm

⚠ Screw M6×55mm

<b>F</b>

Ø6×35mm
6 pcs
<b>G</b>

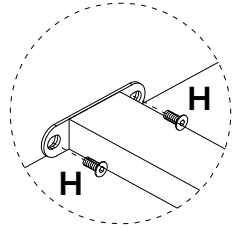
Ø6×55mm
4 pcs

29

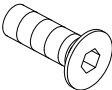

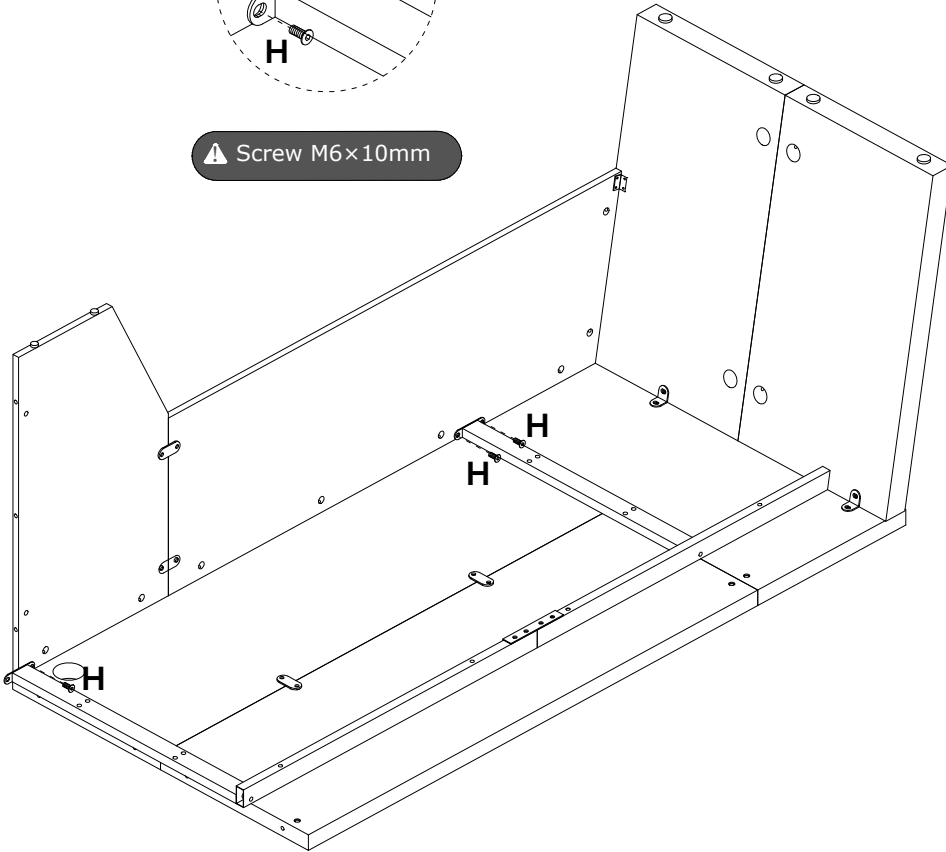
⚠ Screw M6×10mm

H

Ø6×10mm
3 pcs

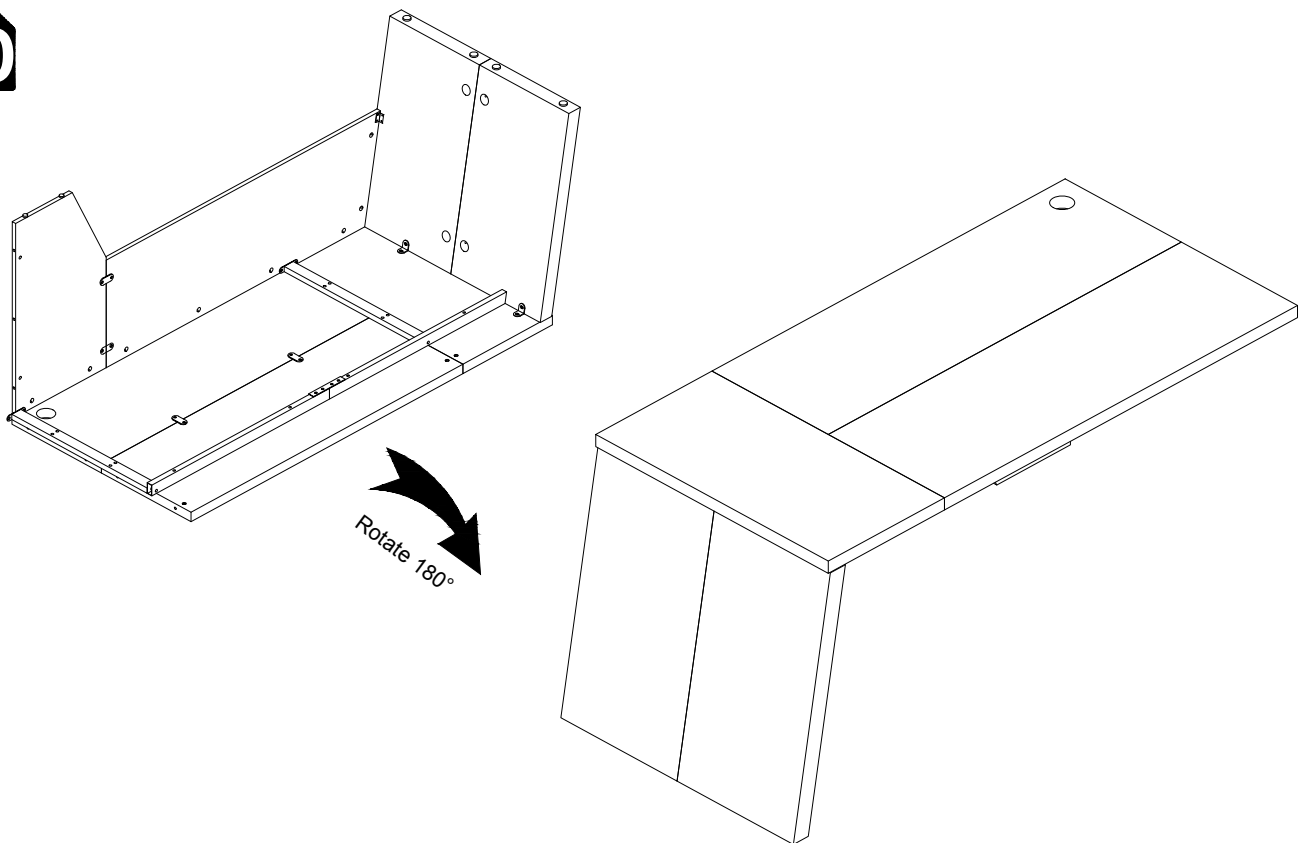

30

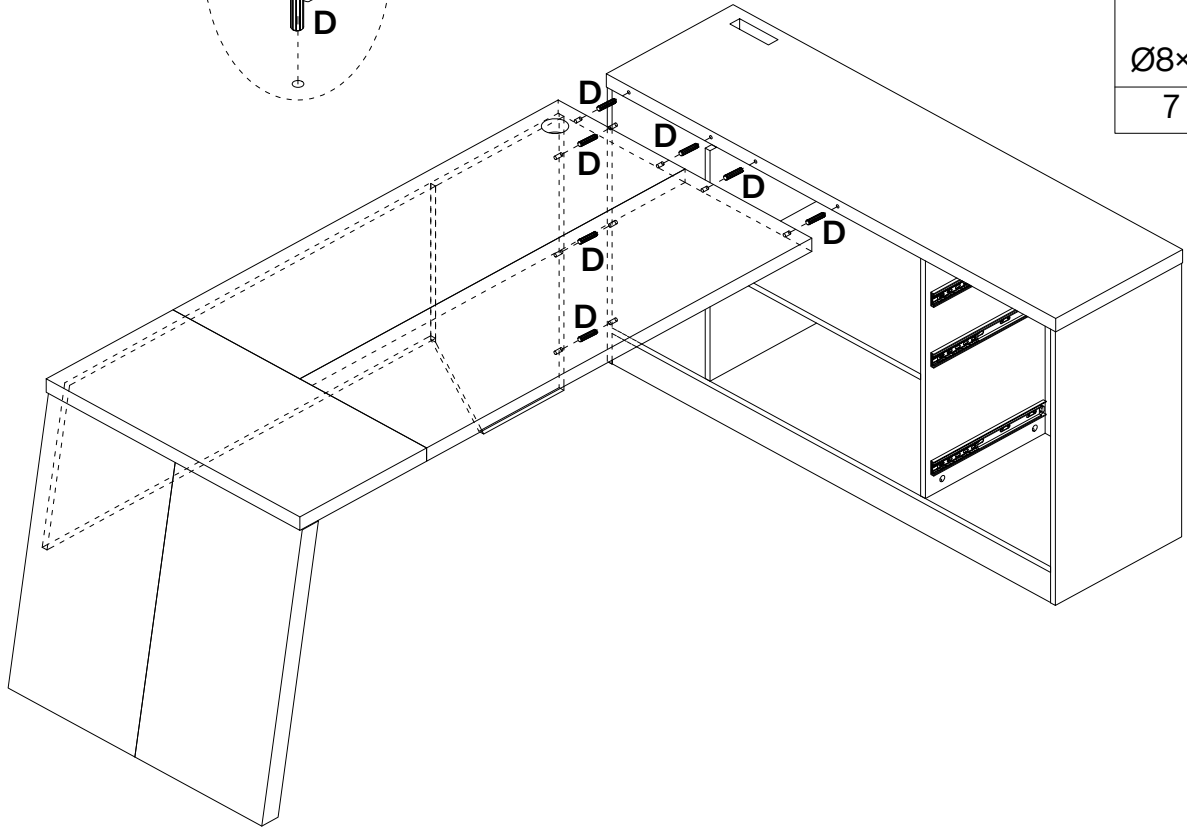
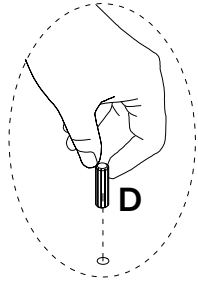

31

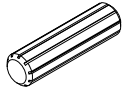

<b>D</b>

Ø8×30mm
7 pcs

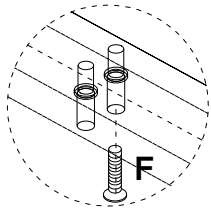
32

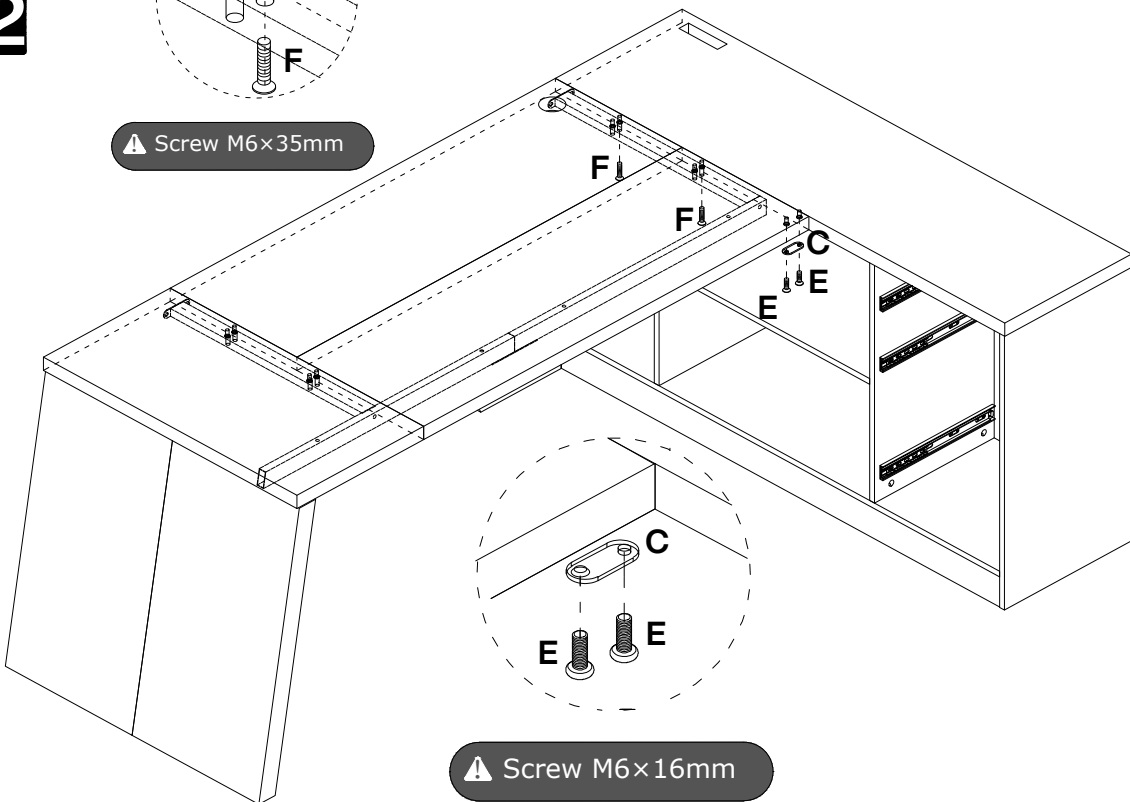

⚠ Screw M6×35mm

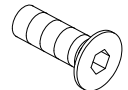
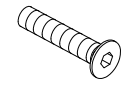
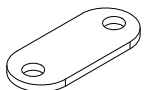

⚠ Screw M6×16mm

<b>E</b>

Ø6×16mm
2 pcs
<b>F</b>

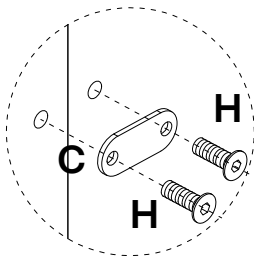
Ø6×35mm
2 pcs
<b>C</b>

1 pc

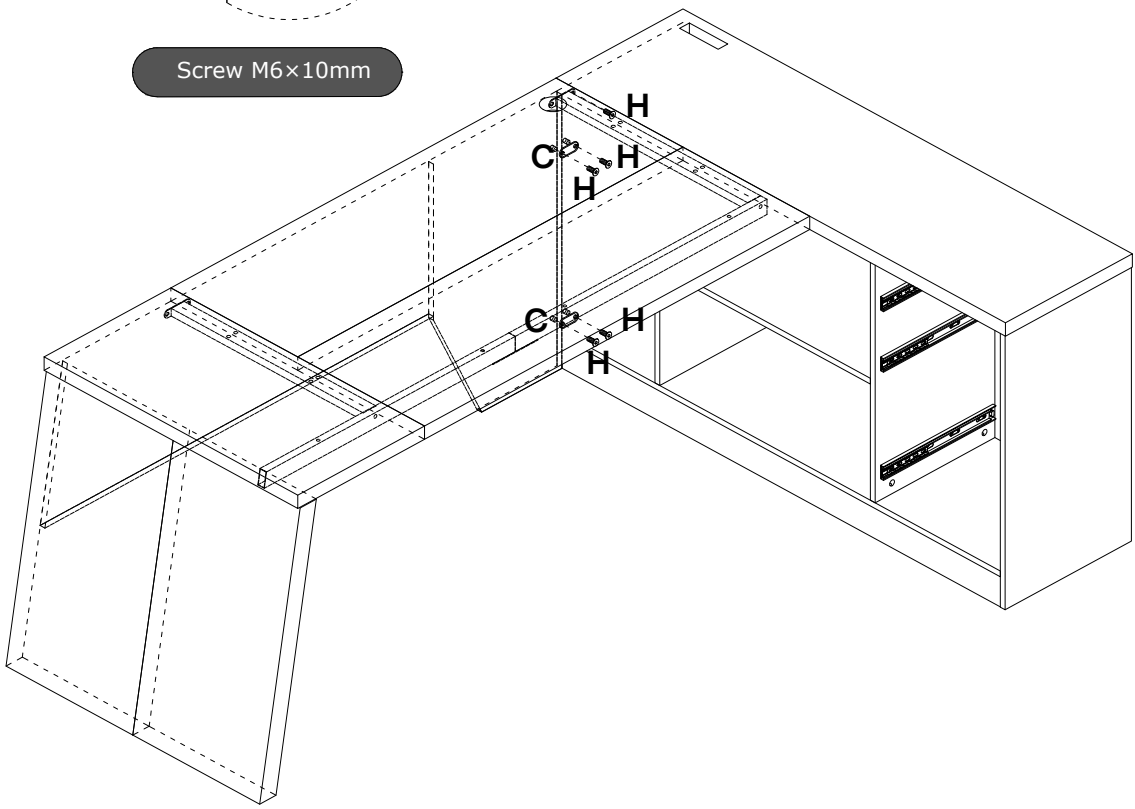
33

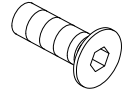
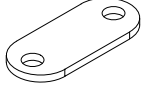

Screw M6×10mm



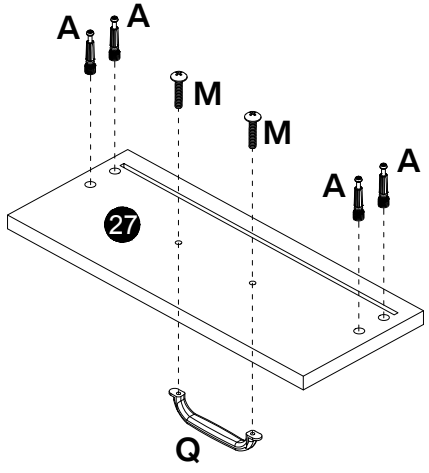
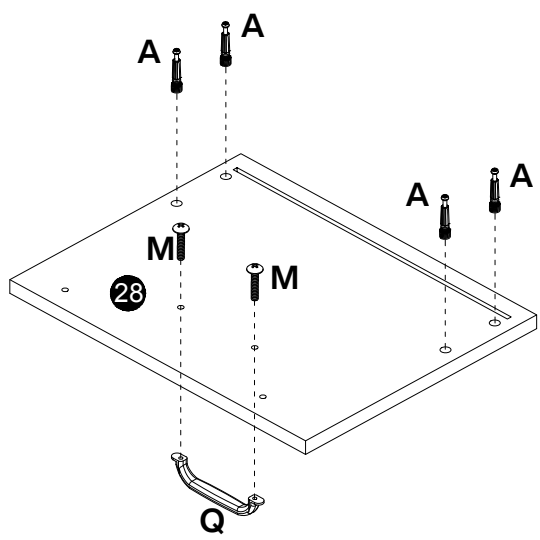
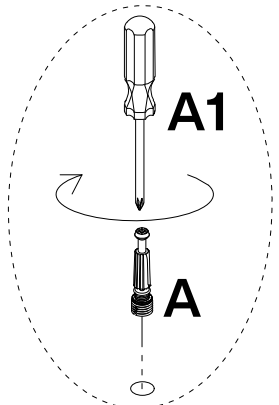

<b>H</b>
 Ø6×10mm
5 pcs
<b>C</b>

2 pcs

34

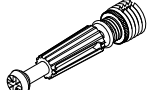

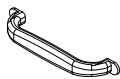
**x 2**

<b>A</b>
 Ø6×40mm
12 pcs
<b>M</b>
 Ø4×20mm
6 pcs
<b>Q</b>

3 pcs

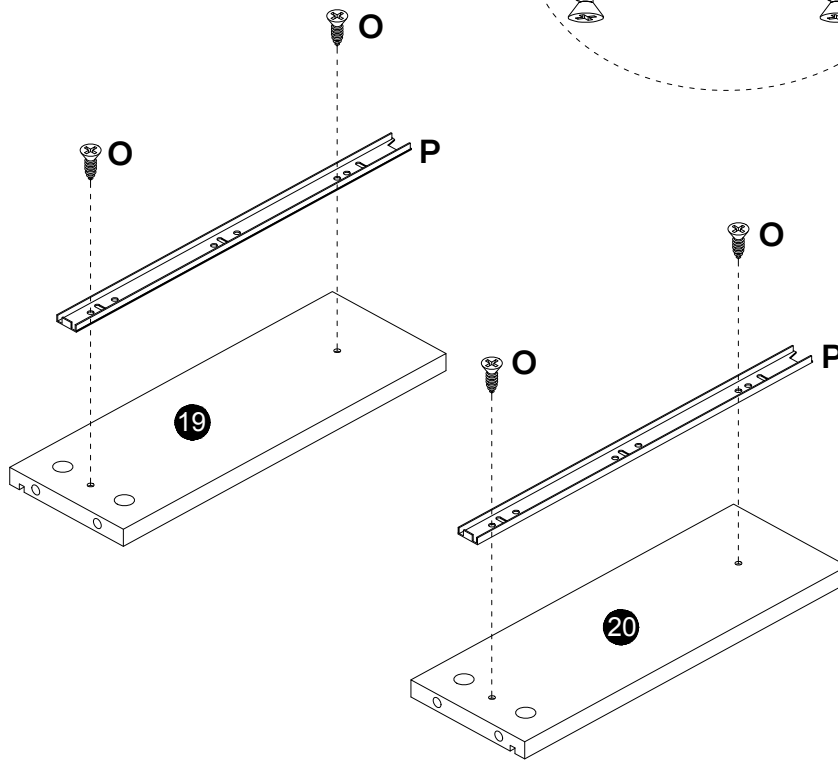
35



<b>P</b>

L350mm
1sets
<b>O</b>

Ø3.5×14mm
4 pcs

36

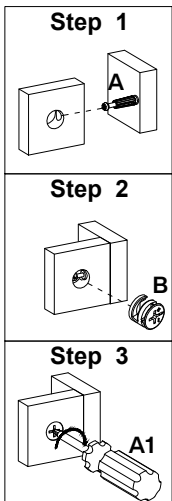
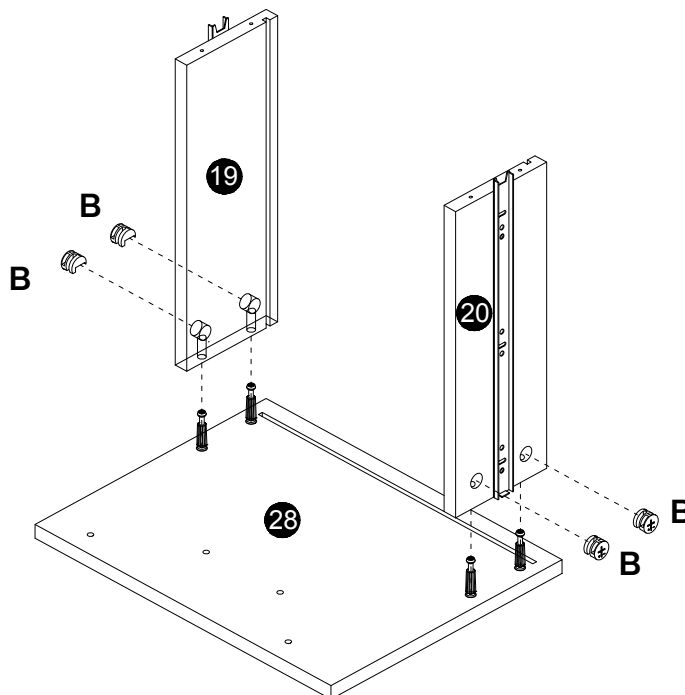

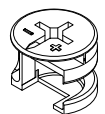
<b>B</b>

Ø15×12mm
4 pcs

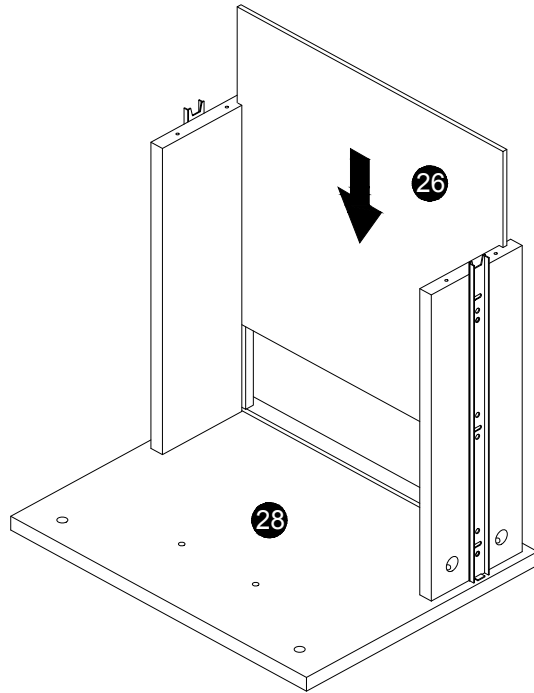
37

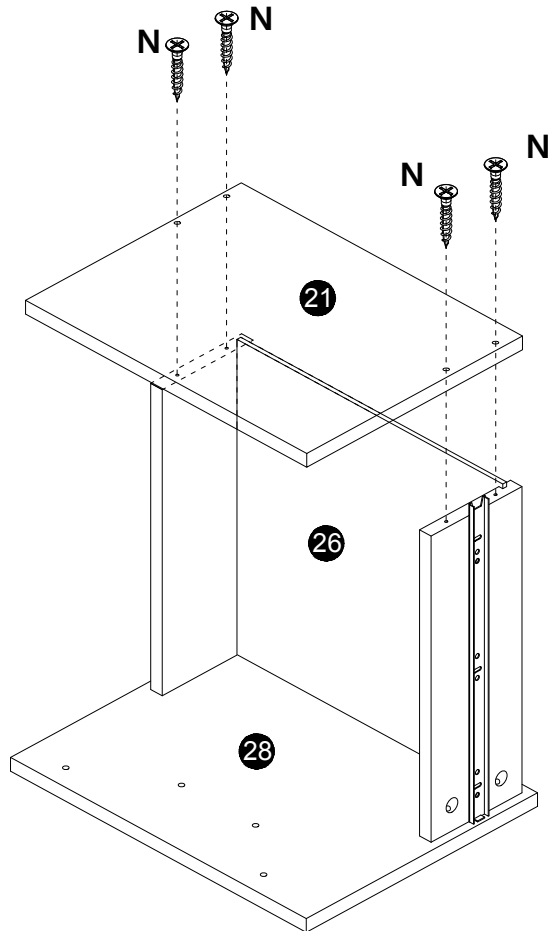

38

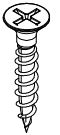

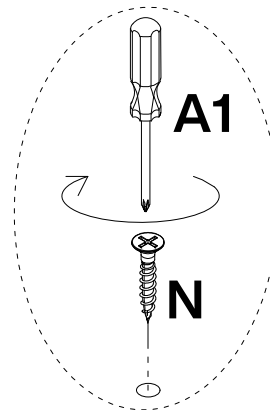

N

Ø3.5×35mm
4 pcs

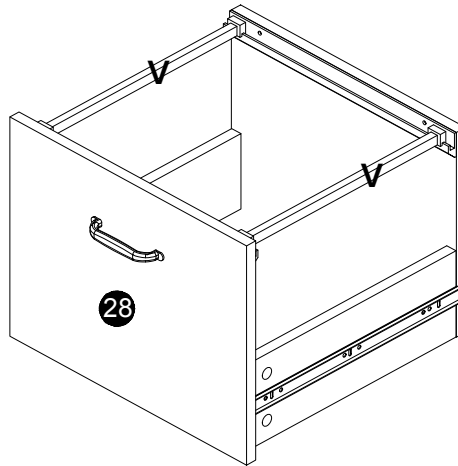
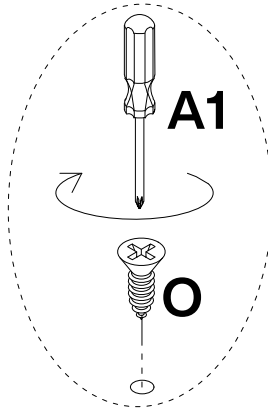
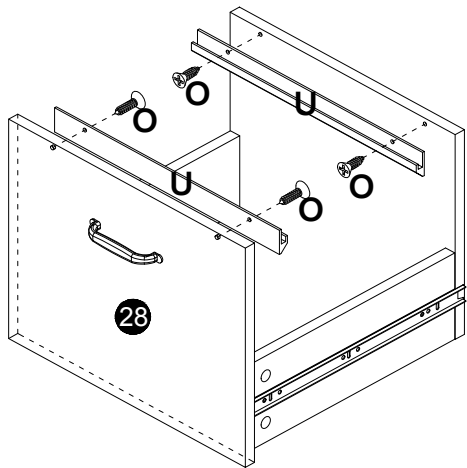

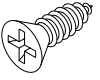
39



O

Ø3.5×14mm
4 pcs
U

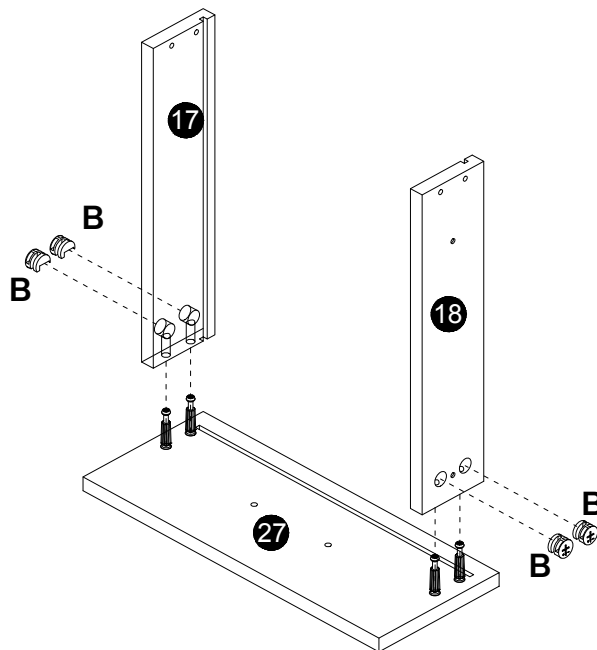
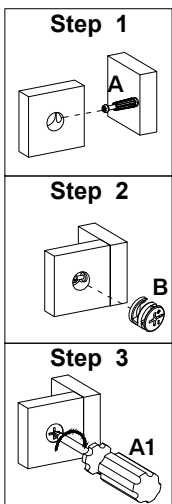
365×35×16mm
2 pcs
V

318×25×22mm
2 pcs

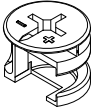
40



**X 2**

B

Ø15×12mm
8 pcs

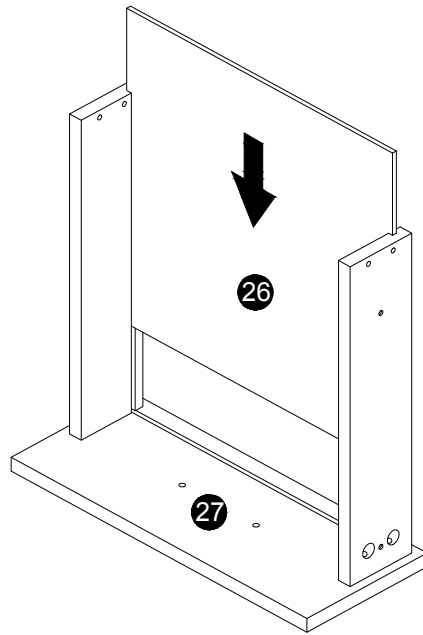
41

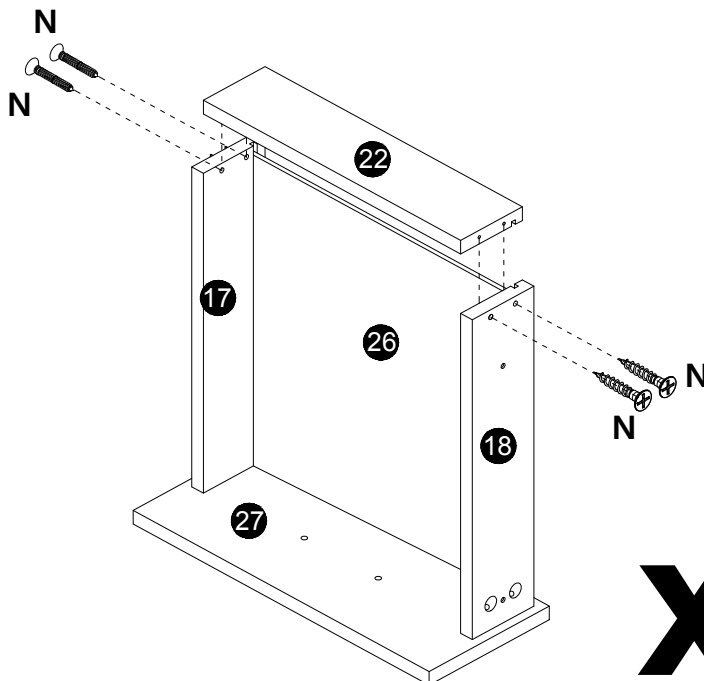

x 2

42



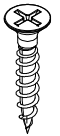

N

Ø3.5×35mm
8 pcs

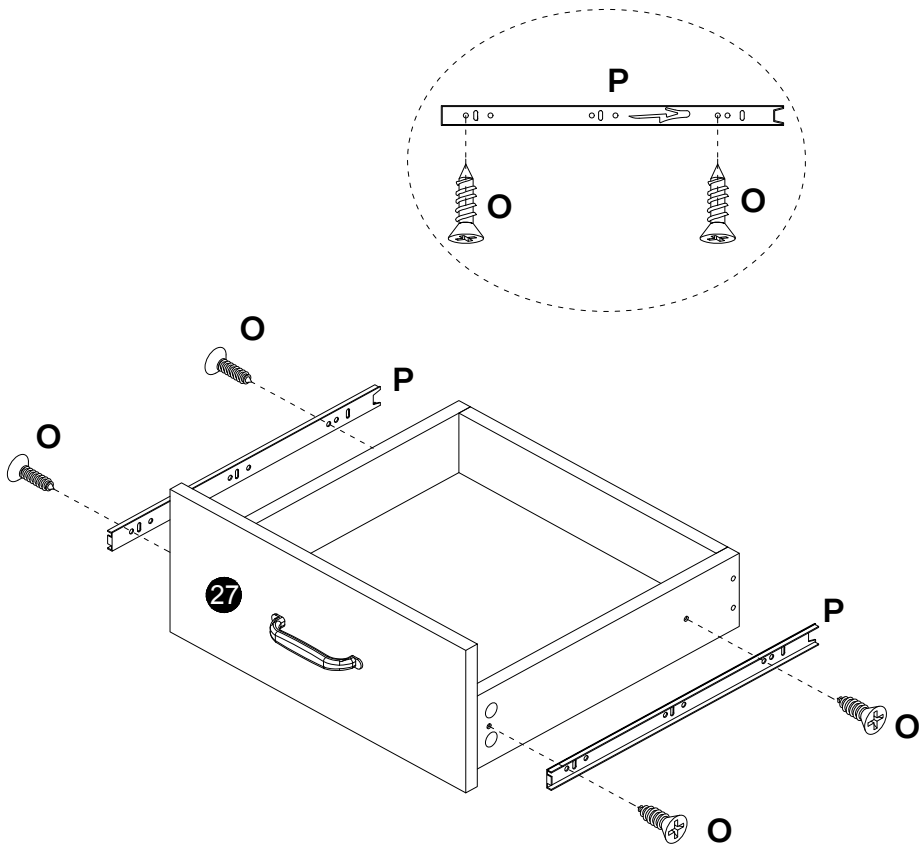
x 2

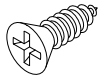
43



O

Ø3.5×14mm
8 pcs
P

L350mm
2sets

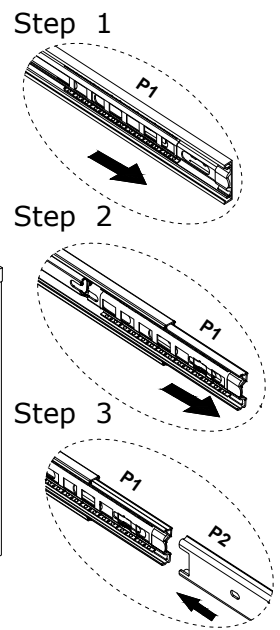
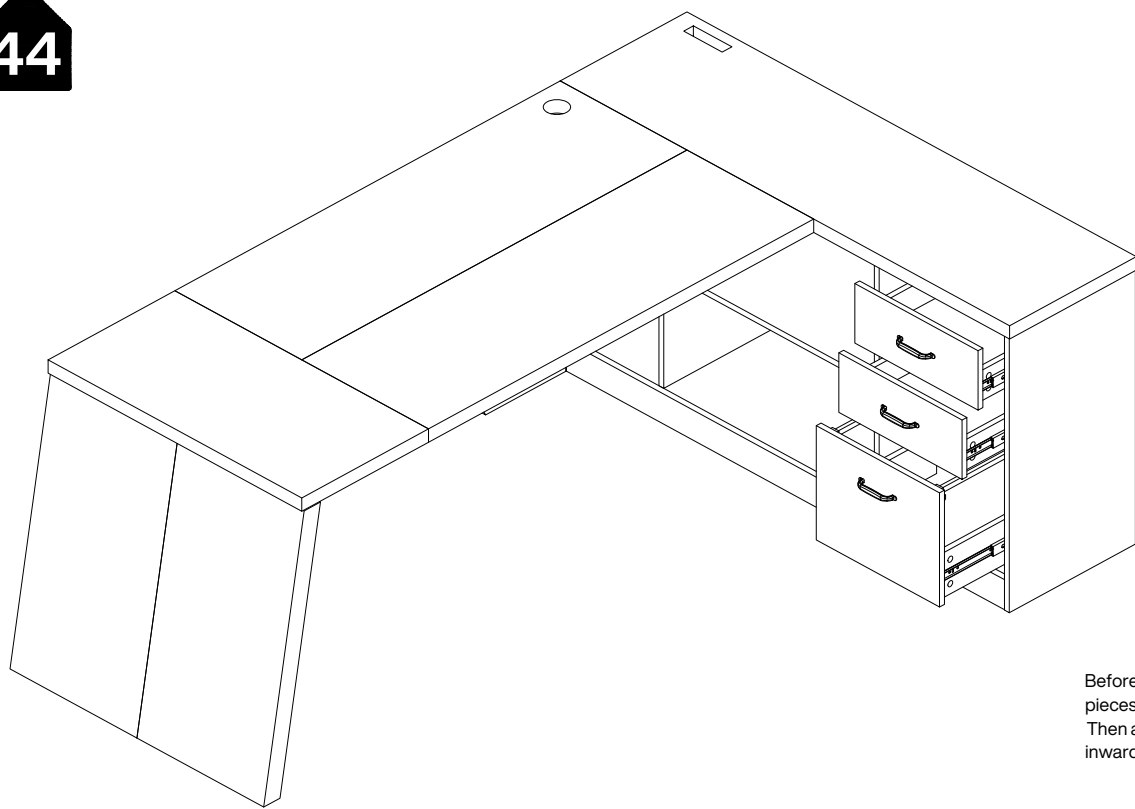
x 2



44

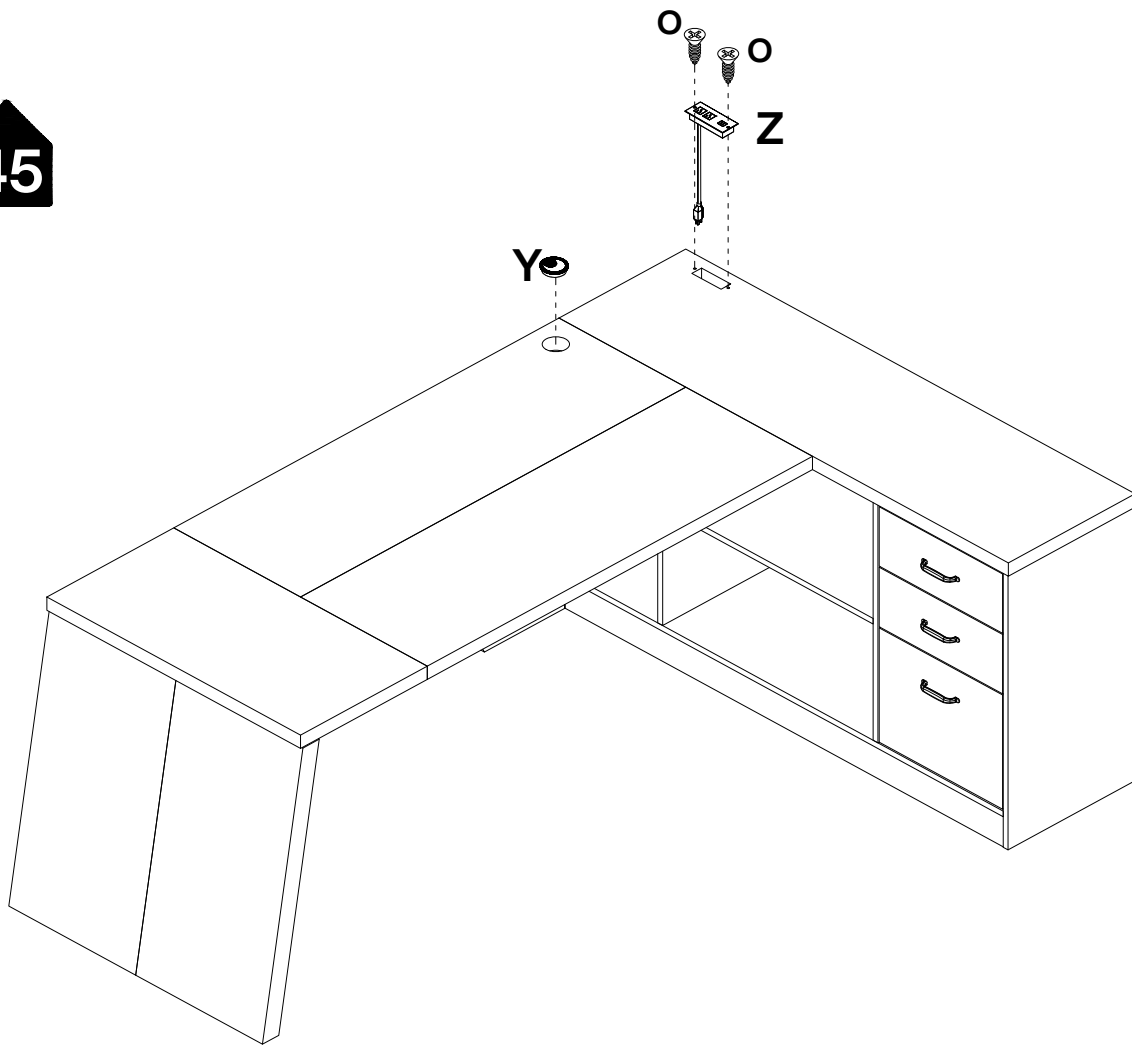

Before installation, slide the inner iron pieces of #P1 to the outermost side. Then align it with #P2 and gently push it inward to complete the slide installation.

45

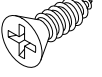

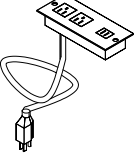
O

Ø3.5×14mm
2 pcs
Y

1pc
Z

1pc

46

