

Thank you for choosing Our Decor. We stand behind our brand and the quality of the items we sell. Replacement parts or products will be sent at our discretion within the 1-year warranty period. Proof of purchase, with the date of purchase as well as photos of the merchandise defect, must be provided. Photos are used to determine the cause of defects and for future quality control.

# CASCADING TOWER OUTDOOR METAL WATER FOUNTAIN WITH LED LIGHTS

Read all assembly and care instructions carefully before using this product. Save this manual for future reference.  
 Assemble components on a soft, clean surface to avoid damaging the finish.  
 Select a smooth, level surface to place the fountain.

 Ensure all parts are accounted for before disposing of packaging.

PARTS	QTY.
Fountain Body	1
Basin	1
Electric Submersible Pump	1
AC Adapter	1



**NOTE:** The water tubing is built into the fountain. Take care when handling the water tube; detaching the water tube from the fountain will damage the fountain and void the product warranty.

 Cascading water sound

Over time, the finish may gradually mellow in color; this is part of the natural aging process.

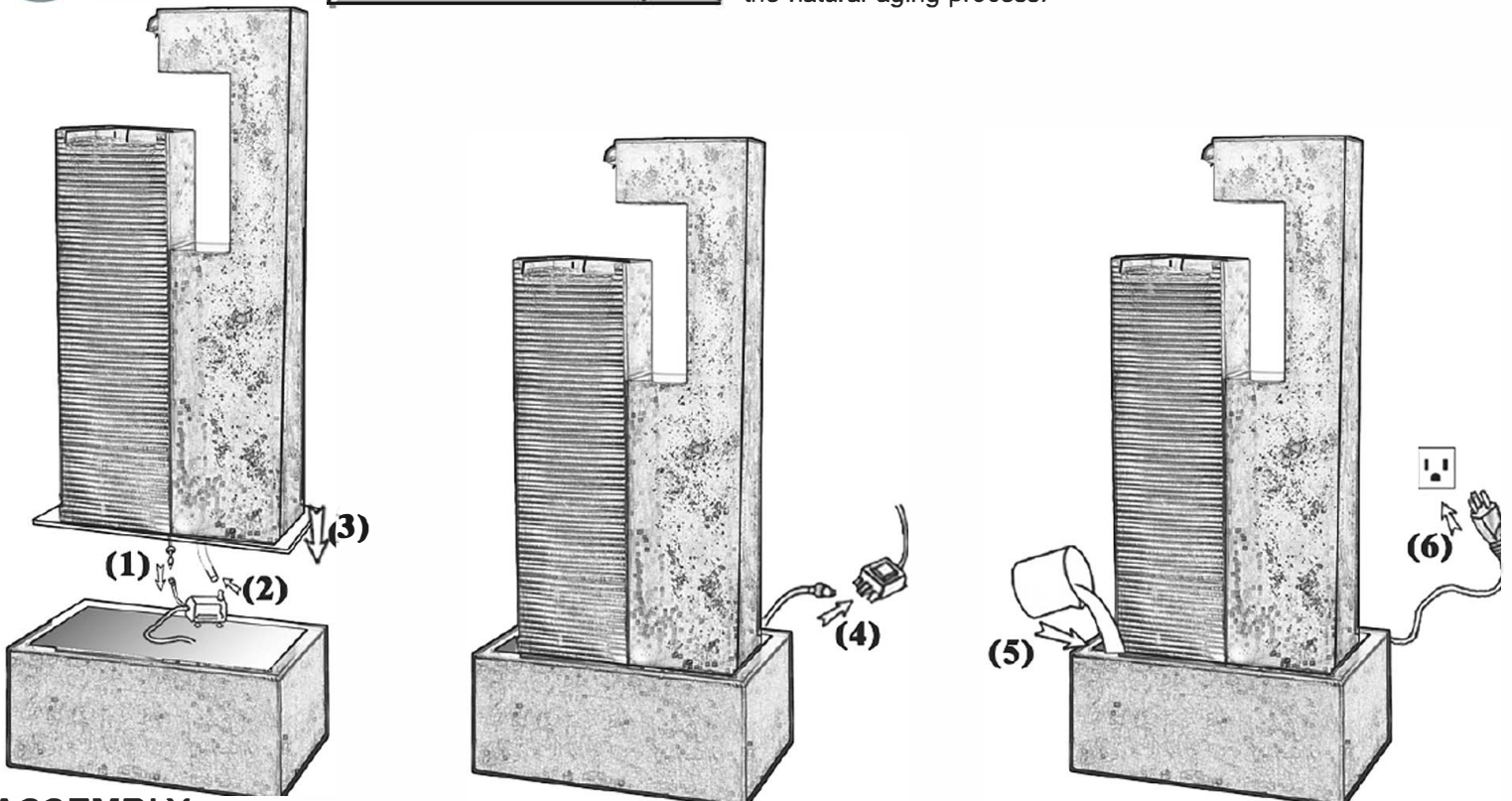

## ASSEMBLY

1. Locate the light cable in the fountain body and connect it to the shorter cable on the pump.
2. Connect the pump to the water tube that is built into the fountain body.
3. Gently place the fountain body into the basin, ensuring the long pump cable runs out the groove in the back of the fountain body.
4. Firmly connect the pump power cable to the AC adapter.
5. Fill the basin with enough water to keep the pump fully submerged during operation, approximately 2.5 gallons.
6. Plug the power cord into a properly grounded GFCI outlet.

**NOTE:** When first used, there may be air in the pump. It may take several minutes for trapped air to escape, allowing water to flow. Refer to page 2 for more troubleshooting tips.

# Care & Maintenance

- For outdoor use only. Some splashing is normal; adjust the flow rate on the pump if the water rate is too high.
- Check the water level frequently to ensure the pump remains fully submerged; never allow the pump to run dry as it will burn out the motor.
- Some climates and weather conditions increase water evaporation, requiring water to be refilled more frequently. Check water levels often during times of high temperatures, wind, and long-term exposure to direct sunlight to ensure the pump does not run dry.
- Only use water in this fountain. Distilled water will help prevent mineral buildup but is not required. Tap water is okay to use; avoid heavily chlorinated water as it may damage the fountain or pump.
- Periodically change the water to keep the water, fountain, and pump clean. Remove scale and buildup regularly.
  - DO NOT use harmful additives such as bleach, chlorine, etc.
  - DO NOT use anything abrasive to scrub the fountain.
  - DO NOT use a pressure washer.
- Always unplug the power supply before cleaning and maintaining the fountain and the recirculating pump.
- Take care when handling the pump; only pick it up by the body of the pump, never the power cord.
- During freezing weather, drain the fountain, disconnect the pump and store indoors; allowing ice to form may damage the fountain in such ways as, but not limited to, the fountain cracking, permanent pump damage, and/or lighting malfunctions.

## Troubleshooting

- If water is not flowing within several moments of the fountain being plugged in, the pump may have air bubbles in the filter, which can prevent water from circulating properly and can also cause excess pump noise.
- Ensure that the pump is fully submerged underwater; add water to the reservoir as necessary.
- Check the flow control on the body of the pump, as it may need to be adjusted to achieve the desired water flow rate.
- Inspect the pump and tubing for obstructions.
- Pump noise can be caused by trapped air, low water level, or the pump being too close to the walls of the fountain. While the pump is fully submerged, try gently tapping the pump with your finger to help release the trapped air. Also, check if adding water or moving the pump helps to reduce noise.
- Make sure the AC adapter is fully connected to the pump power cable. If the lights are not working, ensure the cables are fully connected, and the seals are adequately tightened (do not over-tighten).
- Check to make sure the power outlet is working; consult a certified electrician if in doubt about electrical connections.

*If you experience issues with assembly, pump operation, or the product was damaged during shipping, please contact our customer service team through one of the methods mentioned at the top of page 1. Please have the item number and order information ready to expedite response time.*



## IMPORTANT SAFETY INFORMATION



- For outdoor use only.
- Keep fountain out of reach of children and pets.
- Prevent water loss and damage to electrical sockets by ensuring the power cord has a drip loop; a diagram of a drip loop is shown on the right.
- Make sure the power cord is away from traffic areas.
- Keep power cord away from all heat sources. Do not use electrical cords in areas with high temperatures.
- Check the water level frequently to ensure the pump remains fully submerged; never allow the pump to run dry as it will burn out the motor.
- Always unplug the power supply before cleaning and maintaining the fountain and the recirculating pump.
- Take care when handling the pump; only pick it up by the body of the pump, never by the power cord.

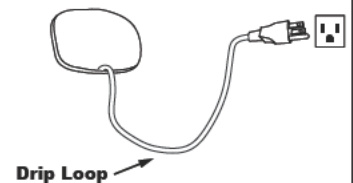

*Drawing is for visual reference only, cord placement and plug type vary by fountain style.*

**Any modification to the product or failure to follow recommended care will void the product warranty.**

## WARNING!

**Manufacturer and seller expressly disclaim any and all liability from personal injury, property damage or loss, whether direct or indirect, or incidental, resulting from the incorrect attachment, improper use, inadequate maintenance, or neglect of this product.**