







# Harrison Swivel Chair • 5125 • INSTRUCTIONS

Organize your parts and hardware before you begin.

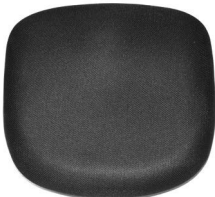

## Parts :

<b>A: Base</b>  <b>Quantity: 1</b>	<b>B: Back</b>  <b>Quantity: 1</b>	<b>C: Seat</b>  <b>Quantity: 1</b>	<b>D: Gas Cylinder</b>  <b>Quantity: 1</b>	<b>F: Arms (Left, Right)</b>  <b>Quantity: 2</b>
			<b>E: Casters</b>  <b>Quantity: 5</b>	

## Hardware :

<b>G: Allen Key</b>  <b>Quantity: 1</b>	<b>H: Long Bolts</b>  <b>Quantity: 6</b>	<b>I: Short Bolts</b>  <b>Quantity: 4</b>
--	---	--

## IMPORTANT NOTICE:

Place all wooden parts on a clean and smooth surface such as a rug or carpet to avoid the parts from being scratched.  
Check to be sure that you have all parts and hardware.  
Remove all wrapping materials, including staples & packing straps before you start to assemble.  
Do not tighten all screws/bolts until completely assembled.  
Keep all hardware and packaging out of reach of children.

Any problems or questions call Regency Office Furniture at 1-866-816-9822

## Harrison Swivel Chair • 5125 • INSTRUCTIONS

**STEP 1A:** Insert 5 Casters(E) into Base(A) (figure 1).

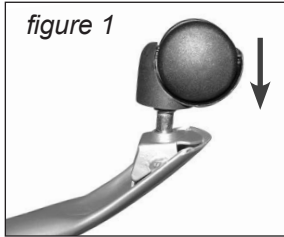
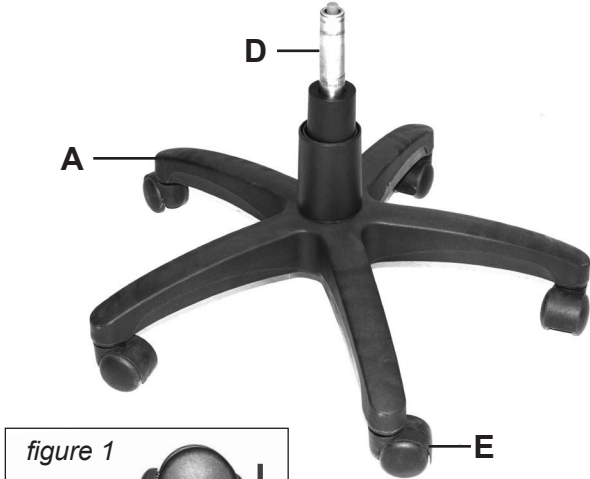

**STEP 1B:** Slide Gas Cylinder(D) into Base(A).

**STEP 2:** Attach the Back(B) to the bottom of Seat(C) using 4 Short Bolts(I).

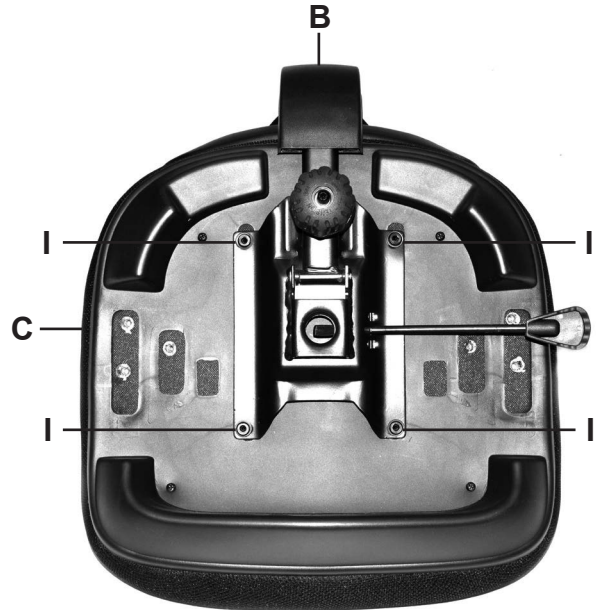

**STEP 3:** Attach the Arms(F) to the bottom of Seat(C) using 3 Long Bolts(H) per arm.

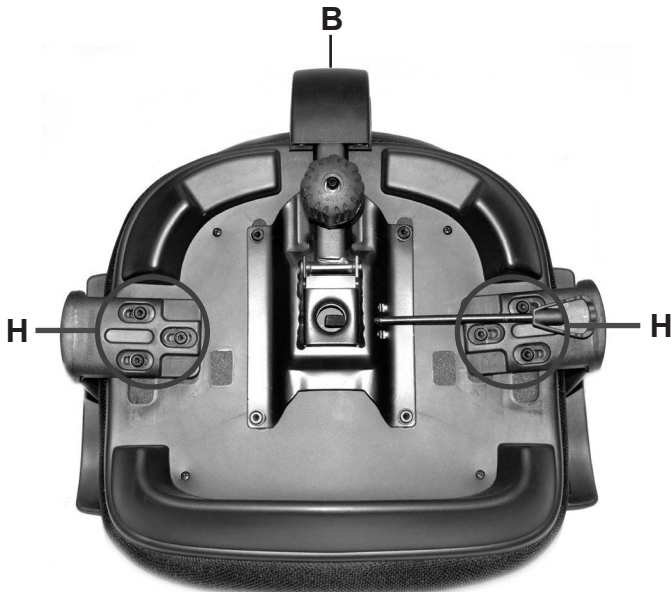

**STEP 4:** Place assembled Seat/Back onto Gas Cylinder(D) of Chair Base.

*NOTE: APPLY PRESSURE TO THE SEAT TO ENSURE CONNECTION BEFORE USE.*

