

80163/80058-511/512/513 QB ASSEMBLY INSTRUCTION

Thank you for purchasing this quality product. Be sure to check all packing material carefully for small parts which may have come loose inside the carton during shipment. Separate, identify and count all parts and hardware. Compare with the parts list to be sure all parts are present.

IMPORTANT : PLEASE READ INSTRUCTION BEFORE STARTING THE ASSEMBLY.

"DO NOT TIGHTEN SCREWS UNTIL COMPLETELY ASSEMBLED"

"DO NOT OVERTIGHT ANY HARDWARE"

WARNING : SMALL PARTS AND HARDWARE NOT FOR CHILDREN UNDER 3 YEARS. ADULT ASSEMBLY REQUIRED.

TABLE OF CONTENTS

HARDWARES LIST	PAGE 2 - 4
PARTS LIST	PAGE 5 - 7
PARTS' LOCATION	PAGE 8
ASSEMBLY STEPS	PAGE 9 - 21
ASSEMBLY COMPLETED	PAGE 21

ASSEMBLY TOOLS REQUIRED

1. Screwdriver (not provide)

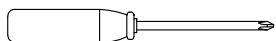

2. Hammer (not provide)

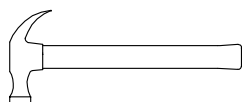

3. Rubber Hammer (not provide)

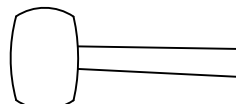



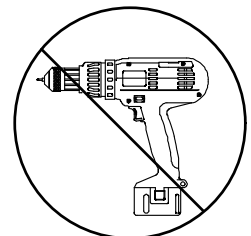



Skip the power drill this time.

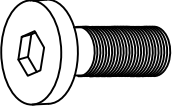
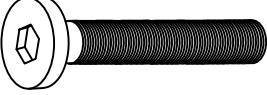

80163/80058-511/512/513 QB ASSEMBLY INSTRUCTION

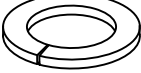
HARDWARES LIST (SECTION A)

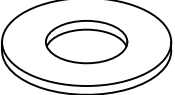

ITEM	DESCRIPTION	DRAWING	QTY
A	MINIFIX CAM LOCK		16 PCS
B	MINIFIX CAM BOLT		16 PCS
C	WOOD DOWEL (M8 x 30MM)		16 PCS
D	JCBB SCREW M8 x 16MM		4 PCS
F	JCBC SCREW M6 x 45MM		9 PCS
H	SPRING WASHER M6 x 13MM (SMALL)		9 PCS
I	SPRING WASHER M8 x 14MM (BIG)		4 PCS
J	FLAT WASHER M6 x 19MM (SMALL)		9 PCS
K	FLAT WASHER M8 x 22MM (BIG)		4 PCS

80163/80058-511/512/513 QB ASSEMBLY INSTRUCTION

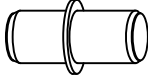
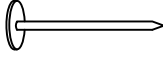
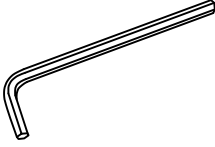
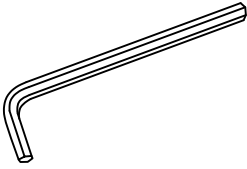
HARDWARES LIST (SECTION A)

ITEM	DESCRIPTION	DRAWING	QTY
N	SHELF SUPPORT (M5 x 16mm)		12 PCS
R	6/8" NAIL		28 PCS
T	M4 ALLEN KEY (65MM)		1 PC
U	M5 ALLEN KEY (65MM)		1 PC

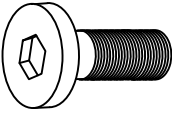
HARDWARES LIST (SECTION C)

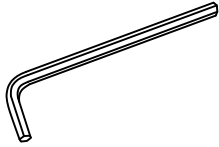

ITEM	DESCRIPTION	DRAWING	QTY
D	JCBB SCREW M8 x 16MM		8 PCS
G	JCBC SCREW M6 x 50MM		3 PCS
M	CSK C/B SCREW (M4 x 32MM)		6 PCS
T	M4 ALLEN KEY (65MM)		1 PC

80163/80058-511/512/513 QB ASSEMBLY INSTRUCTION

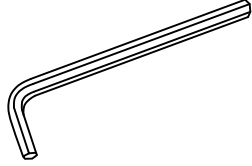
HARDWARES LIST (SECTION C)



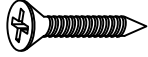
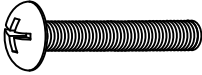
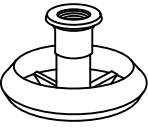
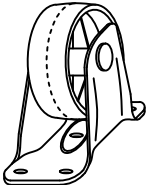

ITEM	DESCRIPTION	DRAWING	QTY
U	M5 ALLEN KEY (65MM)		1 PC

HARDWARES LIST (SECTION D)

ITEM	DESCRIPTION	DRAWING	QTY
A	MINIFIX CAM LOCK		16 PCS
B	MINIFIX CAM BOLT		16 PCS
C	WOOD DOWEL (M8 x 30MM)		16 PCS
L	CSK C/B SCREW (M4 x 16MM)		32 PCS
P	TRUSS M-SCREW (20MM)		4 PCS
Q	HANDLE		4 PCS
S	CASTER		8 PCS

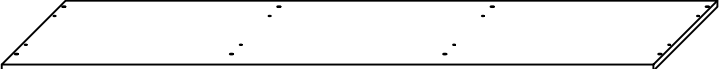
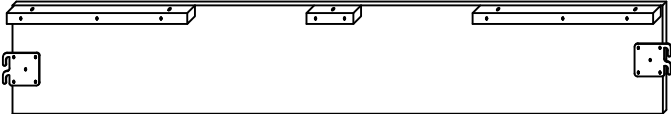

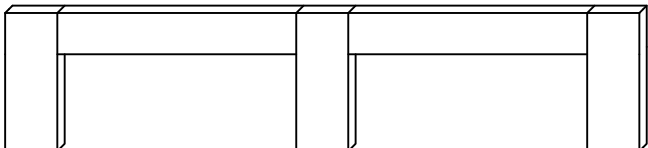
80163/80058-511/512/513 QB ASSEMBLY INSTRUCTION

PARTS LIST (BOX 1)

ITEM	DESCRIPTION	DRAWING	QTY
1	HEADBOARD BOX TOP PANEL		1 PC
6	HEADBOARD BOX BOTTOM PANEL		1 PC
9	HEADBOARD MIDDLE SUPPORT PANEL		1 PC
10	BACK PANEL		1 PC
11	FOOTBOARD		1 PC
16	DRAWER HEAD		2 PCS
22	TOP FRAME		1 PC

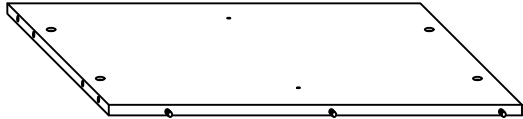
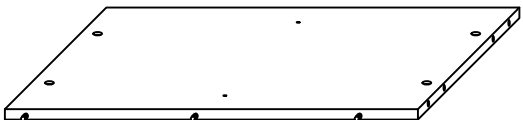
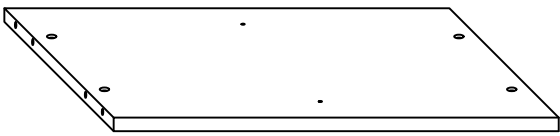
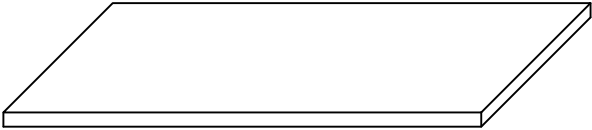
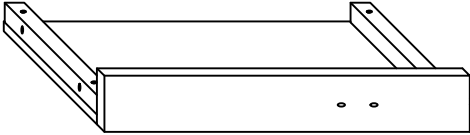
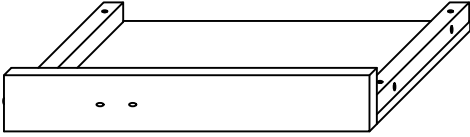

80163/80058-511/512/513 QB ASSEMBLY INSTRUCTION

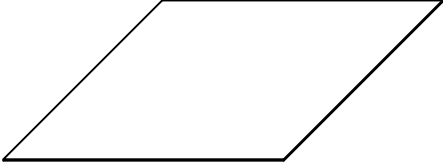
PARTS LIST (BOX 2)

ITEM	DESCRIPTION	DRAWING	QTY
2	HEADBOARD BOX LEFT PANEL (L)		1 PC
3	HEADBOARD BOX RIGHT PANEL (R)		1 PC
4	HEADBOARD BOX INSIDE PANEL		2 PCS
5	HEADBOARD BOX COMPARTMENT PANEL		3 PCS
7	LEFT HEADBOARD LEG (L)		1 PC
8	RIGHT HEADBOARD LEG (R)		1 PC
17	DRAWER BACK PANEL		2 PCS
18	DRAWER BOTTOM PANEL		2 PCS

80163/80058-511/512/513 QB ASSEMBLY INSTRUCTION

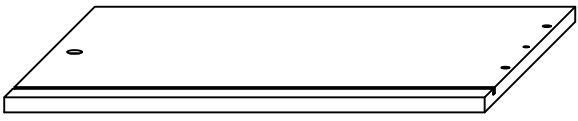
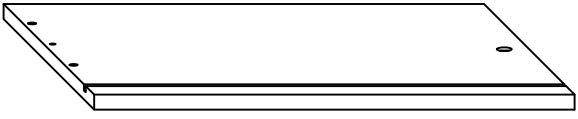
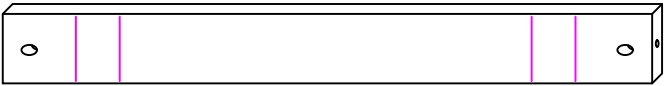
PARTS LIST (BOX 2)

ITEM	DESCRIPTION	DRAWING	QTY
19	DRAWER LEFT PANEL		2 PCS
20	DRAWER RIGHT PANEL		2 PCS
21	DRAWER BOTTOM SUPPORT RAIL		4 PCS
23	SIDE FRAME		2 PCS

PARTS LIST (BOX 3)

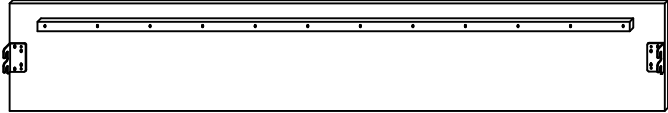
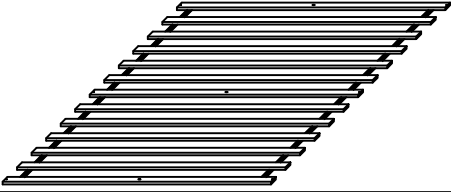
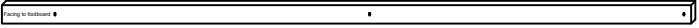
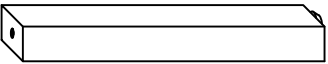
ITEM	DESCRIPTION	DRAWING	QTY
12	SIDE RAIL		2 PCS
13	SLAT (13 PCS PER SET)		1 SET
14	SLAT SUPPORT RAIL		1 PC
15	CENTRE SUPPORT LEG		3 PCS

80163/80058-511/512/513 QB ASSEMBLY INSTRUCTION

PARTS ' LOCATION

BED x 1 PC

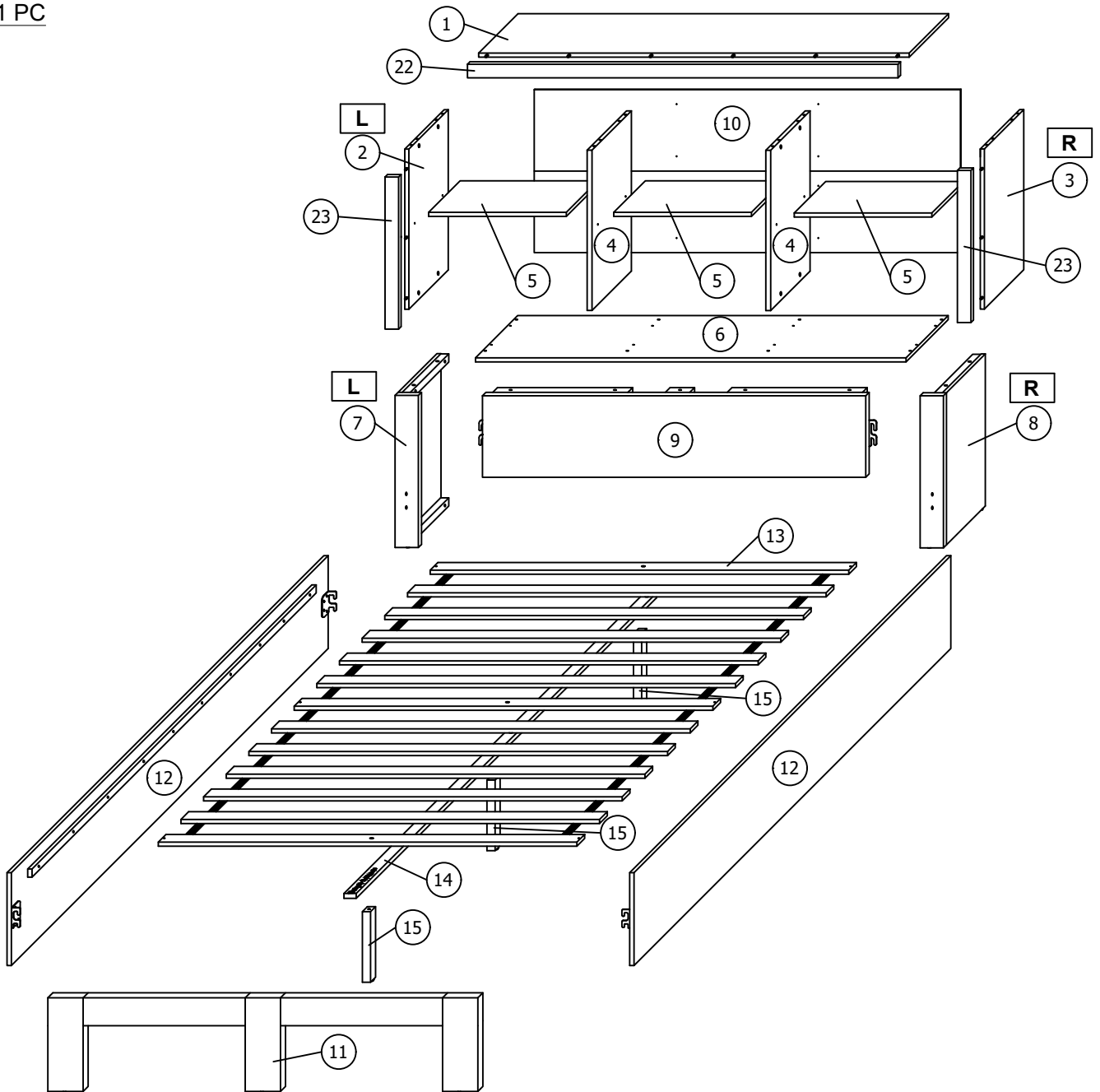

DRAWER x 2 PCS

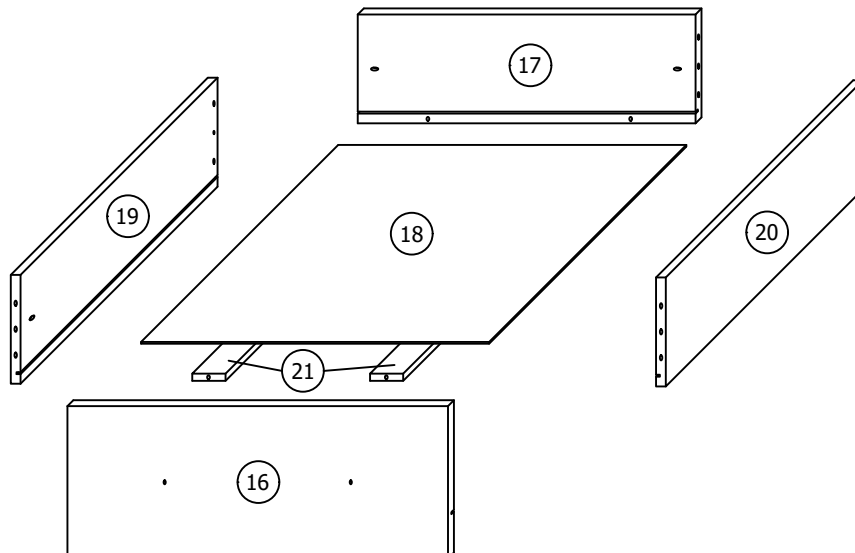

80163/80058-511/512/513 QB ASSEMBLY INSTRUCTION

ASSEMBLY STEPS

STEP 1

Connect (2),(23) then insert 4 pieces (A) and 2 pieces (N) to the (2) as shown.

****SECTION A HARDWARE FOR ASSEMBLY STEP 1 TO STEP 11**

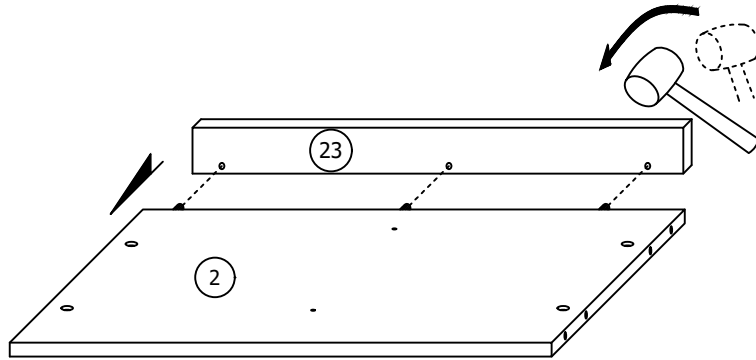

USE A RUBBER HAMMER.

Assembled looks

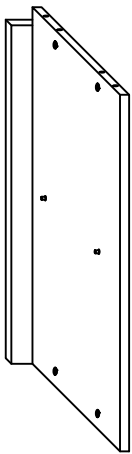

Arrow need to face outside.

Arrow need to face outside.

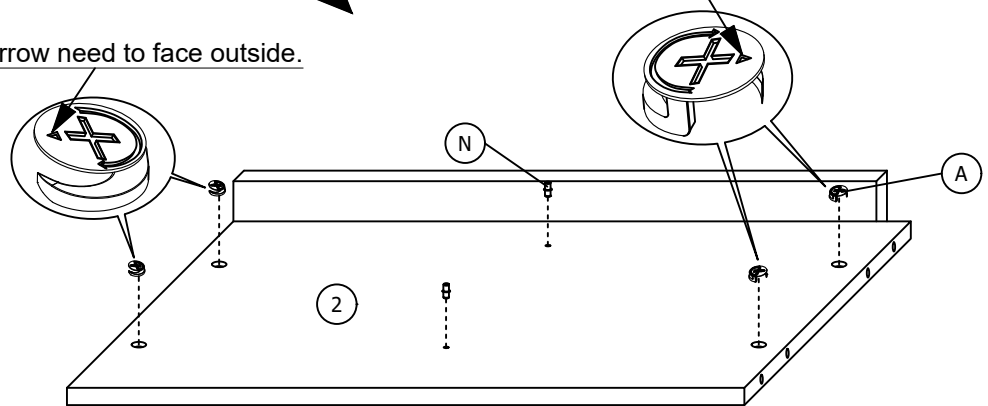

STEP 2

Connect (3),(23) then insert 4 pieces (A) and 2 pieces (N) to the (3) as shown.

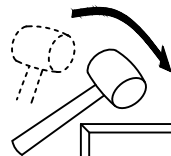

USE A RUBBER HAMMER.

Assembled looks

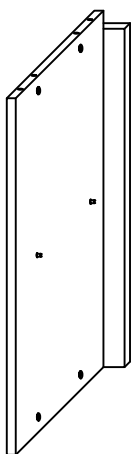

Arrow need to face outside.

Arrow need to face outside.

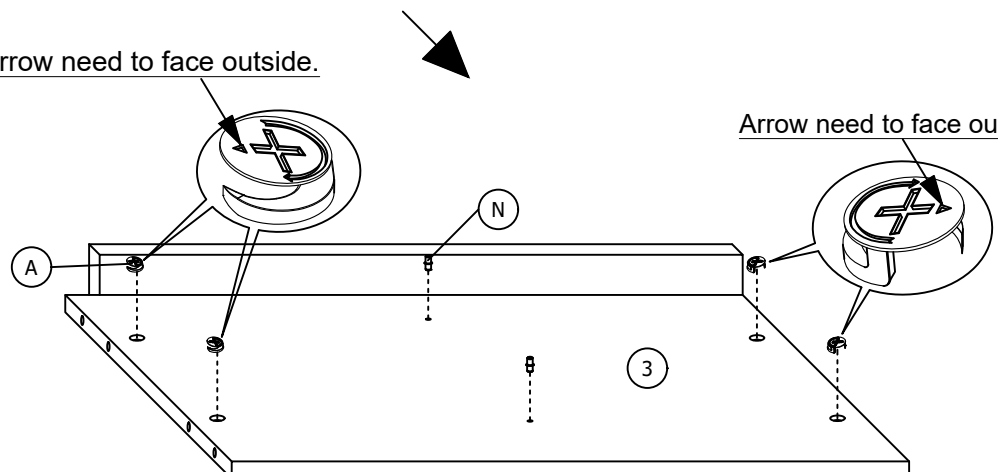

80163/80058-511/512/513 QB ASSEMBLY INSTRUCTION

STEP 3

Insert 4 pieces (A) and 2 pieces (N) to the one side of (4) , and 2 pieces (N) to another side as shown.

x 2

Arrow need to face outside.

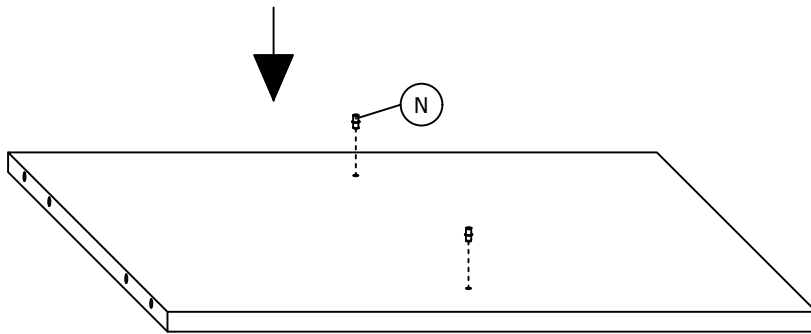
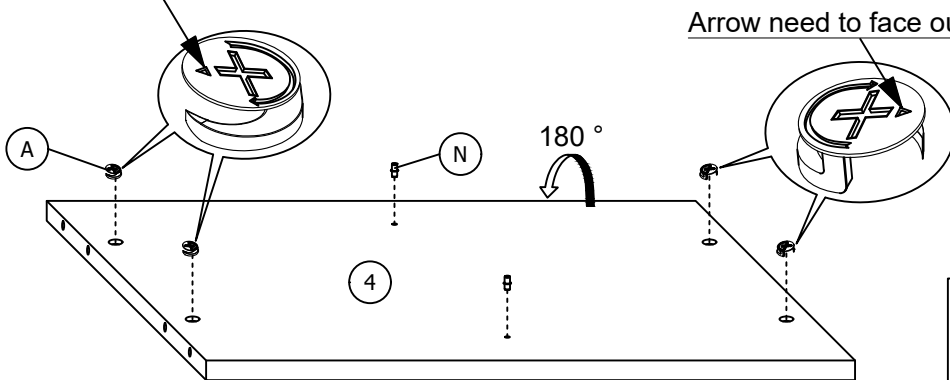

Assembled looks

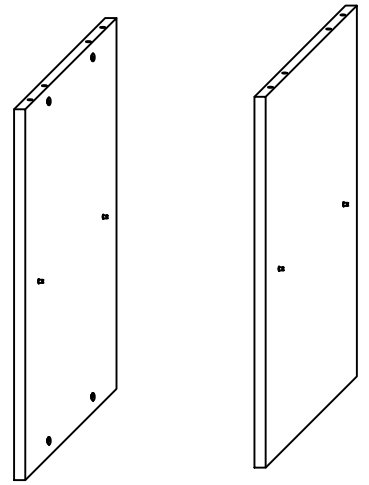

STEP 4

Insert 8 pieces (B) and (C) to the (6) as shown.

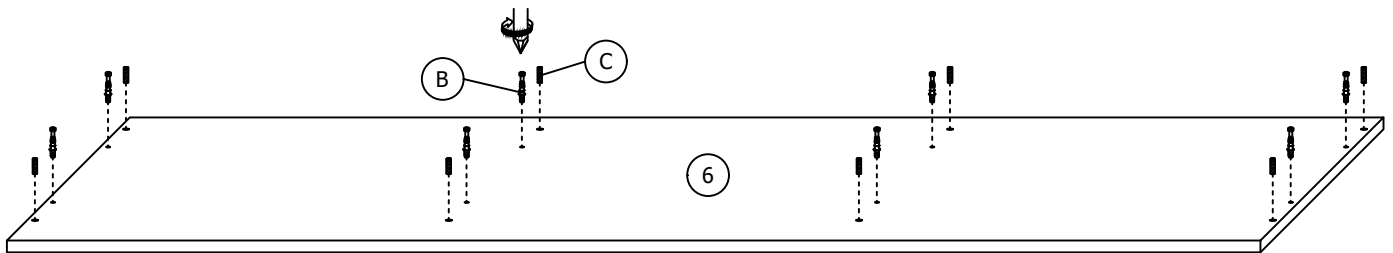

Assembled looks

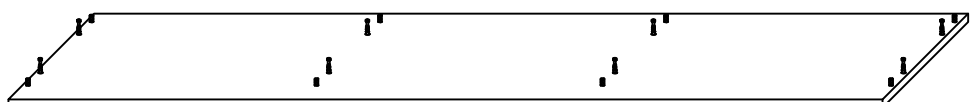

80163/80058-511/512/513 QB ASSEMBLY INSTRUCTION

STEP 5

Connect (1),(22) then insert 8 pieces (B) and (C) to the (1) as shown.

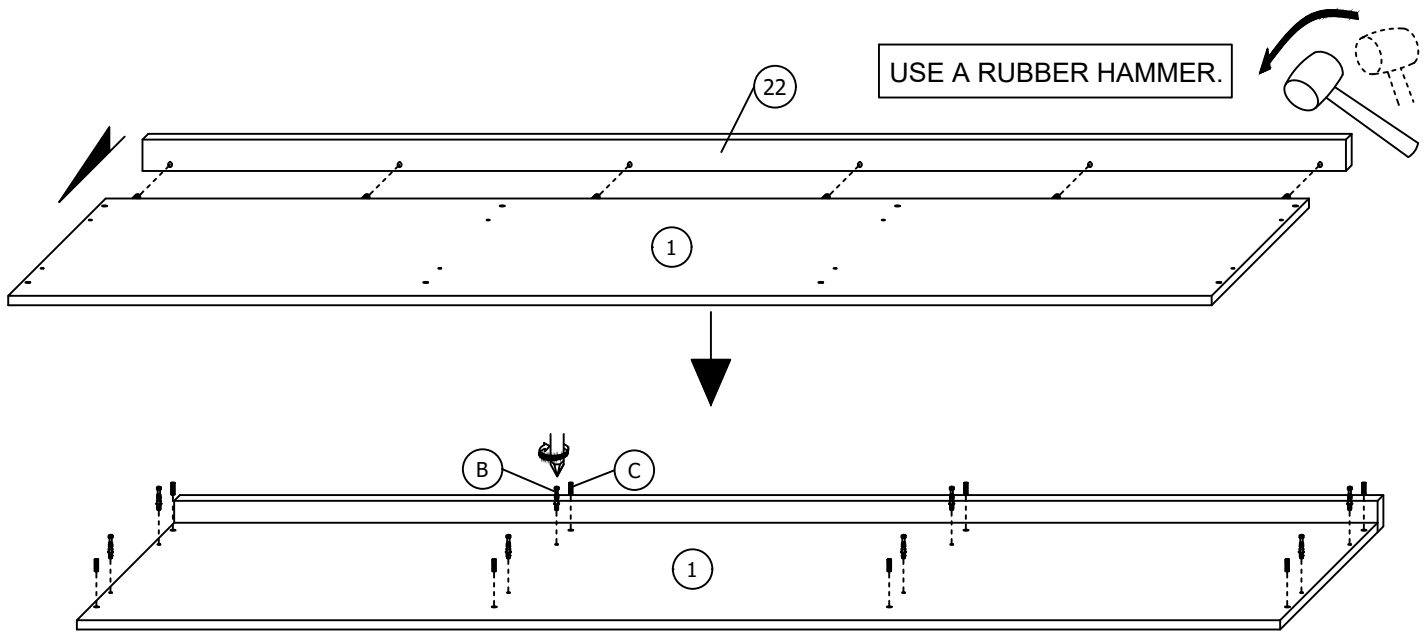

Assembled looks

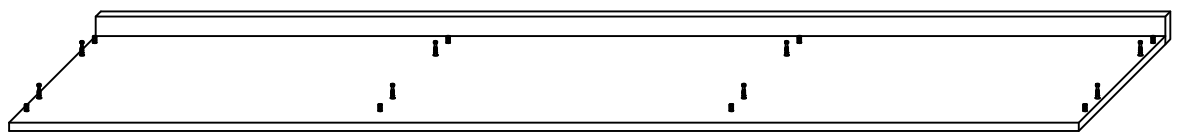

STEP 6

Combine the (2),(3) and (4) to the (6) then tighten the 8 pieces (A)-(pre insert in step 1 to 3) as shown.

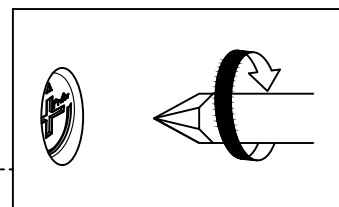
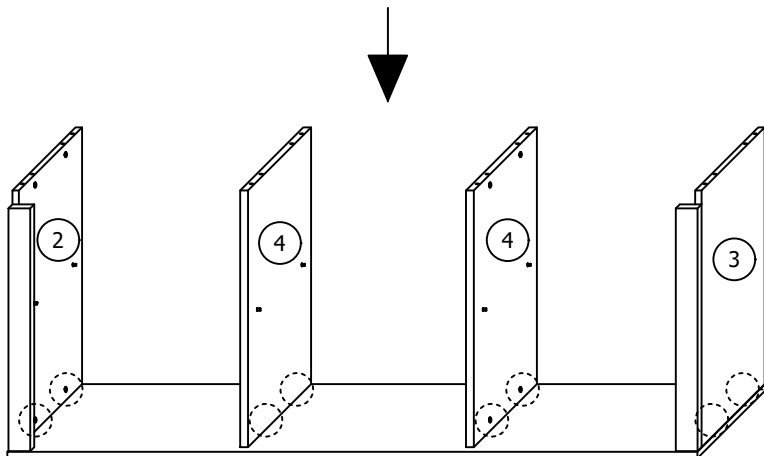
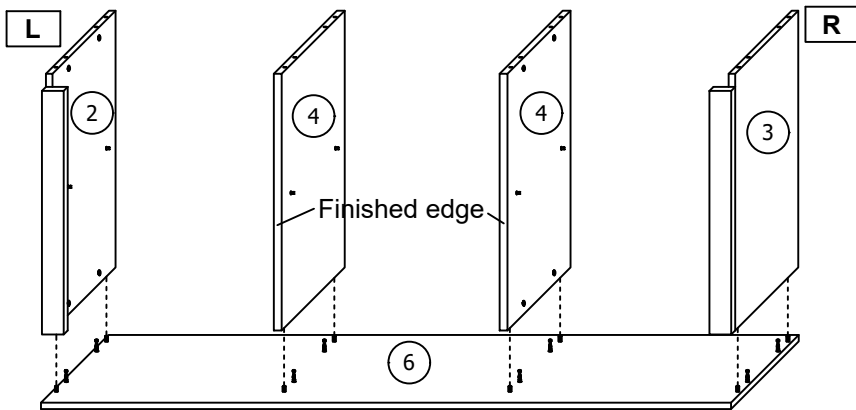

80163/80058-511/512/513 QB ASSEMBLY INSTRUCTION

STEP 7

Combine the (1) to the (2),(3) and (4) then tighten the another 8 pieces (A)-(pre insert in step 1 to 3) as shown.

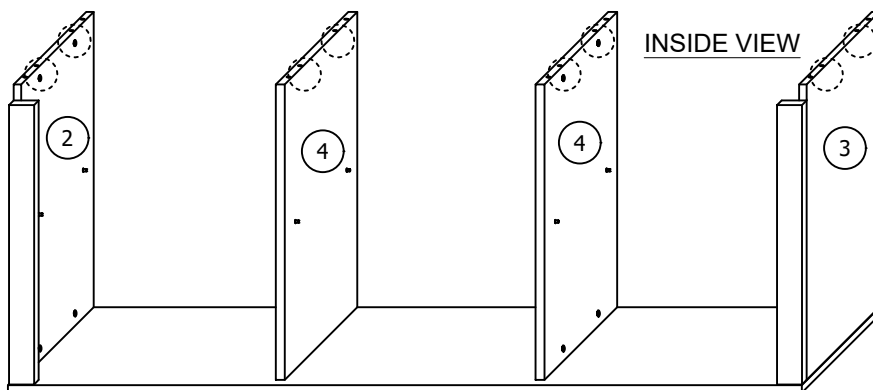
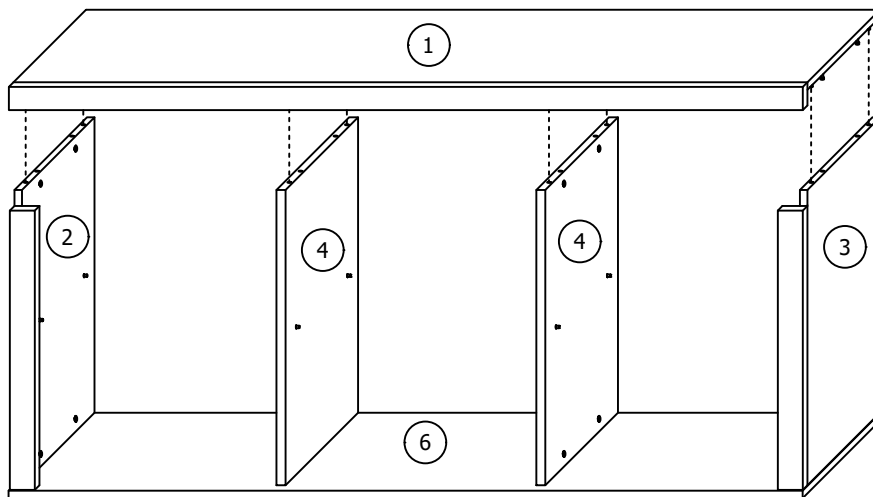

INSIDE VIEW

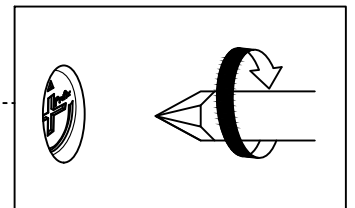

80163/80058-511/512/513 QB ASSEMBLY INSTRUCTION

STEP 8

Insert the 28 pieces (R) to fix the (10) as shown.

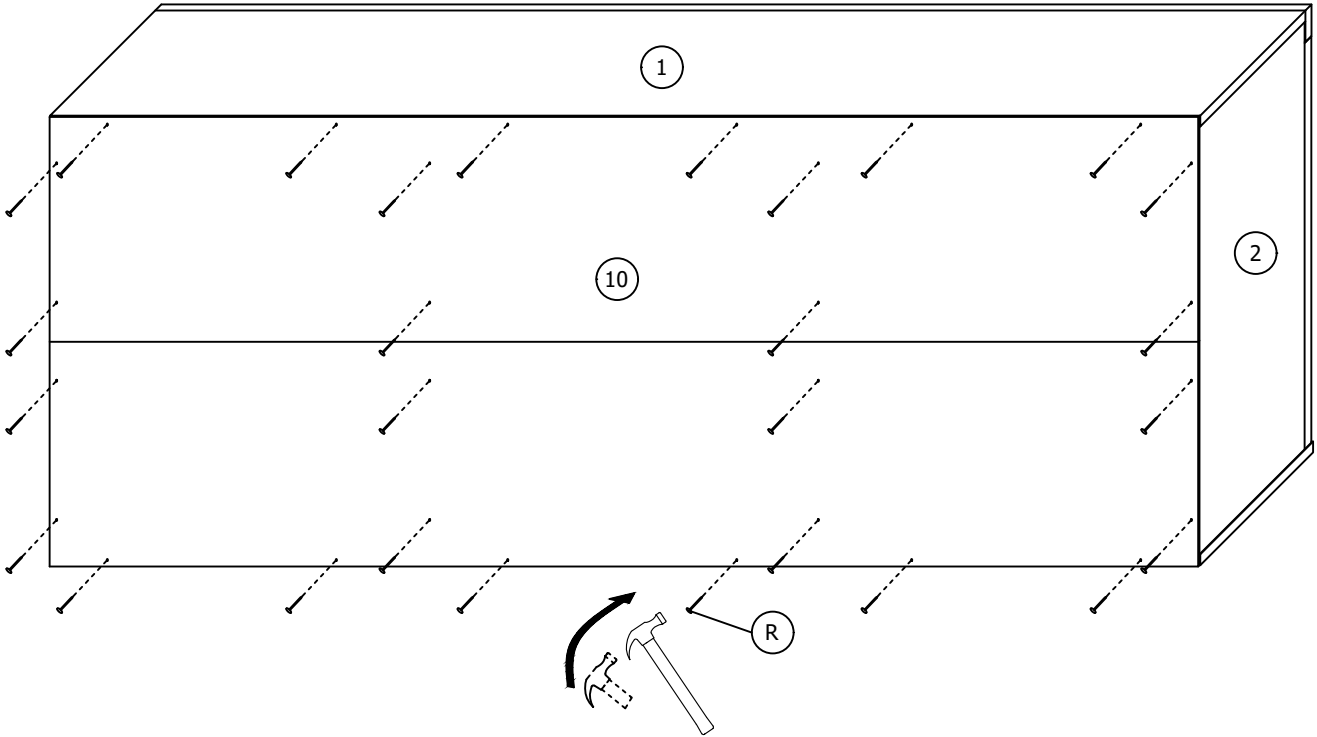

STEP 9

Insert 4 pieces (D),(I) and (K) to combine the (7),(8) and (9) as shown.

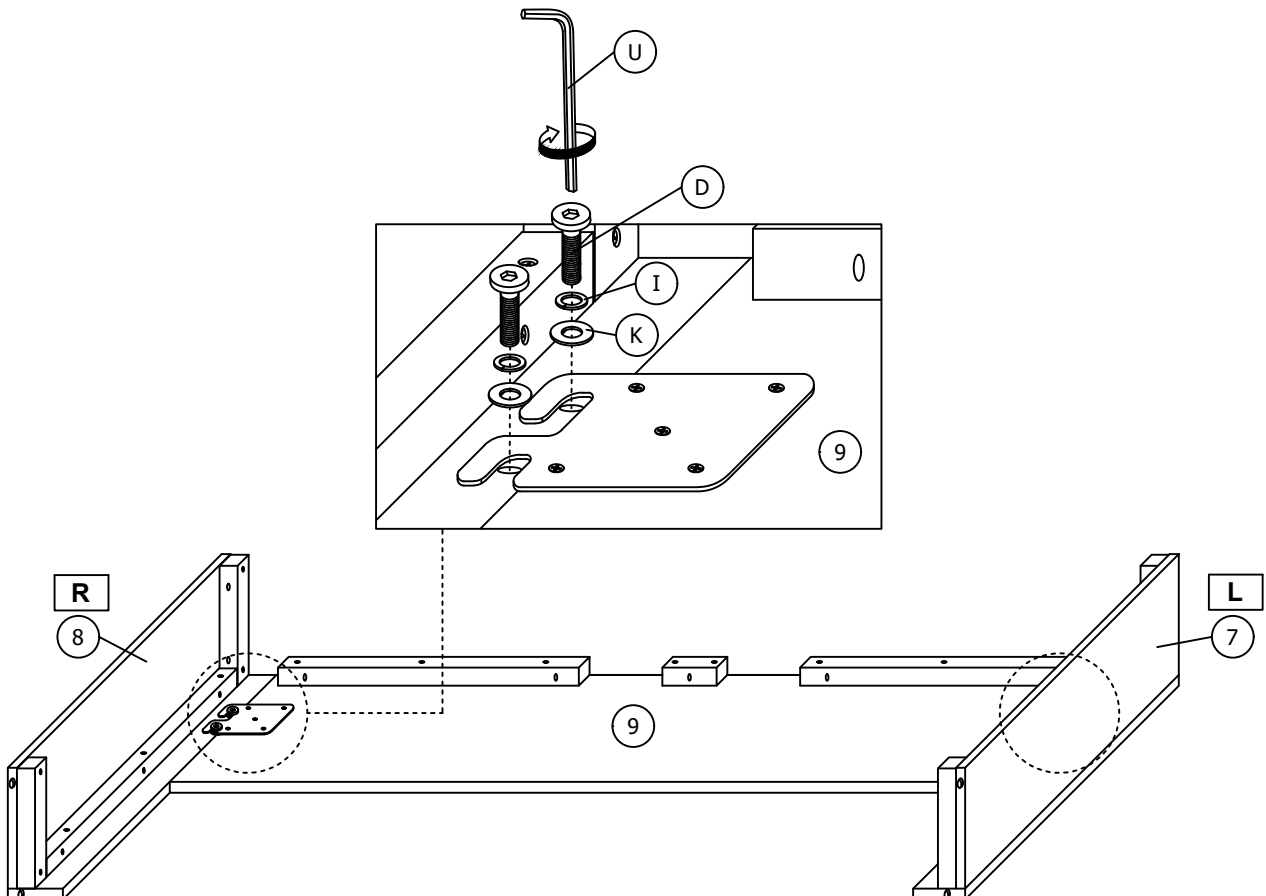

80163/80058-511/512/513 QB ASSEMBLY INSTRUCTION

STEP 10

Insert the 9 pieces (F),(H) and (J) to combine the (7),(8) and (9) to the (6) as shown.

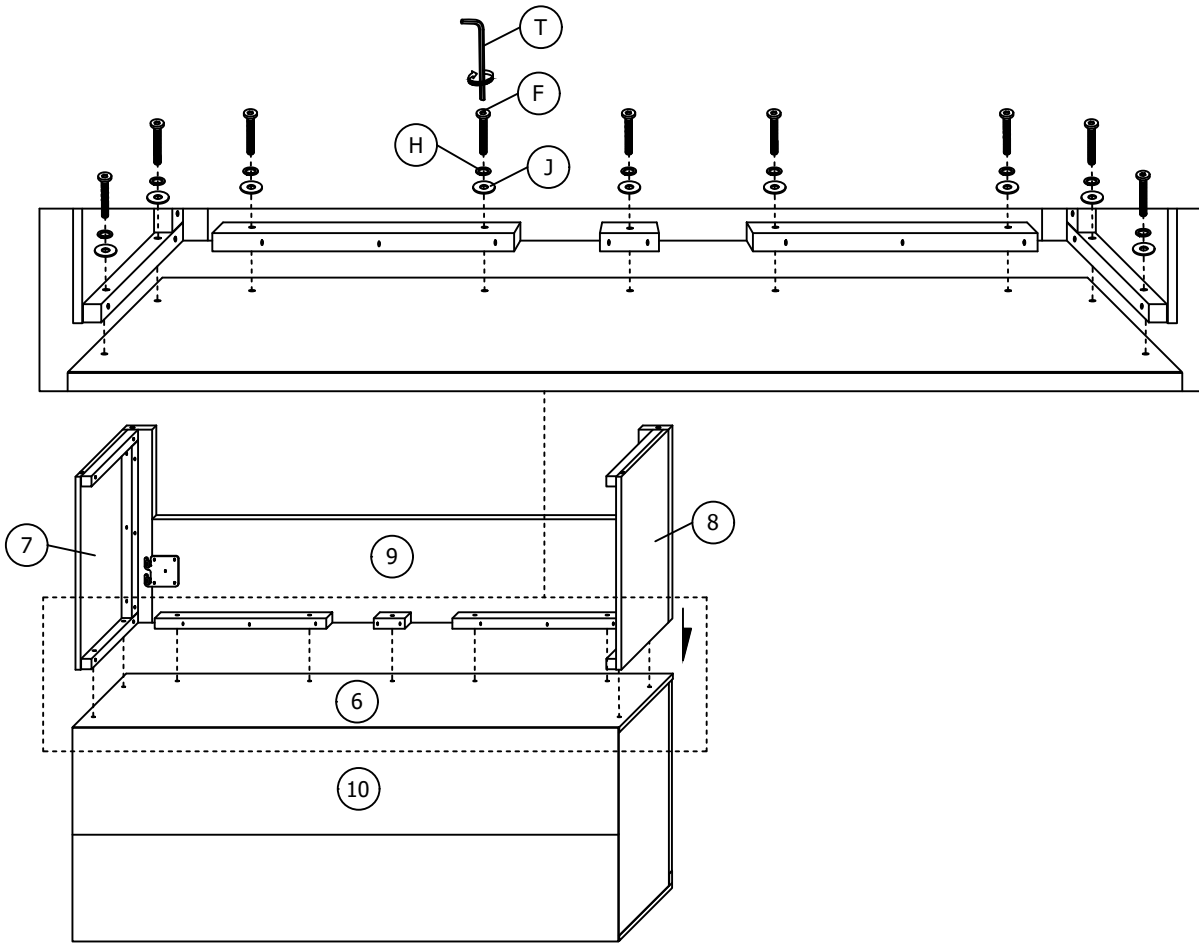

STEP 11

Put the (5) on the (N) which between (2),(3) and (4) as shown.

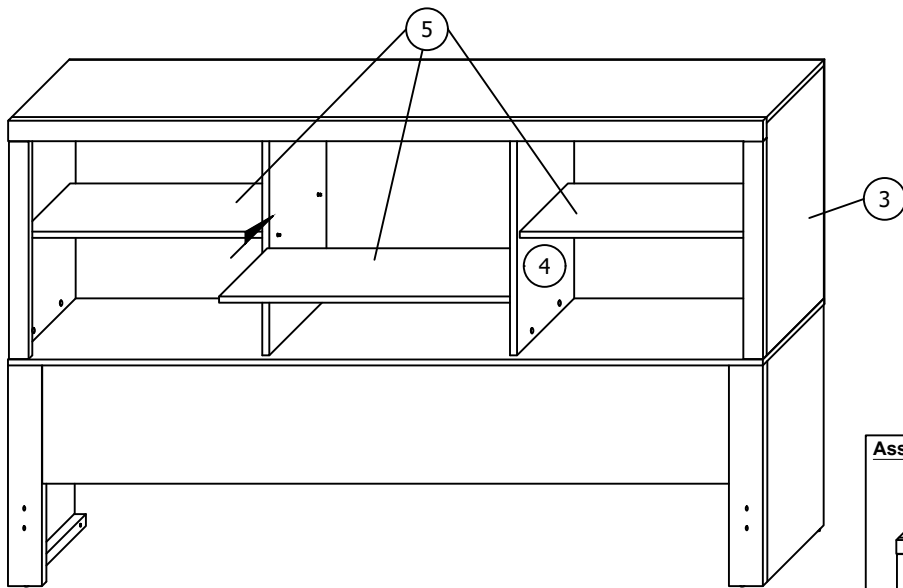

Assembled looks

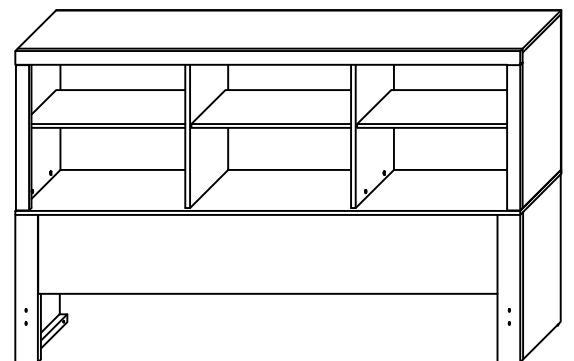

80163/80058-511/512/513 QB ASSEMBLY INSTRUCTION

STEP 12

Insert 4 pieces (B),(C) to the (16) as shown.

**SECTION D HARDWARE FOR ASSEMBLY STEP 12 TO STEP 21

x 2

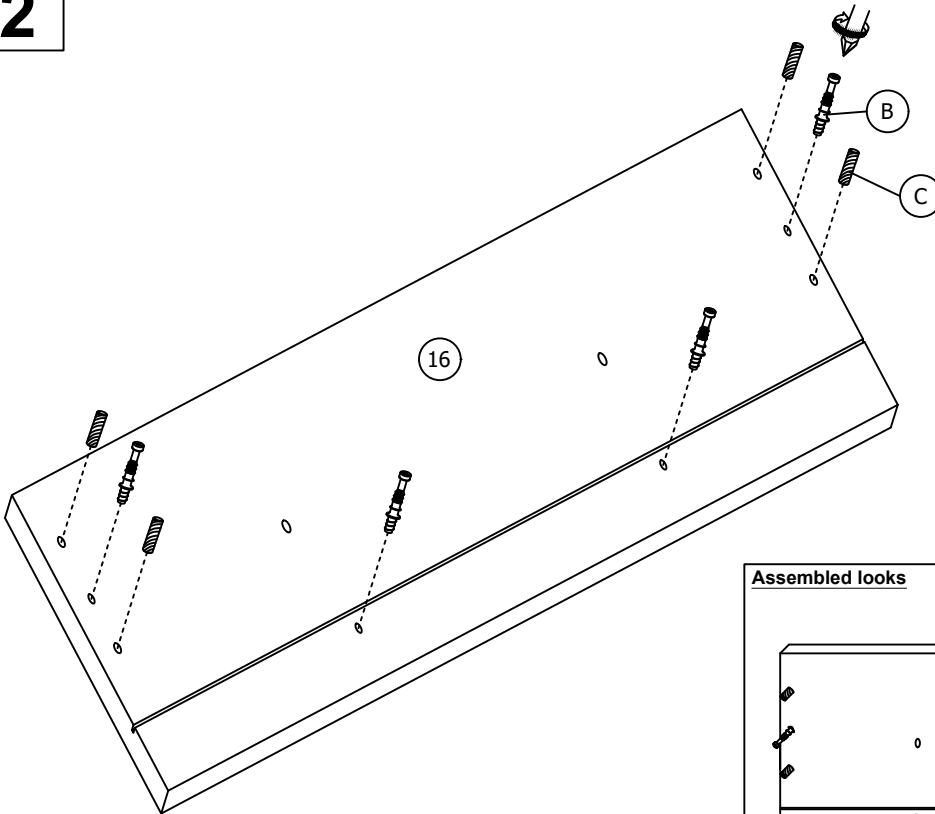

Assembled looks

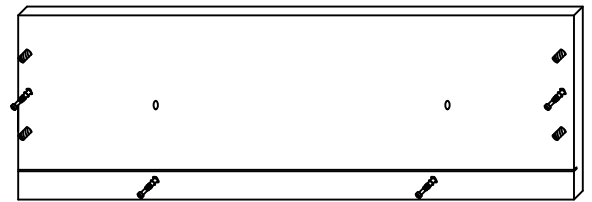

STEP 13

Insert 1 piece (A),(B) and 2 pieces (C) to (19) as shown.

x 2

Arrow need to face outside.

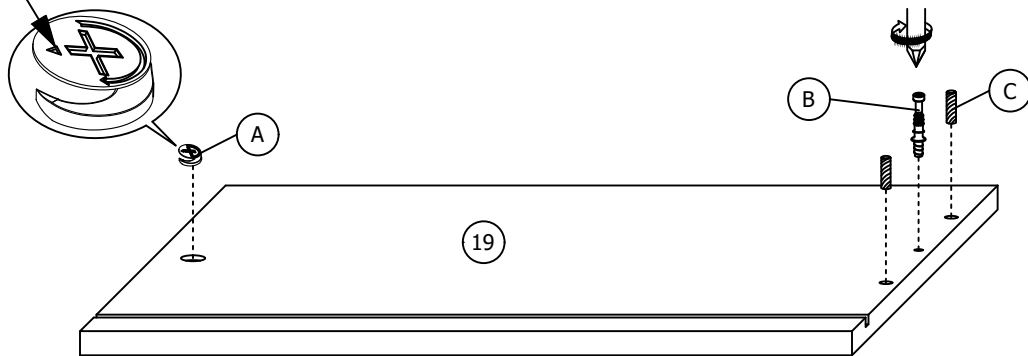

Assembled looks

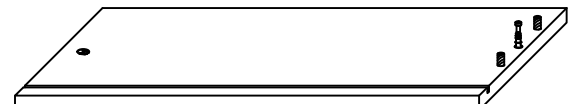

80163/80058-511/512/513 QB ASSEMBLY INSTRUCTION

STEP 14

Insert 1 piece (A),(B) and 2 pieces (C) to (20) as shown.

x 2

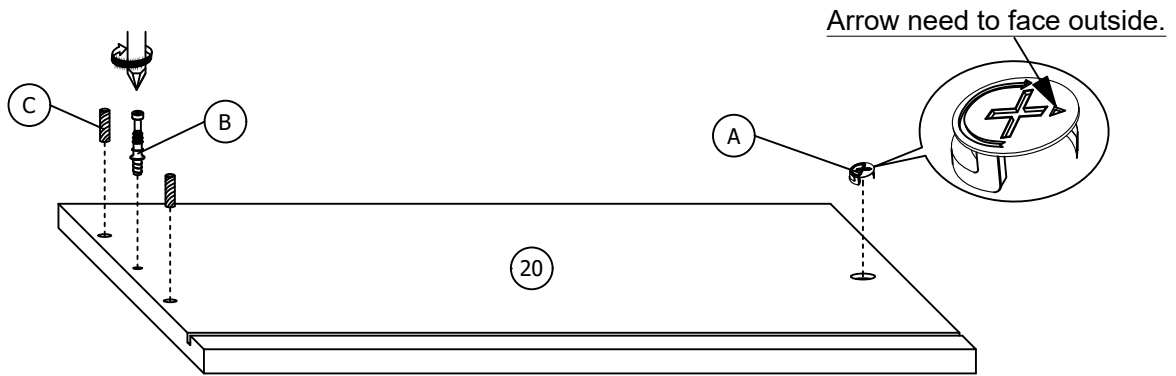

Assembled looks

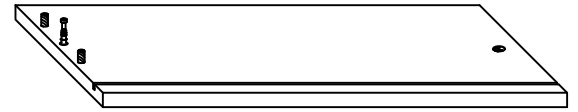

STEP 15

Insert 2 pieces (A),(B) to (17) as shown.

x 2

Arrow need to face outside.

Arrow need to face outside.

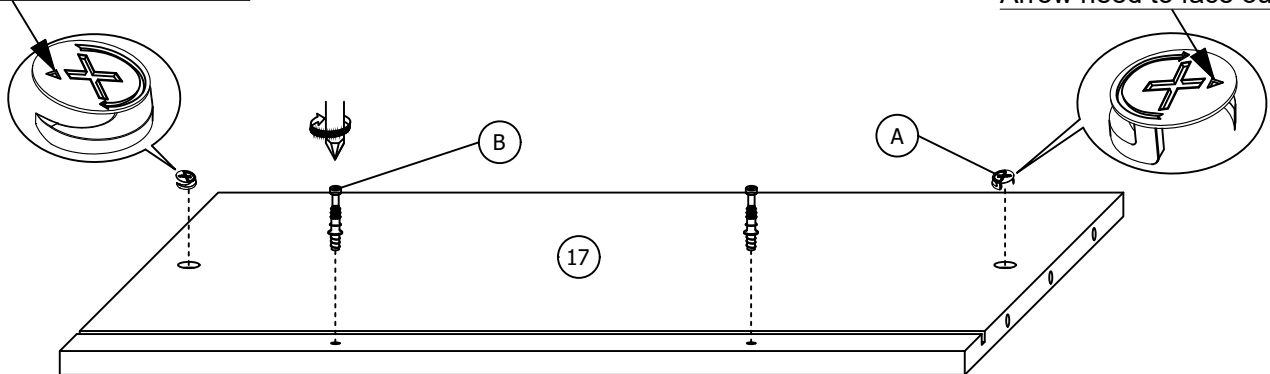

Assembled looks

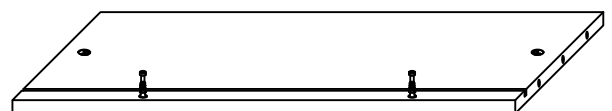

80163/80058-511/512/513 QB ASSEMBLY INSTRUCTION

STEP 16

Insert 2 pieces (A) to (21) as shown.

x 4

Arrow need to face outside.

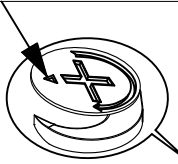

Arrow need to face outside.

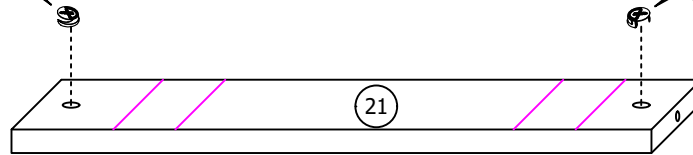

STEP 17

Combine (17),(19),(20) , then tighten the 2 pieces (A)-(pre-insert in step 15) as shown.

x 2

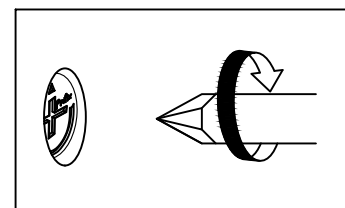
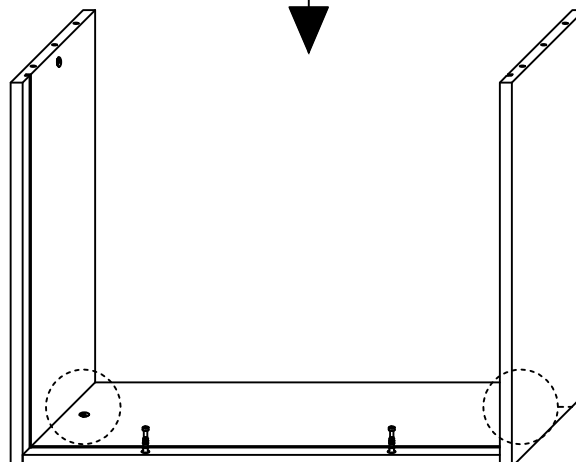
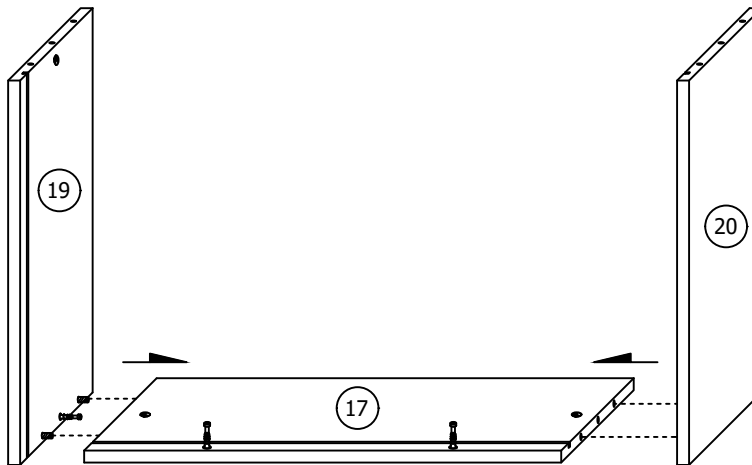

80163/80058-511/512/513 QB ASSEMBLY INSTRUCTION

STEP 18

Put (18) into the gap of (17),(19),(20) ,combine 2 pieces (21) to (17) then tighten the 2 pieces (A)-(pre-insert in step 16) as shown.

x 2

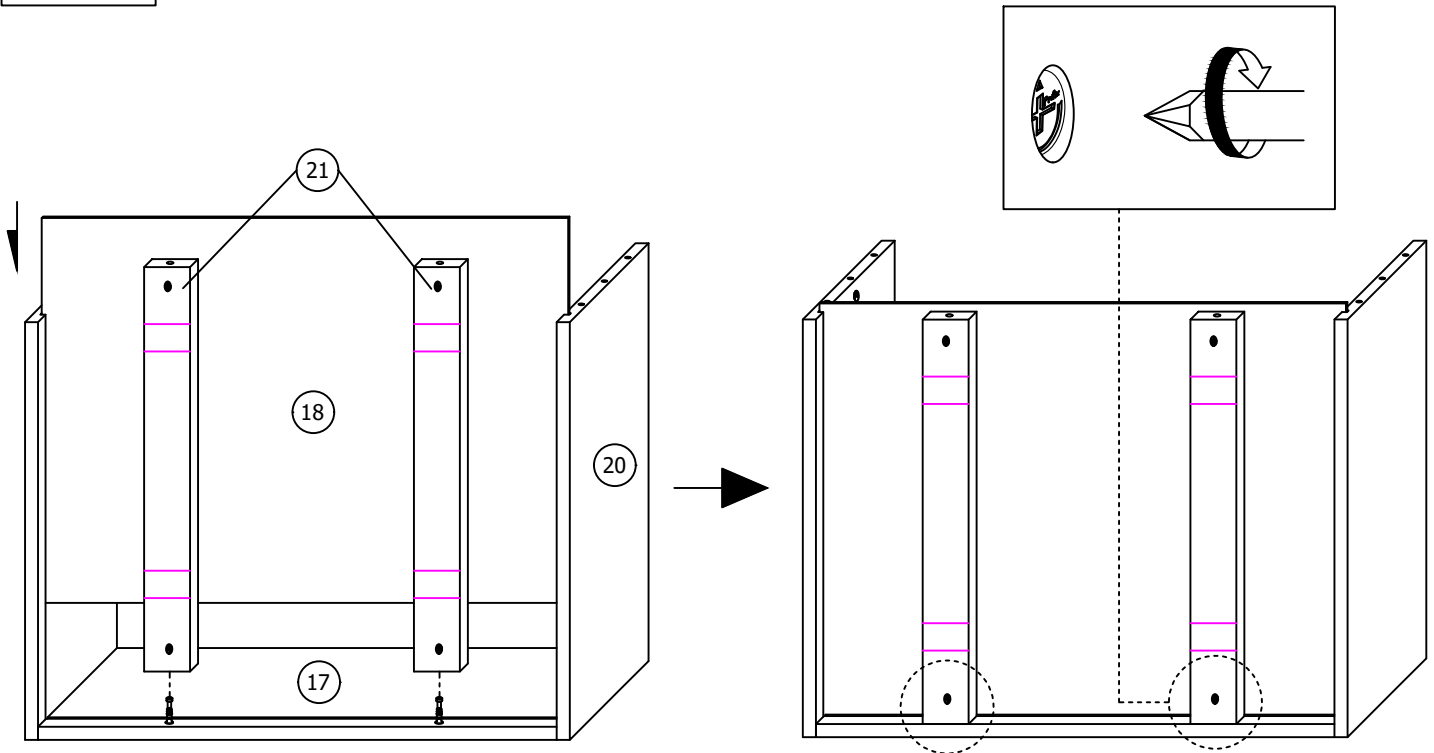

STEP 19

Combine (16) to the drawer box then tighten the 4 pieces (A)-(pre-insert in step 13,14 and 16) as shown.

x 2

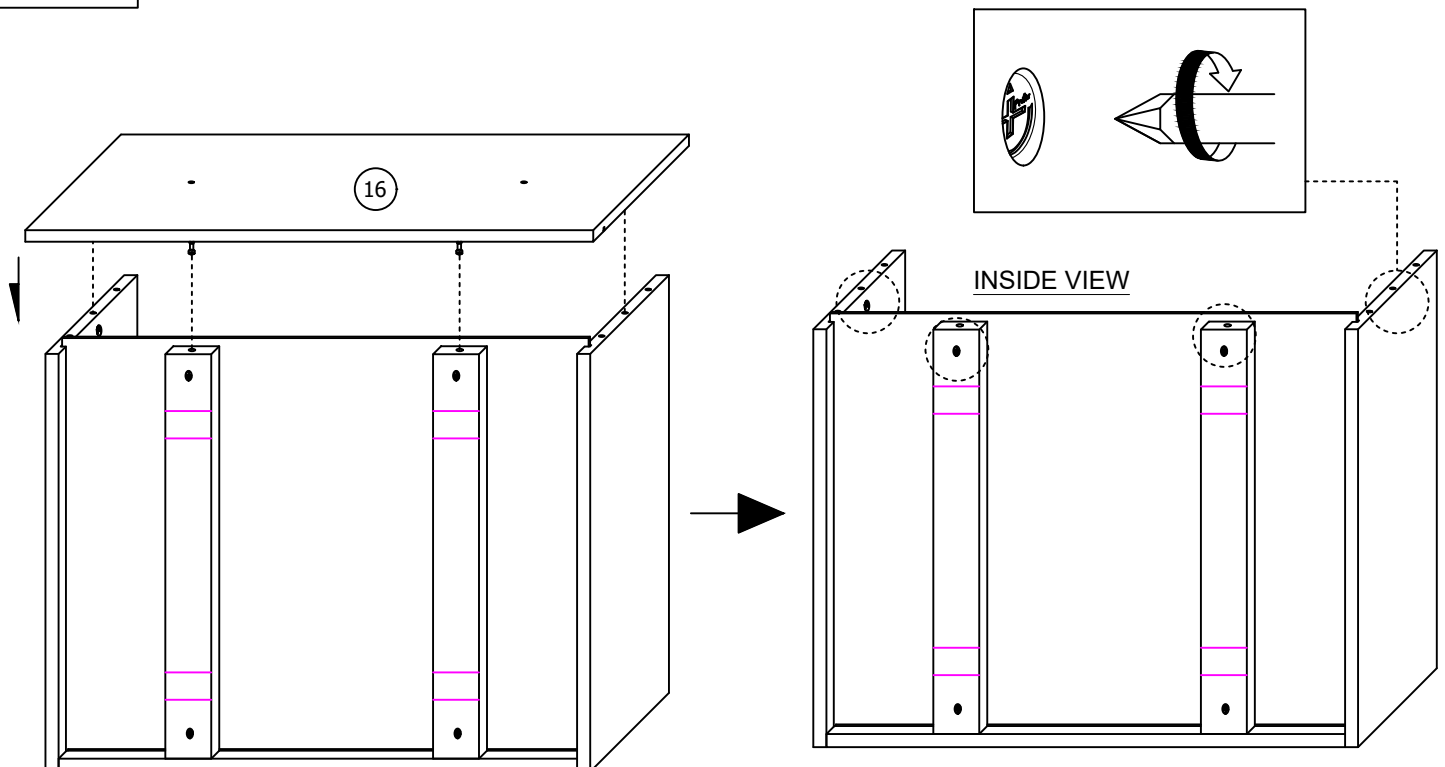

80163/80058-511/512/513 QB ASSEMBLY INSTRUCTION

STEP 20

Insert 16 pieces (L) to fix 4 pieces (S) to the (21) as shown.

x 2

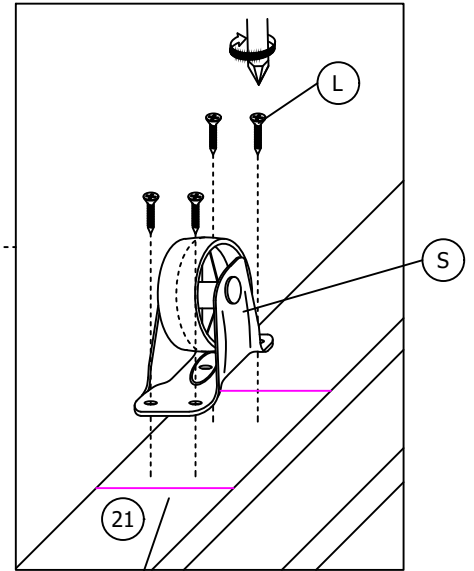
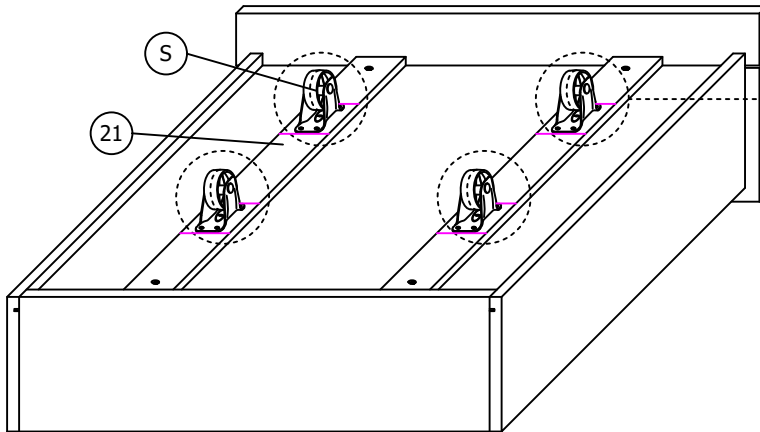

**Rotate 180 degrees after completed this step.

Place (S) in the line

STEP 21

Insert 2 pieces (P) fix the 2 pieces (Q) as shown.

x 2

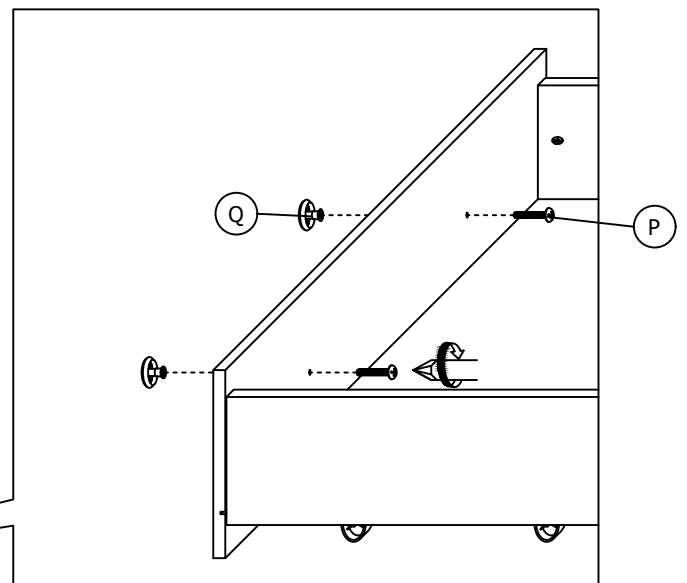
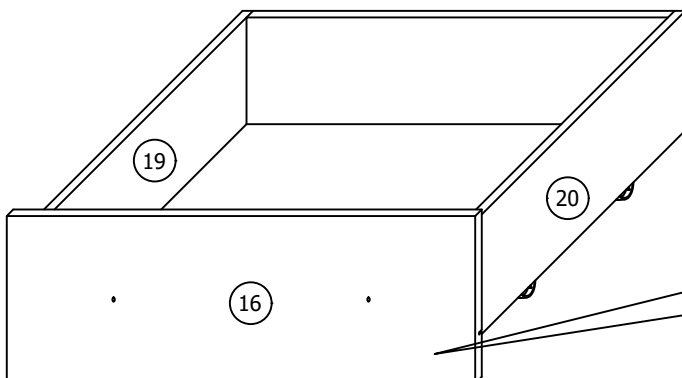

80163/80058-511/512/513 QB ASSEMBLY INSTRUCTION

STEP 22

Insert the 8 pieces (D) to combine the (7),(8),(11) and (12) as shown.

**SECTION C HARDWARE FOR ASSEMBLY STEP 22 TO STEP 24

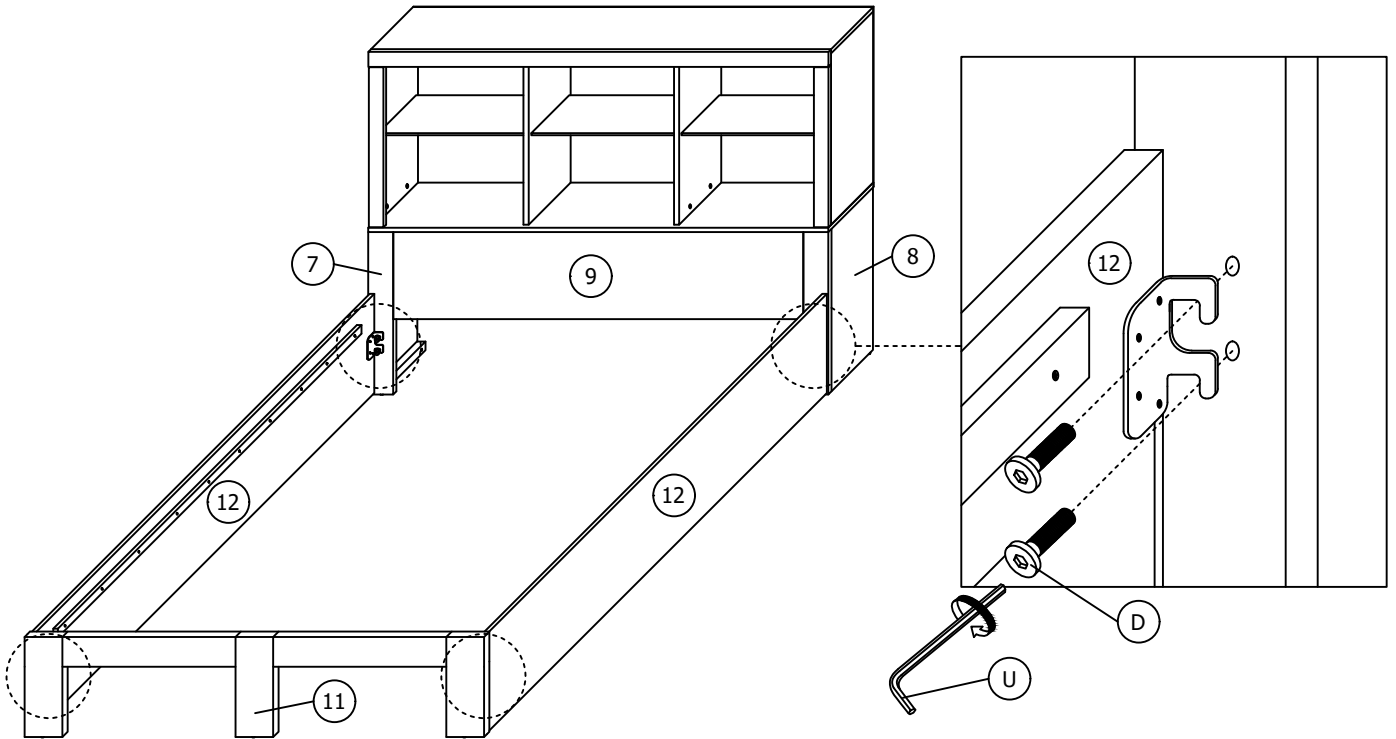

STEP 23

Insert 3 pieces (G) to combine the (13),(14) and (15) as shown.

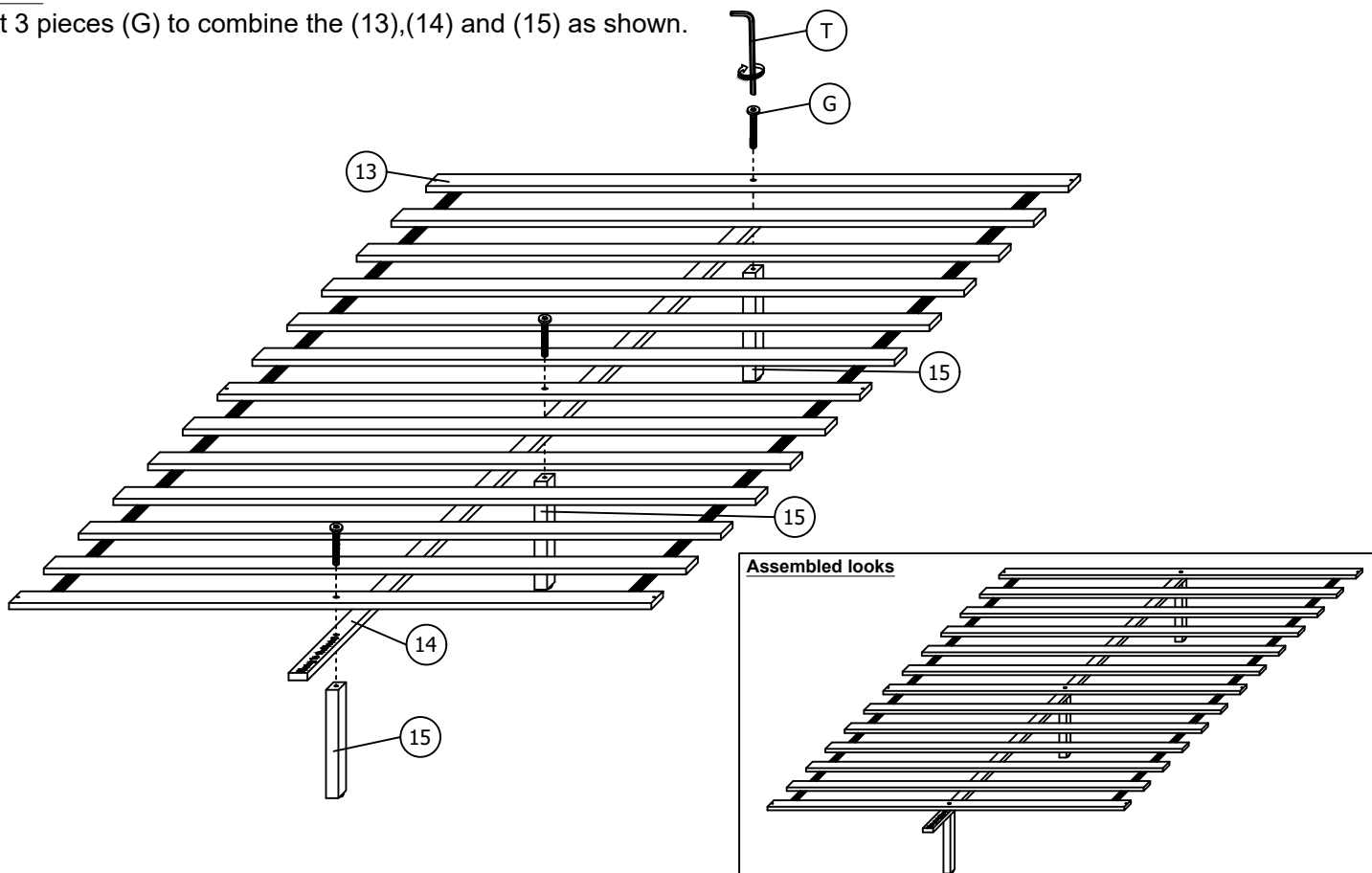

80163/80058-511/512/513 QB ASSEMBLY INSTRUCTION

STEP 24

Insert the 6 pieces (M) to fix the (13) on the wood of (12), then put the 2 pieces drawer inside exactly as shown.

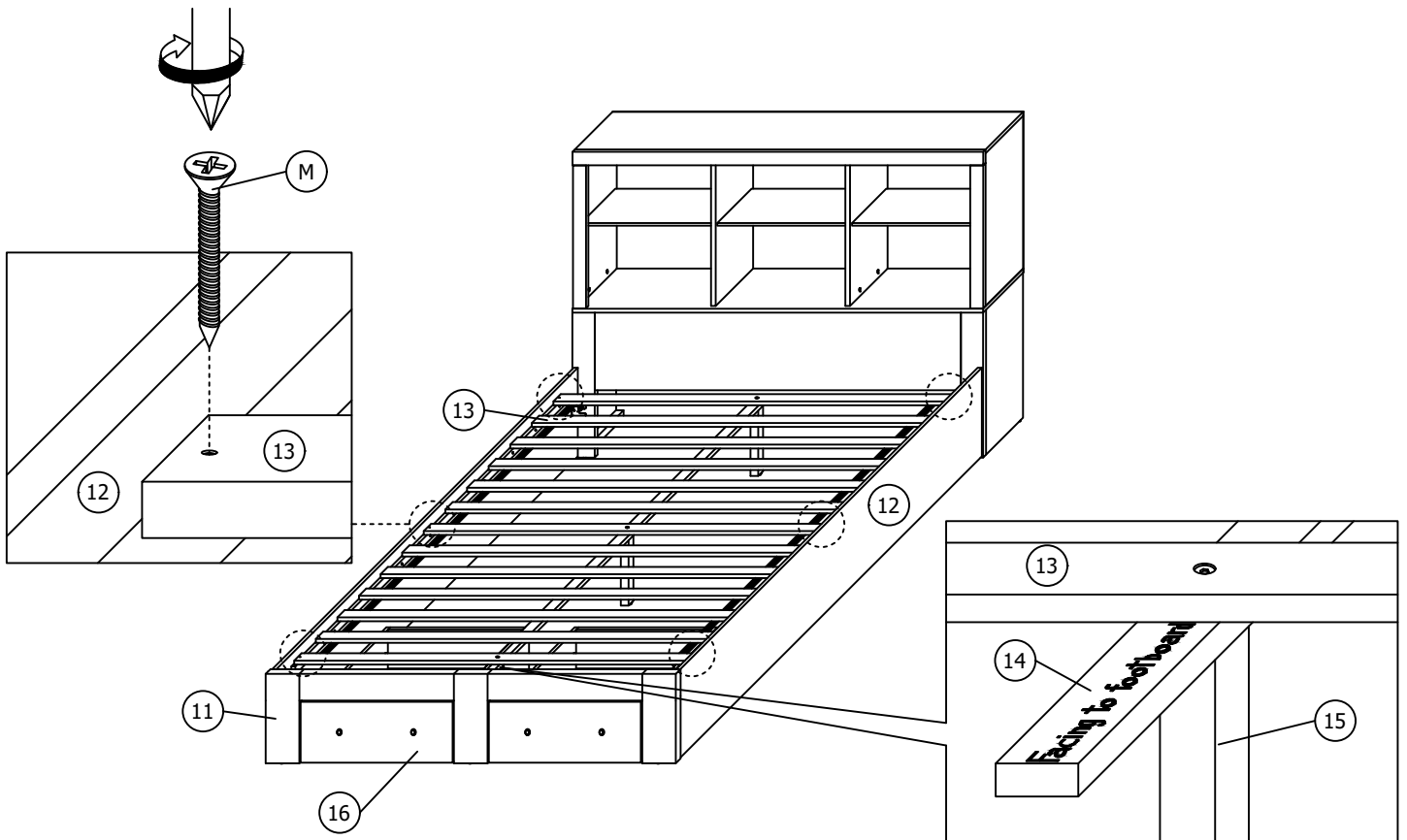

STEP 25

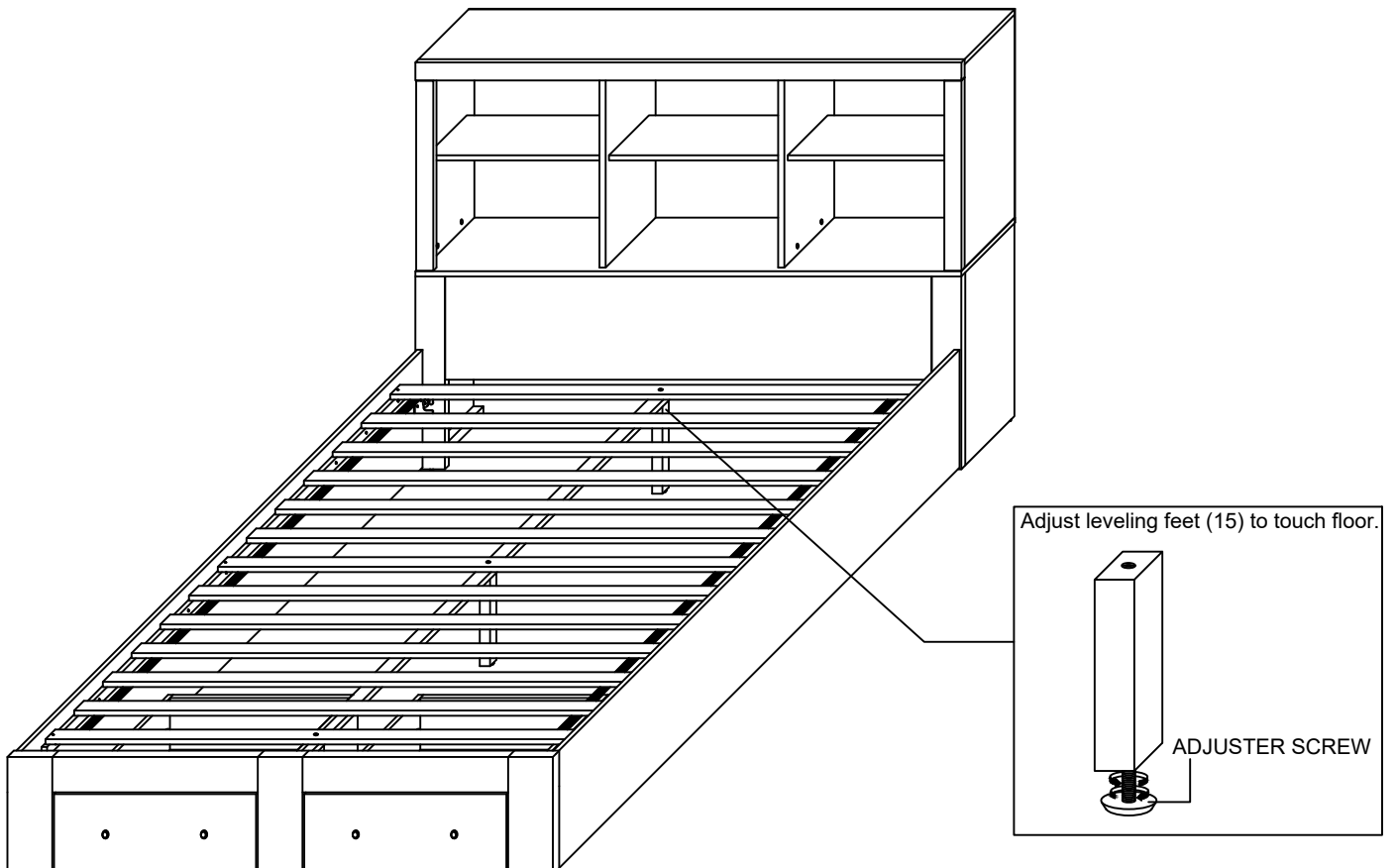

ASSEMBLY COMPLETED