

# Carpport

Assembly Instruction - Please keep properly for future reference.

If you find any missing boxes, damaged parts, or accessory shortages, please contact the customer service team of your purchasing channel immediately. We will resolve the issue as quickly as possible.

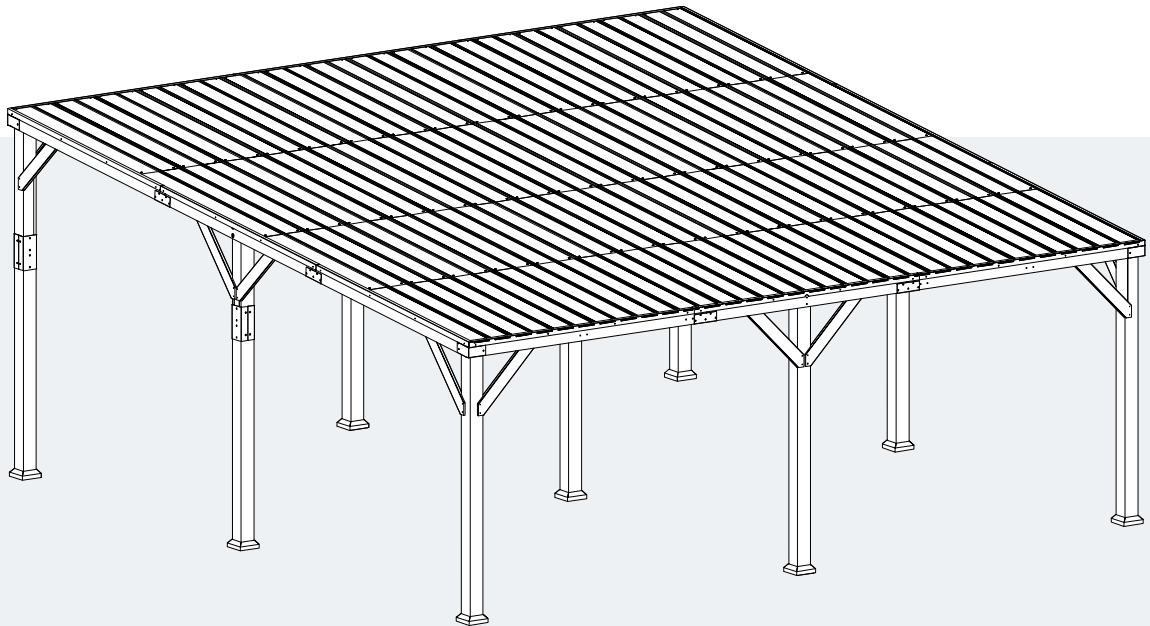

**20x20 FT**

## CONTACT US

- **Email: [service@grandtunnel.com](mailto:service@grandtunnel.com)**  
In order to receive assistance more quickly, please provide

## THE FOLLOWING INFORMATION:

- Order number
- Purchase platform
- Purchase date
- Detailed description of the issue along with photos (if applicable)

**Important** - Please read these instructions carefully before starting the installation.

**EN**

# Before Assembly



Thank you for choosing this product!

To ensure safe use and long-term maintenance, please read this manual carefully and keep it properly for future reference.

## Pre-installation Notes

1. Assembly requires five or more people.
2. It is recommended to use a ladder during assembly.
3. Ensure all necessary accessories are prepared before assembly.
4. Assembly is not recommended during heavy wind or rain.
5. Assembly is recommended on level ground.

# Safety Warnings



### **Tool Preparation:**

Prepare commonly used tools in advance, such as an electric drill, level, ladder, and gloves.

### **Foundation Recommendations:**

If the ground is not concrete, it is recommended to reinforce the base or purchase an additional foundation kit beforehand.

### **Regular Fastener Inspection:**

Inspect bolts and connectors every quarter. Tighten any loose hardware as needed.

### **Post-Rain Drainage Notice:**

Clear standing water from the roof to prevent deformation or corrosion caused by water accumulation.

### **Keep Children Away:**

Ensure children stay clear of the installation area and the carport structure during and after assembly to avoid injury.

### **Follow the Installation Instructions Precisely:**

Always follow the step-by-step instructions provided in the manual. Do not skip or rearrange steps, as this may result in instability or incorrect assembly.

### **Experienced Personnel Recommended:**

If you lack DIY experience, the product should be assembled by at least five people with proper installation knowledge, or with professional assistance.

### **Read the Manual Thoroughly Before Starting:**

Be sure to read the entire manual carefully before starting installation. Understanding the structure and process is essential to avoid injury or errors.

### **Use Personal Protective Equipment (PPE):**

Wear anti-slip gloves, safety shoes, and protective eyewear during installation to avoid injury from sharp edges, falling parts, or tools.

### **Risks of Improper Installation:**

Improper assembly may lead to collapse, bolt failure, wood cracking, or injury, compromising both safety and product longevity.

## **Customer Service Guide**



Thank you for choosing our product! We are committed to providing you with excellent service. If you find any missing parts, damaged packaging, or product damage after receiving all packages, please follow the steps below to quickly contact our customer service team. We will do our best to resolve your issue.

### **1. Missing Parts**

#### **Verify Parts:**

1. Refer to the “Parts List” in the manual to verify the name, specifications, and quantity of the missing parts.
2. Take a clear photo of the parts list and mark the missing parts with detailed information, e.g., “Missing 5 pieces of M6×30mm screws.”

#### **Contact Us:**

##### **By Email:**

Send an email to [service@grandtunnel.com](mailto:service@grandtunnel.com), with the subject line “Missing Parts Issue.” Include the following in the email:

- A description of the missing parts and a photo of the parts list.
- Order details (order number, purchase platform, purchase date).

## 2. Product or Packaging Damage

### If it affects normal use:

#### Steps:

1. Take clear photos or videos showing the damaged parts and the extent of the damage (multi-angle shots are recommended).
2. Email the photos/videos along with order details to [service@grandtunnel.com](mailto:service@grandtunnel.com), with the subject line "Product Damage Issue."

#### Resolution:

After verification, we will arrange for a replacement part, product exchange, or refund as quickly as possible.

### If it does not affect normal use:

#### Steps:

1. Contact our customer service team (by email: [service@grandtunnel.com](mailto:service@grandtunnel.com)).
2. Provide a description of the damage and include relevant photos or videos.

#### Resolution:

We will provide repair guidance or an appropriate compensation plan based on the specific situation.

### Contact Us:

Customer Service Email: [service@grandtunnel.com](mailto:service@grandtunnel.com)











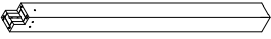
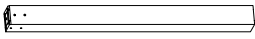
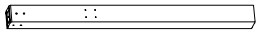

## Helpful Tips

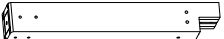
### To process your issue efficiently, please prepare the following information:

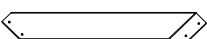

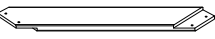

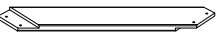
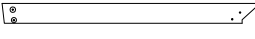

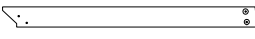
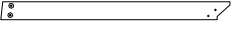
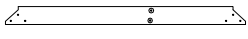
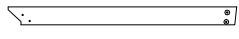
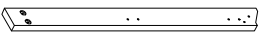
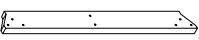
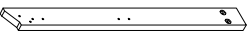
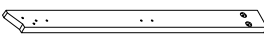
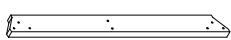
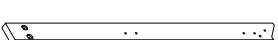

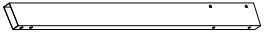
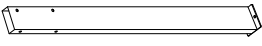
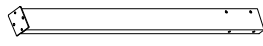
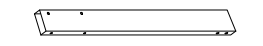
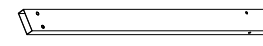
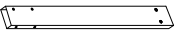

- Order details (order number, purchase platform, purchase date).
- Clear photos or videos.
- We are committed to providing quick and professional solutions, no matter the size of the issue, to ensure your satisfaction.

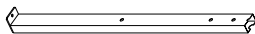
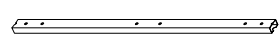
**Thank you for your trust and support!**  
**We hope you enjoy using our product!**



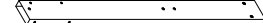
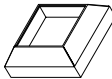
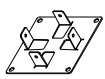
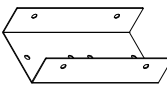
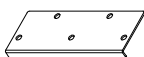
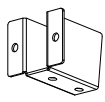

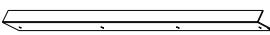
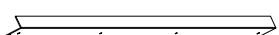
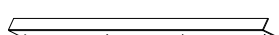





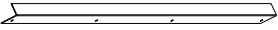

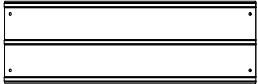
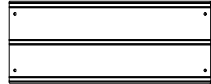
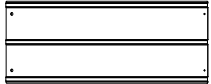

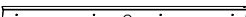
# Parts List

|   |   |   |  |   |
|---|---|---|--|---|
| <p>01</p>     | <p>03</p>    | <p>04</p>    | <p>05</p>    | <p>06</p>    |
| x6  | x2  | x1  | x2   | x1  |
| <p>07</p>     | <p>08</p>    | <p>11</p>    | <p>12</p>    | <p>13</p>    |
| x2  | x1  | x4  | x4   | x2  |
| <p>14</p>  | <p>15</p>  | <p>16</p>  | <p>17</p>  | <p>18</p>  |
| x2  | x2  | x2  | x1   | x1  |
| <p>19</p>   | <p>20</p>  | <p>21</p>  | <p>22</p>  | <p>23</p>  |
| x1  | x1  | x1  | x1   | x1  |
| <p>24</p>   | <p>25</p>  | <p>26</p>  | <p>27</p>  | <p>28</p>  |
| x1  | x1  | x1  | x1   | x1  |



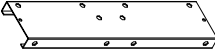

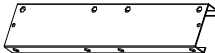

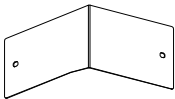
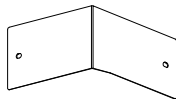





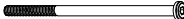



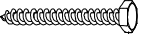

# Parts List

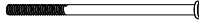
|  |  |  |  |  |
|--|--|--|--|--|
| <b>(B1)</b><br><br>    | <b>(B2)</b><br><br>   | <b>(B3)</b><br><br>   | <b>(B4)</b><br><br>    | <b>(B5)</b><br><br>   |
| <b>x4</b>  | <b>x4</b>  | <b>x4</b>  | <b>x4</b>  | <b>x2</b>  |
| <b>(B6)</b><br><br>    | <b>(B7)</b><br><br>   | <b>(B8)</b><br><br>   | <b>(C1)</b><br><br>    | <b>(C2)</b><br><br>   |
| <b>x2</b>  | <b>x2</b>  | <b>x2</b>  | <b>x8</b>  | <b>x4</b>  |
| <b>(C3)</b><br><br>  | <b>(C4)</b><br><br> | <b>(D1)</b><br><br> | <b>(D2)</b><br><br>  | <b>(D3)</b><br><br> |
| <b>x6</b>  | <b>x3</b>  | <b>x1</b>  | <b>x1</b>  | <b>x1</b>  |
| <b>(M1)</b><br><br> | <b>(M2)</b><br><br> | <b>(N3)</b><br><br> | <b>(N4)</b><br><br> | <b>(N5)</b><br><br> |
| <b>x9</b>  | <b>x9</b>  | <b>x12</b>   | <b>x16</b>   | <b>x4</b>  |
| <b>(N6)</b><br><br> | <b>(P1)</b><br><br> | <b>(P2)</b><br><br> | <b>(P3)</b><br><br>  | <b>(P4)</b><br><br> |
| <b>x4</b>  | <b>x1</b>  | <b>x1</b>  | <b>x1</b>  | <b>x1</b>  |

## Parts List

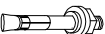
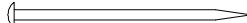
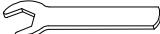
|  |  |  |   |  |
|--|--|--|---|--|
| <p>Ⓟ</p>     | <p>Ⓠ</p>    | <p>Ⓠ</p>    | <p>Ⓠ</p>    | <p>Ⓠ</p>    |
| x2   | x16  | x16  | x16   | x16  |
| <p>Ⓡ</p>     | <p>Ⓡ</p>    | <p>Ⓡ</p>    | <p>Ⓡ</p>    | <p>Ⓡ</p>    |
| x1   | x1   | x1   | x1  | x1   |
| <p>Ⓡ</p>   | <p>Ⓢ</p>  | <p>Ⓨ</p>  | <p>Ⓨ</p>  | <p>Ⓨ</p>  |
| x1   | x45  | x2   | x14   | x12  |
| <p>Ⓨ</p>  | <p>Ⓨ</p>  | <p>Ⓨ</p>  | <p>Ⓨ</p>  |  |
| x1   | x1   | x1   | x1  |  |
|  |  |  |   |  |
|  |  |  |   |  |

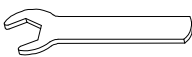
# Hardware List

|  |  |   |  |  |
|--|--|---|--|--|
| <p>AA</p>  <p>M4x16</p>   | <p>BB</p>  <p>M6x20</p>   | <p>CC</p>  <p>M6x30</p>    | <p>EE</p>  <p>M6x110</p> | <p>FF</p>  <p>M6x20</p> |
| x120+10  | x104+5   | x56+3   | x48+2  | x96+4  |
| <p>GG</p>  <p>M6x15</p>   | <p>HH</p>  <p>M6x35</p>   | <p>H4</p>  <p>M5x25</p>    | <p>H5</p>  <p>M6</p>    | <p>H6</p>  <p>M8x70</p> |
| x204+10  | x42+3  | x50+5   | x64+5  | x1   |
| <p>H8</p>  <p>M5x35</p> | <p>H9</p>  <p>M8</p>    | <p>JJ</p>  <p>M8x170</p> | <p>KK</p>             | <p>LL</p>  <p>M8</p>  |
| x64+6  | x87+6  | x29+2   | x96+5  | x35+2  |
| <p>NN</p>  <p>M8x200</p> | <p>UU</p>  <p>M6x80</p> | <p>PP</p>  <p>D8x180</p> | <p>Z1</p>  <p>M6</p>   | <p>Z2</p>  <p>M6</p>  |
| x6   | x18  | x18   | x2   | x2   |
| <p>Z3</p>  <p>M8</p>    | <p>Z4</p>  <p>M8</p>    |   |  |  |
| x2   | x2   |   |  |  |

1

As shown in the diagram, place the parts.

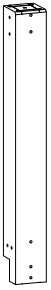

05 x2



01 x2

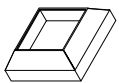

M1 x2

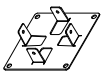

M2 x2

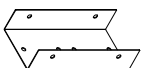

N3 x4

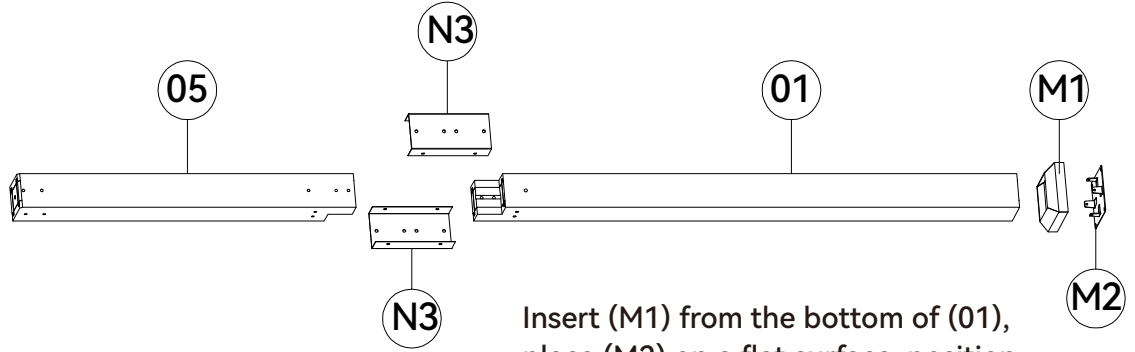

Insert (M1) from the bottom of (01), place (M2) on a flat surface, position the bottom of (01) onto (M2), and secure with self-tapping screws (H4) as shown.

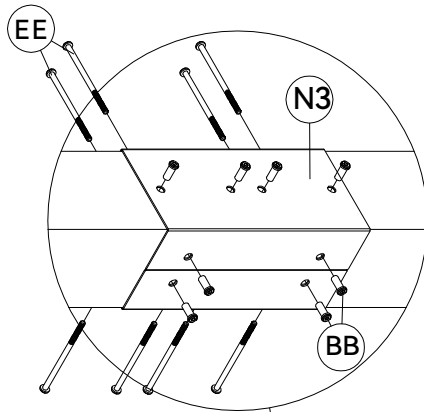

Connect (05) and (01) using two (N3) parts and through bolts (EE)+(BB). Install loosely at first, then tighten.

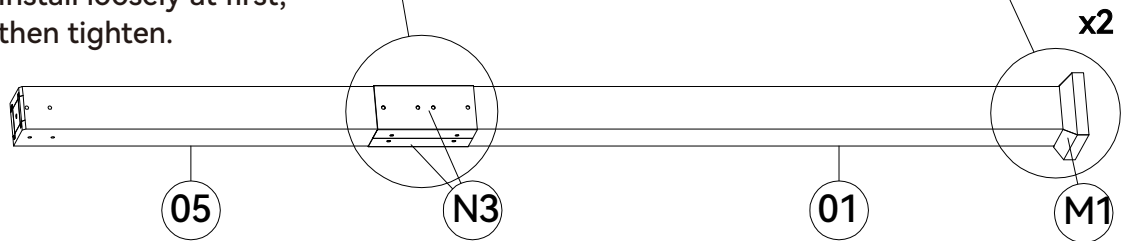
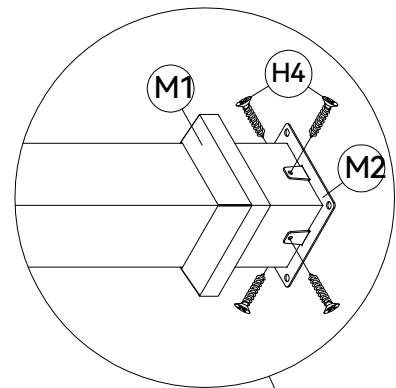

x2

H4 x8



M5x25

BB x16



M6x20

EE x16



M6x110

2

As shown in the diagram, place the parts.

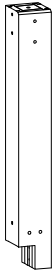

07 x2

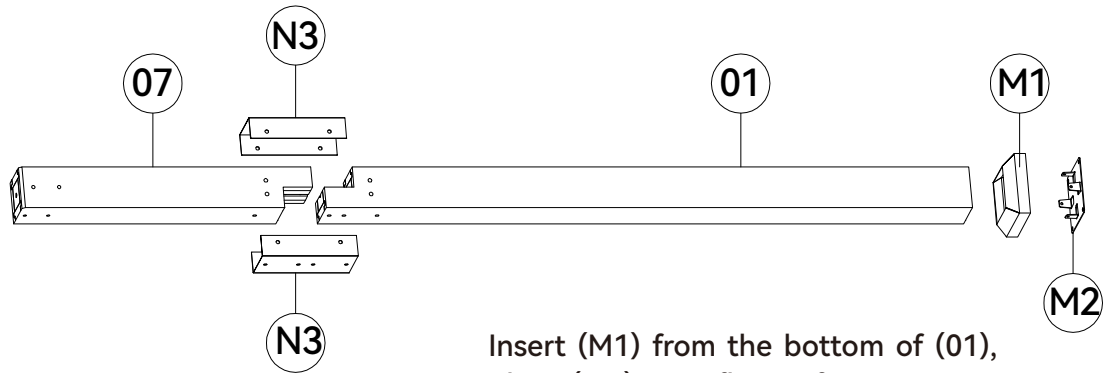

Insert (M1) from the bottom of (01), place (M2) on a flat surface, position the bottom of (01) onto (M2), and secure with self-tapping screws (H4) as shown.

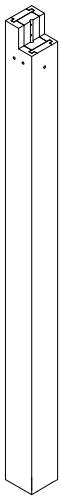

01 x2

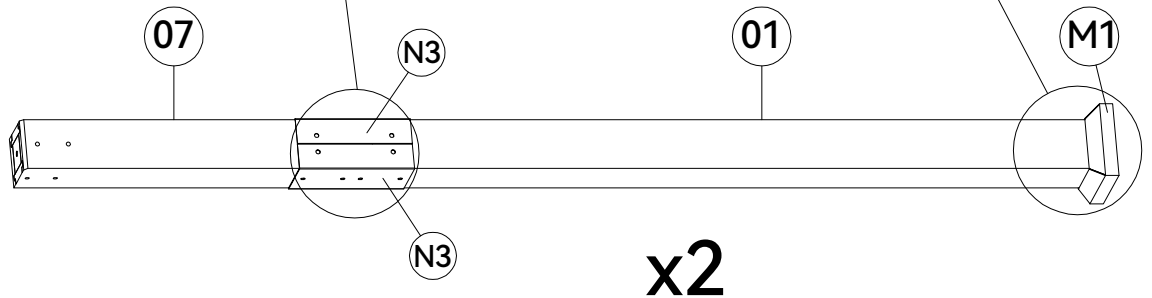
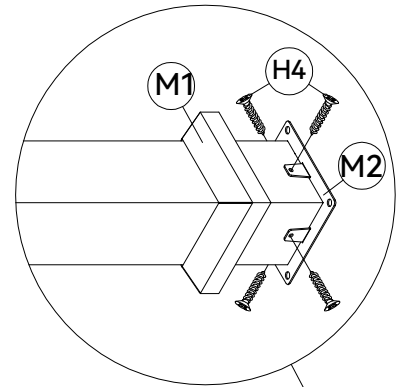
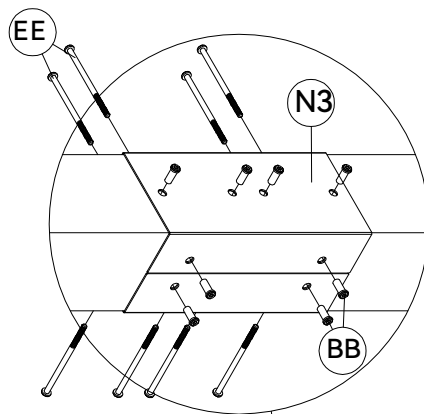

x2

Connect (07) and (01) using two (N3) parts and through bolts (EE)+(BB). Install loosely at first, then tighten.

**Note: Loosely install the screws first, and then tighten them all after assembly is complete.**

H4 x8



M5x25

BB x16



M6x20

EE x16



M6x110

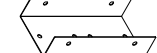

N3 x4

3

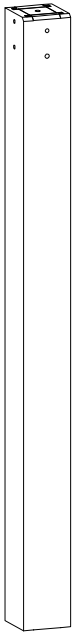

03 x2

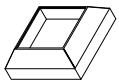

M1 x2

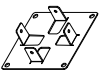

M2 x2

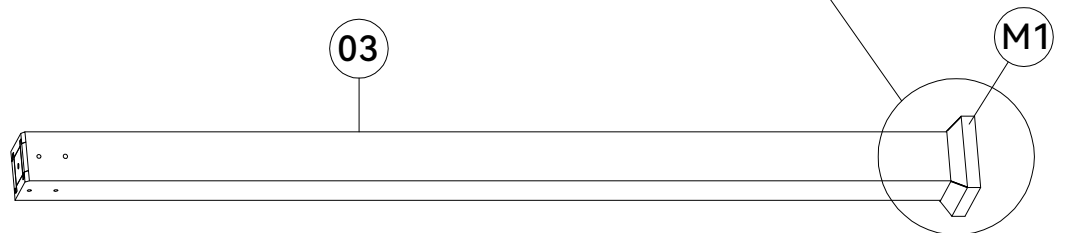
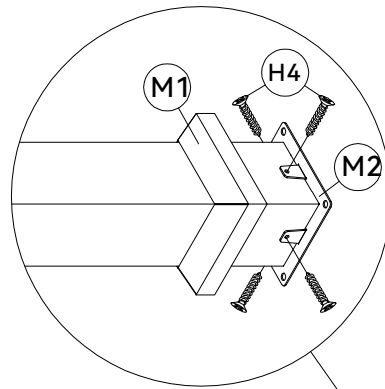
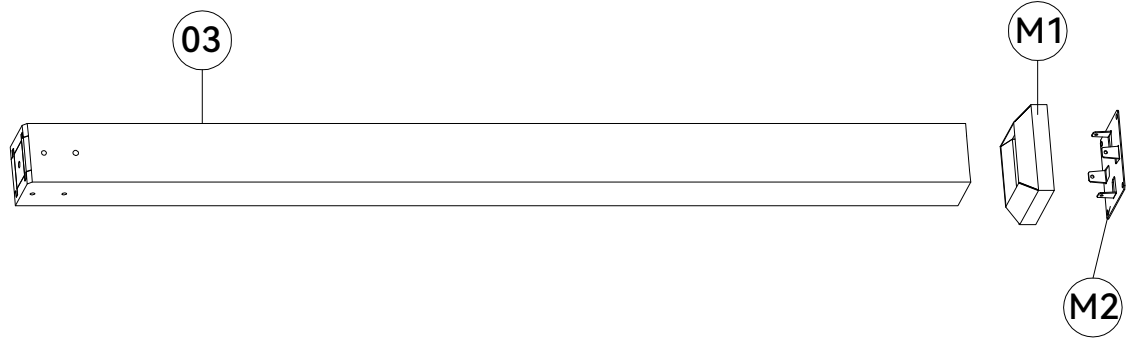

x2

Insert (M1) into the bottom of (03), place (M2) on a flat surface, position the bottom of (03) onto (M2), and secure with self-tapping screws (H4) as shown.

H4 x8



M5x25

4

As shown in the diagram, place the parts.

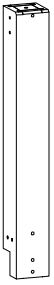

06 x1

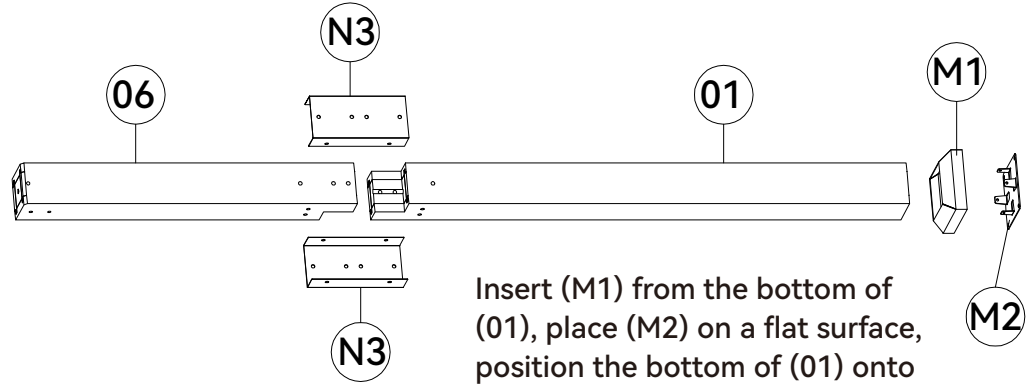

Insert (M1) from the bottom of (01), place (M2) on a flat surface, position the bottom of (01) onto (M2), and secure with self-tapping screws (H4) as shown.

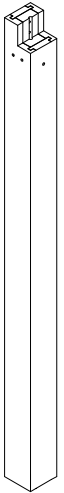

01 x1

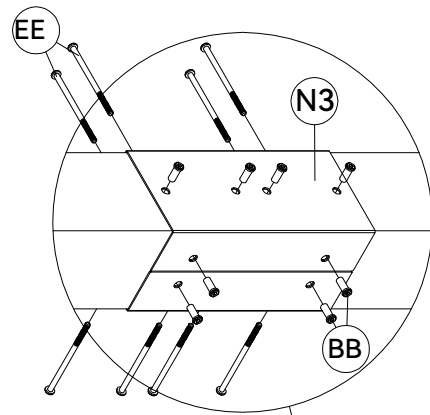

Connect (06) and (01) using two (N3) parts and through bolts (EE)+(BB). Install loosely at first, then tighten.

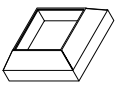
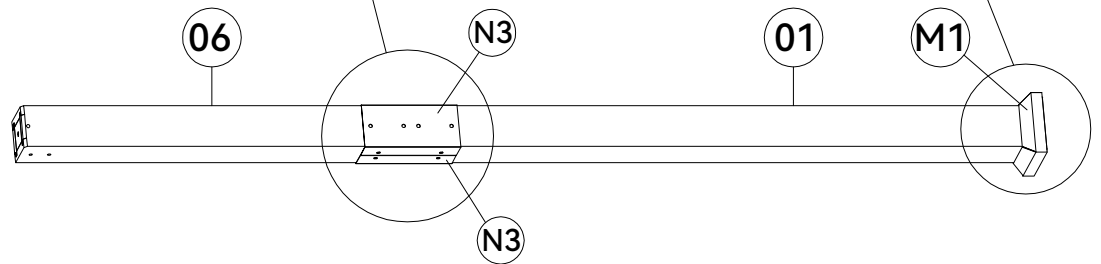
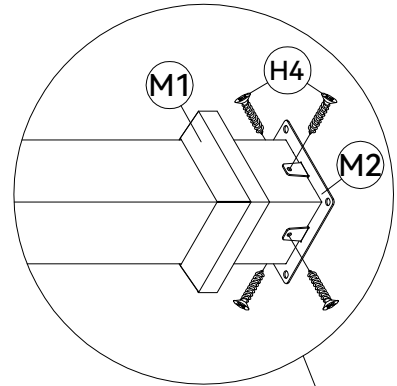

M1 x1



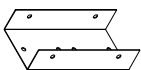

M2 x1



N3 x2

**Note: Loosely install the screws first, and then tighten them all after assembly is complete.**

H4 x4  
  
 M5x25

BB x8  
  
 M6x20

EE x8  
  
 M6x110

5

As shown in the diagram, place the parts.



08 x1

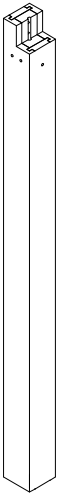

01 x1

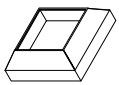

M1 x1

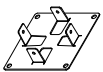

M2 x1

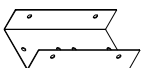

N3 x2

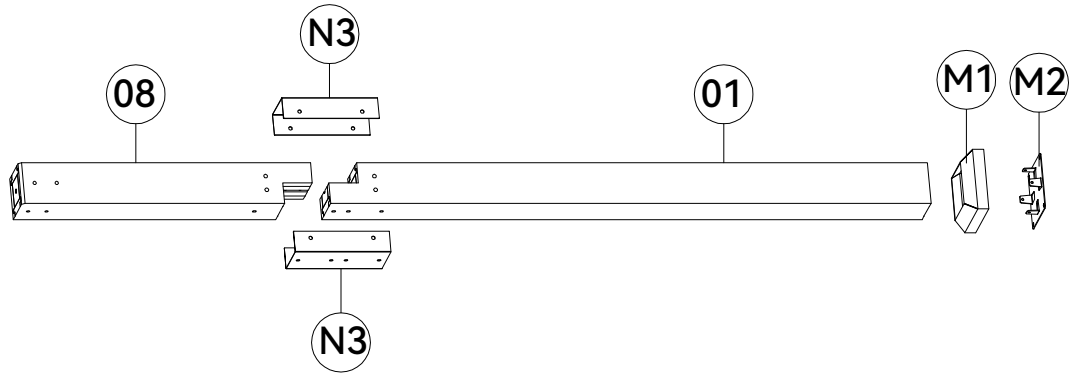

Insert (M1) from the bottom of (01), place (M2) on a flat surface, position the bottom of (01) onto (M2), and secure with self-tapping screws (H4) as shown.

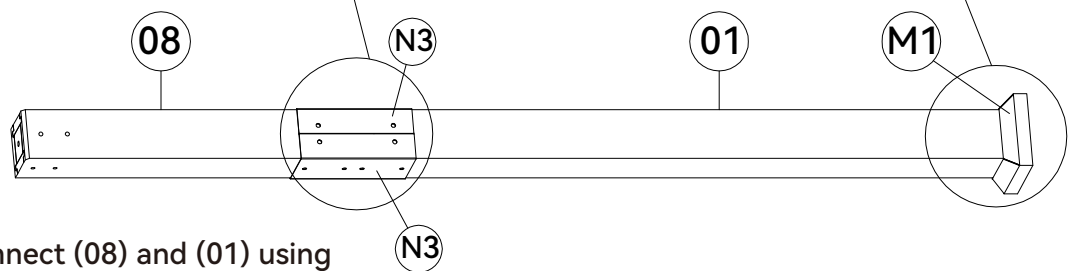
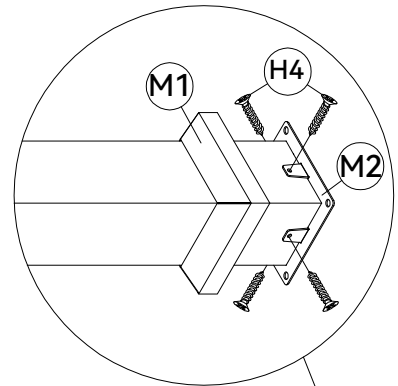
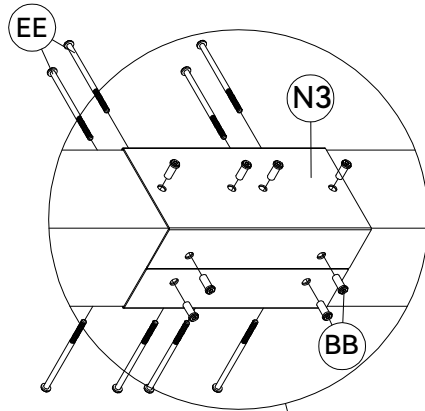

Connect (08) and (01) using two (N3) parts and through bolts (EE)+(BB). Install loosely at first, then tighten.

**Note: Loosely install the screws first, and then tighten them all after assembly is complete.**

H4 x4



M5x25

BB x8



M6x20

EE x8



M6x110

6



04 x1

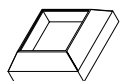

M1 x1

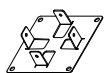

M2 x1

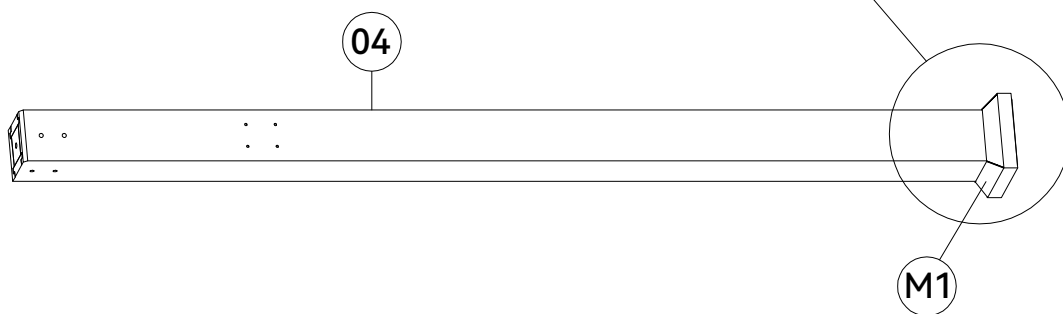
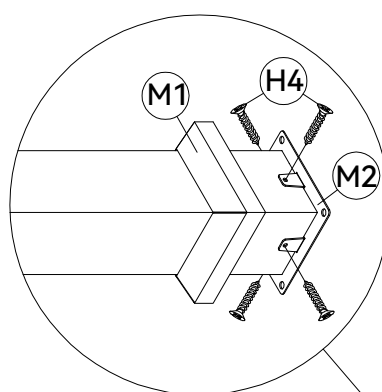
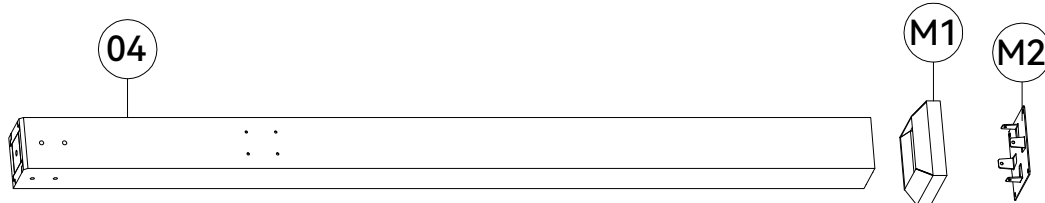

Insert (M1) into the bottom of (04), place (M2) on a flat surface, position the bottom of (04) onto (M2), and secure with self-tapping screws (H4) as shown.

H4 x4



M5x25

7



19 x1

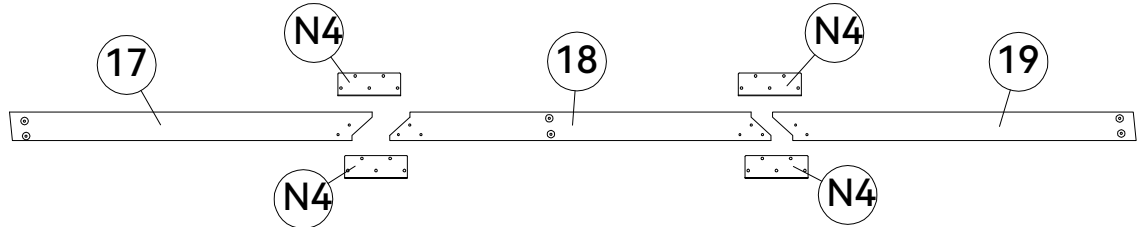
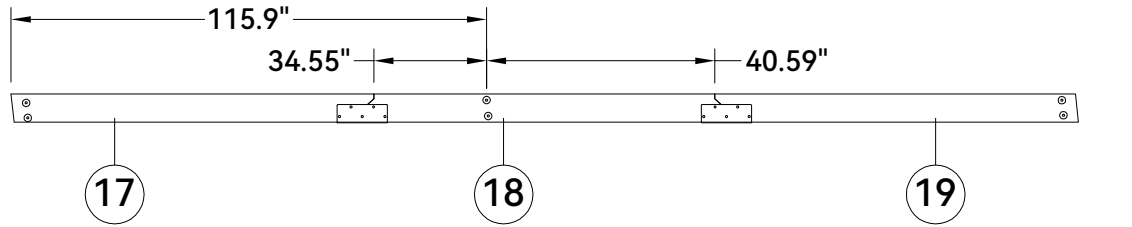

As shown in the diagram, place the parts.



18 x1

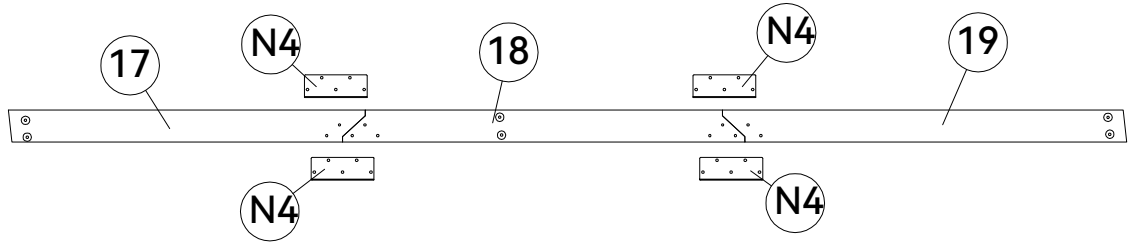

Connect (17), (18), and (19) as shown, ensuring correct hole spacing.



17 x1

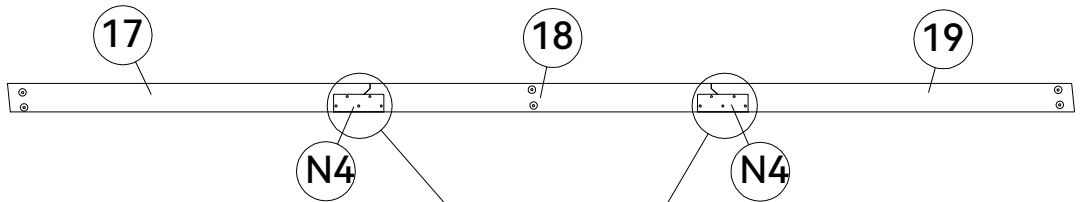

Install (N4) and secure with through bolts (BB)+(CC).

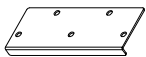
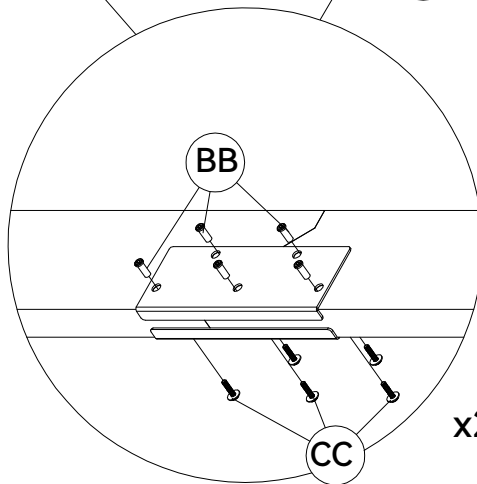

N4 x4

BB x10



M6x20

CC x10

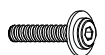

M6x30

8



22 x1



21 x1

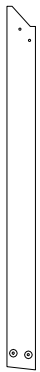

20 x1

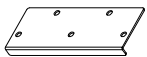

N4 x4

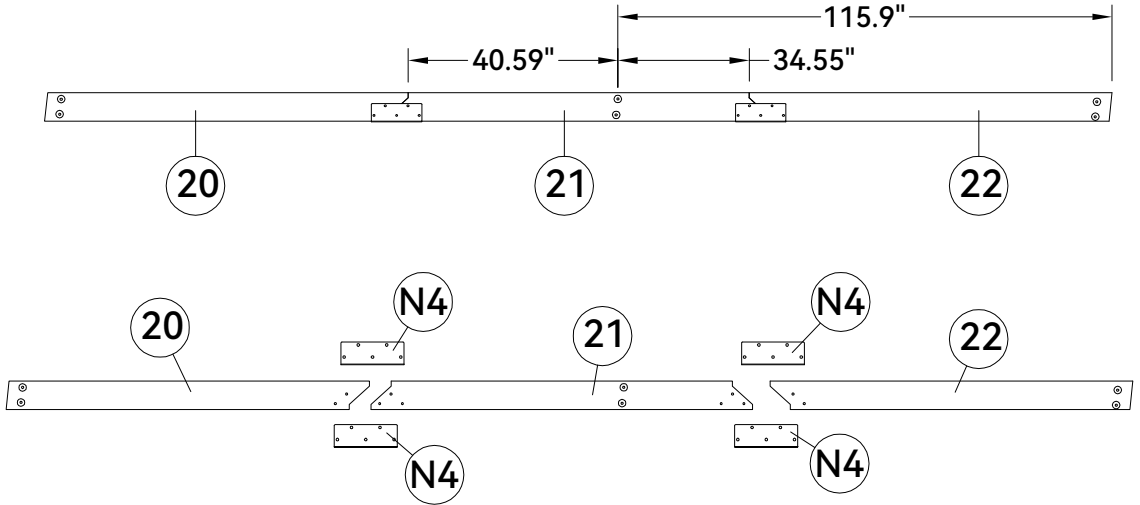

As shown in the diagram, place the parts.

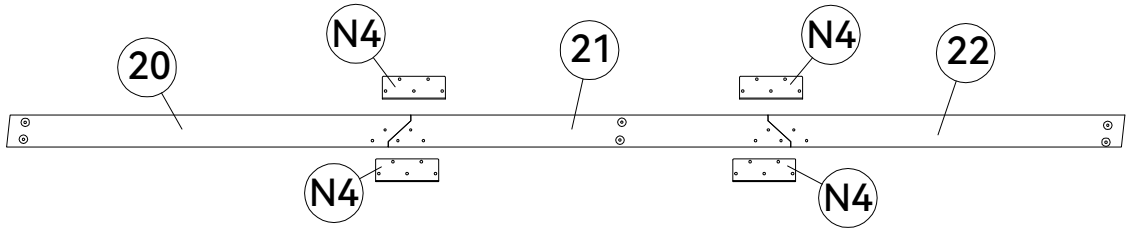

Connect (20), (21), and (22) as shown, ensuring correct hole spacing.

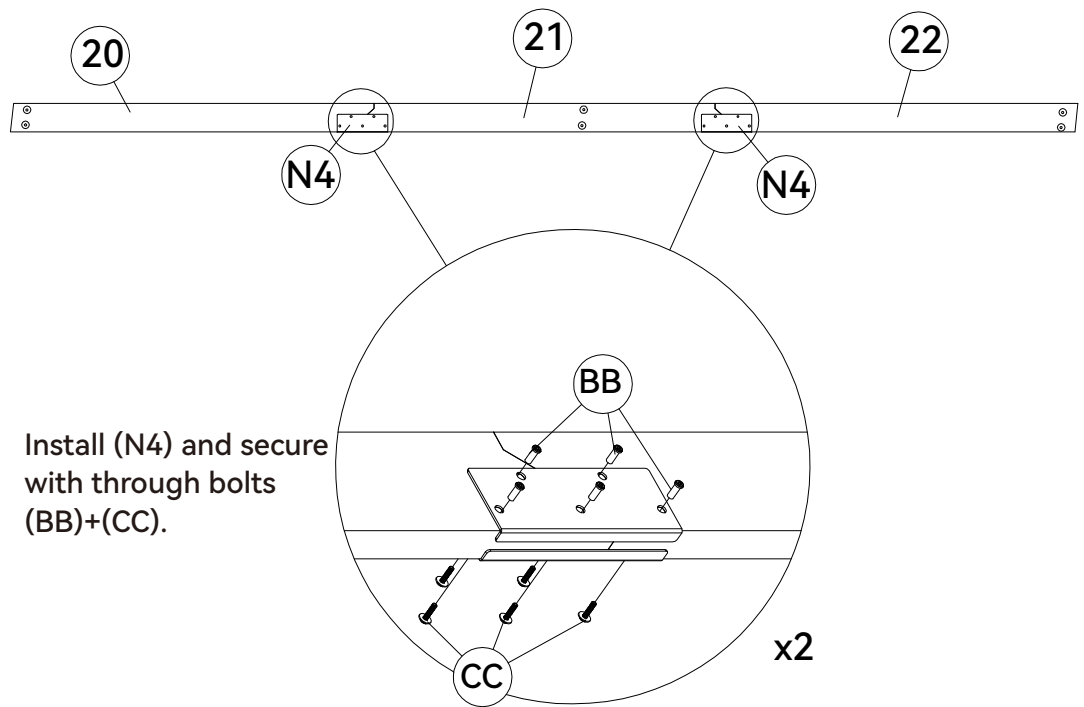

Install (N4) and secure with through bolts (BB)+(CC).

x2

BB x10



M6x20

CC x10

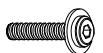

M6x30

9



25 x1

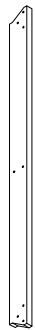

24 x1

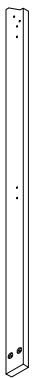

23 x1

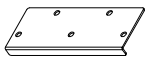

N4 x4

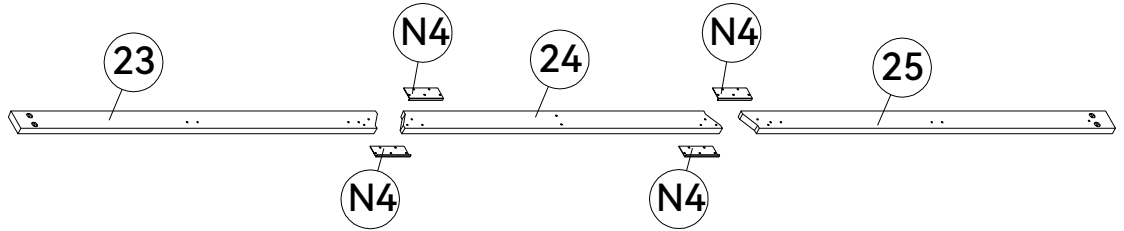
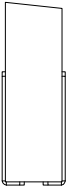
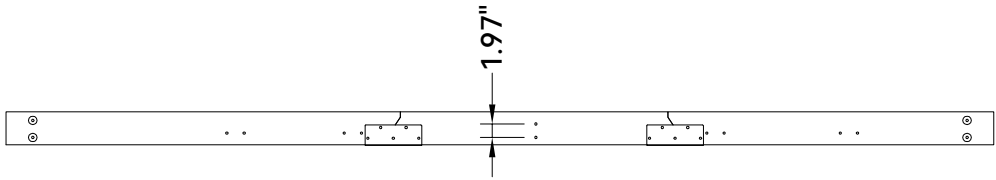

As shown in the diagram, place the parts.

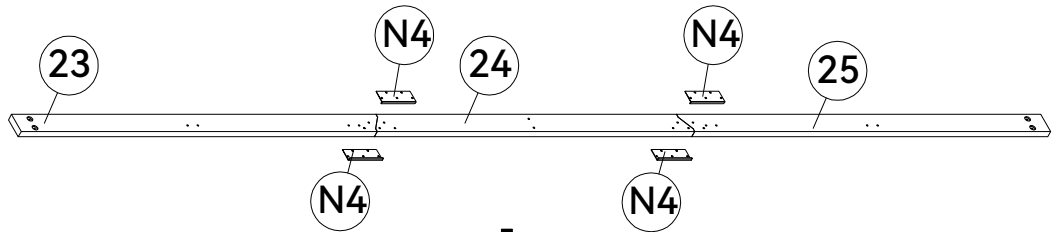

Connect (23), (24), and (25) as shown, ensuring correct hole spacing.

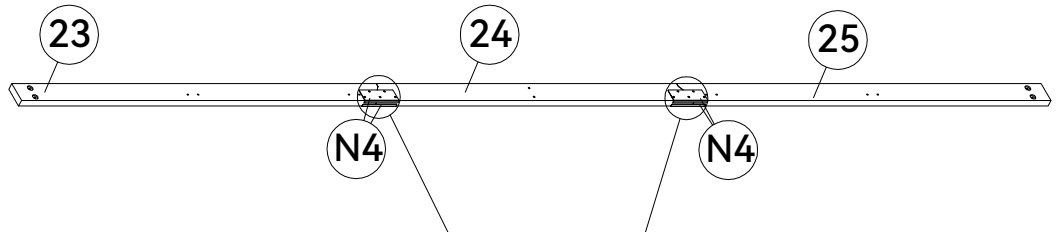

Install (N4) and secure with through bolts (BB)+(CC).

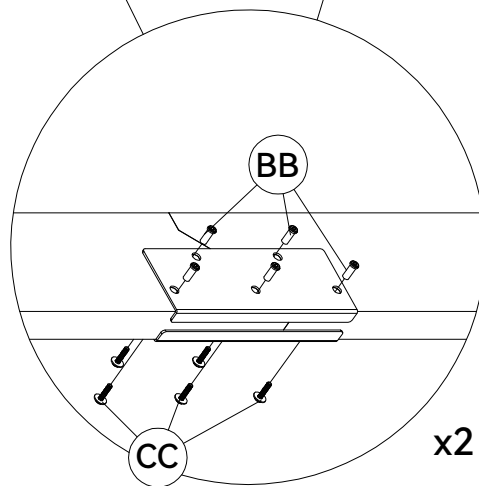

BB x10



M6x20

CC x10

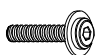

M6x30

10

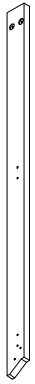

26 x1

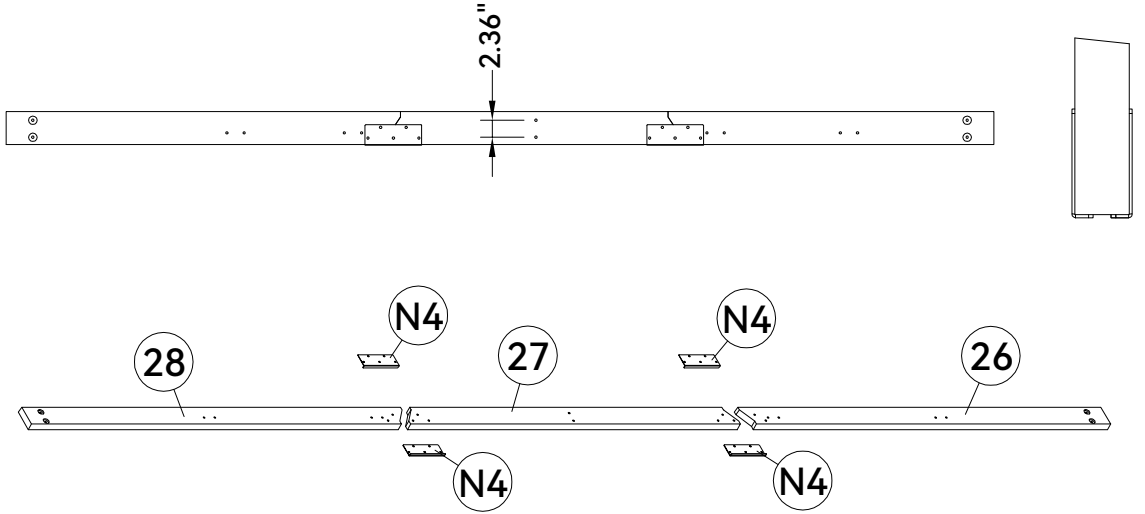

As shown in the diagram, place the parts.



27 x1

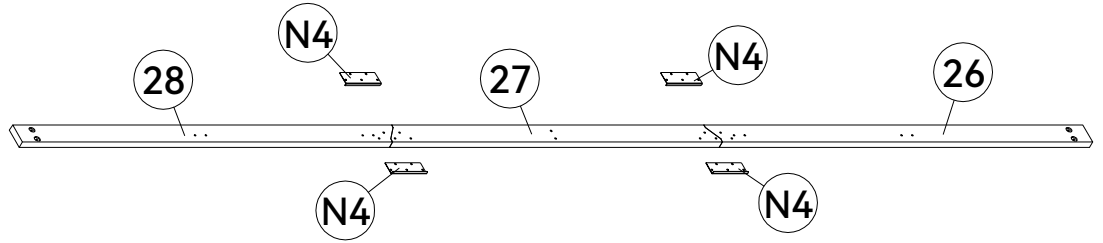

Connect (28), (27), and (26) as shown, ensuring correct hole spacing.



28 x1

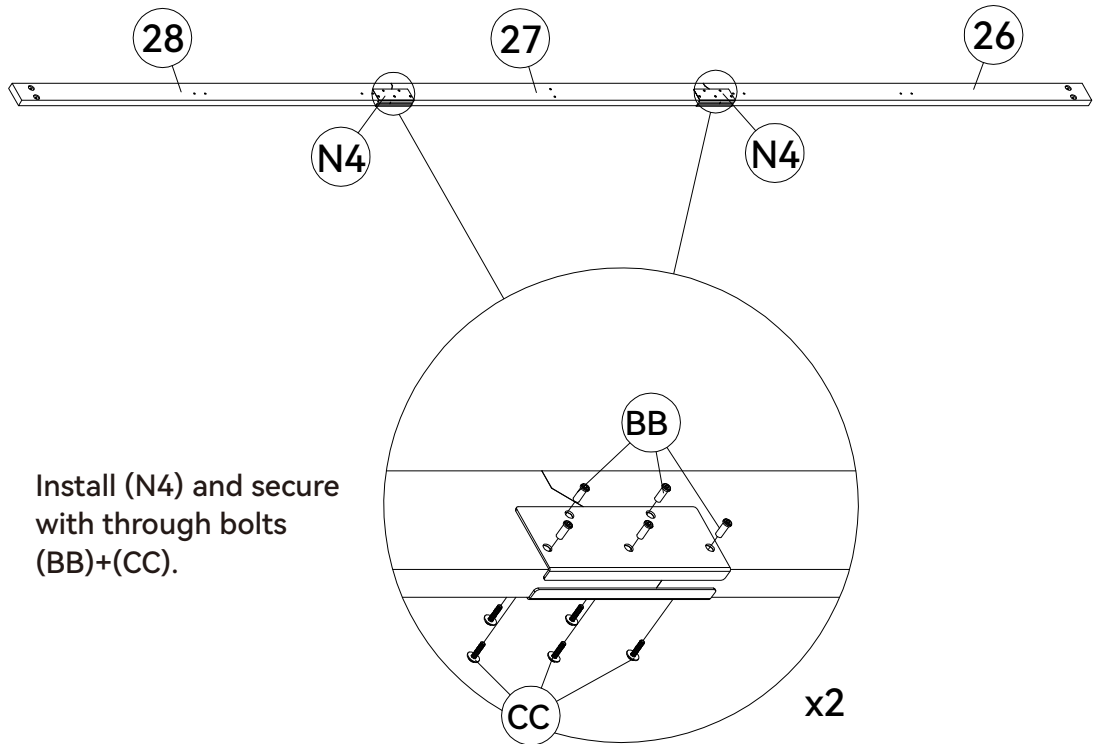

Install (N4) and secure with through bolts (BB)+(CC).

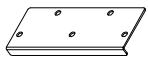

N4 x4

BB x10



M6x20

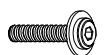

CC x10

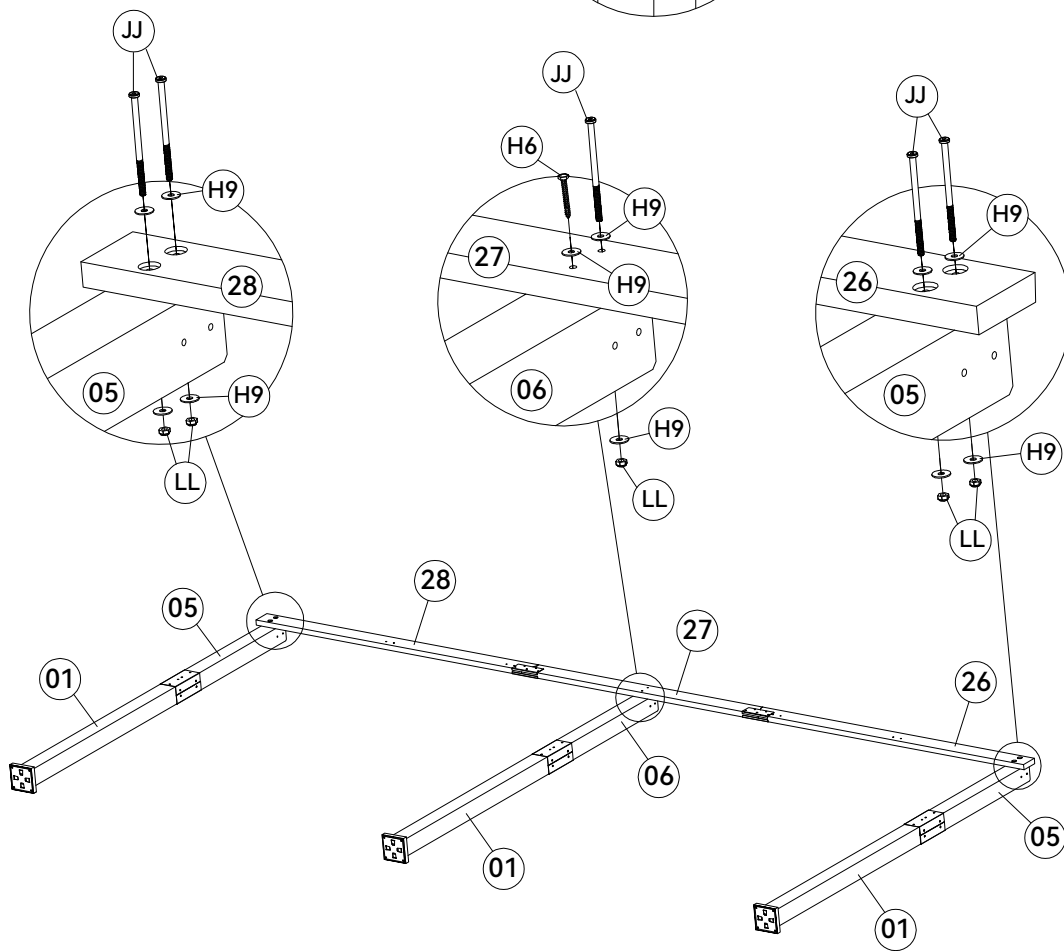
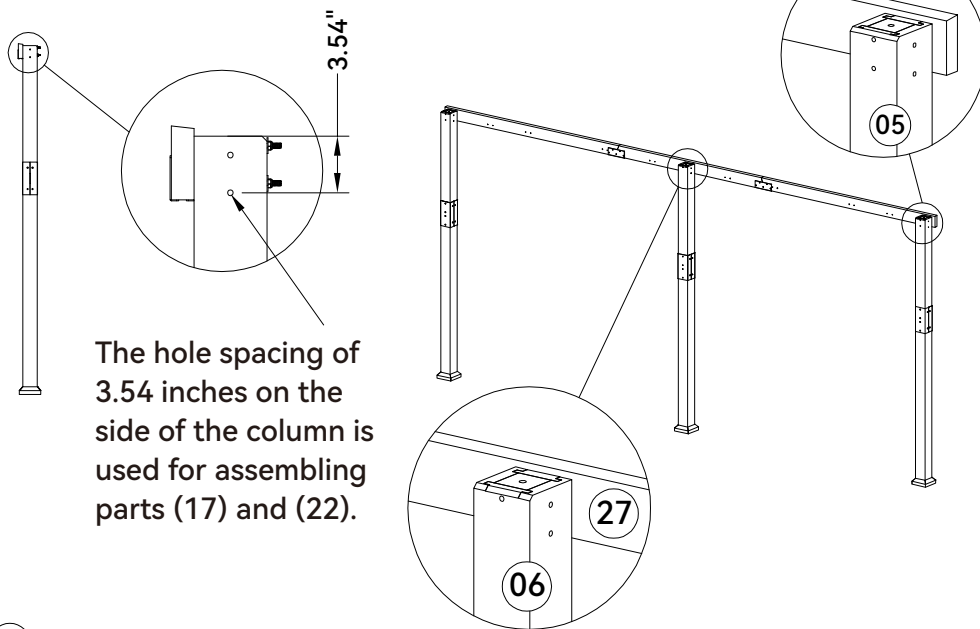

M6x30



As shown, install the beams onto the posts. Connect beam (28) to post (05), one side uses screw (JJ)+washer (H9), the other uses nut (LL)+washer (H9). Connect beam (27) to post (06), similarly secure with screws/nuts and washers. Repeat for beam (26) to post (05). Also install self-tapping screws (H6)+washer (H9).

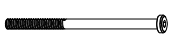

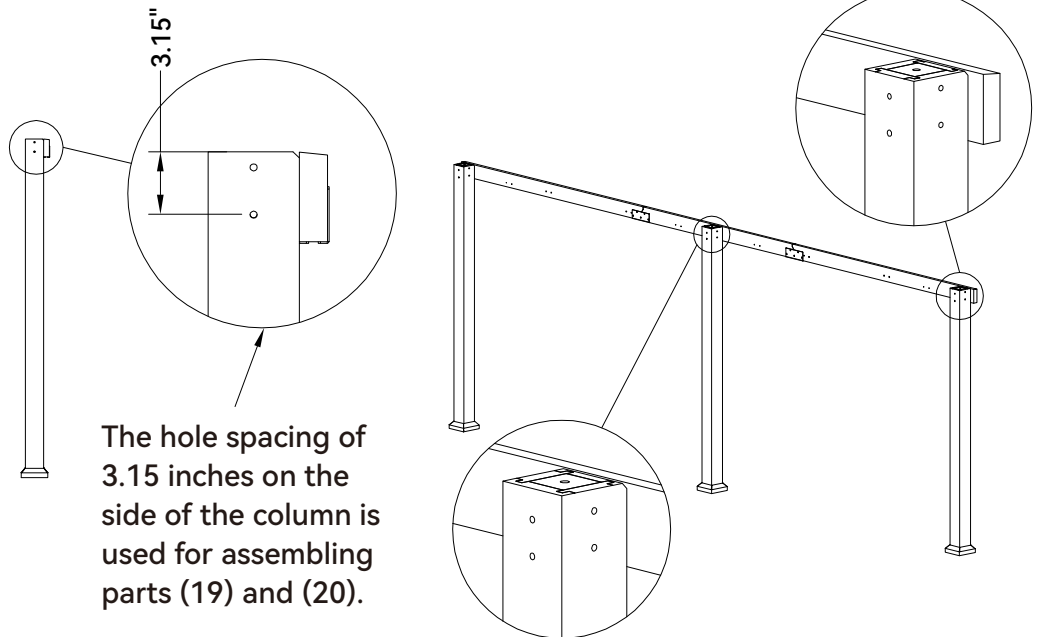
|   |  |   |  |
|---|--|---|--|
| <p>(H6) x1</p>  <p>M8x70</p> | <p>(LL) x5</p>  <p>M8</p> | <p>(H9) x11</p>  <p>M8</p> | <p>(JJ) x5</p>  <p>M8x170</p> |
|---|--|---|--|

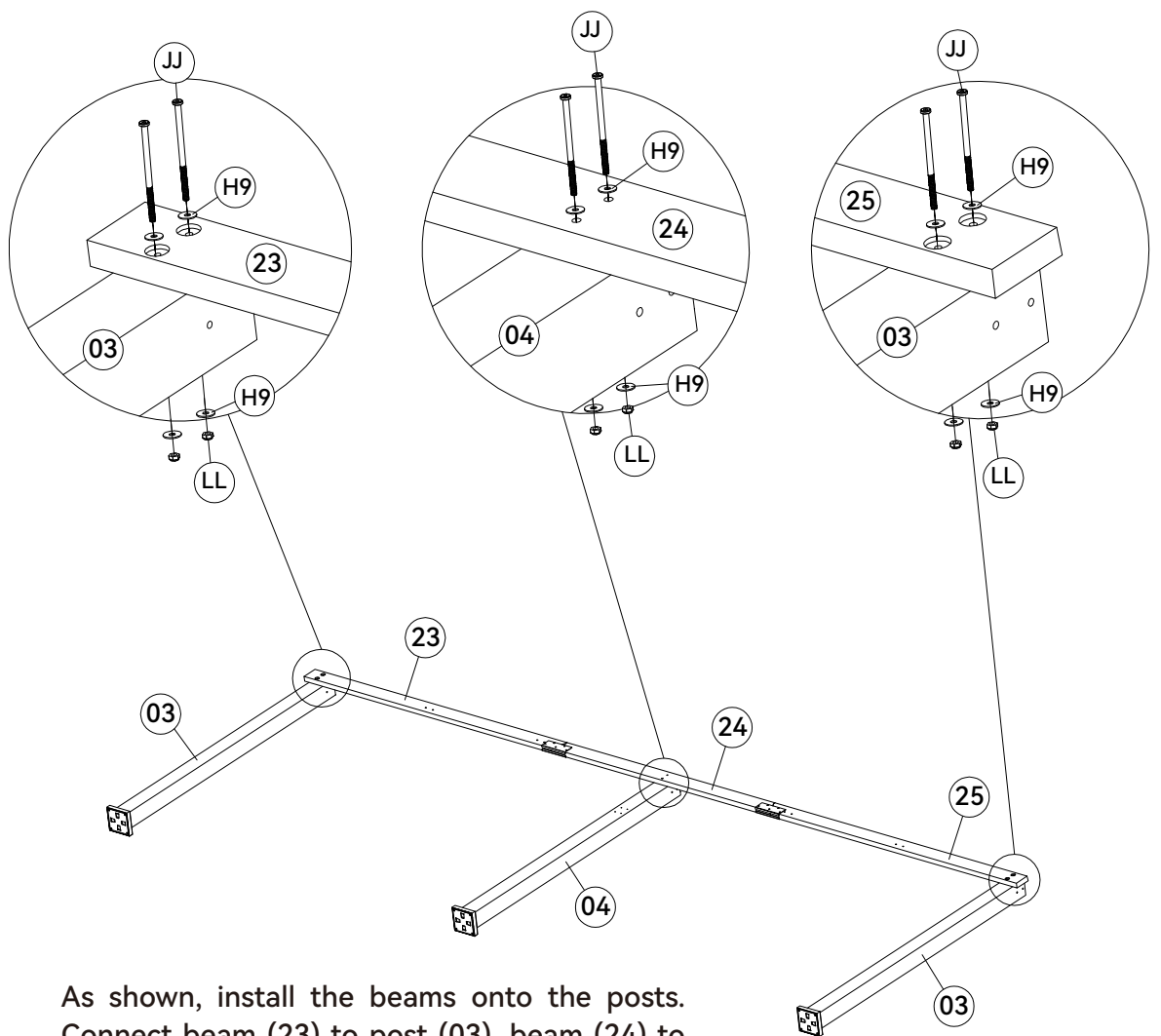

The hole spacing of 3.15 inches on the side of the column is used for assembling parts (19) and (20).



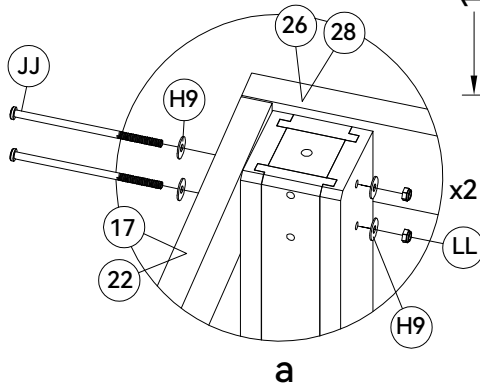
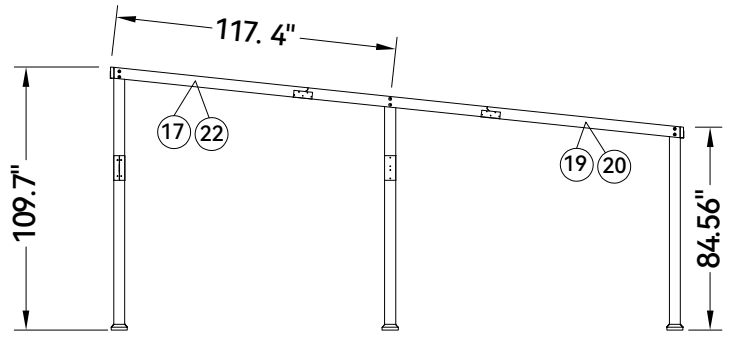

As shown, install the beams onto the posts. Connect beam (23) to post (03), beam (24) to post (04), and beam (25) to post (03). One side uses screw (JJ)+washer (H9), the other uses nut (LL)+washer (H9).

|  |   |  |
|--|---|--|
| <p>(LL) x6</p>  <p>M8</p> | <p>(H9) x12</p>  <p>M8</p> | <p>(JJ) x6</p>  <p>M8x170</p> |
|--|---|--|

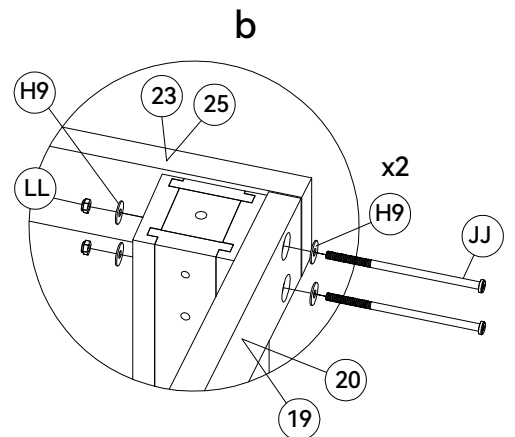
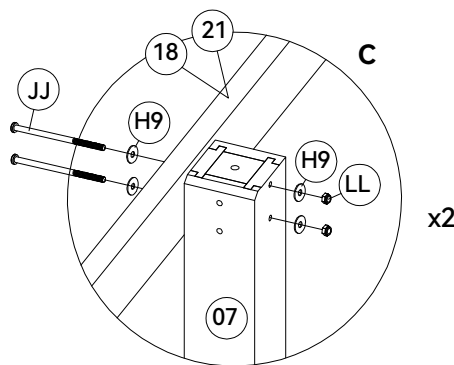
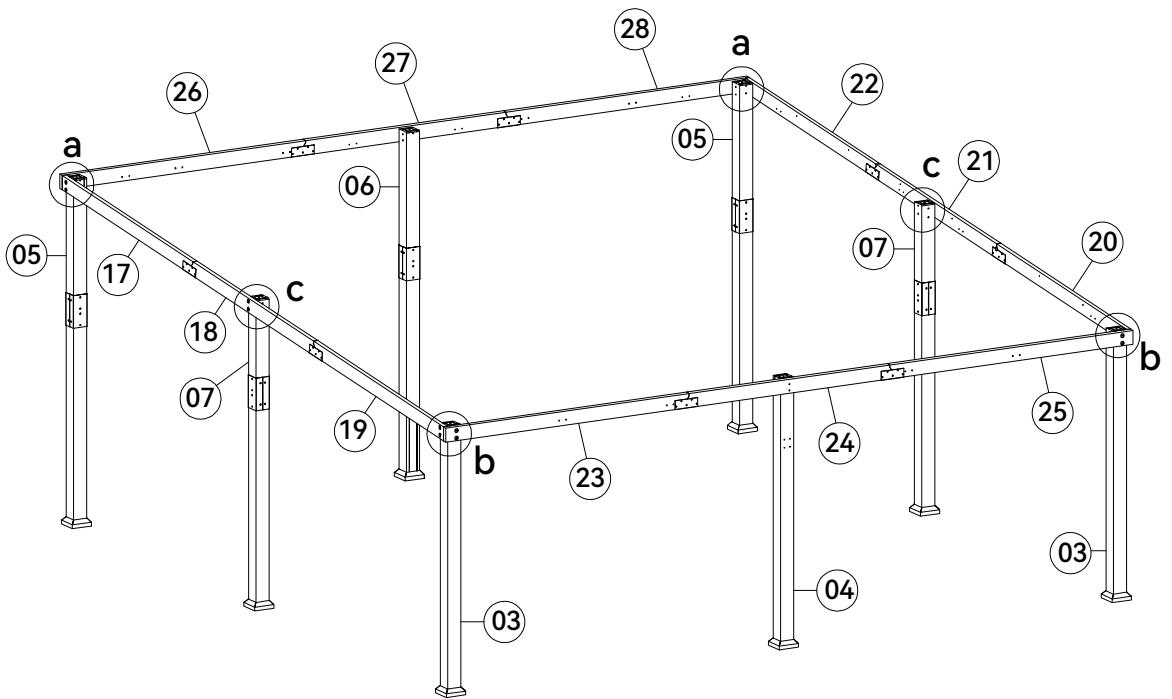

Install beam (17), then (19), and finally the center beam (18), securing one side with screw (JJ)+washer (H9) and the other with nut (LL)+washer (H9). Then install beam (22), then (20), and finally center beam (21) using the same method.

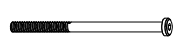

|   |   |   |
|---|---|---|
| <p>LL x12</p>  <p>M8</p> | <p>H9 x24</p>  <p>M8</p> | <p>JJ x12</p>  <p>M8x170</p> |
|---|---|---|

14



13 x2



15 x2

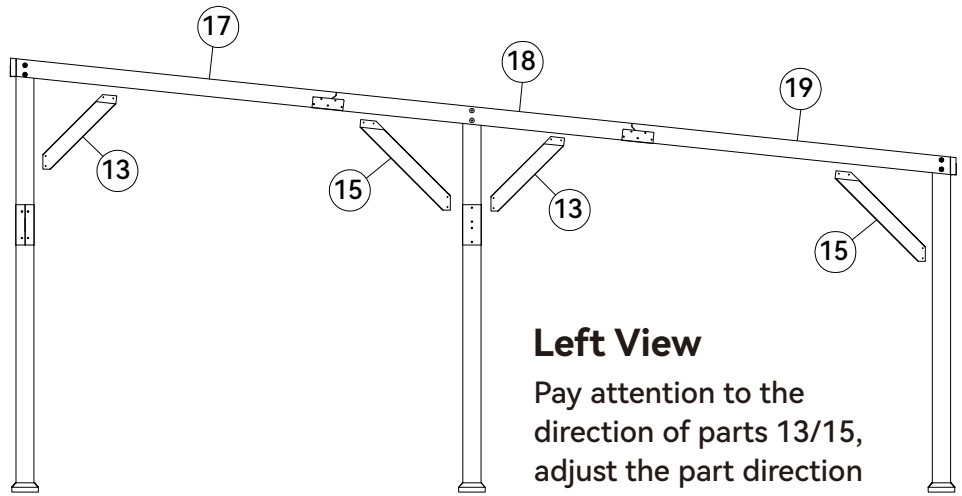

**Left View**

Pay attention to the direction of parts 13/15, adjust the part direction when there are gaps.

Install diagonal braces (13) and (15) as shown. Pay attention to orientation, if there is a gap, reverse the part. After installation, the bottom of the two center braces should be flush. Secure both ends with self-tapping screws (H8)+washer (H5).

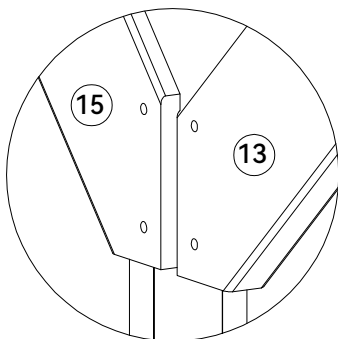
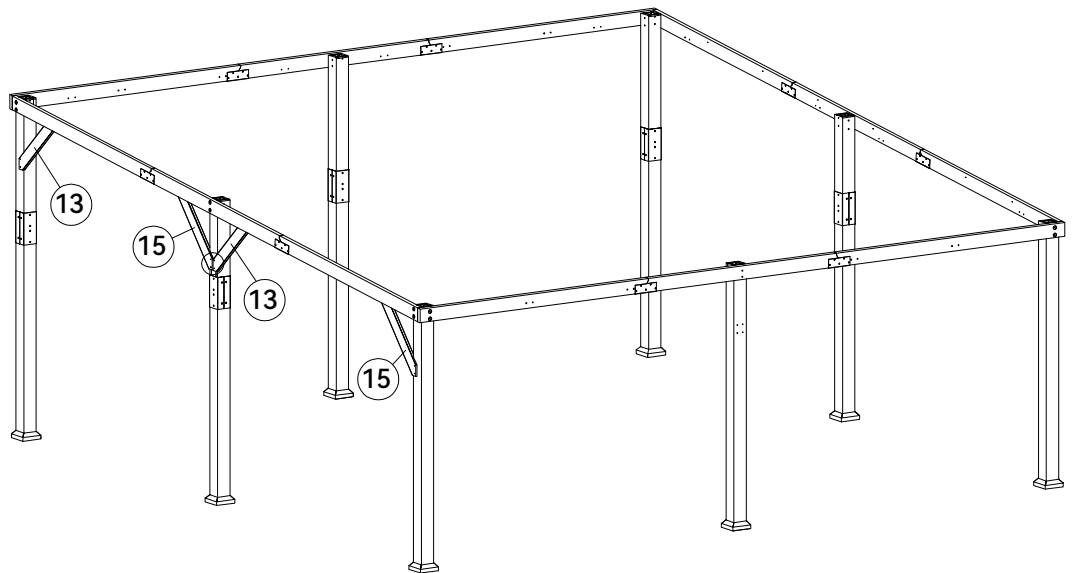

Bottom Alignment

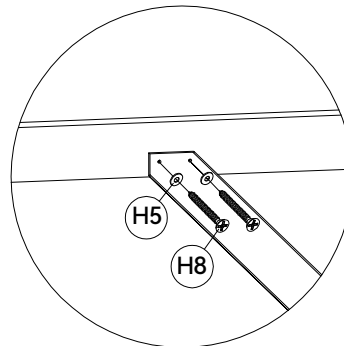

Note that the component clips are aligned with the crossbeam.

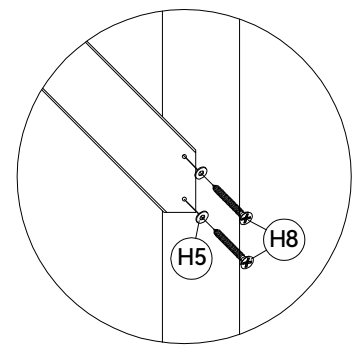

H8 x16



M5x35

H5 x16



M6

15

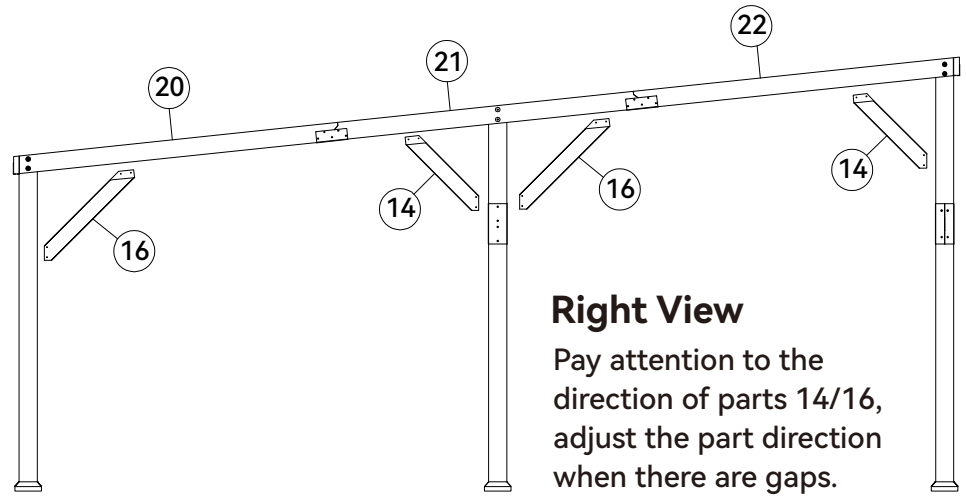
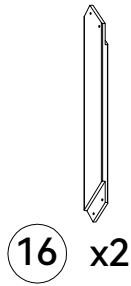
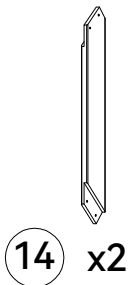

Install diagonal braces (14) and (16) as shown. Pay attention to orientation, if there is a gap, reverse the part. After installation, the bottom of the two center braces should be flush. Secure both ends with self-tapping screws (H8)+washer (H5).

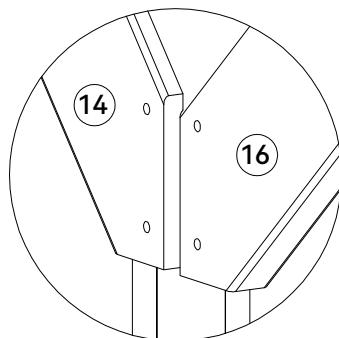
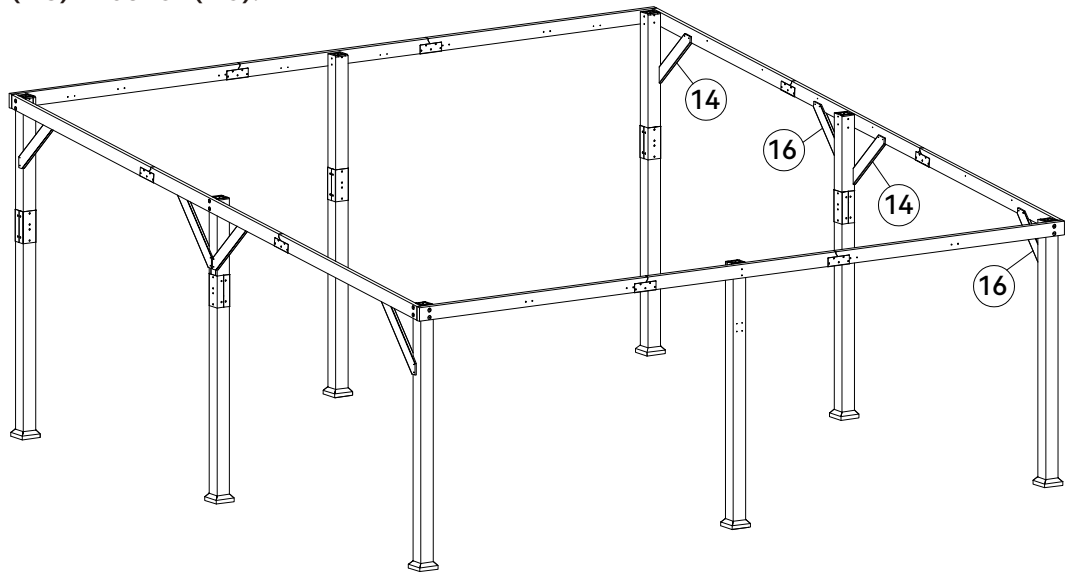

Bottom Alignment

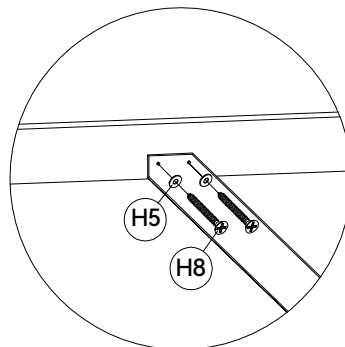

Note that the component clips are aligned with the crossbeam.

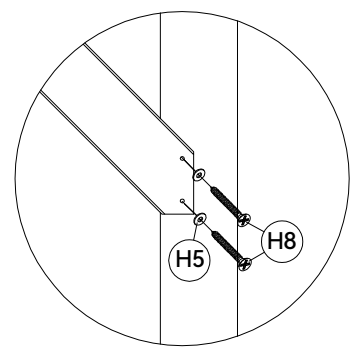

H8 x16



M5x35

H5 x16



M6

# 16

Install diagonal braces (11) and (12) as shown. Pay attention to orientation, if there is a gap, reverse the part. After installation, the bottom of the two center braces should be flush. Secure both ends with self-tapping screws (H8)+washer (H5).

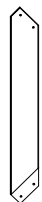

11 x4



12 x4

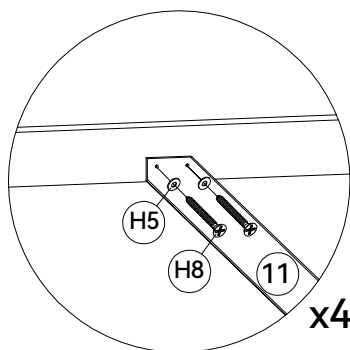

x4

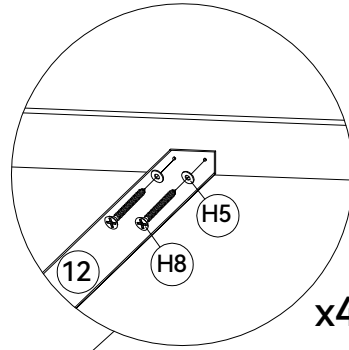

x4

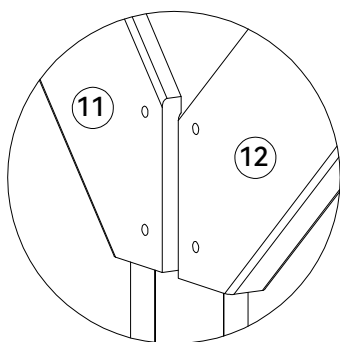
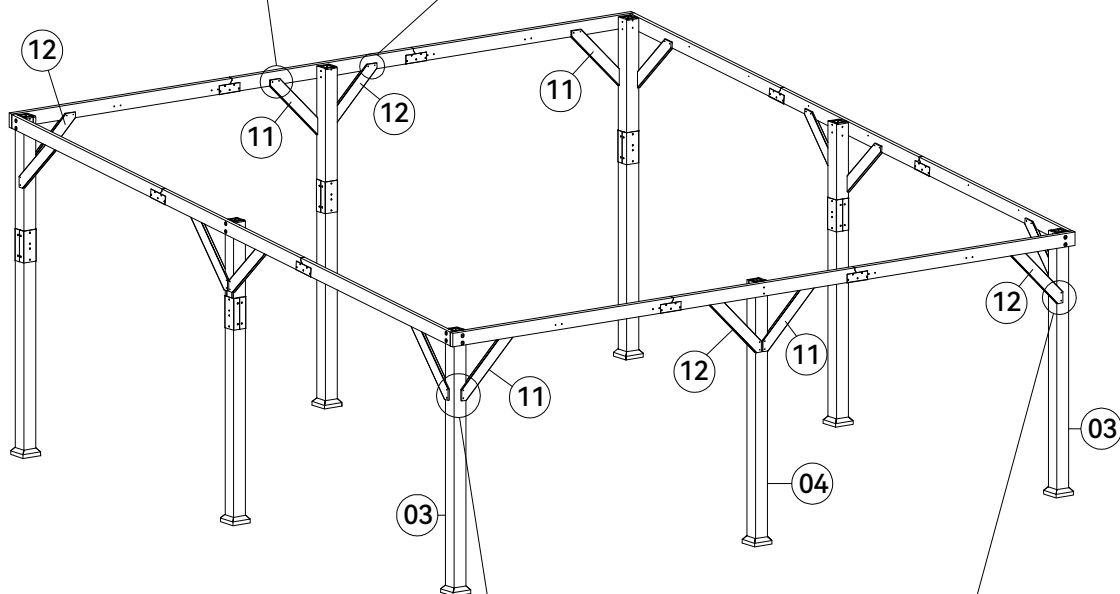

Bottom Alignment

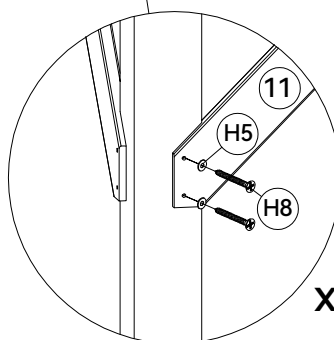

x4

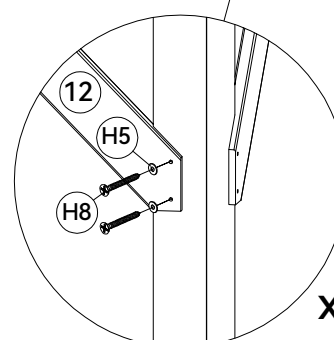

x4

H8 x32



M5x35

H5 x32



M6

17



D1 x1



D2 x1



D3 x1



Y1 x2

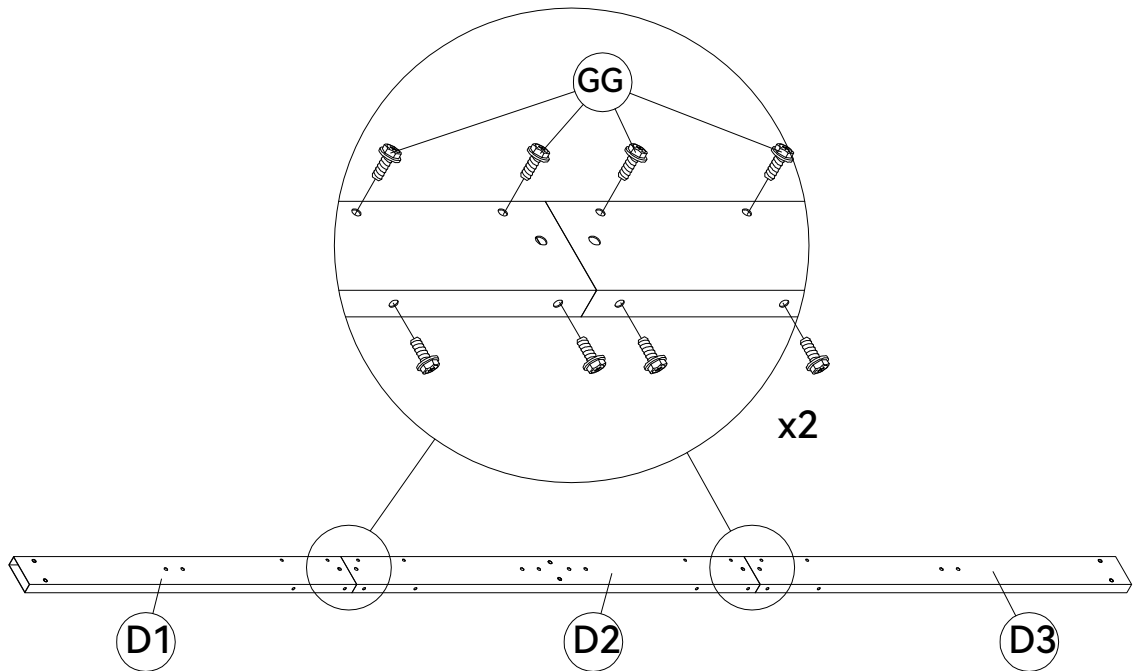
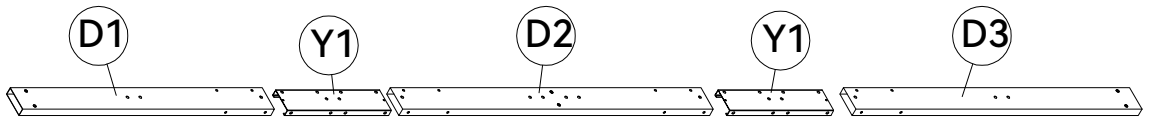

As shown, place parts (D1), (Y1), (D2), (Y1), and (D3). Loosely install screws (GG) first, then fully tighten after assembly.

**Note: Loosely install the screws first, and then tighten them all after assembly is complete.**

GG x16



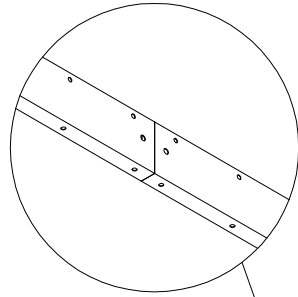

M6x15

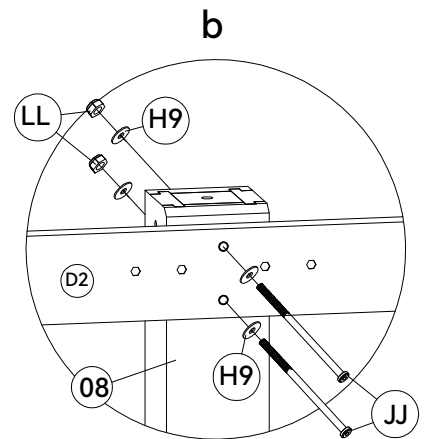
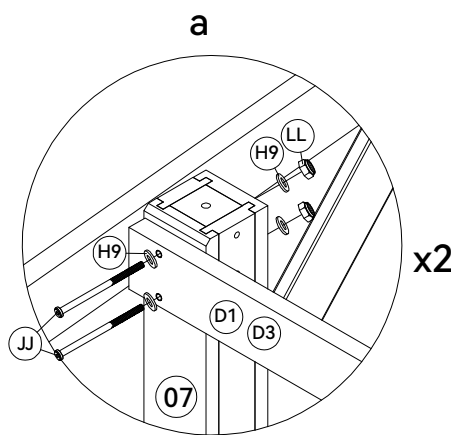
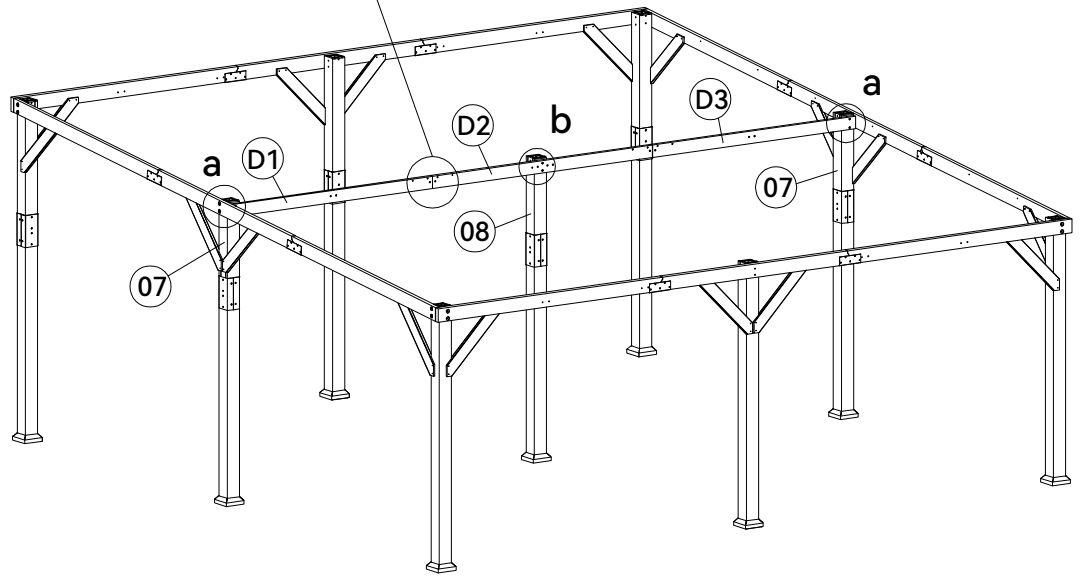
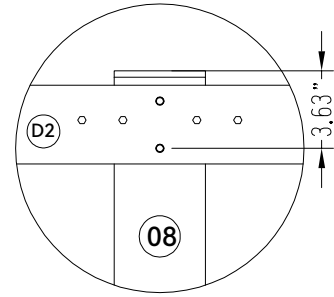

The screw hole is located at the bottom.



Install center beams (D1), (D2), and (D3). Ensure narrow side screw holes face downward. First install side beams (D1) and (D3), securing with screw (JJ)+washer (H9) on one side and nut (LL)+washer (H9) on the other. Then install center beam (D2) the same way.

|  |   |  |
|--|---|--|
| <p>(LL) x6</p>  <p>M8</p> | <p>(H9) x12</p>  <p>M8</p> | <p>(JJ) x6</p>  <p>M8x170</p> |
|--|---|--|

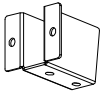

19

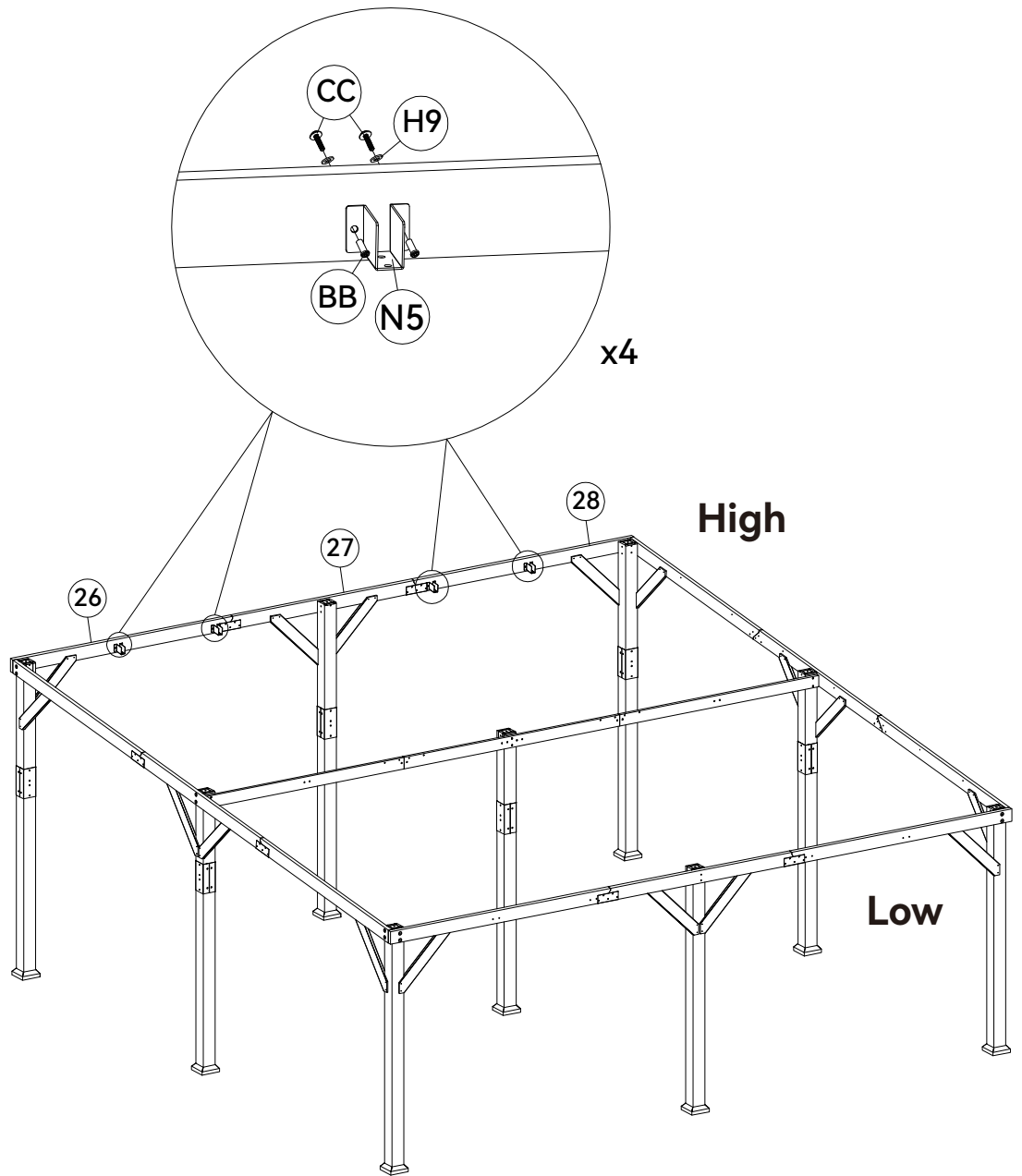

N5 x4



Install component (N5) on the high beam side. One side uses nut, the other side uses screw (CC)+washer (H9).

|  |   |   |
|--|---|---|
| <p>H9 x8</p>  <p>M8</p> | <p>BB x8</p>  <p>M6x20</p> | <p>CC x8</p>  <p>M6x30</p> |
|--|---|---|

20

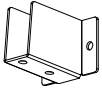

N6 x4

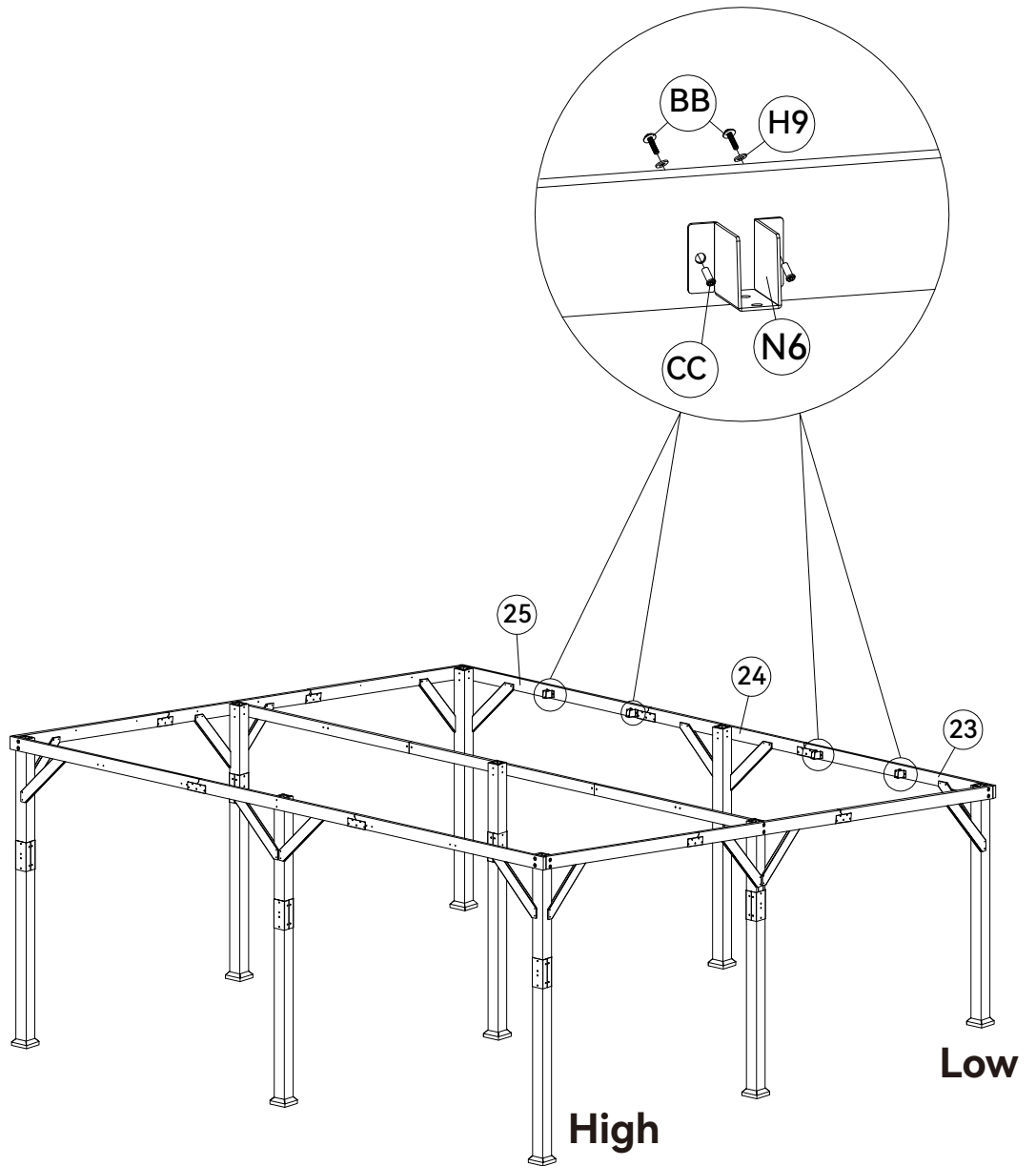

Install component (N6) on the low beam side. One side uses nut, the other side uses screw (CC)+washer (H9).

H9 x8



M8

BB x8



M6x20

CC x8

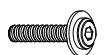

M6x30

# 21



**B1** x4



**Y3** x4



**B2** x4

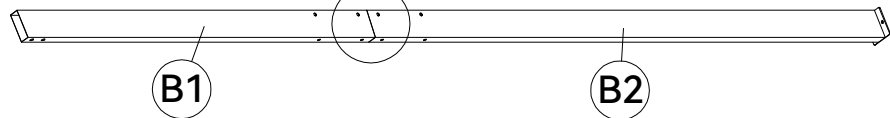
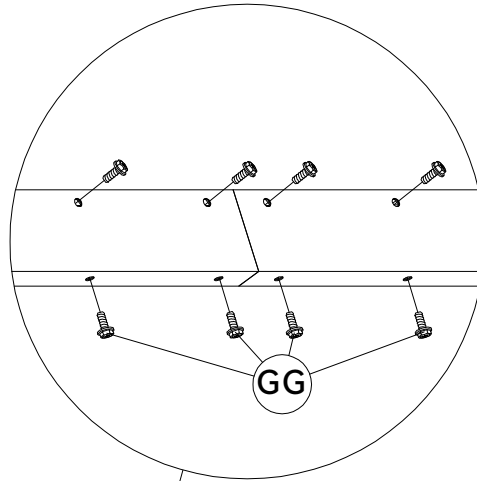
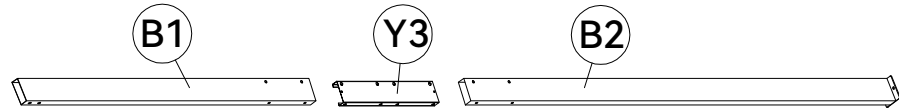

**x4**

As shown, place parts (B1), (Y3), and (B2). Loosely install screws (GG) first, then fully tighten after assembly.

**Note: Loosely install the screws first, and then tighten them all after assembly is complete.**

**GG** x32



**M6x15**

22

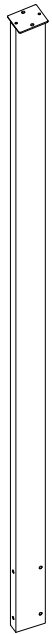

(B3) x4



(Y3) x4



(B4) x4

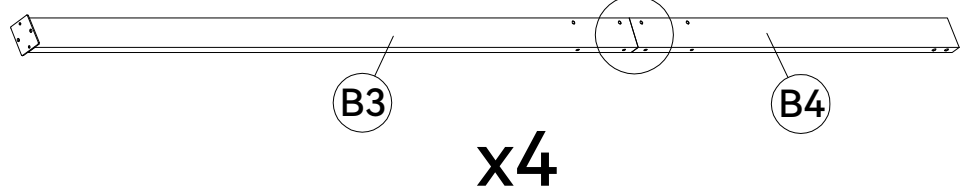
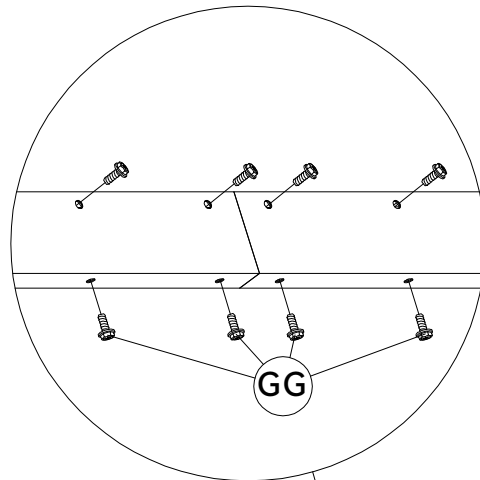
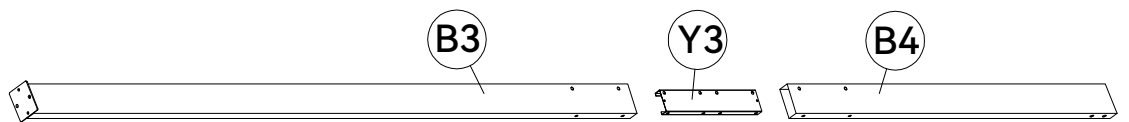

As shown, place parts (B3), (Y3), and (B4). Loosely install screws (GG) first, then fully tighten after assembly.

**Note: Loosely install the screws first, and then tighten them all after assembly is complete.**

(GG) x32



M6x15

23



(B5) x2



(Y3) x2



(B6) x2

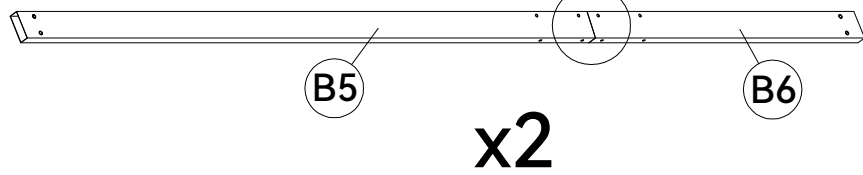
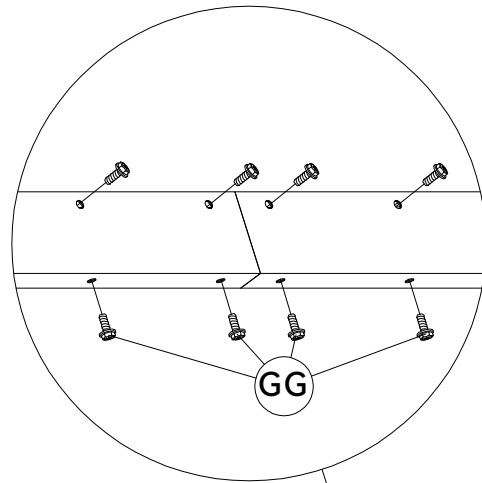
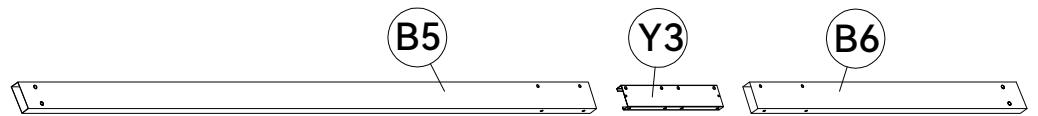

As shown, place parts (B5), (Y3), and (B6). Loosely install screws (GG) first, then fully tighten after assembly.

**Note: Loosely install the screws first, and then tighten them all after assembly is complete.**

(GG) x16



M6x15

24



B8 x2



Y3 x2



B7 x2

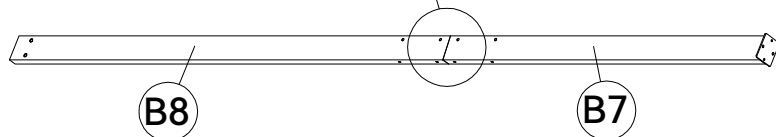
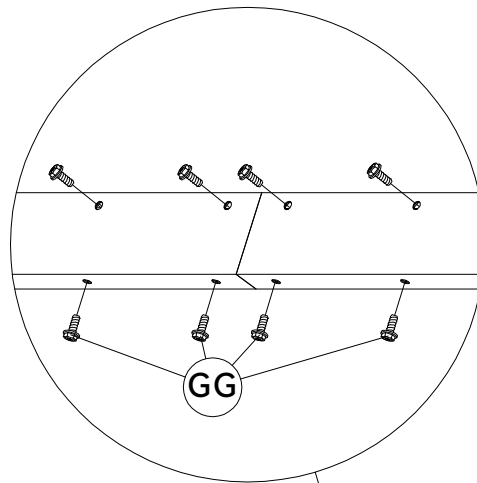
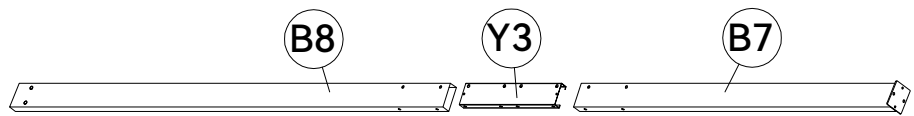

x2

As shown, place parts (B8), (Y3), and (B7). Loosely install screws (GG) first, then fully tighten after assembly.

**Note: Loosely install the screws first, and then tighten them all after assembly is complete.**

GG x16





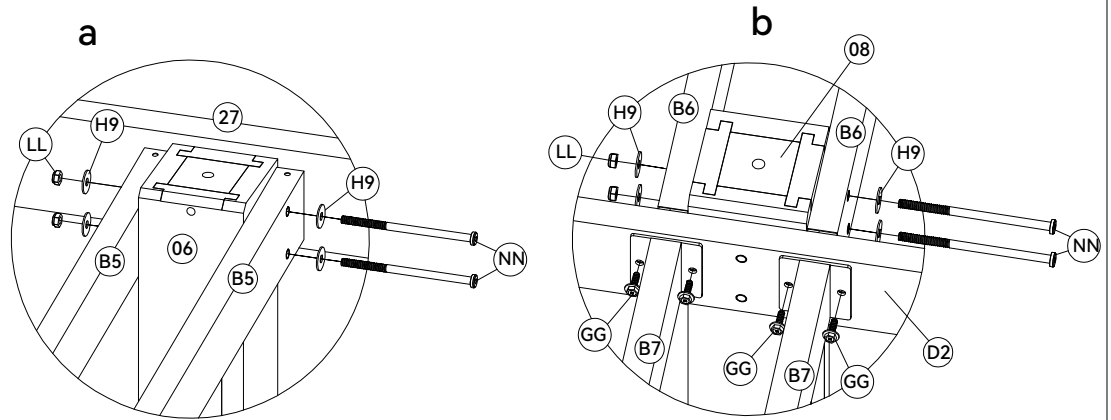

M6x15

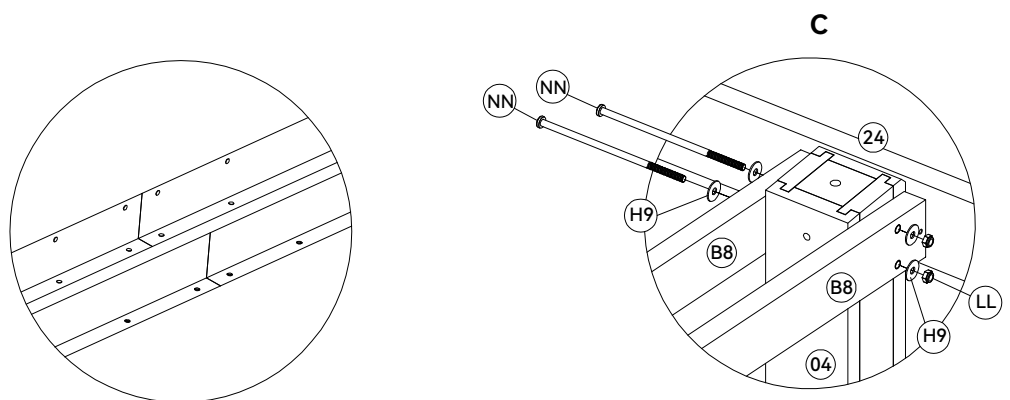
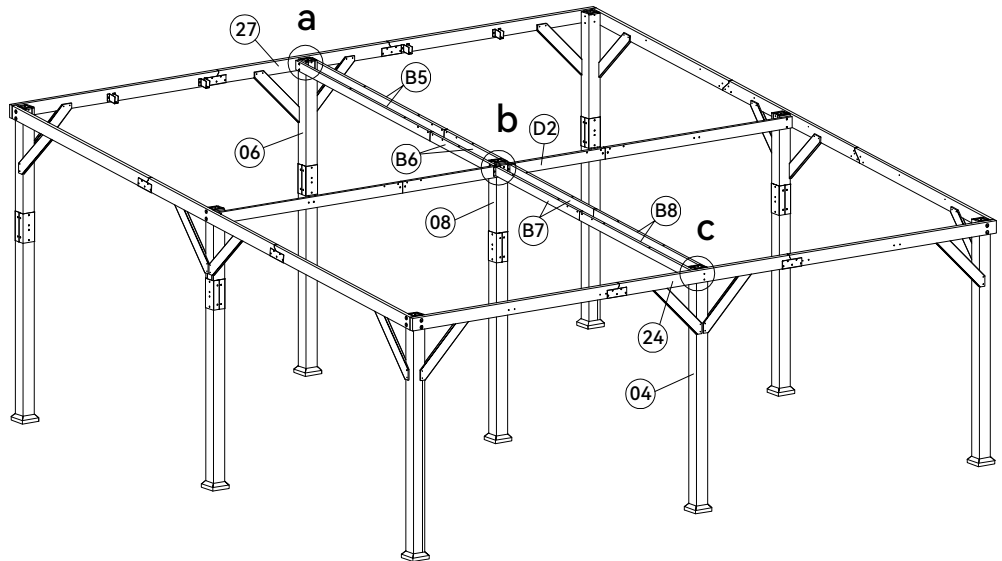

Ensure narrow side screw holes face downward. Install (B5) using screw (NN)+washer (H9) on one side and nut (LL)+washer (H9) on the other. Repeat for (B6) and (B8). Install (B7) with screw (GG).



**Note: The screw holes are at the bottom!**

|   |  |   |  |
|---|--|---|--|
| <p>(GG) x4</p>  <p>M6x15</p> | <p>(LL) x6</p>  <p>M8</p> | <p>(H9) x12</p>  <p>M8</p> | <p>(NN) x6</p>  <p>M8x200</p> |
|---|--|---|--|

The screw holes at the connection points of (B1) and (B2), as well as (B3) and (B4), are located at the bottom.

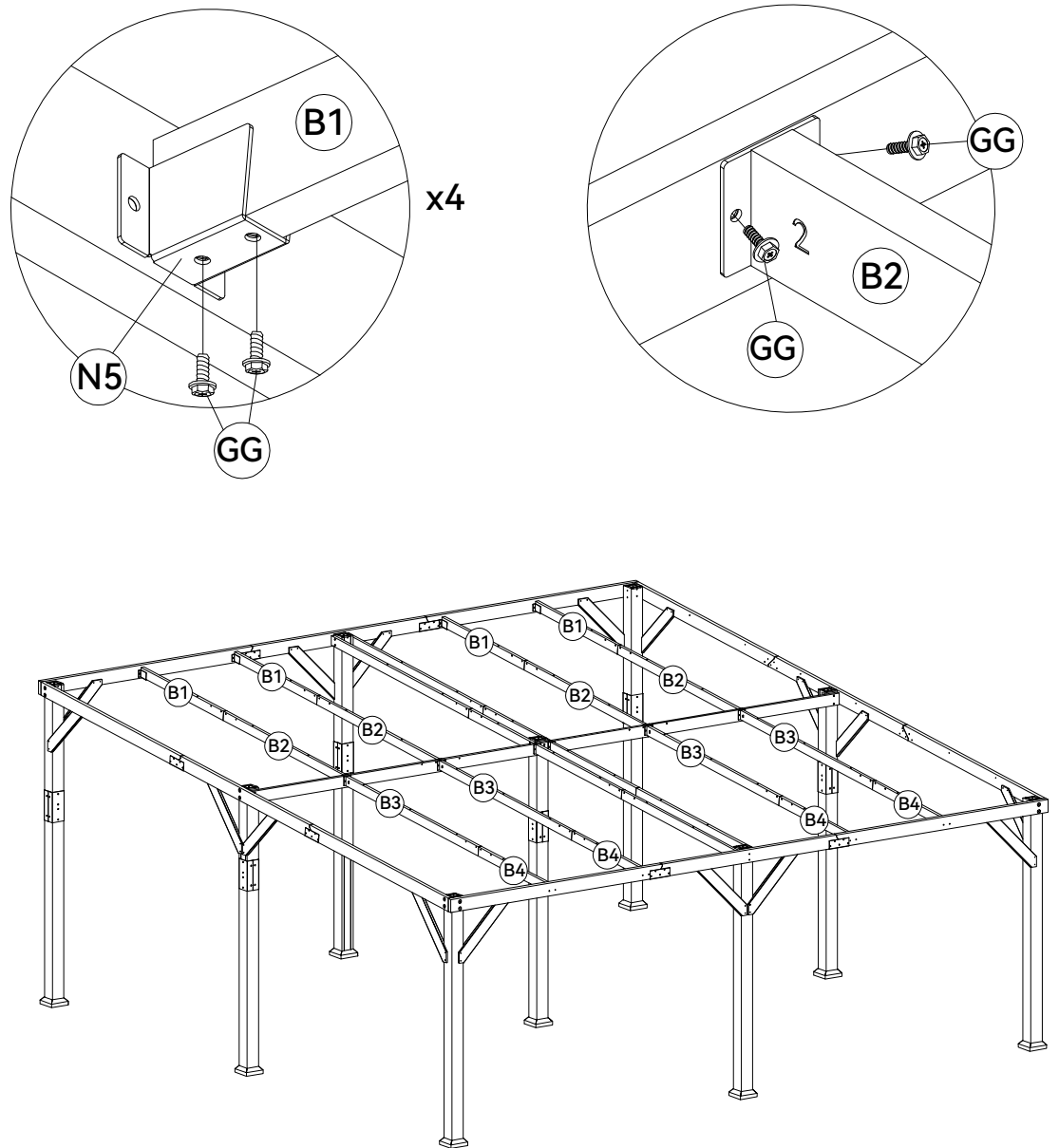

Ensure narrow side screw holes face downward. Place (B1) onto (N5) and secure with screw (GG). Lock screw (GG) on side with number (2). Install (B3) and then place (B4) onto (N6) and secure with screw (GG).

**GG** x32



**M6x15**

27



C1 x8

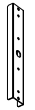

Y2 x8



C2 x4

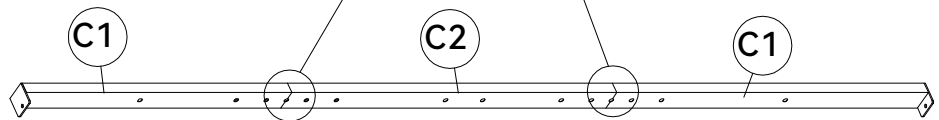
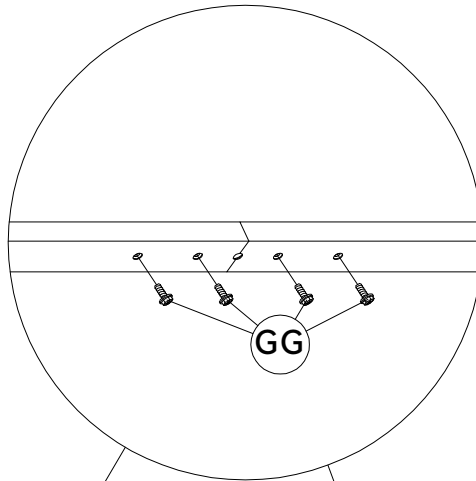
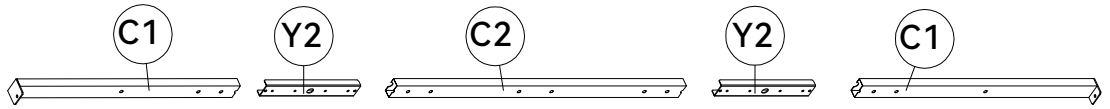

x4

As shown, place parts (C1), (Y2), (C2), (Y2), and (C1). Loosely install screws (GG) first, then fully tighten after assembly.

GG x32



M6x15

28



C3 x6



Y2 x6

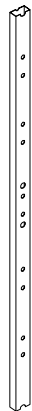

C4 x3

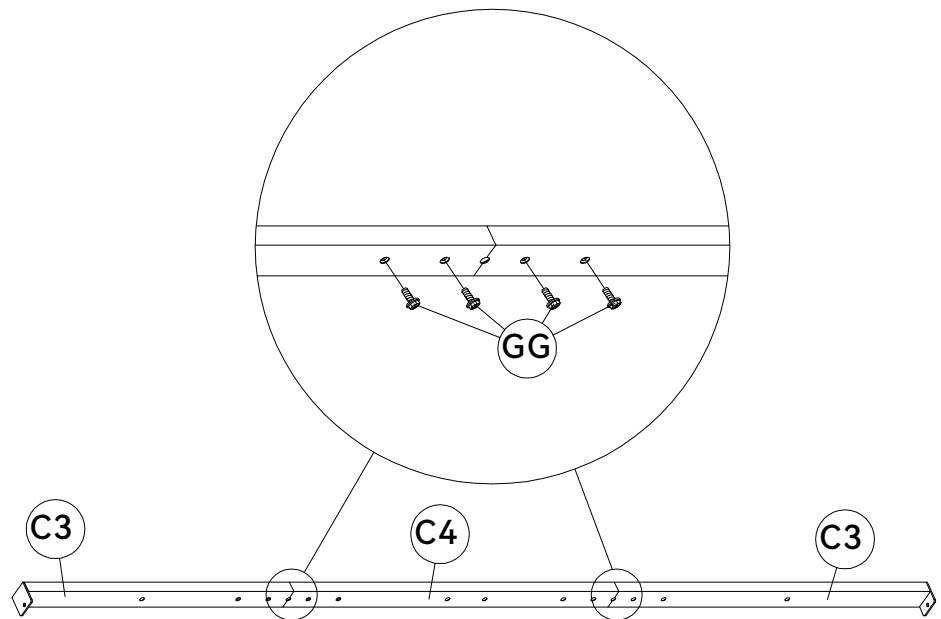
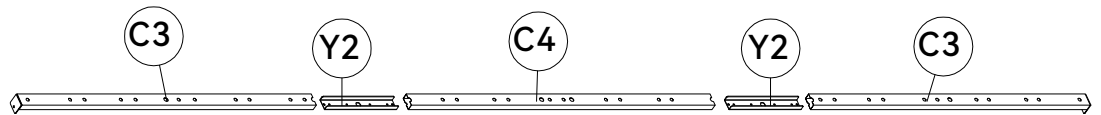

x3

As shown, place parts (C3), (Y2), (C4), (Y2), and (C3). Loosely install screws (GG) first, then fully tighten after assembly.



GG x24

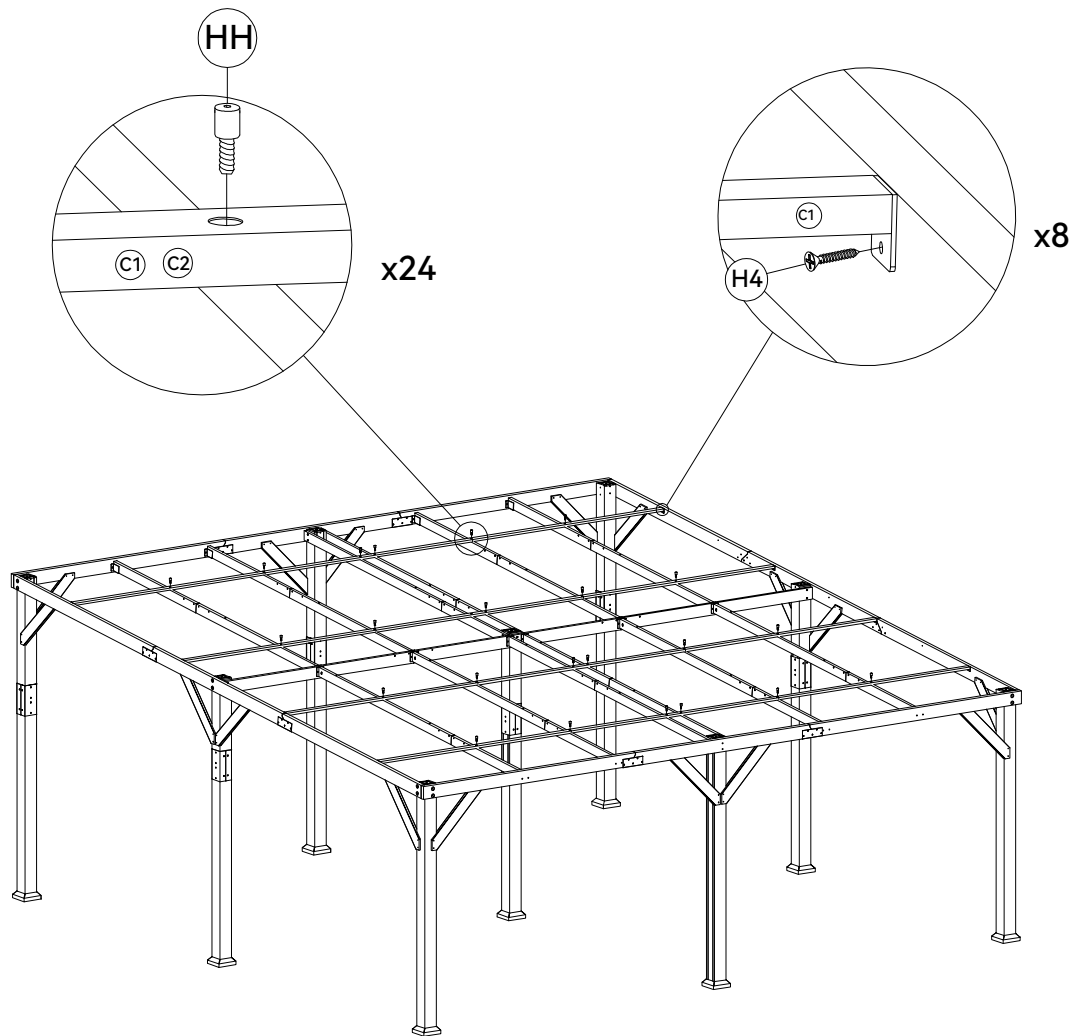
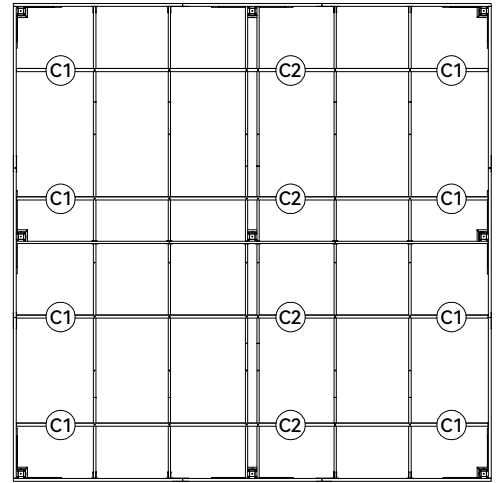

M6x15



Install (C1) and (C2) from top down using countersunk screws (HH).  
Install self-tapping screws (H4) on the side of (C1).

|   |  |
|---|--|
| <p><b>H4 x8</b></p>  <p><b>M5x25</b></p> | <p><b>HH x24</b></p>  <p><b>M6x35</b></p> |
|---|--|

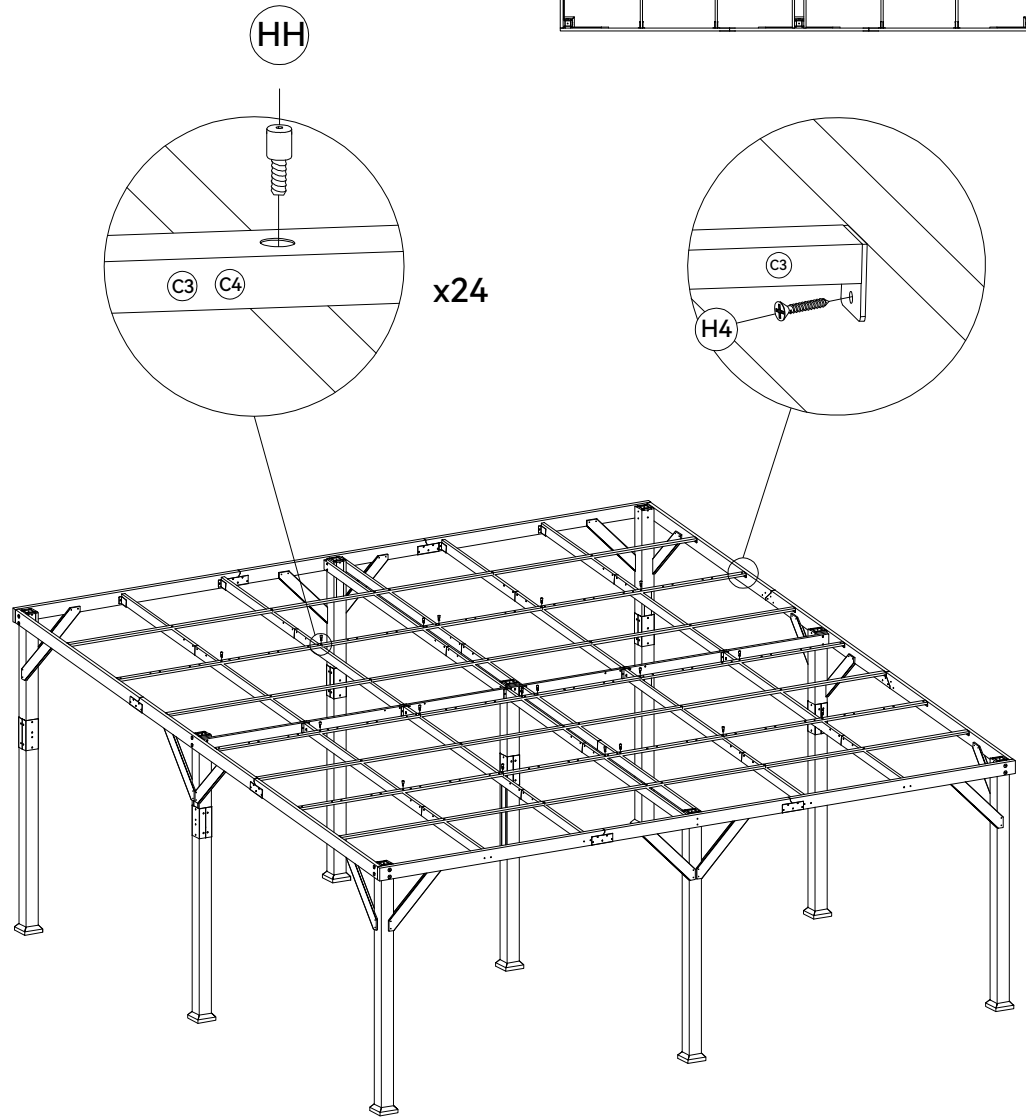
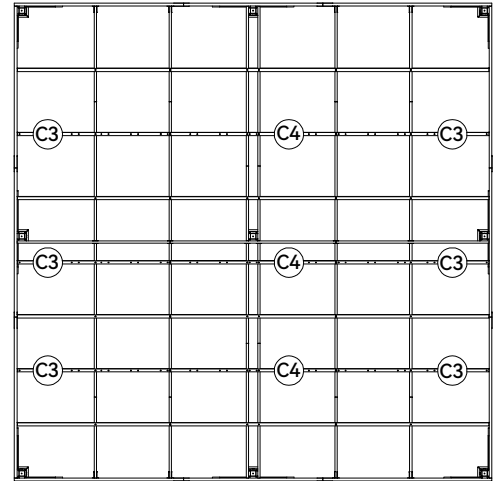

Install (C3) and (C4) from top down using countersunk screws (HH).  
Install self-tapping screws (H4) on the side of (C3).

H4 x6



M5x25

HH x18

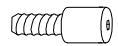

M6x35

# 31

1. Stack and assemble (Q4), (Q3), (Q2), (Q1) from bottom to top.

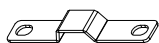

(S) x45



(Q3) x16

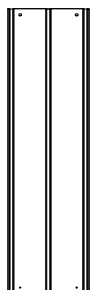

(Q4) x16

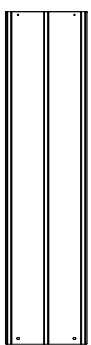

(Q1) x16

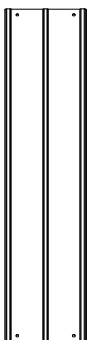

(Q2) x16

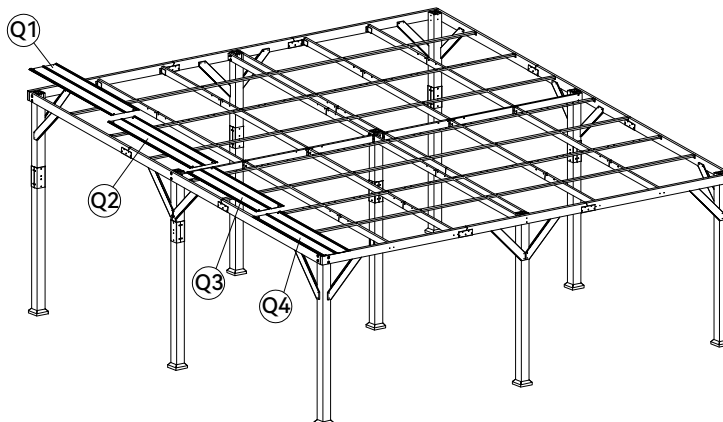

2. Lay out (Q4), (Q3), (Q2), (Q1), and (S) flat.

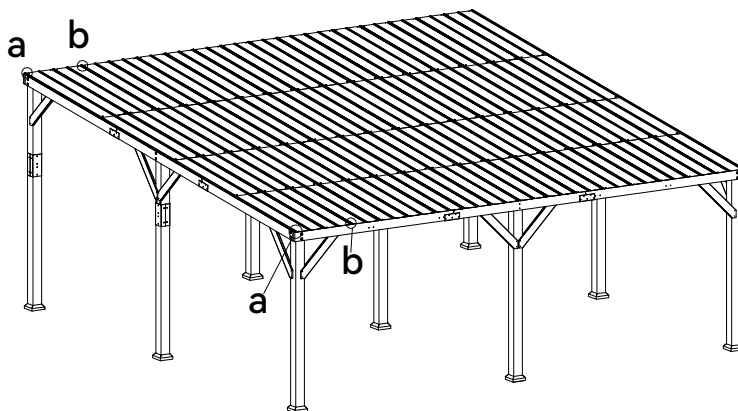
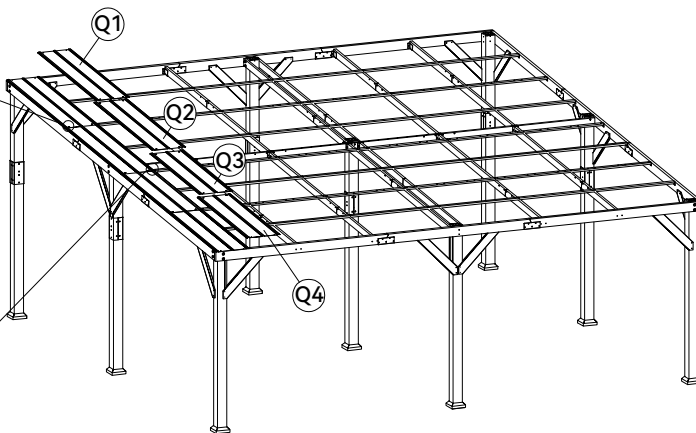
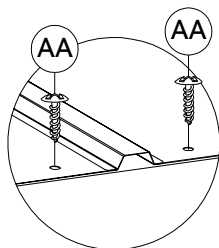
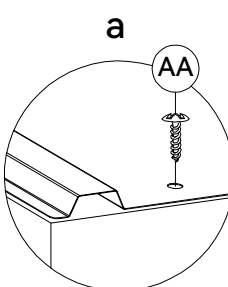
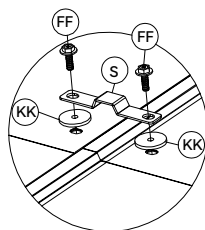
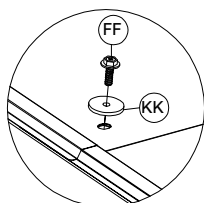

Use screw (FF) + washer (KK) on the outermost ends. Between cover plates, install pressure strips (S) with washer (KK) underneath and screw (GG) on top. Use self-tapping screw (AA) on top and bottom holes.

(KK) x96



(AA) x64



M4x16

(FF) x96



M6x20

32



P1 x1



P3 x1



P2 x1



P5 x2



P4 x1

Install (P1), (P2), (P3), (P4), and (P5) using screws (AA). Ensure (P3) is flush with corner of (23).

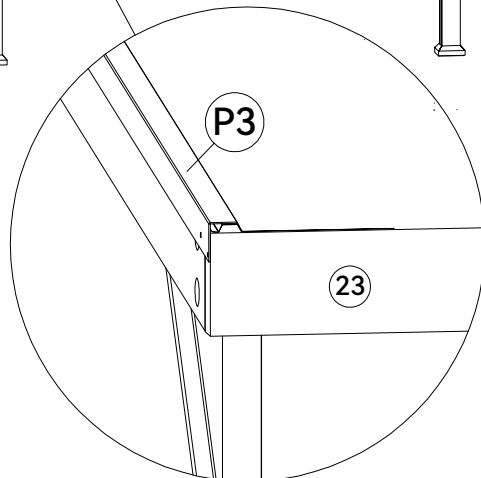
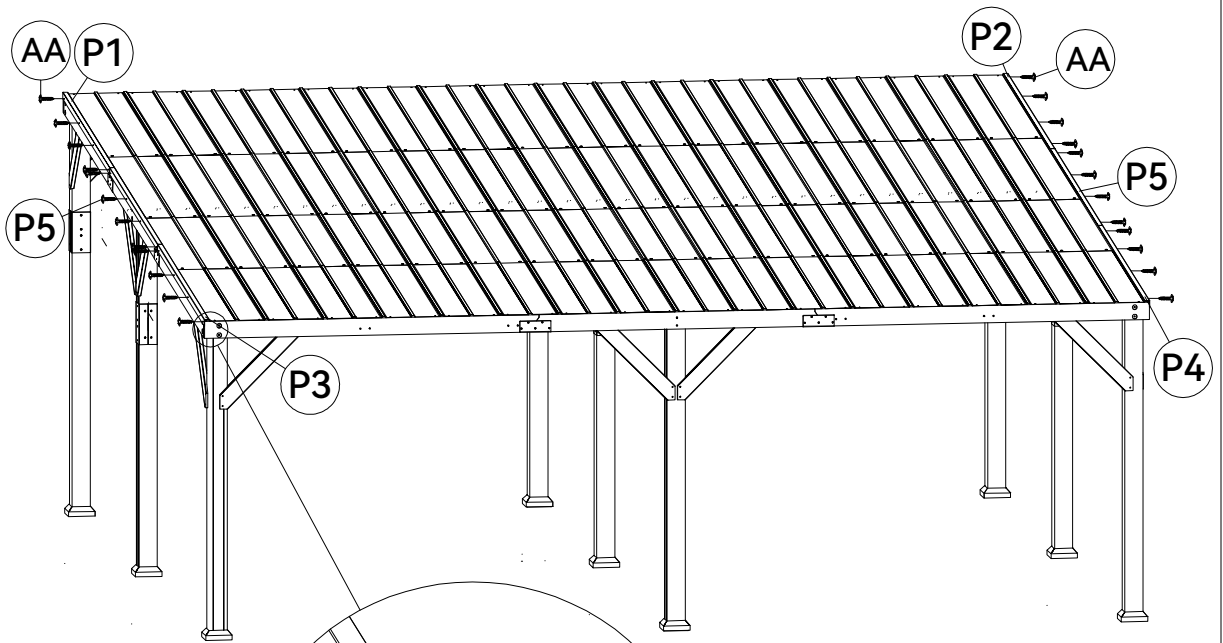
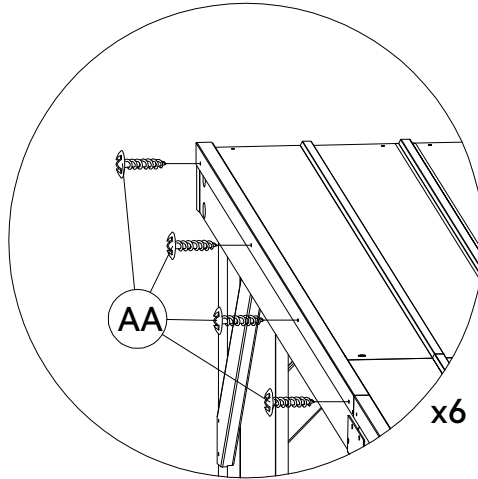

AA x24



M4x16

Note: The corner of P3 and 23 is flush!

33



(R1) x1



(R2) x1



(R3) x1

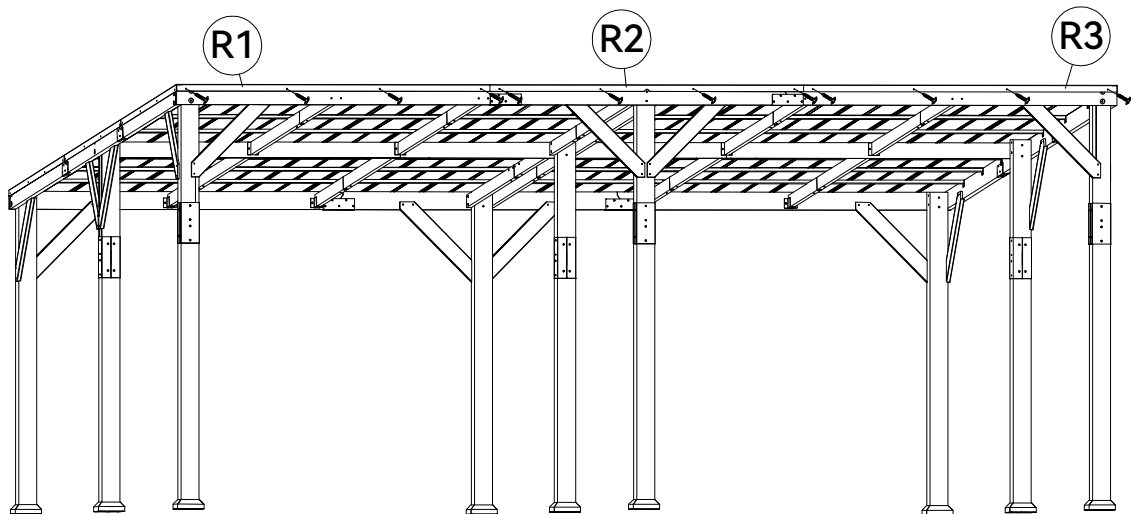
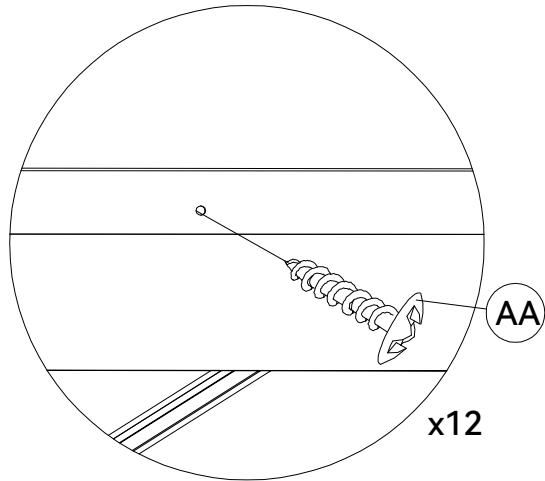

Install (R1), (R2), and (R3) using screws (AA).

(AA) x12



M4x16

34



(R4) x1



(R5) x1



(R6) x1

Install (R4), (R5), and (R6) using screws (AA). Ensure (P3) is flush with the corner of (R4).

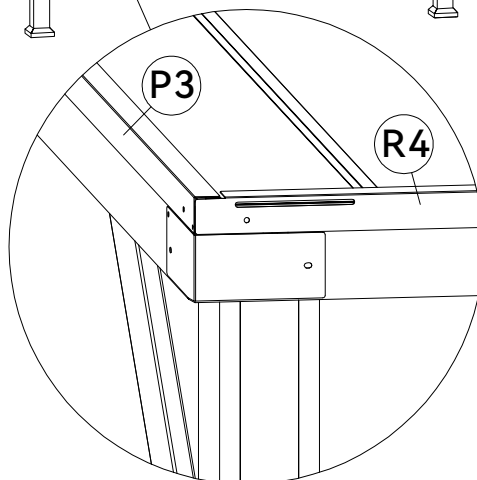
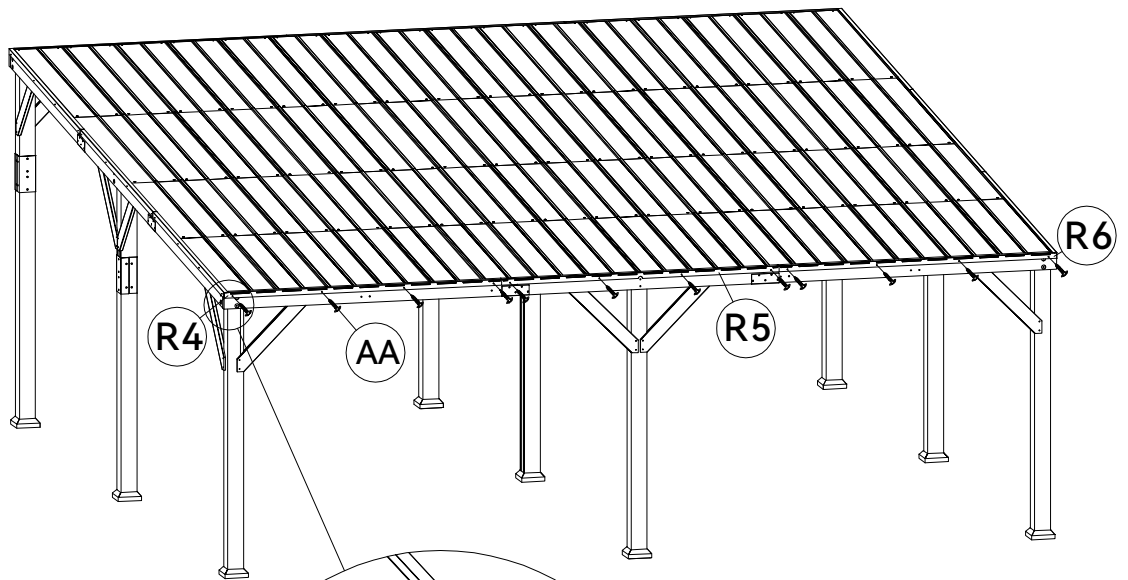
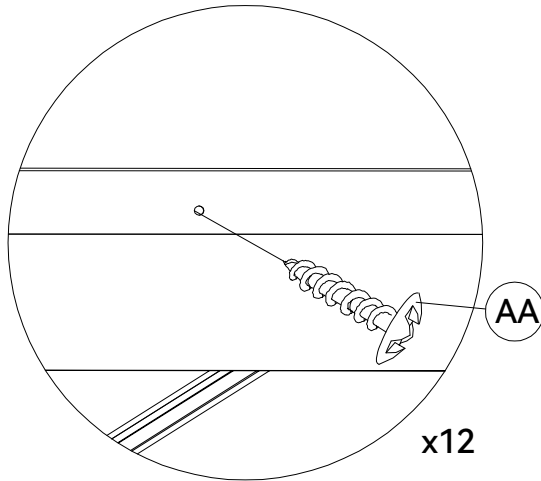

(AA) x12



M4x16

35

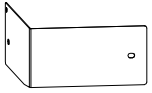

Y4 x1

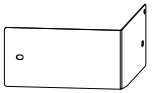

Y5 x1

Install (Y4) and (Y5) using screws (AA).

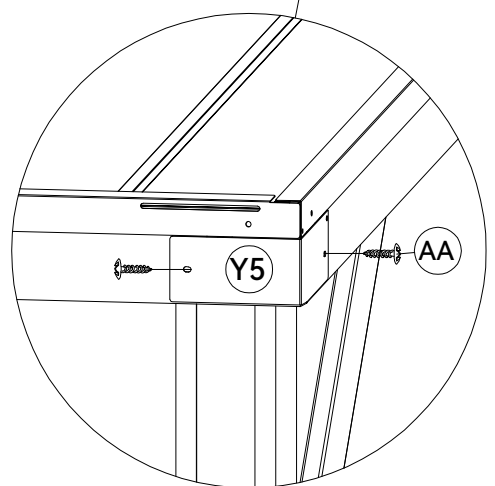
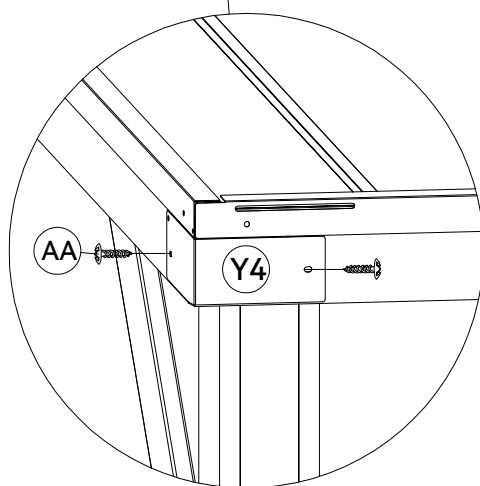
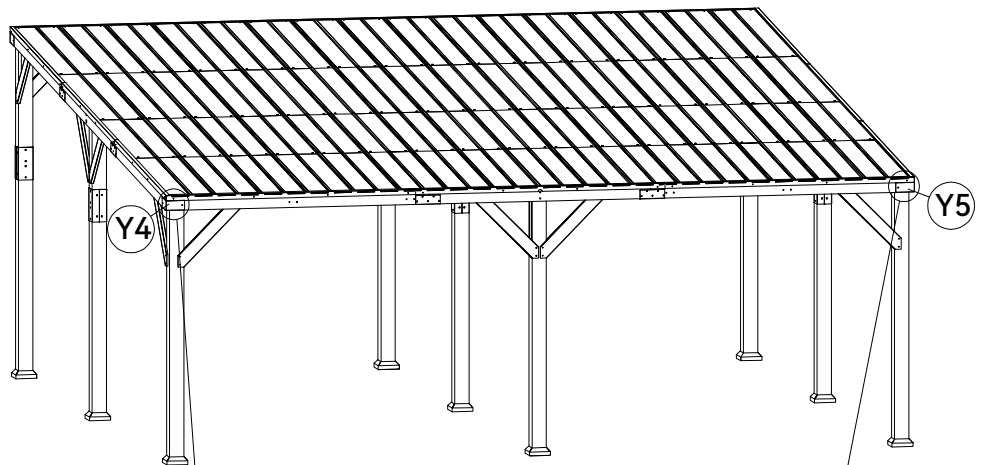

AA x4



M4x16

36

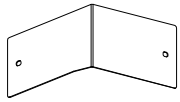

Y6 x1

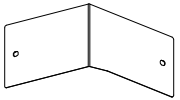

Y7 x1

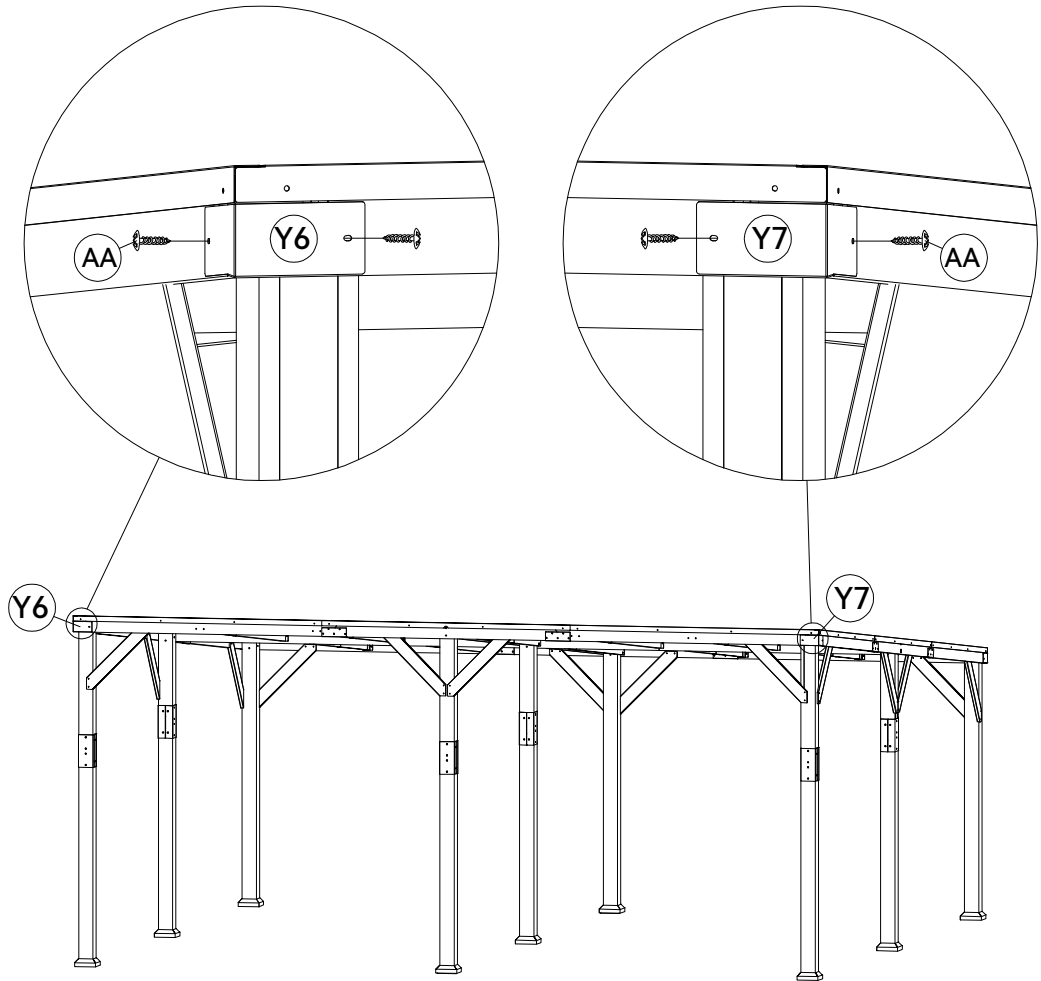

Install (Y6) and (Y7) using screws (AA).

AA x4



M4x16

As shown in the diagram, secure the carport/gazebo.

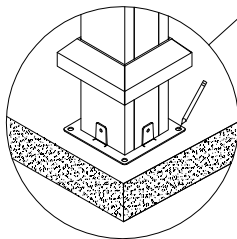
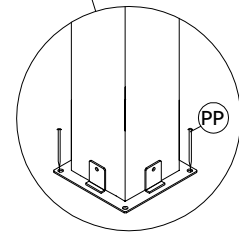
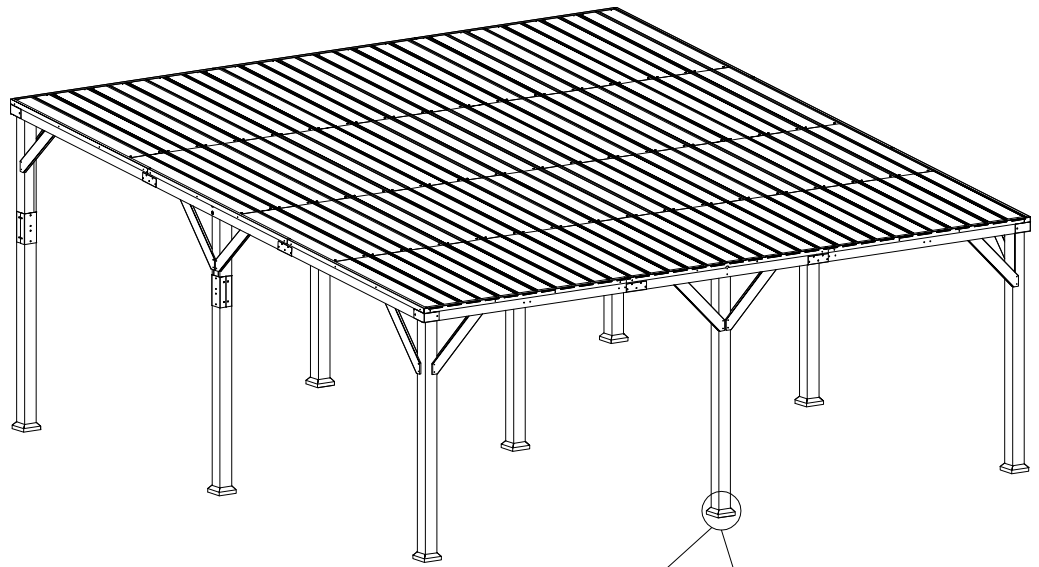

Position

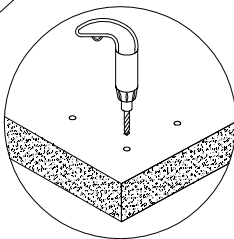

Drill holes

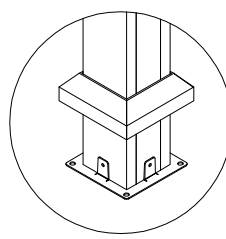

Place components

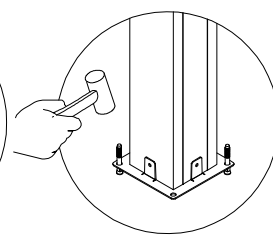

Insert screws

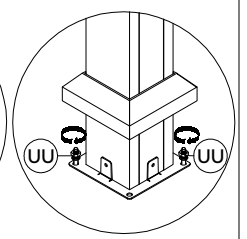

Tighten

UU x18

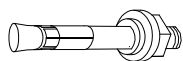

M6x80

PP x18

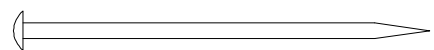

D8x180

# | Carport

BC21L7-1C1A0

V1.0