

# Wall Lighting

## TOOLS AND MATERIALS REQUIRED:

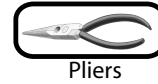
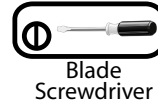

Wiring supplies  
as required by  
electrical code

## SAFETY PRECAUTIONS:

1. TURN OFF ELECTRICAL POWER BEFORE STARTING INSTALLATION OF LIGHT FIXTURE.  
DO NOT REMOVE INSULATION FROM FIXTURE.
2. THIS PRODUCT MUST BE INSTALLED IN ACCORDANCE WITH THE APPLICABLE INSTALLATION CODE BY A PERSON FAMILIAR WITH THE CONSTRUCTION AND OPERATION OF THE PRODUCT AND THE HAZARDS INVOLVED.

**NOTE: Product May Not Look Exactly As Shown In Figures.**

## INSTALLATION:

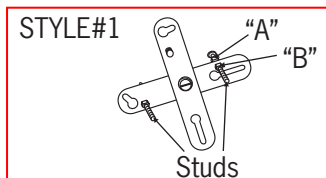

1. **Note:** Refer to the mounting bracket style that matches the bracket that is included with your fixture.

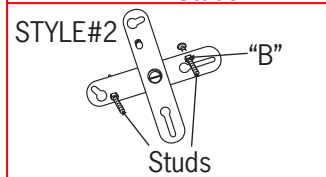

**Style#1 (Non-Threaded holes)**  
Loosen hex nut "A" and "B". Adjust stud so it clears the fixture once assembled. Hold in place with "A" and lock in place with "B".

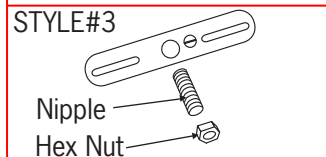

**Style#2 (Threaded holes)**  
Loosen "B". Adjust stud to desired length and lock in place with "B".

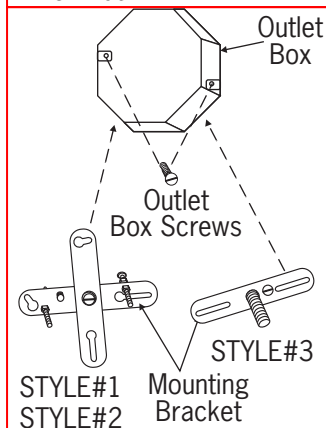

**Style#3 (Nipple)**  
Attach nipple to mounting bracket and adjust until it will clear fixture when assembled. Lock in place using the hex nut.

2. Mount the mounting bracket to outlet box using outlet box screws. Make sure the studs or nipple on the mounting bracket are facing out from the outlet box.

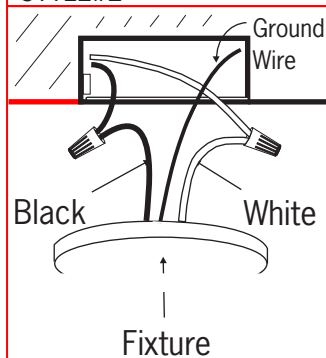

3. Connect ground wire on fixture to outlet box ground screw. Connect black wire from fixture to black wire in outlet box and connect the white wire from fixture to white wire in outlet box.

**Note:** Do not disconnect wires that are already connected.

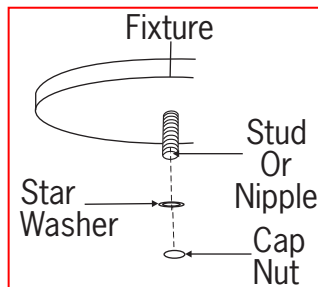

4. Tuck electrical wires into outlet box and position fixture over studs or nipple on mounting bracket assembly. Secure fixture in place with star washer(s) and cap nut(s).

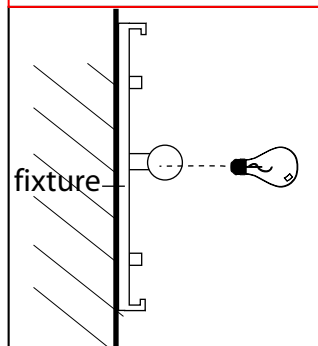

5. Install proper bulb type and wattage.

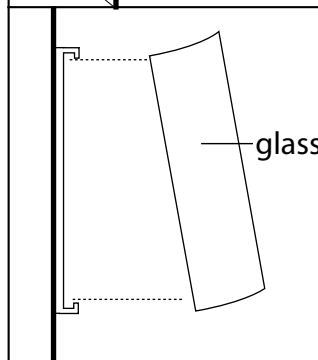

6. Slide glass into the slots one at a time.