

# ASSEMBLY INSTRUCTIONS

---

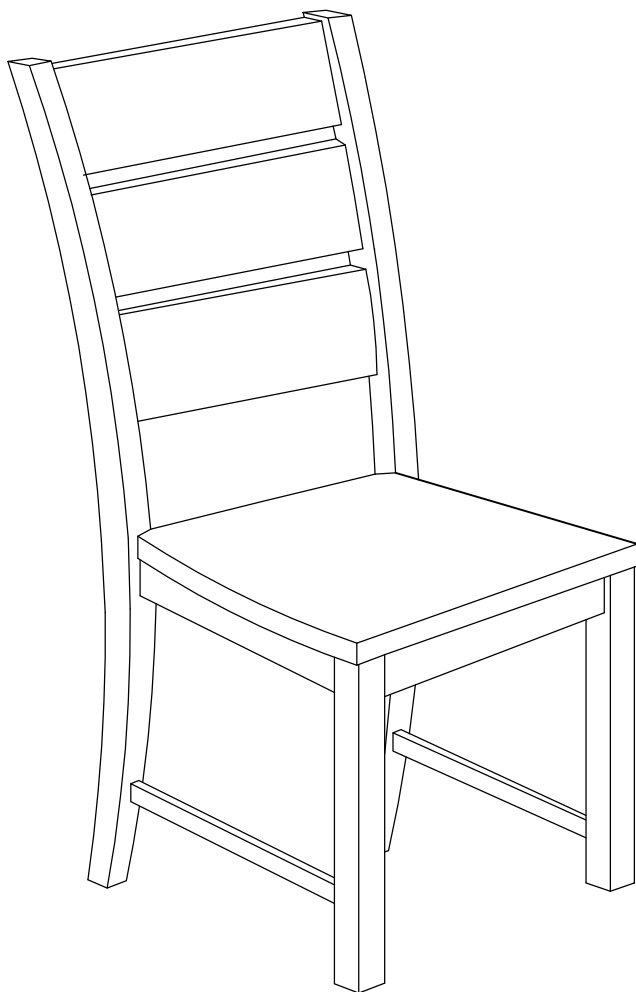

## TOOLS REQUIRED

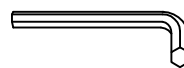

**Allen Wrench**

(Included)



**Phillips  
Screwdriver**

(Not Included)



**2 - Persons  
Recommended**

## ASSEMBLY RATING



EASY —————> DIFFICULT

The Assembly Rating is a 5-point system showing the level of effort needed to assemble a specific product.

Thank you for your purchase!

We hope you enjoy this new addition to your home for many years to come.

Our commitment to providing quality products does not simply end when you purchase our product. We fully stand behind our products from start to finish.

---



## **CHECK BEFORE STARTING**

**Are you missing anything?**

Double-check all parts, hardware and accessories listed on Page 6 are accounted for.

**Check out our Quick Tips!**

We recommend reviewing the pre-assembly handouts. Even experts need a refresher now and then!

**Prep Time!**

Please review the assembly instructions and all diagrams prior to assembling. Arrange parts as recommended on Page 7 and group identical hardware together to make assembling easier.

# PRE ASSEMBLY INTRODUCTION

We understand building ready-to-assemble furniture can be a challenging experience for some. To help avoid confusion, we have provided some helpful tips that may speed up the process.



## Teamwork

ALWAYS have at least two people to help with transporting and assembling the product to avoid potential injury and/or damage.



## Suitable Location

Assembling near the area of the intended location is highly recommended.



## Sufficient Space

Make sure you have enough space to move around during the assembly.



## Avoid Scratches

Use cardboard, blankets or a carpeted area while assembling furniture to prevent scratches.



## Flat Surface

Make sure the furniture rests on a flat and level surface with each leg evenly touching the floor.

# ASSEMBLY AND CARE ADVICE



**FAILURE TO FOLLOW THE GUIDELINES BELOW MAY RESULT IN INJURY AND/OR PROPERTY DAMAGE.**



Position each part correctly and insert screws or bolts into their respective holes.



Turn clockwise to tighten and only tighten when step is completed or when instructed to do so.



Use the appropriate hand tools or power tools for assembly. Select steps, such as tightening screws and/or bolts, may require hand tools to avoid causing damage during assembly.



Save the instructions and store any supplied tools for later maintenance.



After two weeks, check and tighten any loose hardware and repeat again every six months thereafter.

**IT IS THE USER'S RESPONSIBILITY TO MAINTAIN THE FURNITURE. THE HARDWARE MAY LOOSEN OVER TIME AND MAY CAUSE THE FURNITURE TO BE WOBBLY AND UNABLE TO SUPPORT ITS INTENDED WEIGHT CAPACITY. THIS MAY LEAD TO COLLAPSE AND MAY CAUSE SERIOUS INJURY.**

# CHAIR

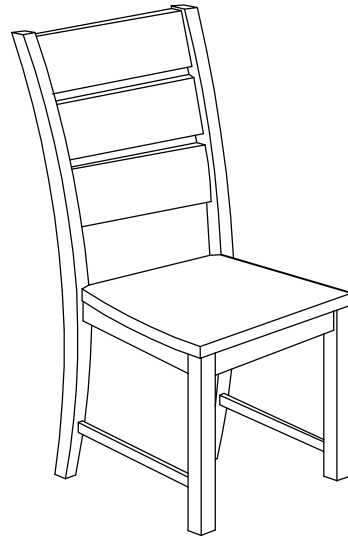
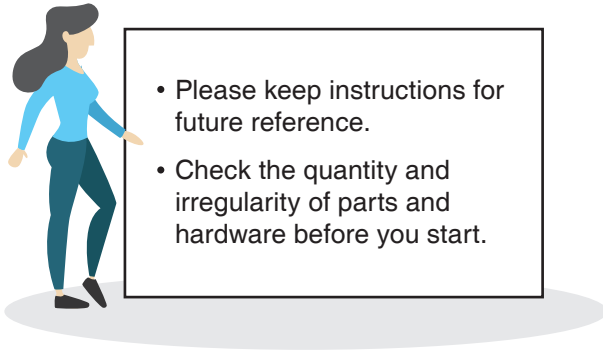

## PARTS

#1 1pc

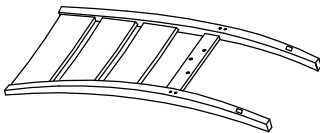

Backrest

#2 1pc

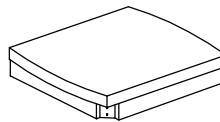

Wooden Seat Box

#3 2pcs

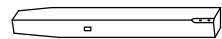

Front Leg

#4 1pc

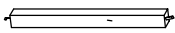

Left Side Rail (L)

#5 1pc



Right Side Rail (R)

## HARDWARE

#A 3pcs

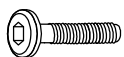

35mm JCBC BOLT

#B 4pcs

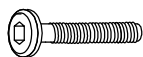

60mm JCBC BOLT

#C 4pcs

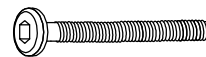

80mm JCBC BOLT

#D 11pcs



M6 Lock Washer

#E 11pcs



M6 Flat Washer

#F 4pcs



CB Screw M4 x38mm

#G 1pc



Allen Wrench

# ASSEMBLY INSTRUCTIONS

# 1

Part (#1) x 1pc

Part (#2) x 1pc

Hardware (#A) x 3pcs

Hardware (#D) x 3pcs

Hardware (#E) x 3pcs

1. Place the wooden seat box (#2) on backrest (#1) and align the 3 screw holes on the rear seat box (#2) to the screw holes on bottom rail of backrest (#1).
2. Insert JCBC bolts (#A) fitted with spring washer (#D) and flat washer (#E) into the screw holes by using Allen Key (#G).

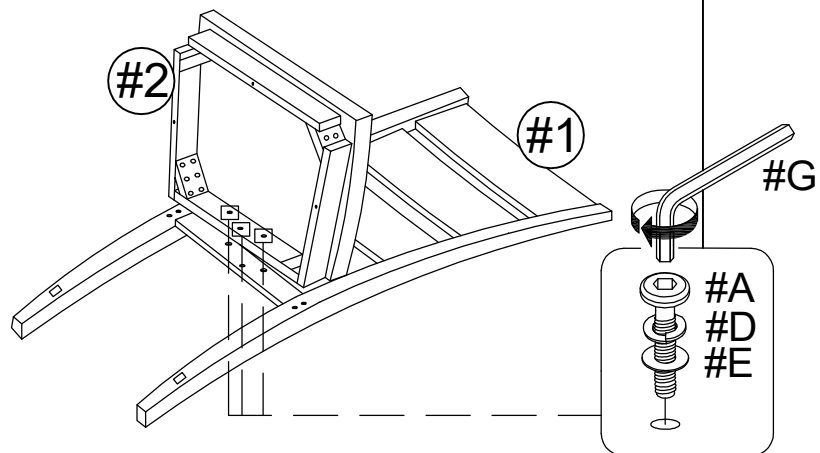

# 2

Hardware (#C) x 4pcs

Hardware (#D) x 4pcs

Hardware (#E) x 4pcs

- Insert JCBC bolts (#B) fitted with spring washer (#D) and flat washer (#E) into the screw holes on left and right of backrest by using Allen Key (#G).

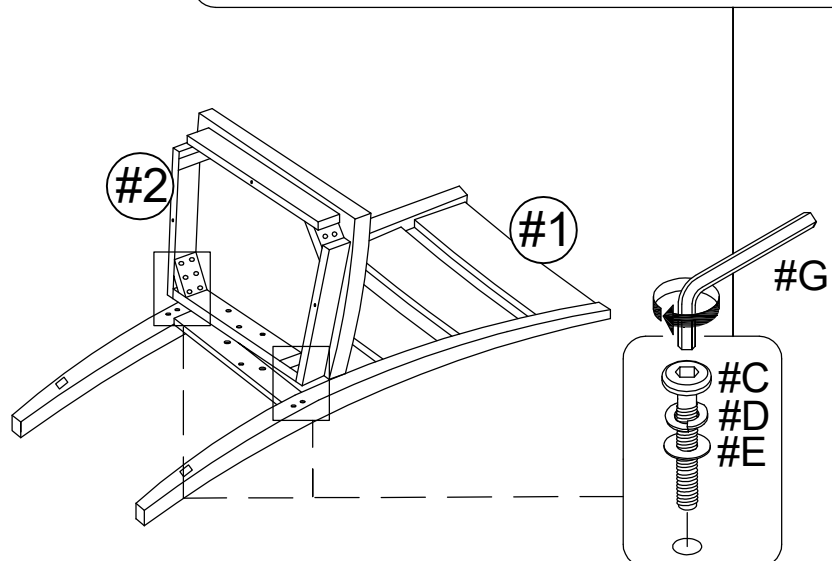

# ASSEMBLY INSTRUCTIONS

## 3

Part #3 x 2pcs

Part #4 x 1pc

Part #5 x 1pc

Hardware #B x 4pcs

Hardware #D x 4pcs

Hardware #E x 4pcs

Hardware #F x 4pcs

1. Attach side rails (#4) & (#5) to the backrest then place front leg (#3) to the wooden seat box (#2) and side rails (#4) & (#5).
2. Insert JCBC bolts (#C) fitted with spring washer (#D) and flat washer (#E) into the screw holes by using Allen Key (#G).
3. Fasten CB screw (#F) on side rails (#4) & (#5) to backrest (#1) and front leg (#3).

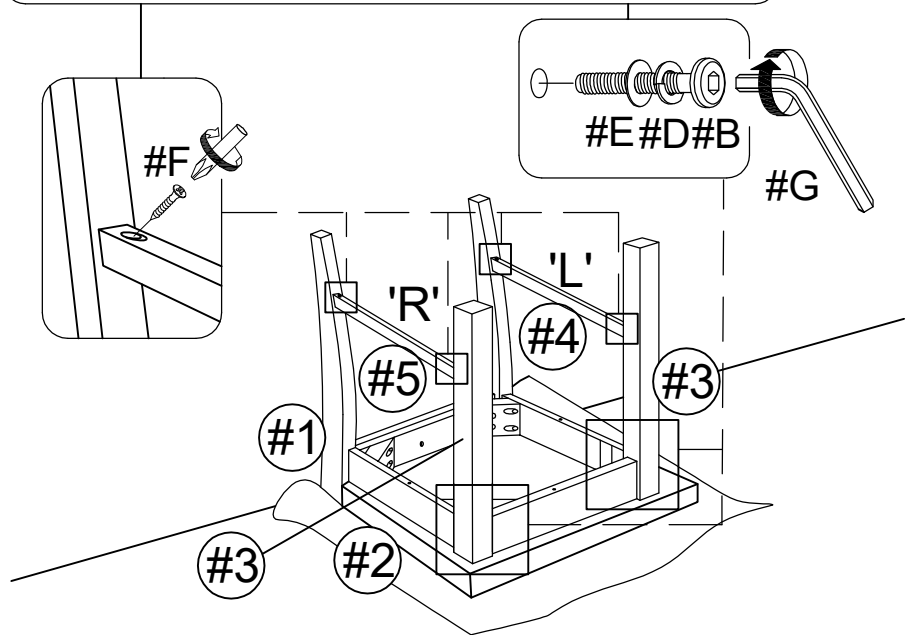

## 4

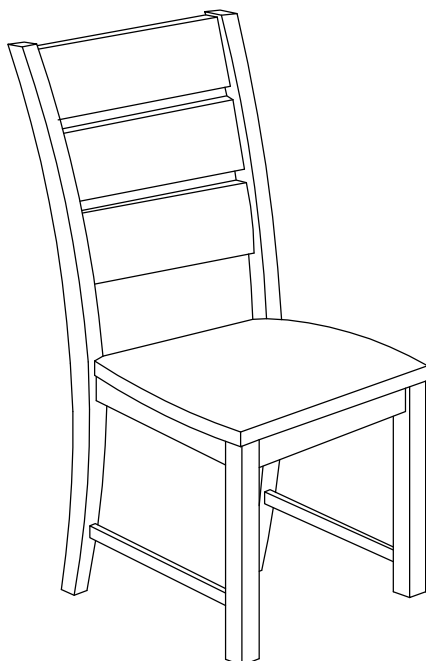

x 2

### ASSEMBLY COMPLETED



Please ensure the furniture rests on an even and flat surface. If the product wobbles or feels loose, double-check all bolts and/or screws are properly tightened and secured.



#### Keep this handy!

Please retain this instruction manual and any order-related information for future reference.