

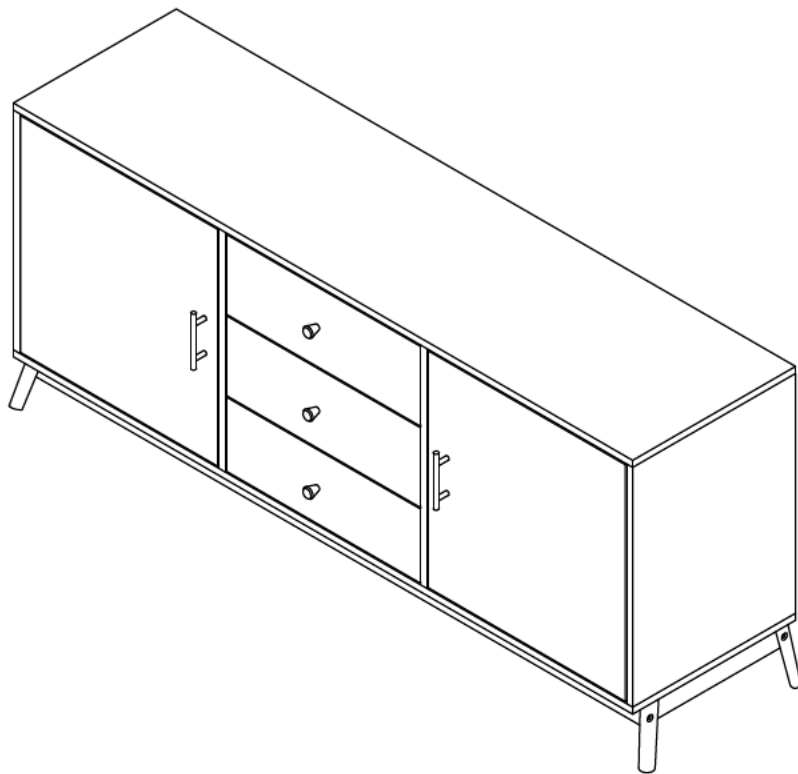

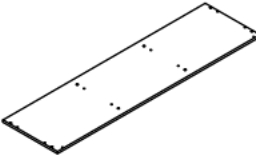

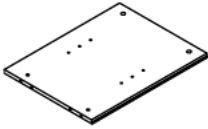

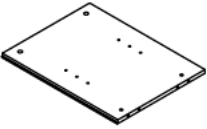

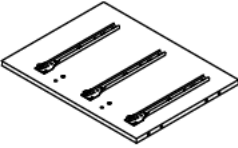
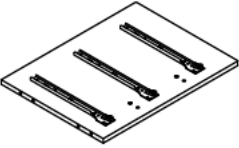
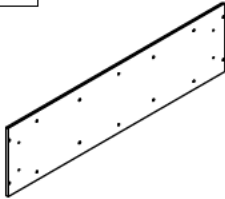
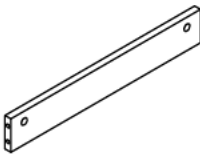
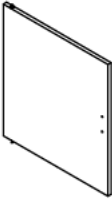
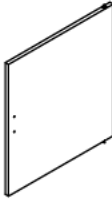
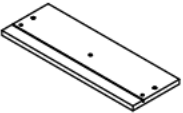
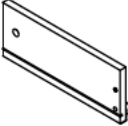
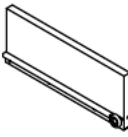
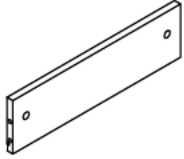
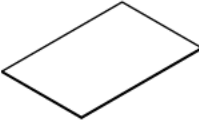
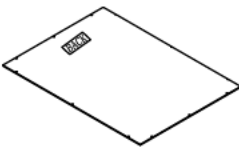
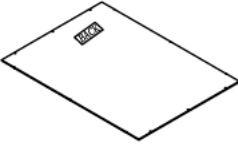
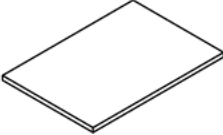
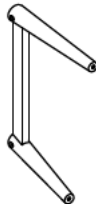
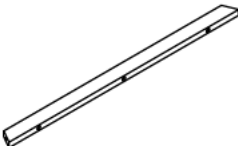

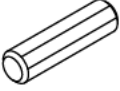

# Sideboard

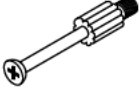

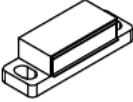
# PART LIST

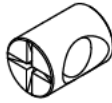
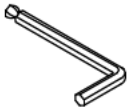
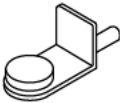
<p><b>A</b></p> 	<p><b>B</b></p> 	<p><b>C</b></p> 	<p><b>D</b></p> 	<p><b>E</b></p> 
<p>Top Panel 1 PC</p>	<p>Left Panel 1 PC</p>	<p>Right Panel 1 PC</p>	<p>Left Partition Panel 1 PC</p>	<p>Right Partition Panel 1 PC</p>
<p><b>F</b></p> 	<p><b>G</b></p> 	<p><b>H</b></p> 	<p><b>I</b></p> 	<p><b>J</b></p> 
<p>Bottom Panel 1 PC</p>	<p>Cross Rail 2 PCS</p>	<p>Left Door Panel 1 PC</p>	<p>Right Door Panel 1 PC</p>	<p>Drawer Front Panel 3 PCS</p>
<p><b>K</b></p> 	<p><b>L</b></p> 	<p><b>M</b></p> 	<p><b>N</b></p> 	<p><b>O</b></p> 
<p>Drawer Left Panel 3 PCS</p>	<p>Drawer Right Panel 3 PCS</p>	<p>Drawer Back Panel 3 PCS</p>	<p>Drawer Bottom Panel 3 PCS</p>	<p>Side Back Panel 2 PCS</p>
<p><b>P</b></p> 	<p><b>Q</b></p> 	<p><b>R</b></p> 	<p><b>S</b></p> 	
<p>Middle Back Panel 1 PC</p>	<p>Adjustable Shelf 2 PCS</p>	<p>Side Frame 2 PCS</p>	<p>Rail 2 PCS</p>	

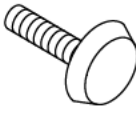
# HARDWARE LIST

<b>#1</b>  Ø8*30mm	<b>#2</b> 	<b>#3</b> 	<b>#4</b>  3/4**Ø5/32"	<b>#5</b> 
Wood Dowel 36 PCS (Extra 1)	Handle 2 PCS	Knob 3 PCS	Round Head Bolt 7 PCS (Extra 1)	Cam Bolt 24 PCS
<b>#6</b> 	<b>#7</b> 	<b>#8</b> 	<b>#9</b>  2**Ø1/4**D11mm	<b>#10</b> 
Cam Lock 24 PCS (Extra 1)	Magnet 2 PCS	Round Head Screw 4 PCS (Extra 1)	Bolt 18 PCS (Extra 1)	Barrel Nut 8 PCS
<b>#11</b> 	<b>#12</b> 	<b>#13</b> 	<b>#14</b> 	<b>#15</b> 
Allen Wrench 1 PC	Shelf Holder 8 PCS	Screw 30 PCS (Extra 1)	Adjustable Leveler 4 PCS	Safety Strap Kit 1 SET

## ADDITIONAL TOOLS (Not Provided)

Note: It is not recommended to use power tools during assembly.

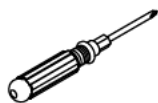

Phillips Head Screwdriver

Note: Wood dowels are intended for alignment. Additional clearance between wood dowel and pre-drilled hole is intentional for ease of assembly.

Step 1. Attach cam bolts (part #5) to top panel (part A), partition panels (parts D & E) and drawer panels (parts J, K & L) using phillips head screwdriver.

NOTE: Do not overtighten cam bolts. Stop tightening once threads on cam bolt are no longer visible.

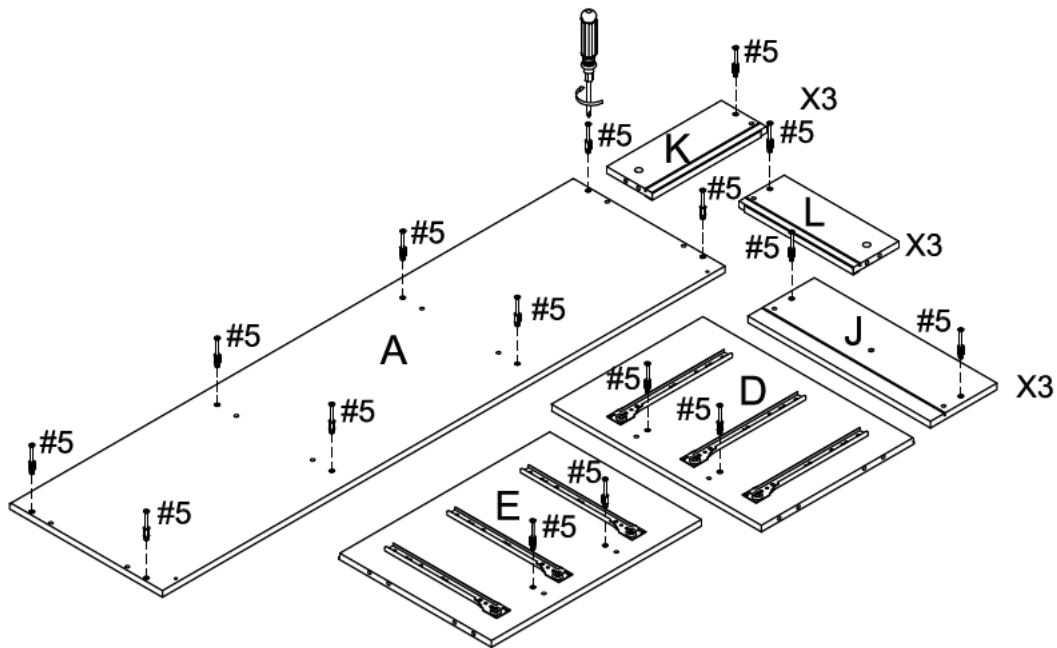

#5  x 24

Step 2. Attach handles (part #2) to door panels (parts H & I) using round head bolts (part #4) and phillips head screwdriver. Attach knob (part #3) to drawer front panel (part J) using round head bolt (part #4) and phillips head screwdriver. Attach magnets (part #7) to partition panels (parts D & E) using round head screws (part #8) and phillips head screwdriver.

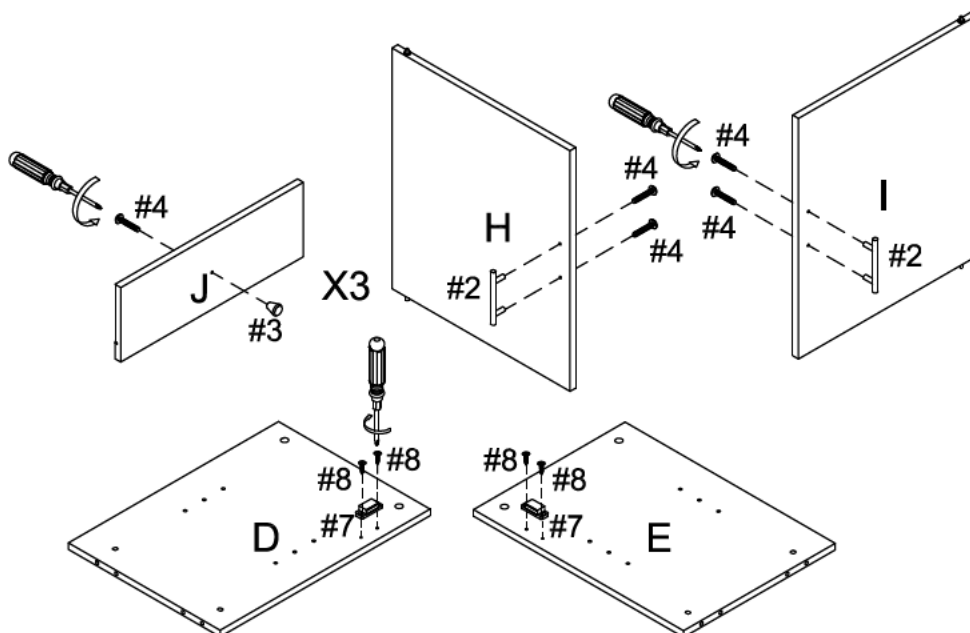

#2  x 2  
 #3  x 3  
 #4  x 7  
 #7  x 2  
 #8  x 4

Step 3. Attach drawer panels (parts K & L) to drawer back panel (part M) using wood dowels (part #1) and cam locks (part #6). Slide drawer bottom panel (part N) into grooves of assembled unit (parts K, L & M). Attach drawer front panel (part J) to assembled unit (parts K, L & N) using wood dowels (part #1) and cam locks (part #6). Repeat for remaining drawers.

NOTE: Cam locks must rotate a full 180°. See pictured insert.

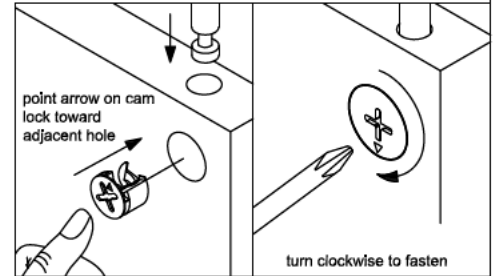
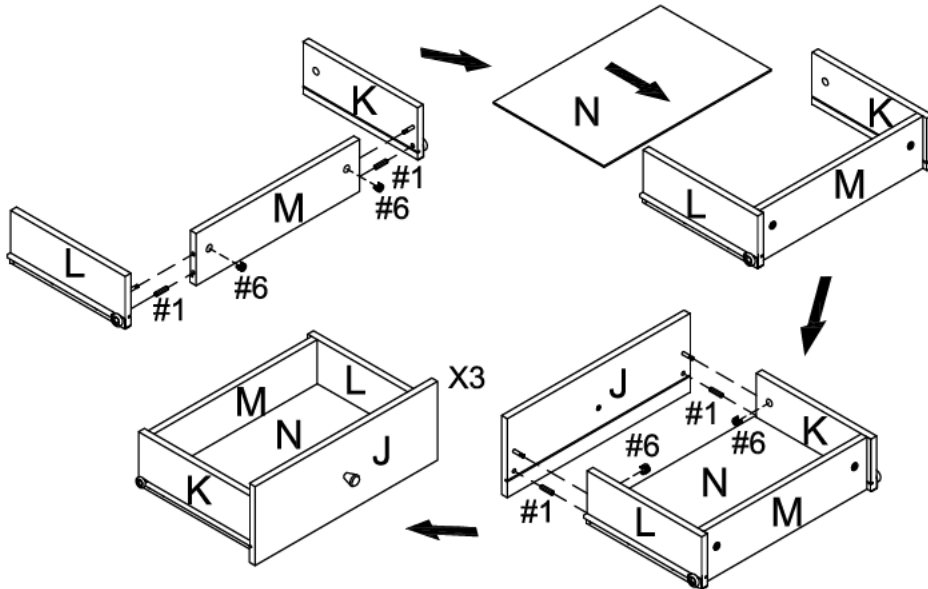

#1  x 12  
#6  x 12

Step 4. Attach cross rails (part G) to partition panels (parts D & E) using wood dowels (part #1) and cam locks (part #6).

NOTE: Cam locks must rotate a full 180°. See pictured insert.

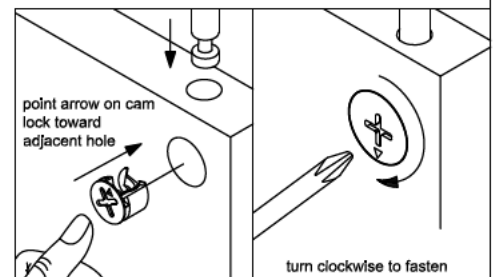
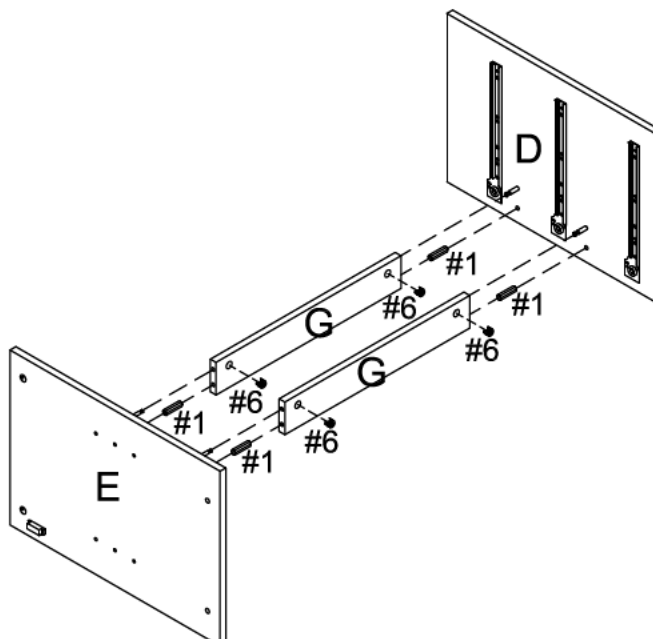

#1  x 4  
#6  x 4

Step 5. Attach bottom panel (part F) to assembled unit (parts D, E & G) using wood dowels (part #1), bolts (part #9), barrel nuts (part #10) and allen wrench (part #11).

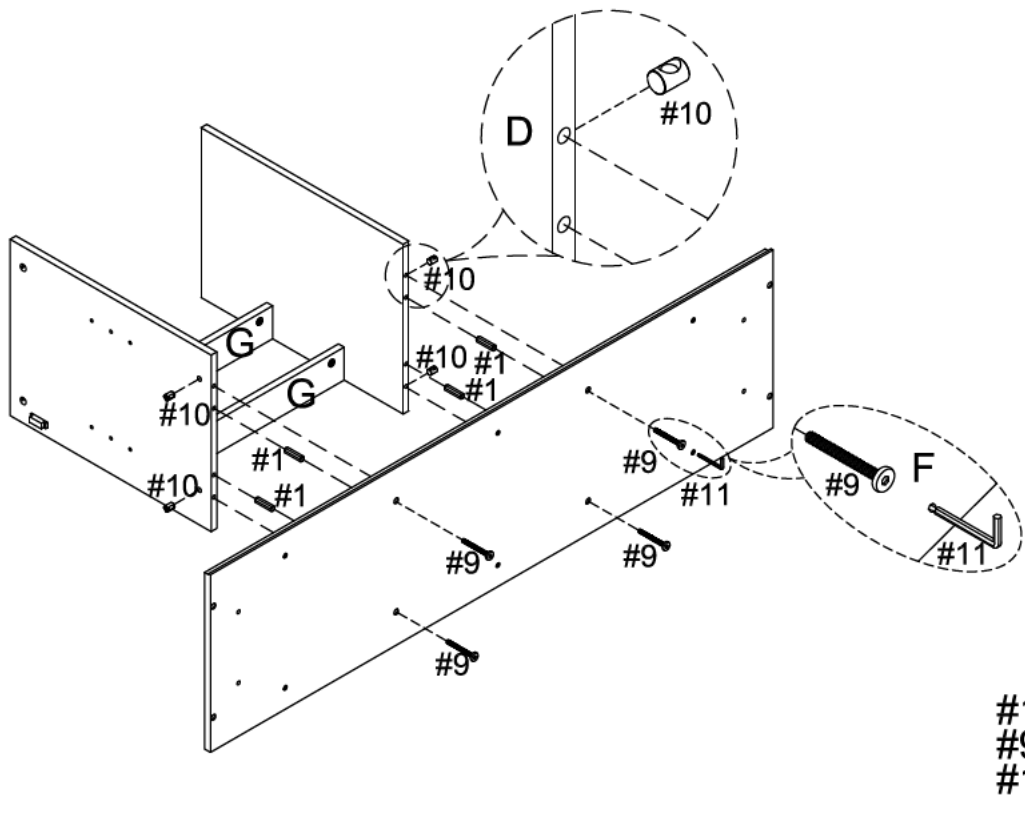

Step 6. Attach panels (parts B & C) to bottom panel (part F) using wood dowels (part #1), bolts (part #9), barrel nuts (part #10) and allen wrench (part #11).

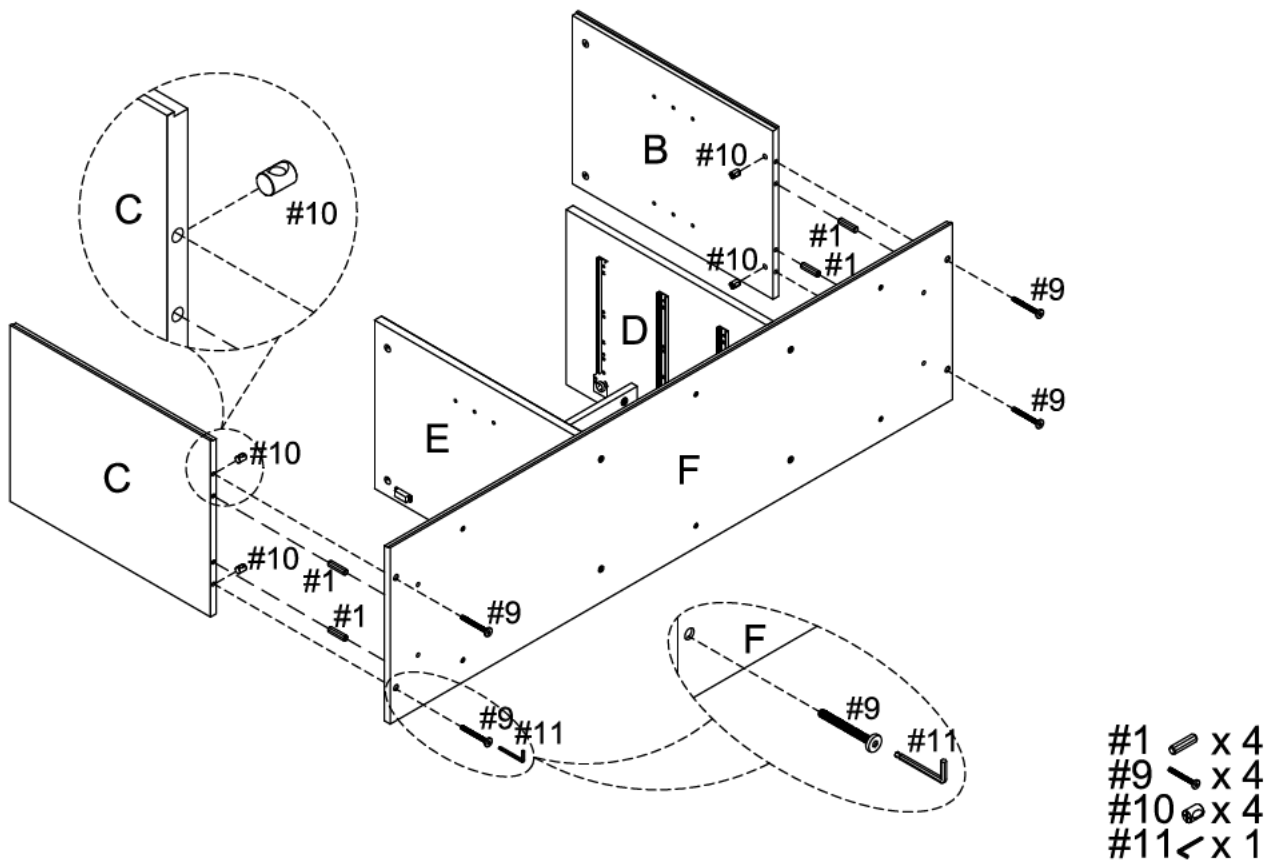

Step 7. Attach top panel (part A) to assembled unit (parts B, C, D & E) using wood dowels (part #1) and cam locks (part #6).

NOTE: Cam locks must rotate a full 180°. See pictured insert.

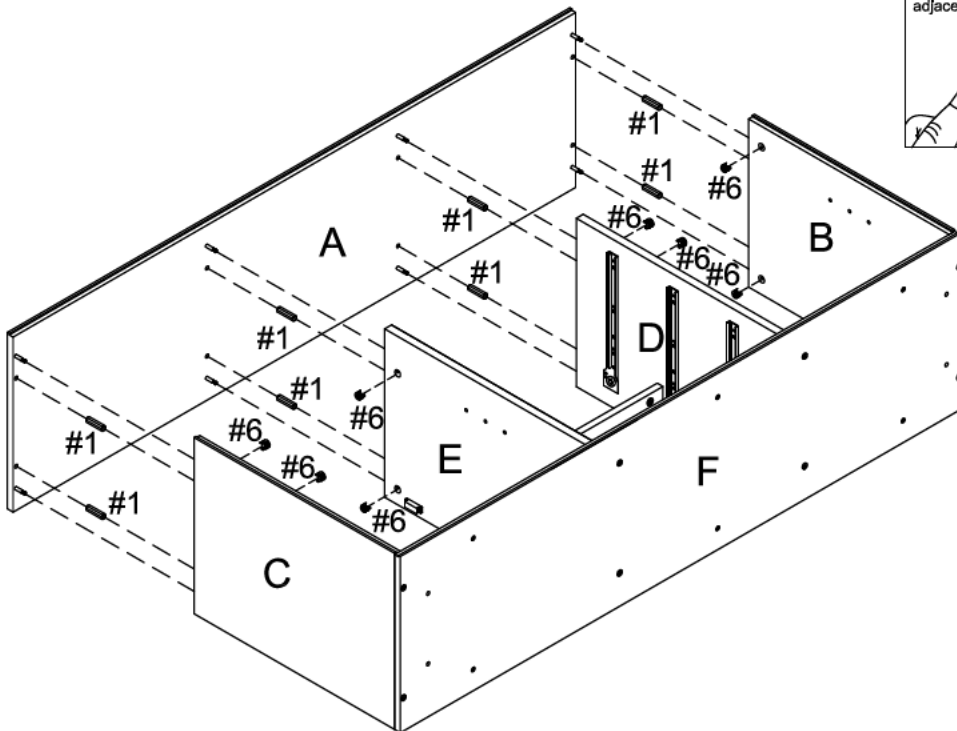
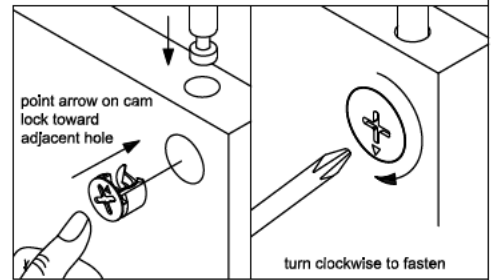

#1  x 8  
 #6  x 8

Step 8. Attach back panels (parts O & P) to assembled unit (parts A, B, C, D, E & F) using screws (part #13) and phillips head screwdriver.

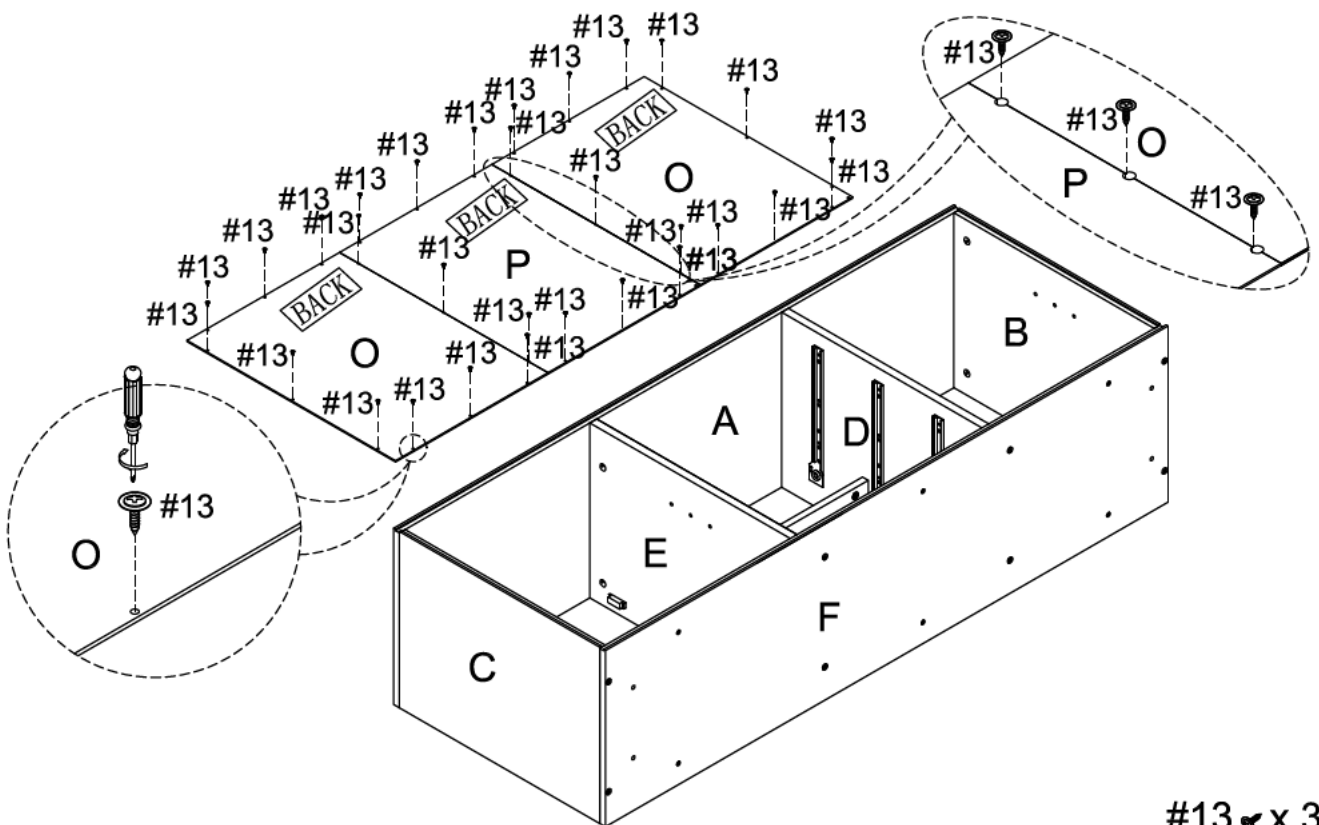

#13  x 30

Step 9. Attach rails (part S) to side frames (part R) using bolts (part #9) and allen wrench (part #11). Attach adjustable levelers (part #14) to side frames (part R).

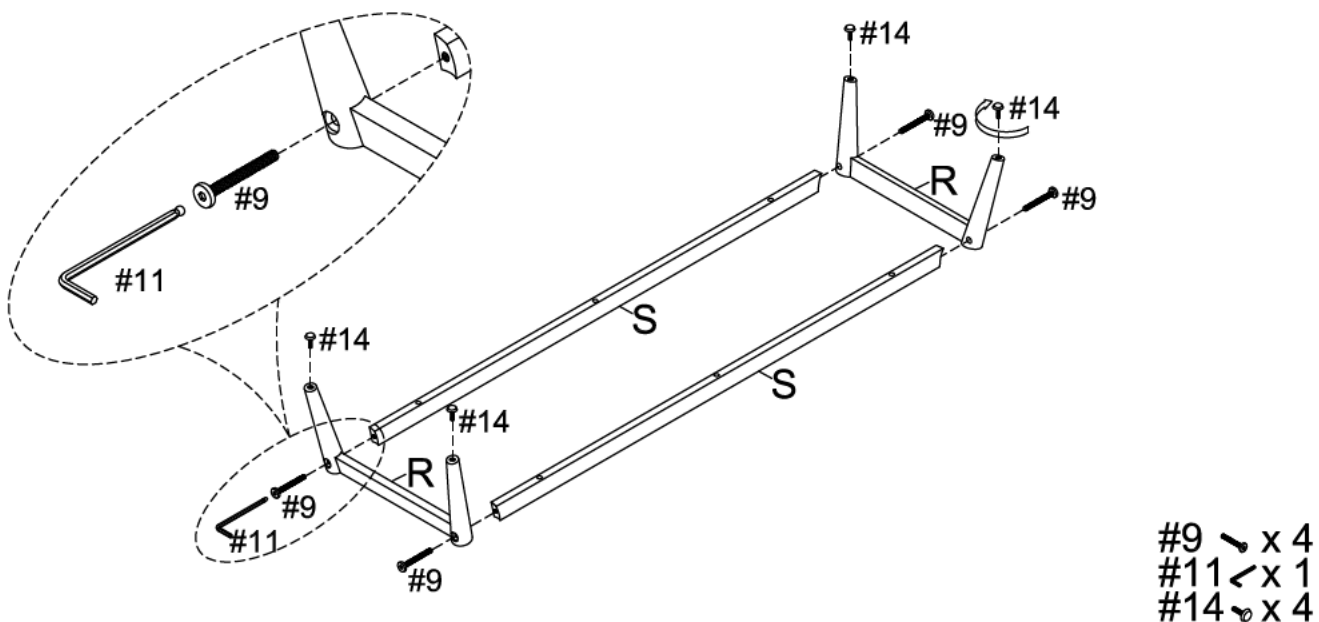

Step 10. Attach assembled unit (parts R & S) to bottom panel (part F) using wood dowels (part #1), bolts (part #9) and allen wrench (part #11).

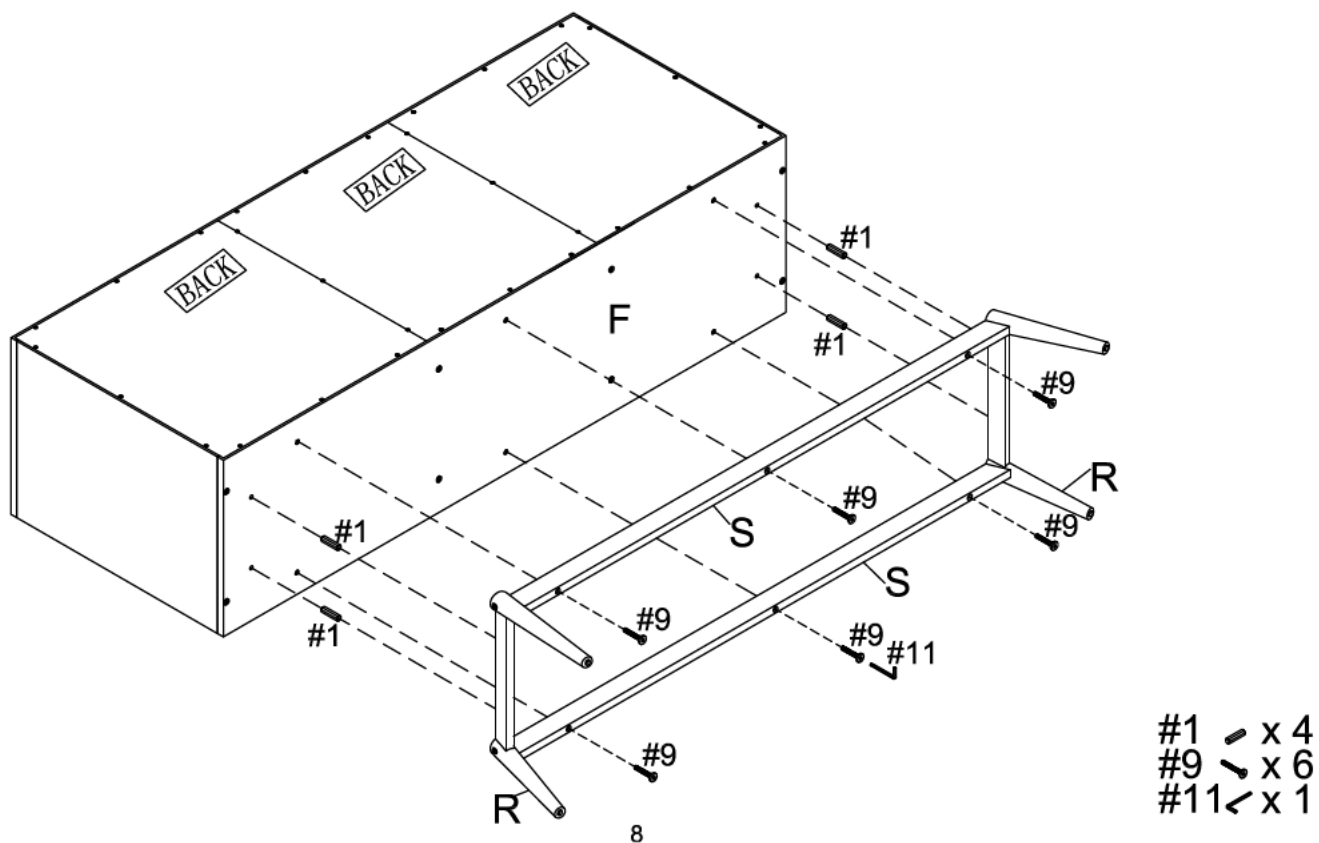

Step 11. Carefully turn unit upright. Place shelf holders (part #12) into desired position and then slide adjustable shelves (part Q) into place. Slide assembled drawers into place.

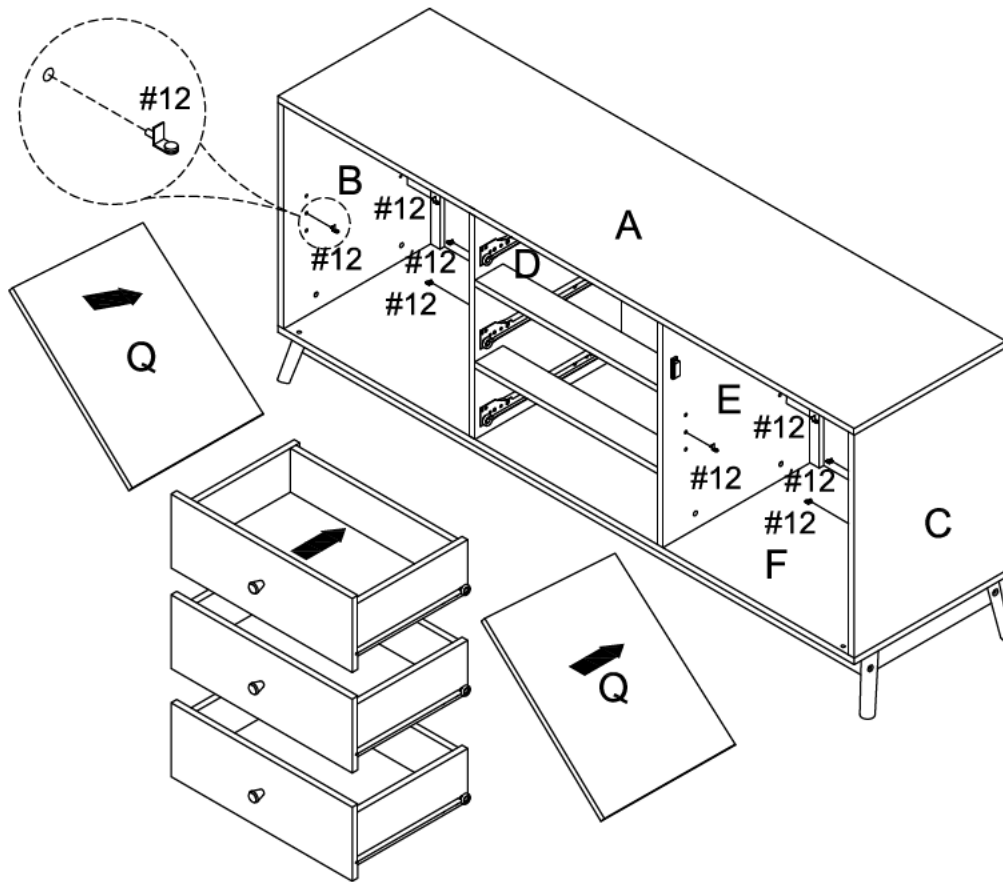

#12  $\times$  8





**Step 12. Attach door panels (parts H & I) by placing bottom pin hinge (pre-installed in door) in the pre-drilled hole of bottom panel (part F). Then depress the top spring-loaded pin hinge so it can be placed in the pre-drilled hole of top panel (part A).**

**NOTE:** Be sure top and bottom pin hinges are fully extended to secure doors in place.

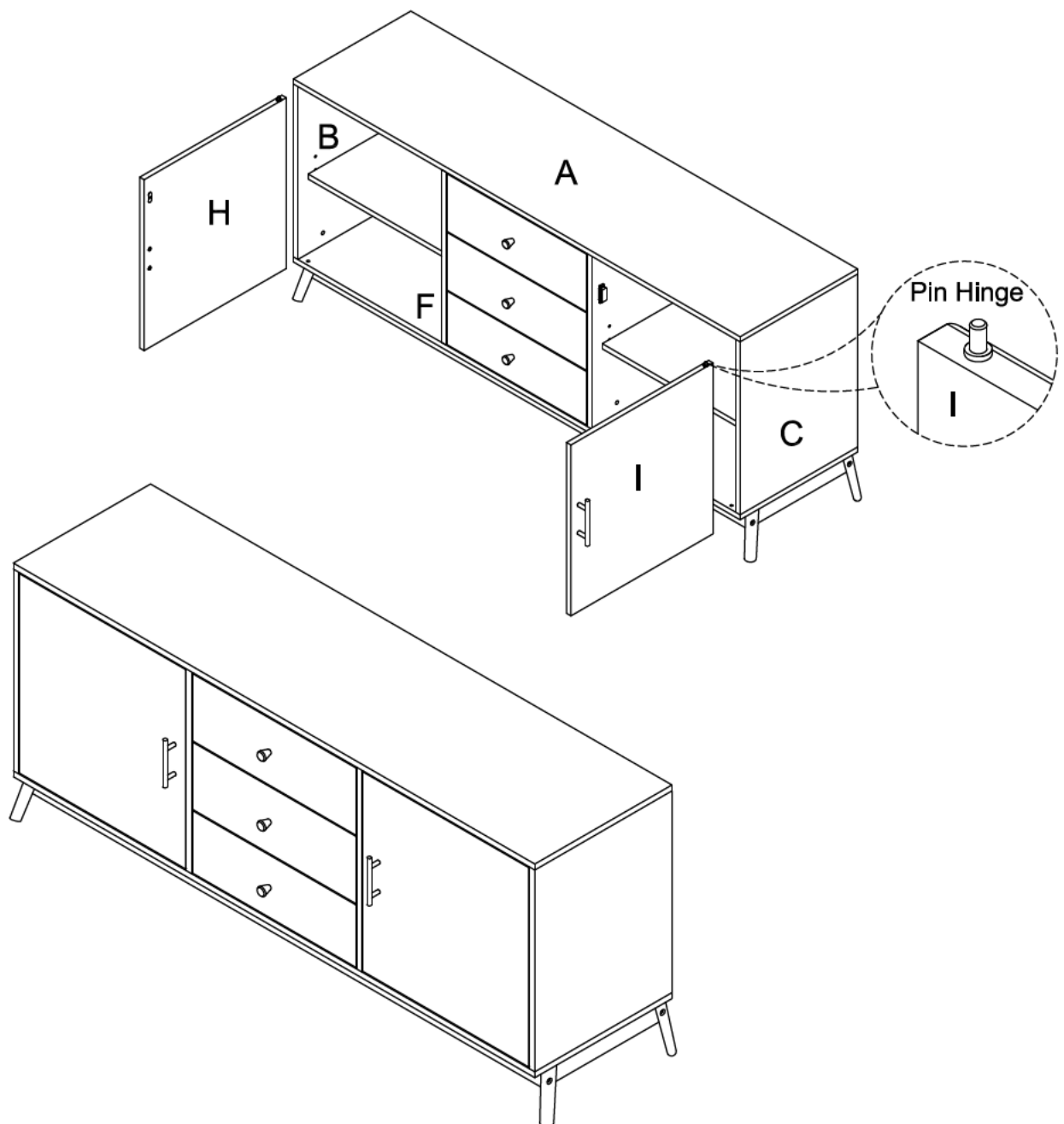
**NOTE:** It is important to adjust levelers once fully assembled and upright. Extend adjustable leveler until it's firmly in contact with the floor. If relocating, adjust leveler as needed until it's firmly in contact with the floor in new location.

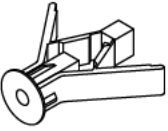
**Important:** Safety strap kit (part #15) must be installed to prevent tipping, damage and/or injury.

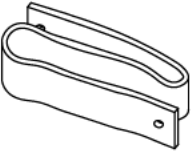

#15	A	B	C	D	E
			 D8*3/4"	 D8*1-1/2"	
Safety Strap Kit 1 SET	Wall Anchor 1 PC	Washer 2 PCS	Short Screw 1 PC	Long Screw 1 PC	Safety Wall Strap 1 PC

## SAFETY WALL STRAP INSTALLATION

Note: It is highly recommended to install this safety strap kit to prevent tipping, damage and/or injury.

1. Insert short screw (C) through washer (B) and safety wall strap (E) and attach to top panel (part A) using phillips head screwdriver.

2. Drill a 11/32" hole where you want to secure the unit. The drilled hole will be at the same height as the hole in top panel (part A) where the safety wall strap (E) is attached. Tap wall anchor (A) into the hole.

3. Insert long screw (D) through washer (B) and safety wall strap (E) into wall anchor (A) using phillips head screwdriver.

Note: This item is not intended for clothing storage use.

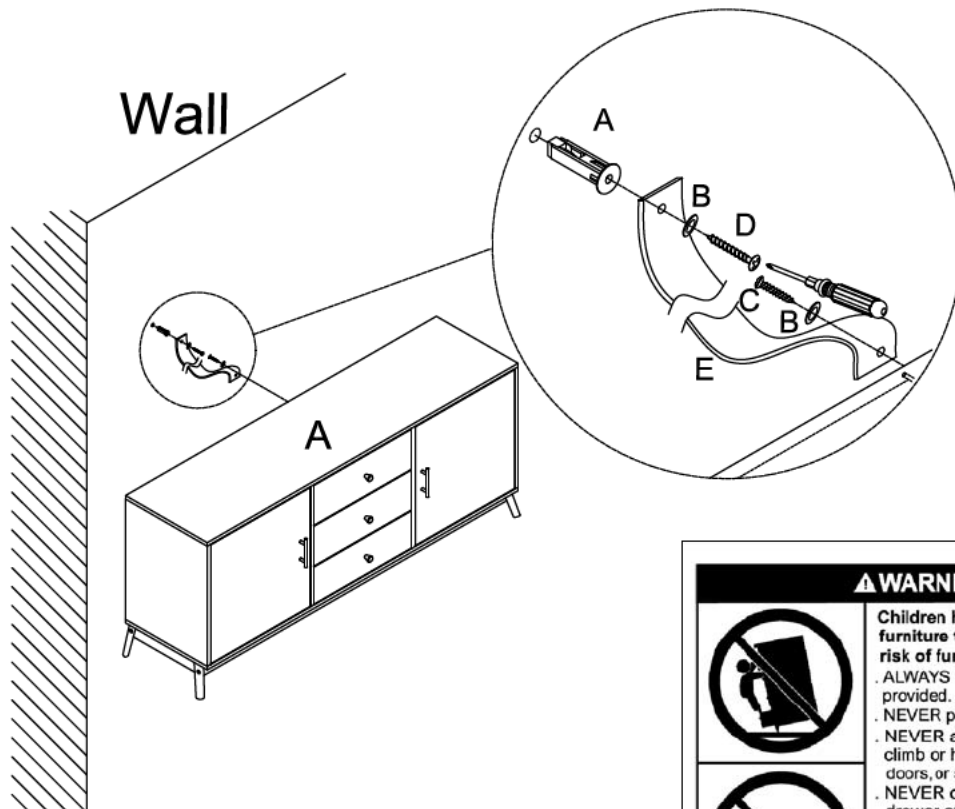

⚠ WARNING	
	<p>Children have died from furniture tipover. To reduce the risk of furniture tipover:</p> <ul style="list-style-type: none"> <li>• ALWAYS install tipover restraint provided.</li> <li>• NEVER put a TV on this product.</li> <li>• NEVER allow children to stand, climb or hang on drawers, doors, or shelves.</li> <li>• NEVER open more than one drawer at a time.</li> <li>• Place heaviest items in the lowest drawers.</li> </ul>
	<p style="text-align: center;"><i>This is a permanent label. Do not remove!</i></p>