

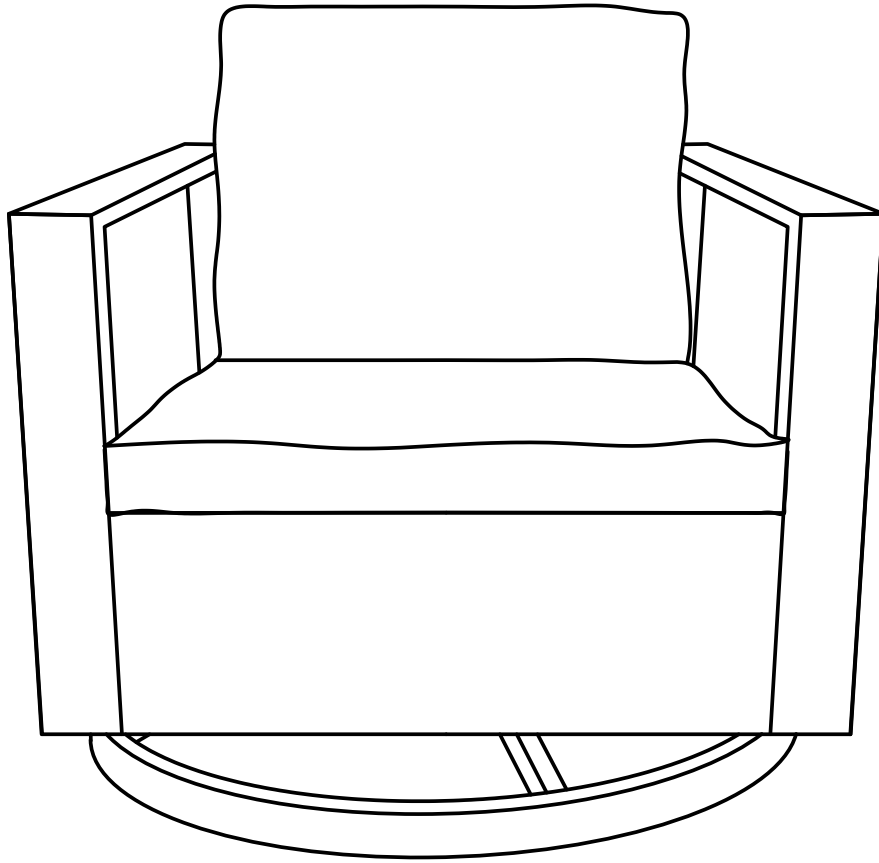









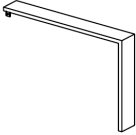

Assembly Instructions

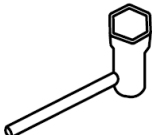
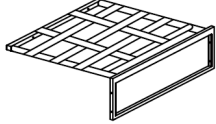

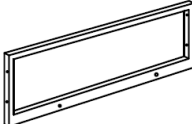
***Don't fully tighten all the bolts till the very end!**

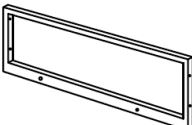

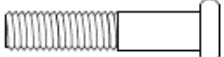
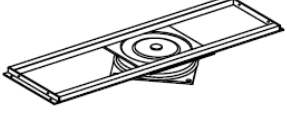
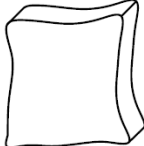
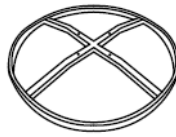
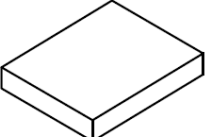
PRE-ASSEMBLY PREPARATION:

- Please read through the instructions before beginning assembly.
- Clear out the space for assembly and lay out all of the parts based on the Parts List, extra room will allow you to easily determine if all the pieces are present.
- Keep small parts and pieces away from children until fully assembled.

Part no.	Part	QTY	Image	Part no.	Part	QTY	Image
A1	Left arm	1		K	Bolt (M6*35mm)	16	
A2	Right arm	1		L	Bolt (M6*40mm)	10	
B	Back	1		M	Wrench	1	
C	Seat	1		N	Washer M6	40	
D	Right side panel	1		O	Spring washer M6	12	
E	Left side panel	1		P	Nut M6	12	
F	U-shape fitting with swing arms	2		Q	Bolt (M6*24mm)	4	
G	Swivel plate with support bar	1		R	Back cushion	1	
H	Base	1		S	Seat cushion	1	
I	Allen wrench	1					
J	Bolt (M6*20mm)	2					

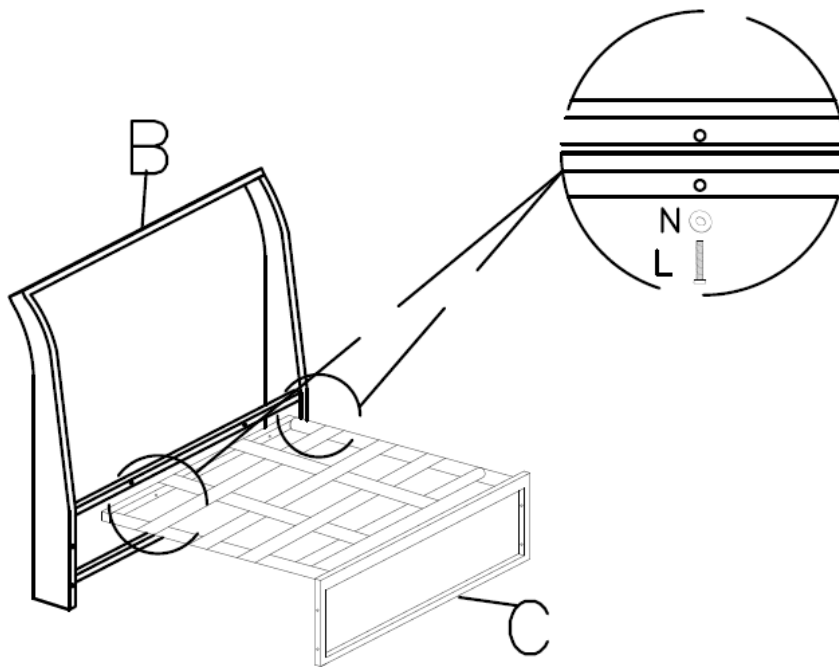

Step 1: Attach back B to seat C with 2pcs bolts L and 2pcs washers N, using Allen wrench I. Note: Don't fully tighten the bolts.



L		M6*40	2
N		M6	2

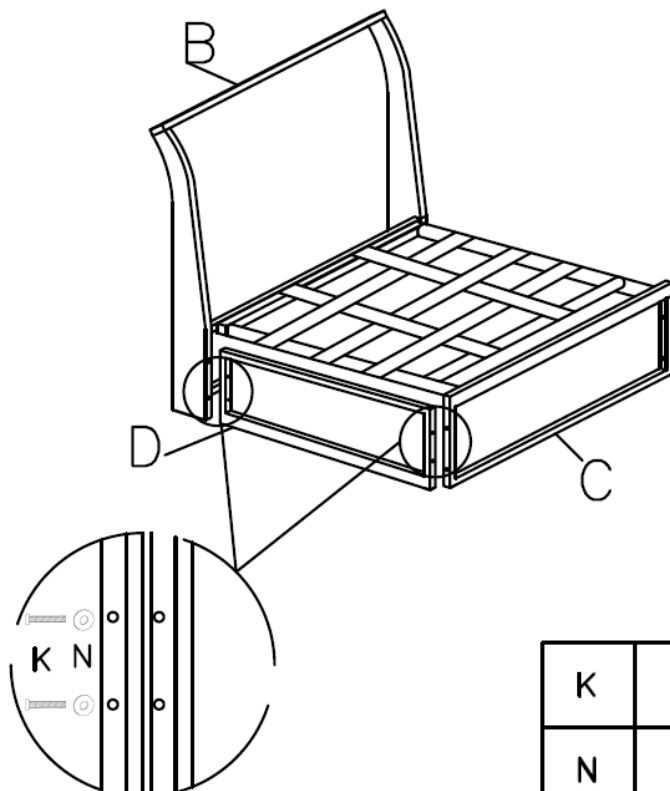

Step 2: Attach right side panel D to back B and seat C with 4pcs bolts K and 4pcs washers N, using Allen wrench I. Note: Don't fully tighten the bolts.



K		M6*35	4
N		M6	4

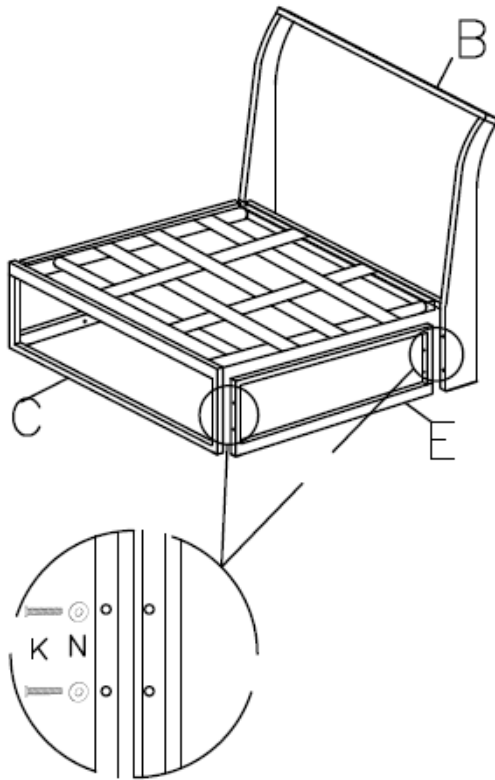

Step 3: Attach left side panel E to back B and seat C with 4pcs bolts K and 4pcs washers N, using Allen wrench I. Note: Don't fully tighten the bolts.



K		M6*35	4
N		M6	4

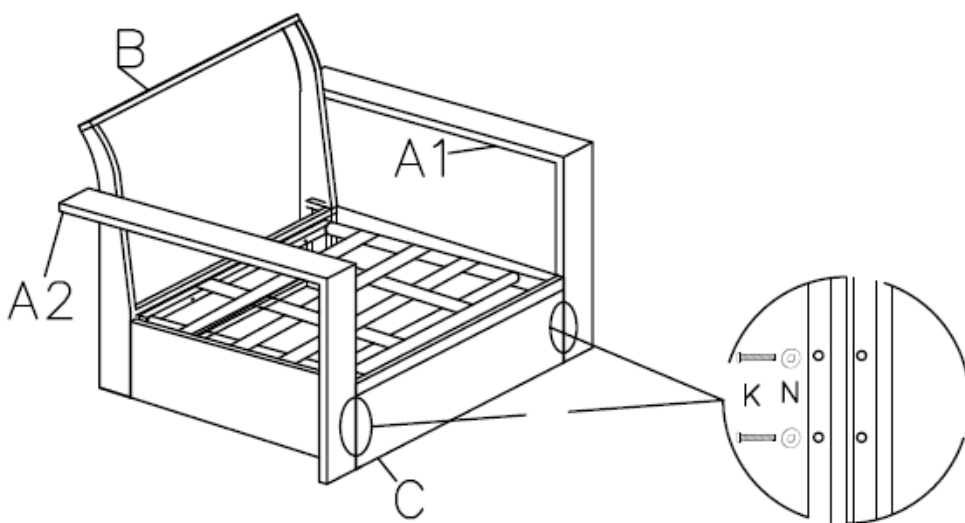

Step 4: Attach arms A1 & A2 to seat C with 4pcs bolts K and 4pcs washers N, using Allen wrench I. Note: Don't fully tighten the bolts.



K		M6*35	4
N		M6	4

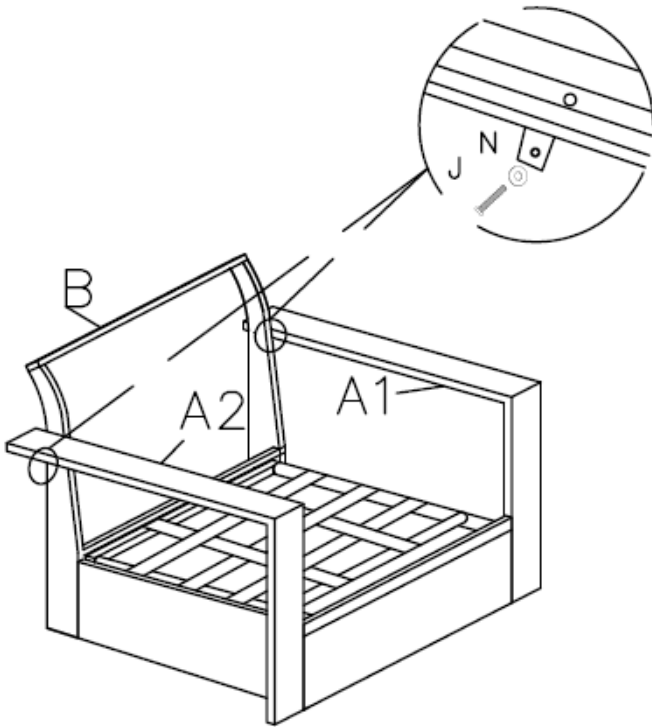



Step 5: Attach arms A1 & A2 to back B with 2pcs bolts J and 2pcs washers N, using Allen wrench I. Note: Don't fully tighten the bolts.

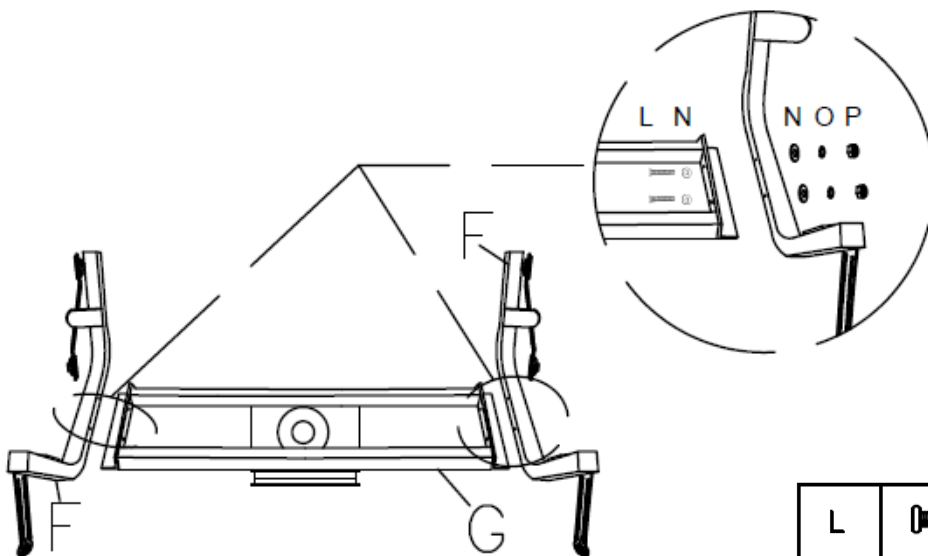

J		M6*20	2
N		M6	2





Step 6: From horizontal direction, attach 2pcs part F to part G with 4pcs bolts L, 8pcs washers N, 4pcs spring washers O, and 4pcs nuts P, using Allen wrench I and wrench M. Note: Don't fully tighten the bolts.

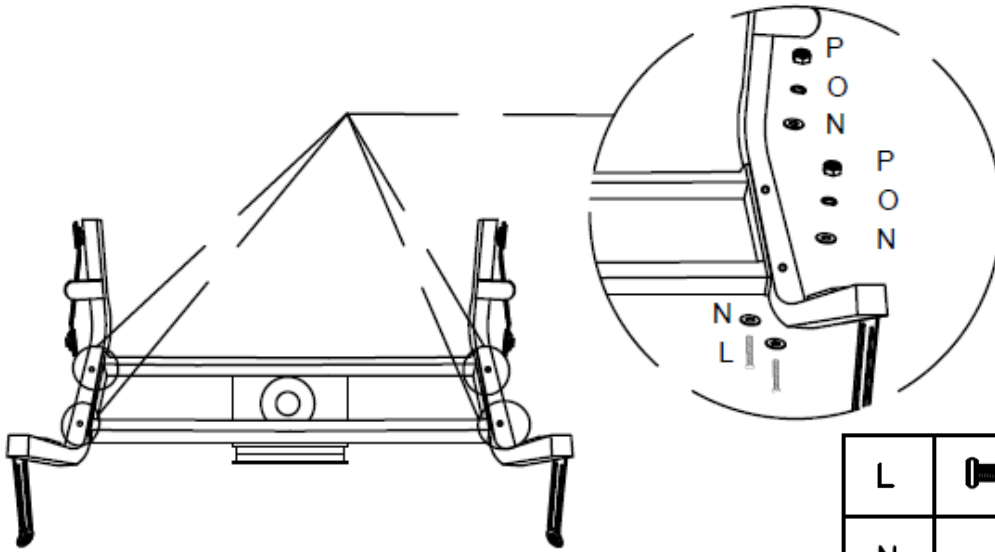

L		M6*40	4
N		M6	8
O		M6	4
P		M6	4





Step 7: From vertical direction, attach 2pcs part F to part G with 4pcs bolts L, 8pcs washers N, 4pcs spring washers O, and 4pcs nuts P, using Allen wrench I and wrench M. Note: Don't fully tighten the bolts.

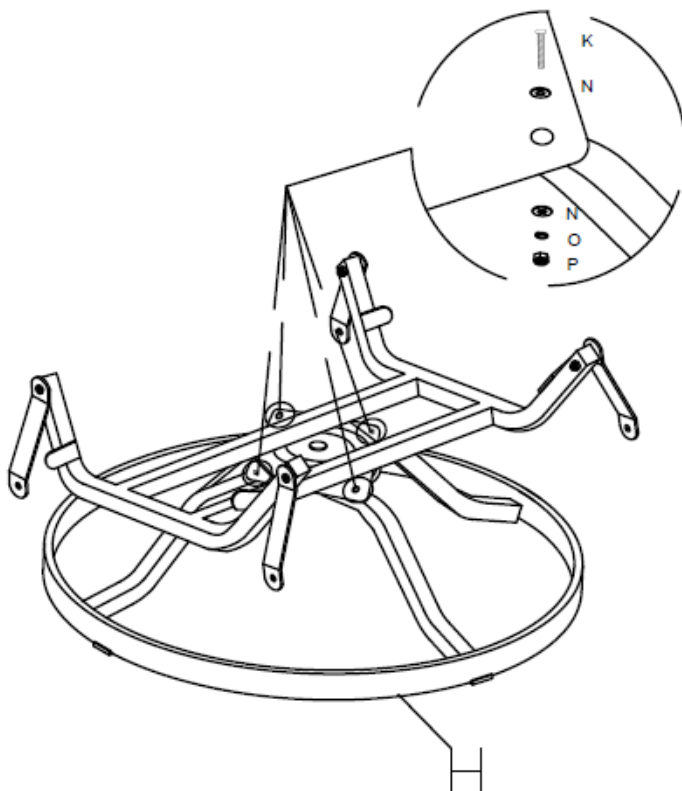

L		M6*40	4
N		M6	8
O		M6	4
P		M6	4

Step 8: Attach swivel plate to part H with 4pcs bolts K, 8pcs washers N, 4pcs spring washers O, and 4pcs nuts P, using Allen wrench I and wrench M. Note: Don't fully tighten the bolts.



K		M6*35	4
N		M6	8
O		M6	4
P		M6	4

Step 9: Attach swing arms to side panels with 4pcs bolts Q, using Allen wrench I. Note: Please fully tighten all the bolts.

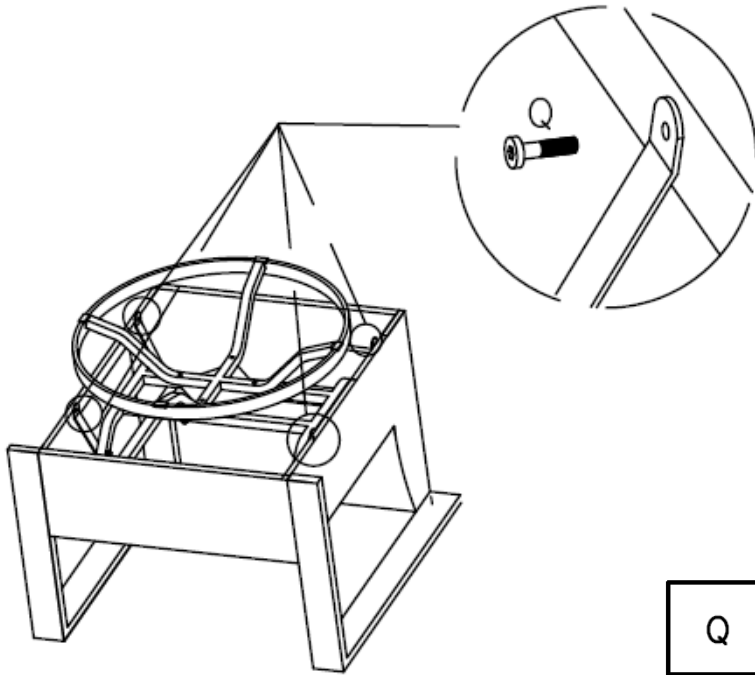

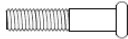
Q		ø9.5*24*M6	4
---	--	------------	---

Step 10: Put back cushion R and seat cushion S onto the seat .
Assembly is now complete and the product is ready for use.

