

SY80027 Product structure decomposition

548单 大货版本2026.1.20

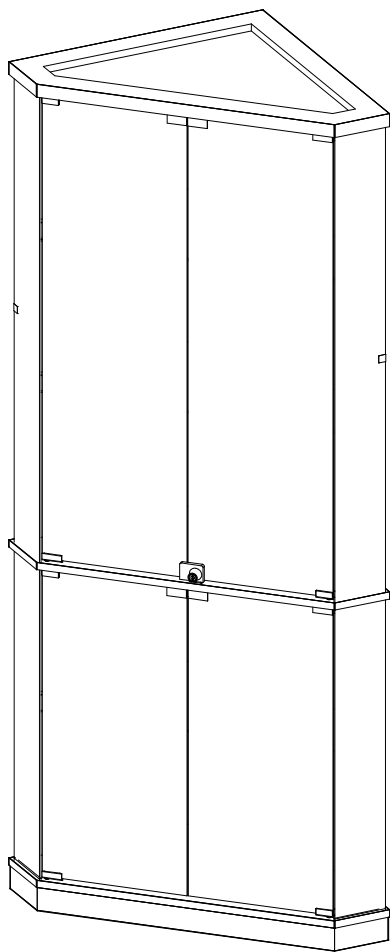

SY80027 Product structure decomposition

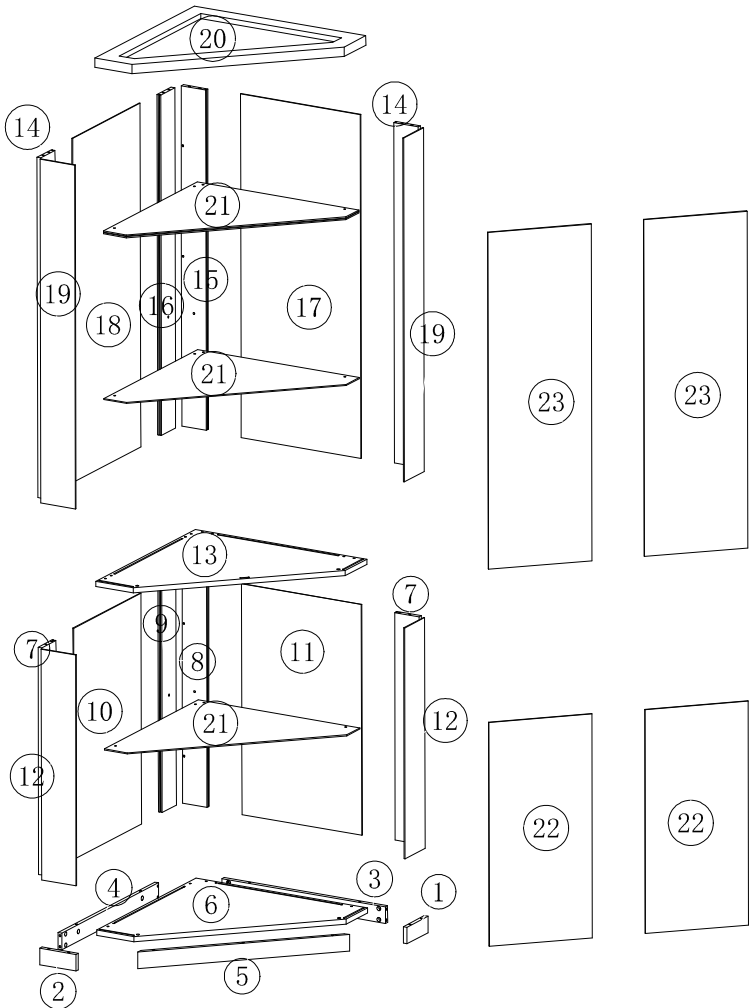

SY80027 Product structure decomposition

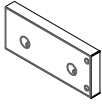

1 x 1

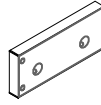

2 x 1

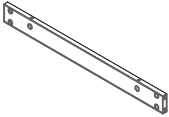

3 x 1

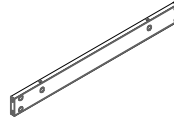

4 x 1



5 x 1

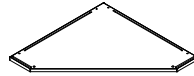

6 x 1



7 x 2



8 x 1



9 x 1



10 x 1



11 x 1



12 x 2



13 x 1



14 x 2

SY80027 Product structure decomposition



15 x 1



16 x 1



17 x 1



18 x 1



19 x 2



20 x 1

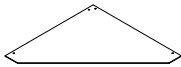

21 x 3

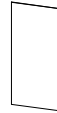



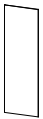





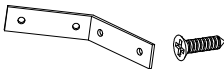

22 x 2

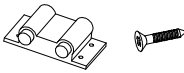

23 x 2

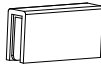
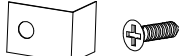
Accessories list

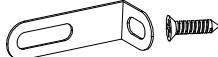
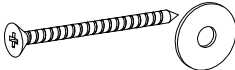
A		Two In One Screw(6x28mm)	54pcs
B		Two In One Nut(10x12mm)	54pcs
C		corner brace fastener Screw (3.5x12mm)	2-8pcs
D		Foot rubber pad	6pcs
E		corner brace fastener Screw (M4x8)	12pcs
E		Screw (M4x8)	12-12pcs
F		Lock	1pcs
G		Rebound device & Screw(3x16mm)	2-8pcs
G		hinge	4pcs
G		Iron sheet	4pcs
H		corner brace fastener Screw 3.5X10mm)	2-2pcs
K		expanded rubber tube	2pcs
K		Anti Fall Hardware Screw (3.5x14mm)	2-2pcs
K		Screw (4x45mm)	2-4pcs

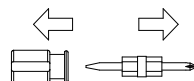
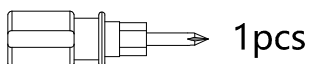

Double-head screwdriver, use as required

Locking Operation

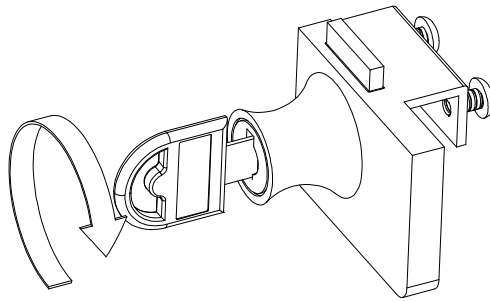

Turn the key clockwise →
The lock core extends →
Lock the door.

Unlocking Operation:

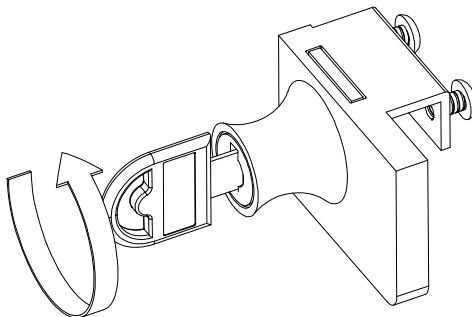

Turn the key counterclockwise →
The lock core retracts to its original position →
Open the door

Use parts ① and ②

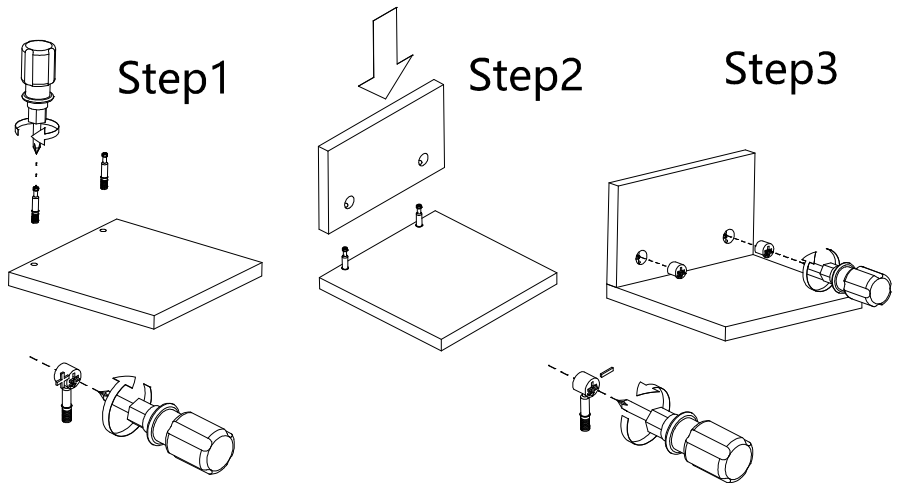

Use a screwdriver to lock in the direction of the "+" sign

Disassemble along the direction of "-" sign

Step 1

code	Diagram	count
A		4

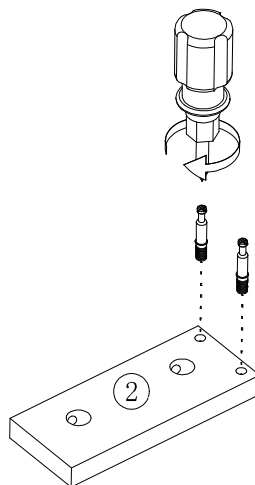
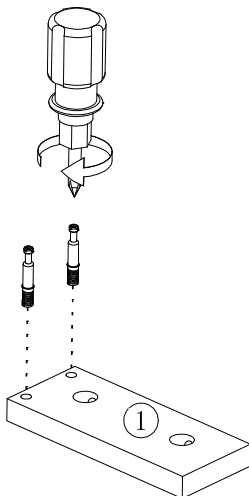

Step2

code	Diagram	count
A		2

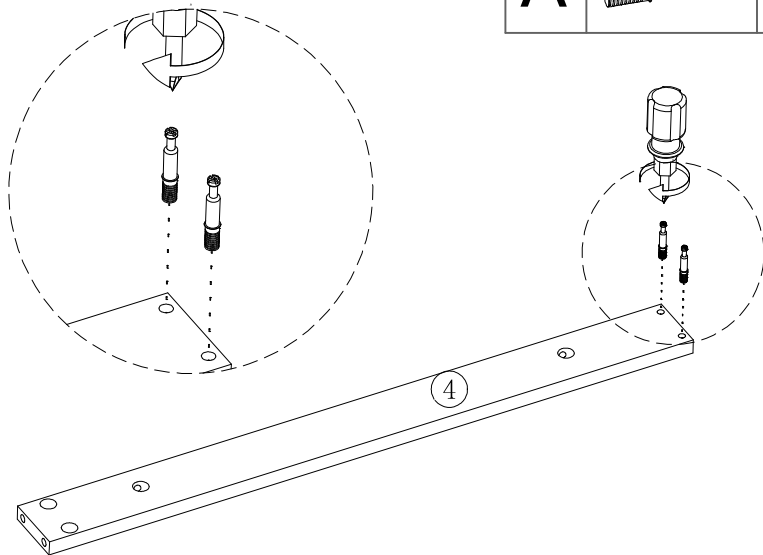

Step3

code	Diagram	count
B		2

All holes are aligned in the same direction.

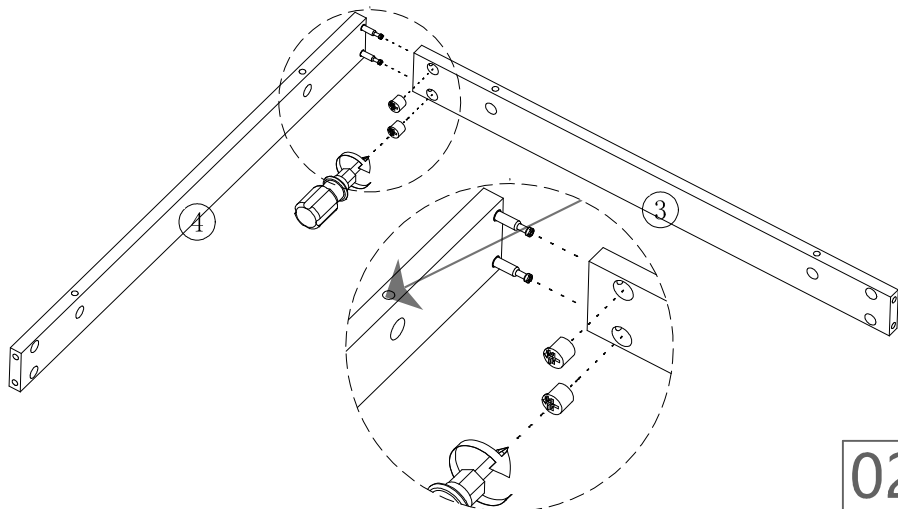

02

Step4

code	Diagram	count
B		4

All holes are aligned in the same direction.

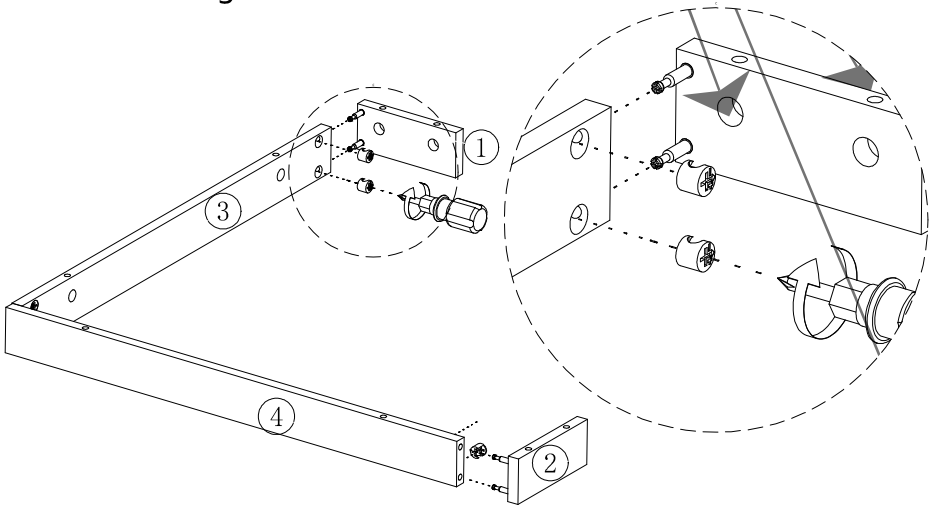

Step5

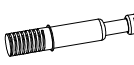
code	Diagram	count
A		11

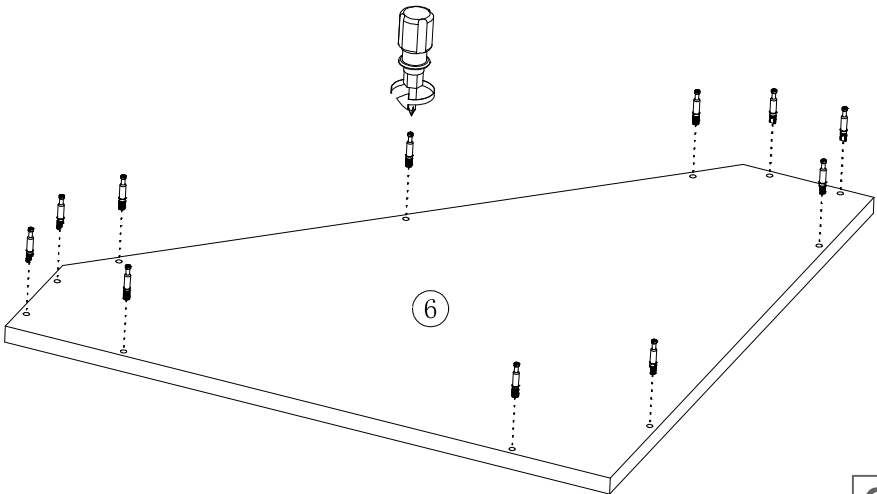

Step6

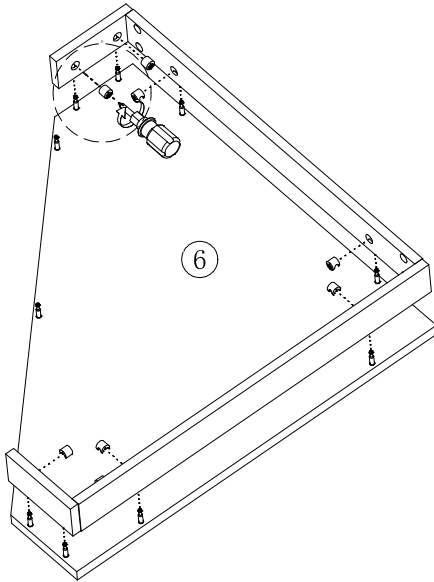

code	Diagram	count
B		8

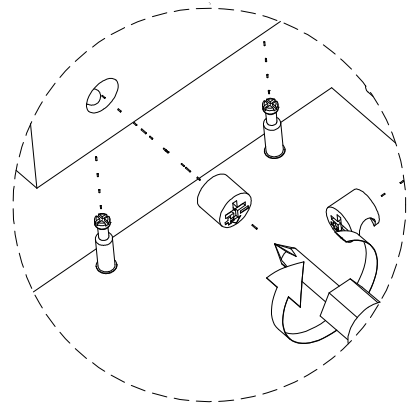

Step7

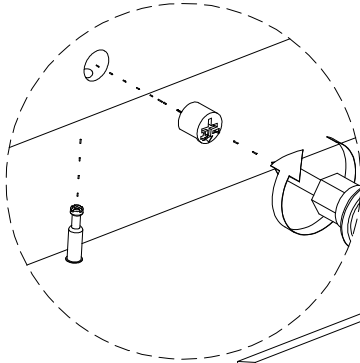

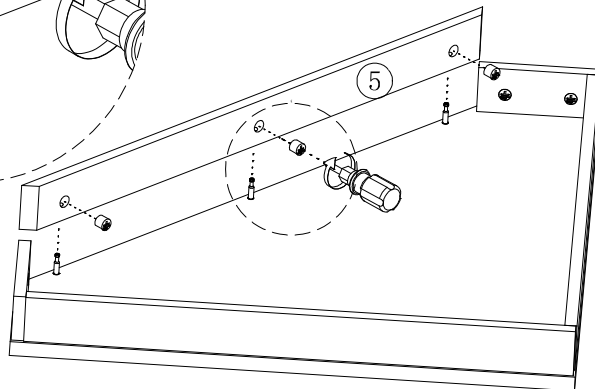

code	Diagram	count
B		3

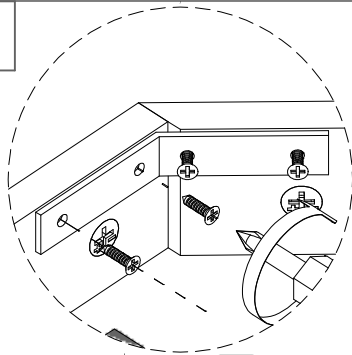

Step8

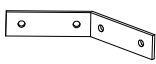

code	Diagram	count
C		2
C	 3.5X12mm	8
D		6

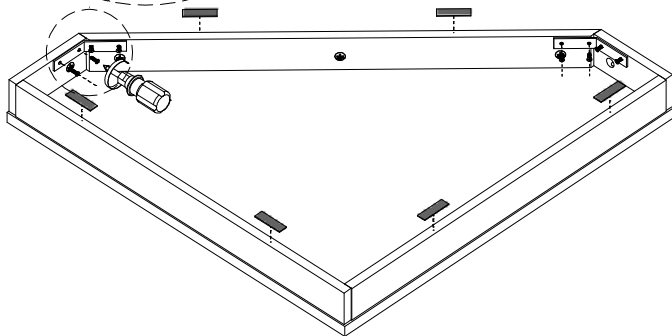

Step9

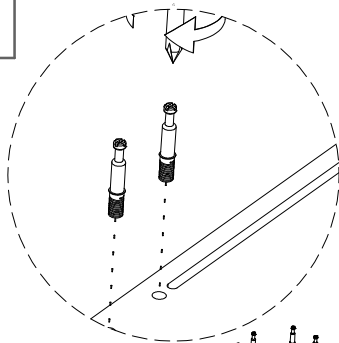

code	Diagram	count
A		8

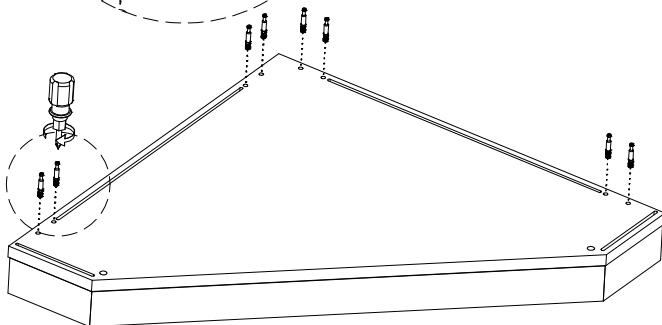

Step10

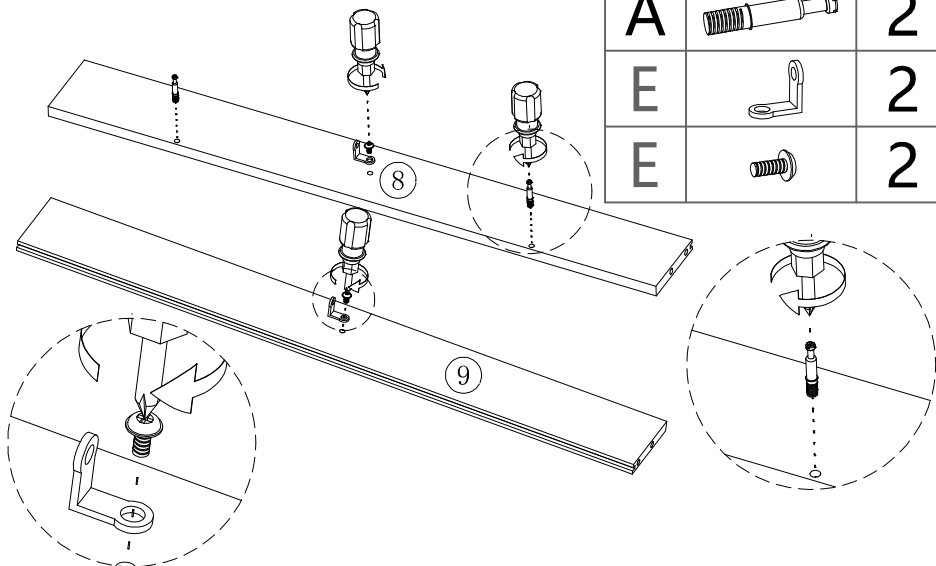

code	Diagram	count
A		2
E		2
E		2

Step11

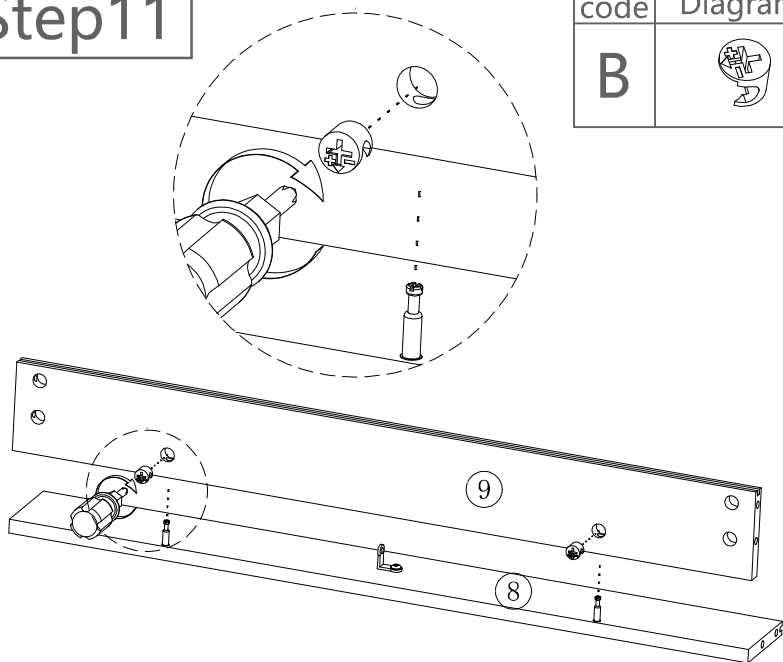

code	Diagram	count
B		2

Step12

smaller hole

bigger hole

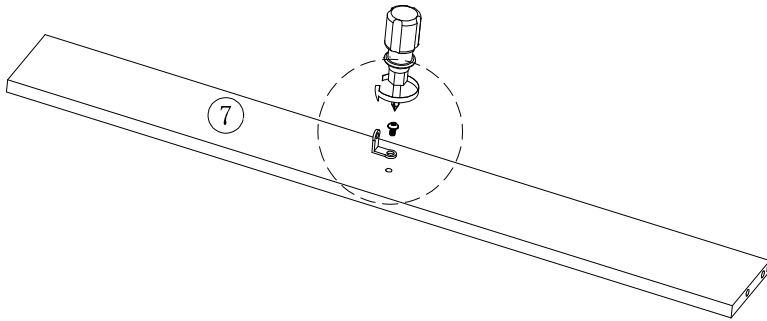

code	Diagram	count
E		1
E		1

Step13

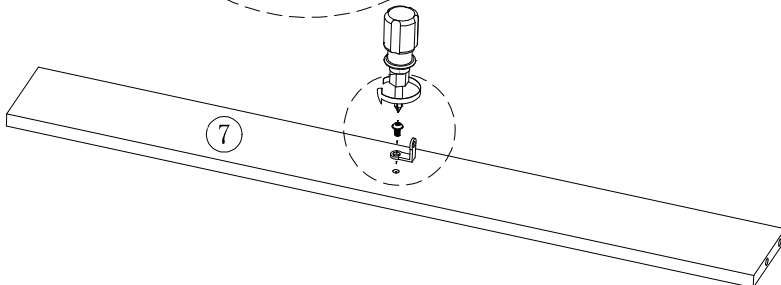
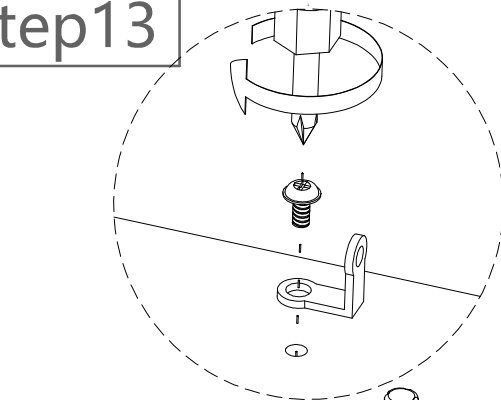

code	Diagram	count
E		1
E		1

Step14

code	Diagram	count
B		8

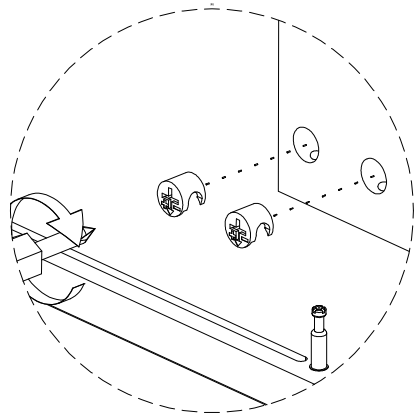
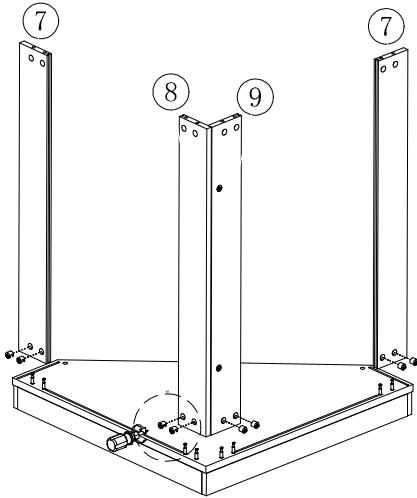

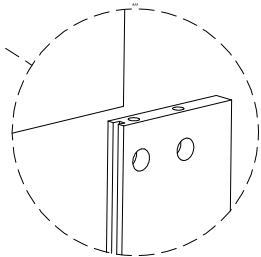
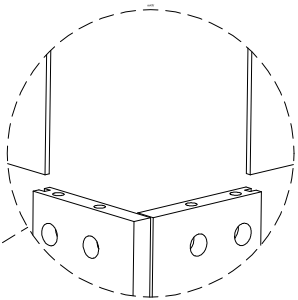
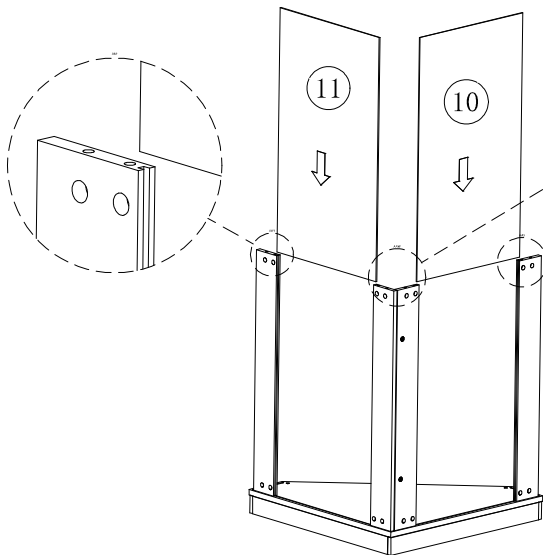

Step15

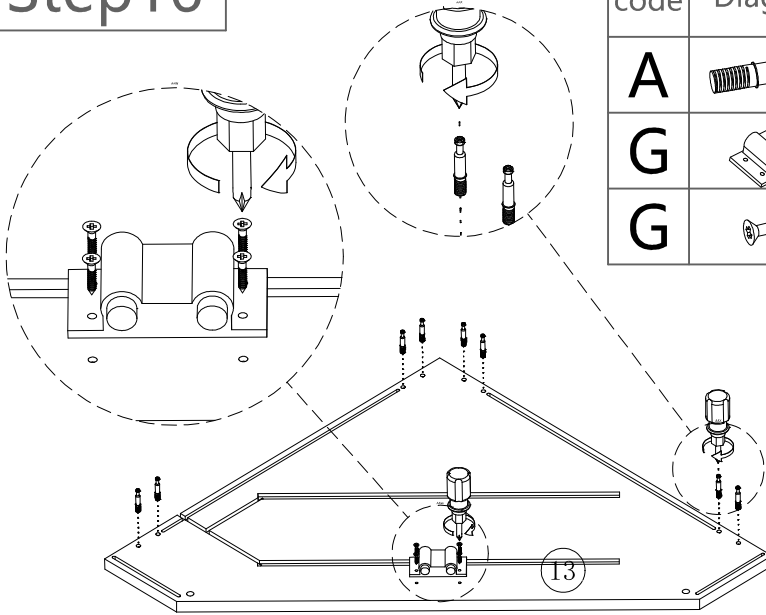

Step16

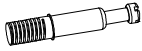
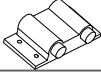

code	Diagram	count
A		8
G		1
G		4

Step17

The installation direction of the glass, as indicated by the arrow.

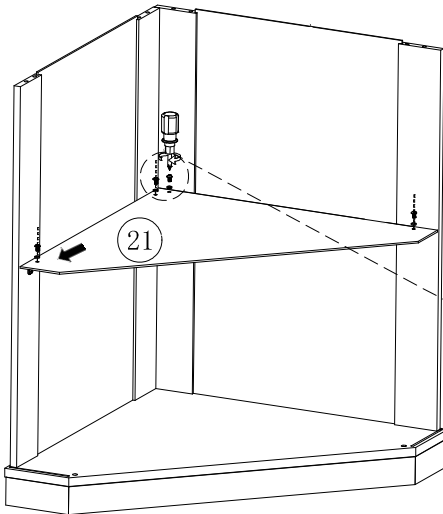

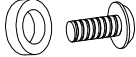
code	Diagram	count
E	 M4X8mm	4

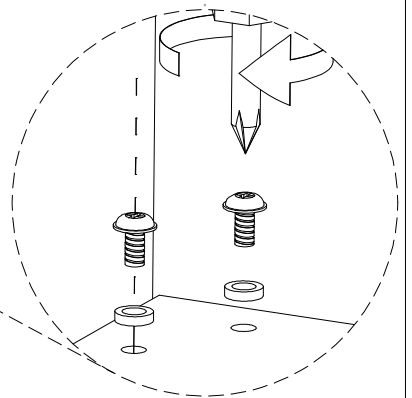

Step18

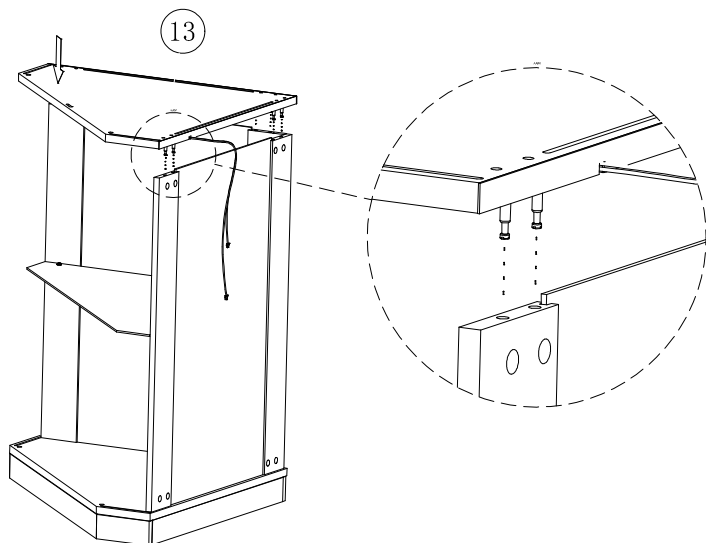

Step19

code	Diagram	count
B		1

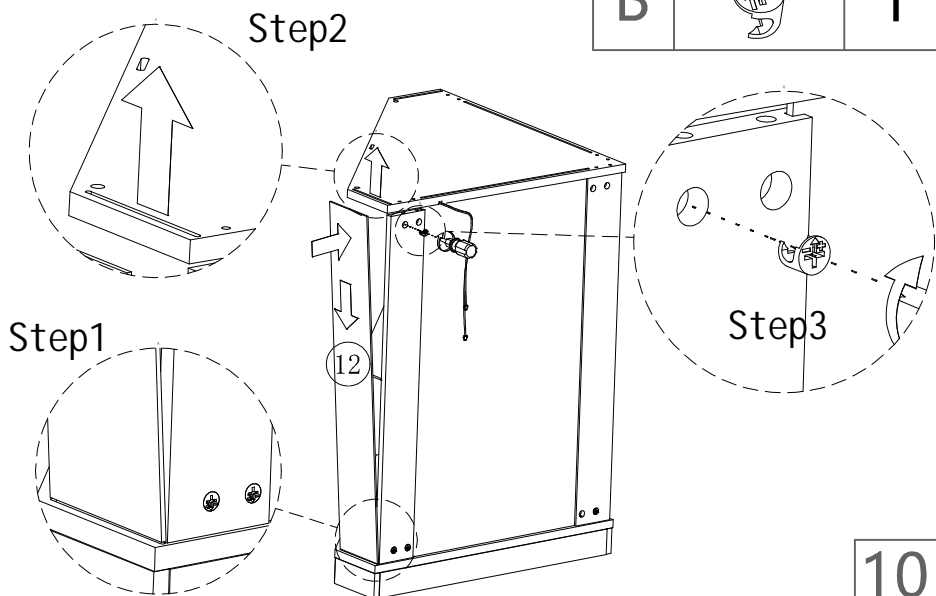

Step20

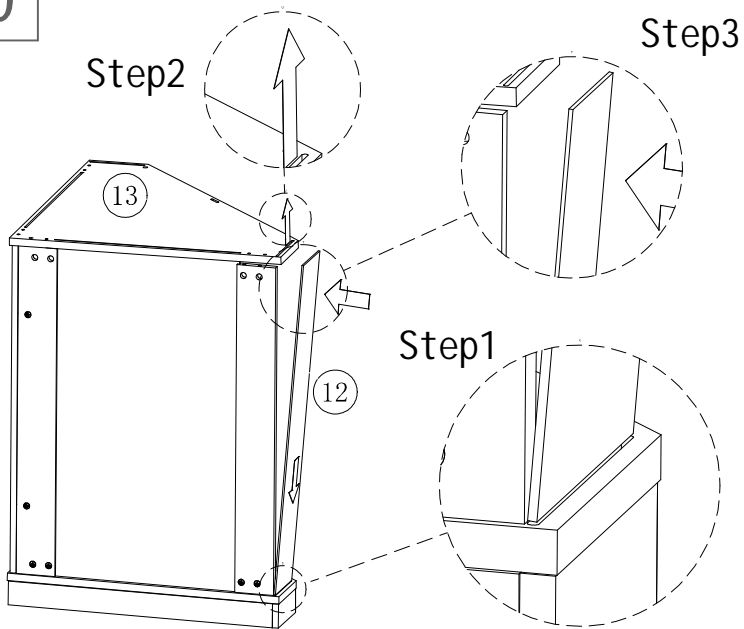

Step21

code	Diagram	count
B		7

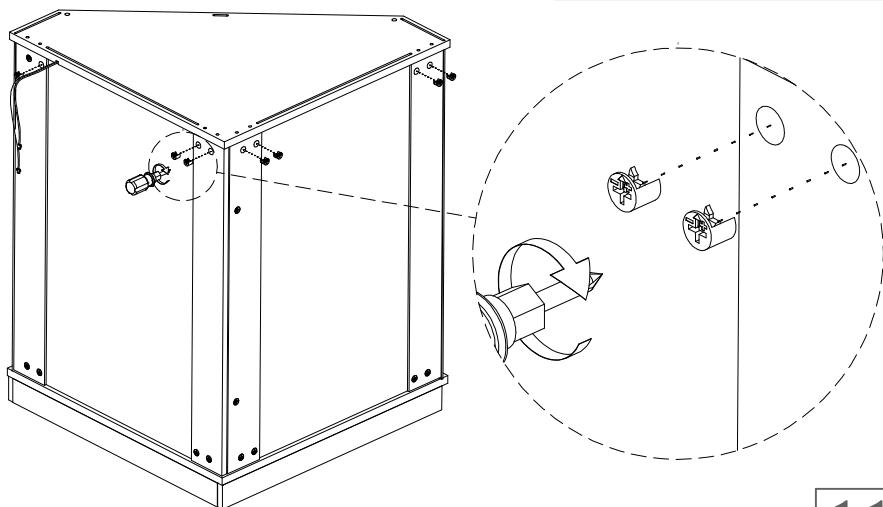

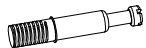

Step22

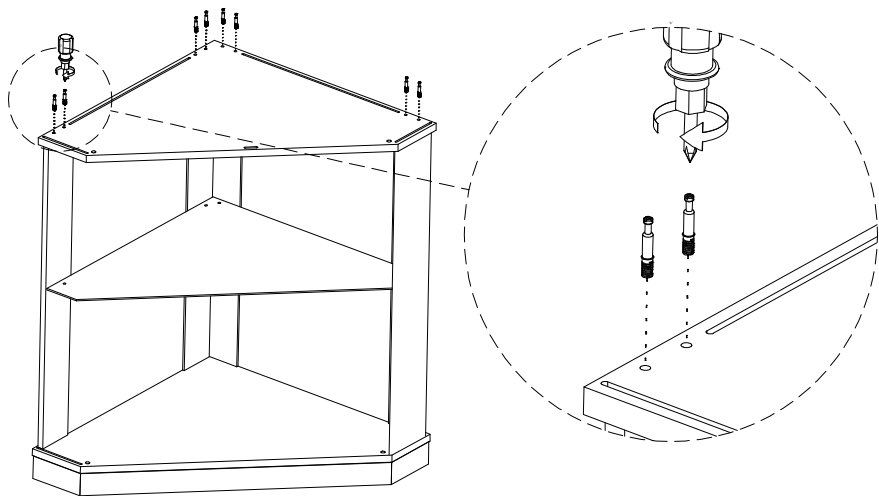
code	Diagram	count
A		8



Step23

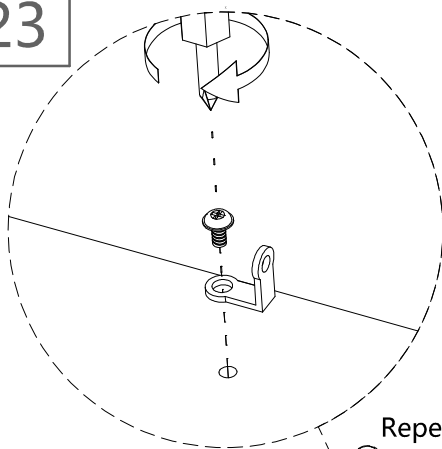

code	Diagram	count
E		2
E		2

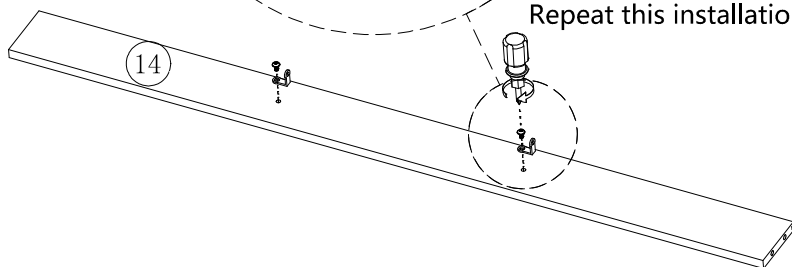

Repeat this installation step twice



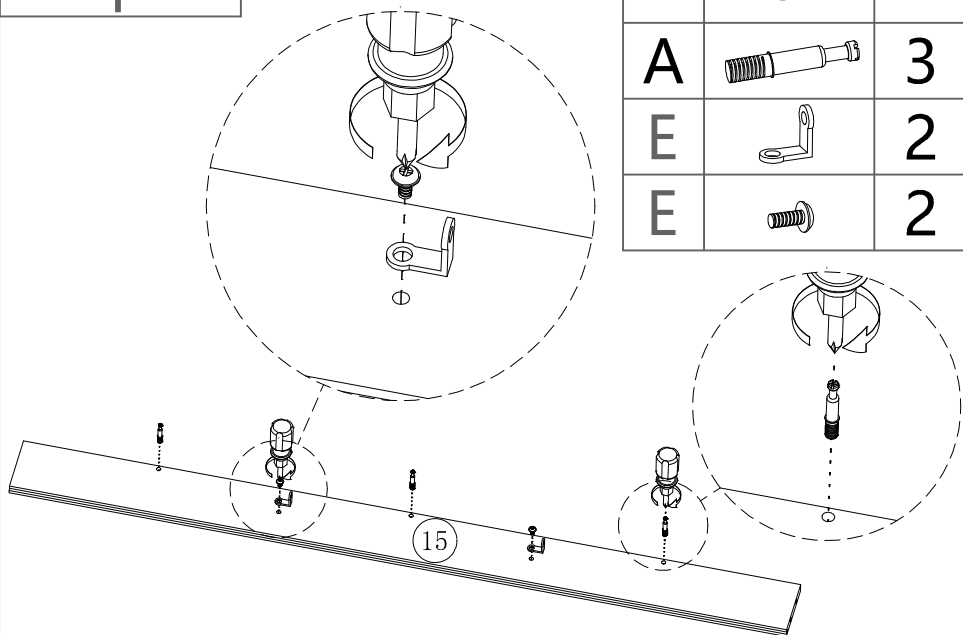

Step24

code	Diagram	count
A		3
E		2
E		2



Step25

code	Diagram	count
E		2
E		2

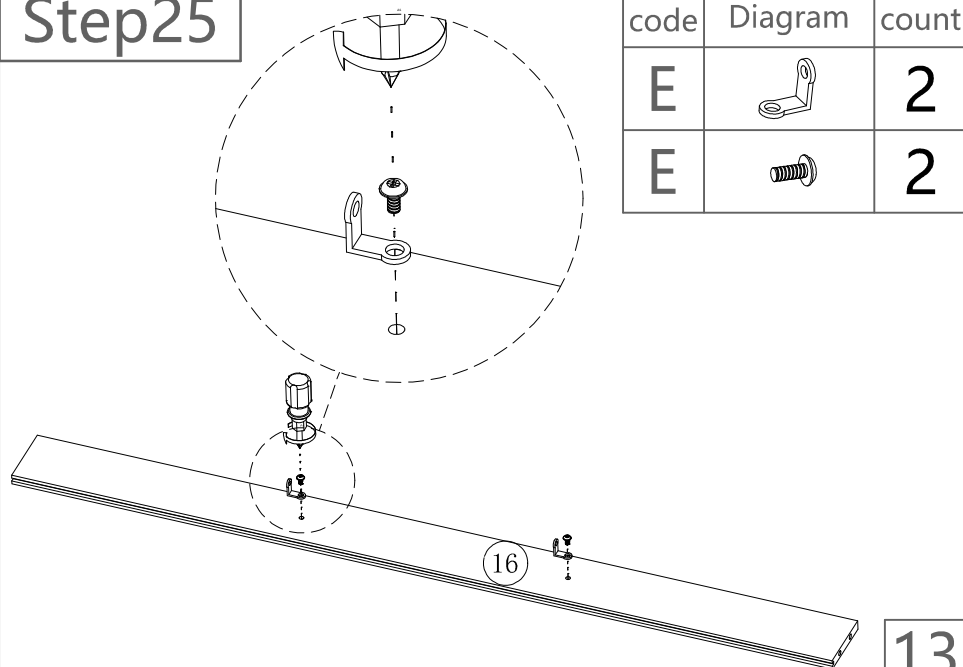

Step26

code	Diagram	count
B		3

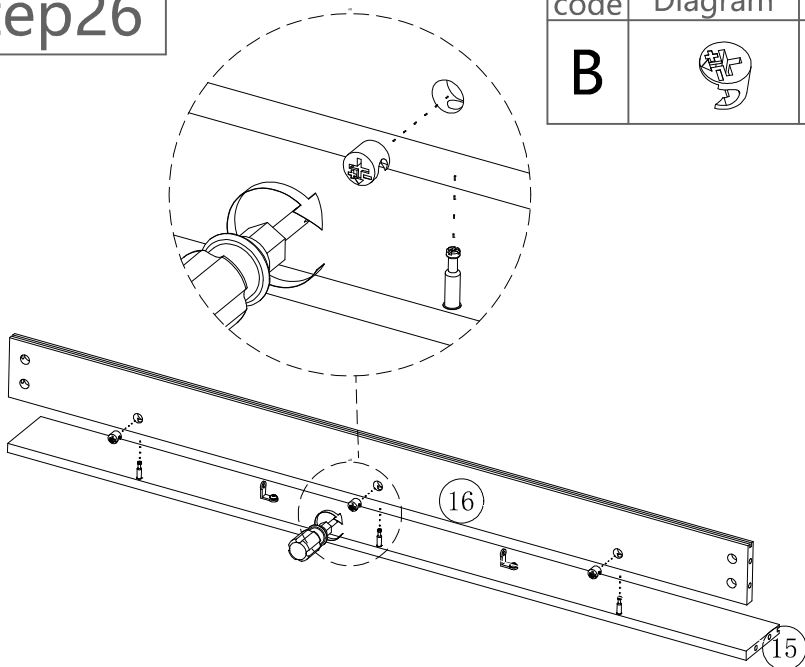

Step27

code	Diagram	count
B		8

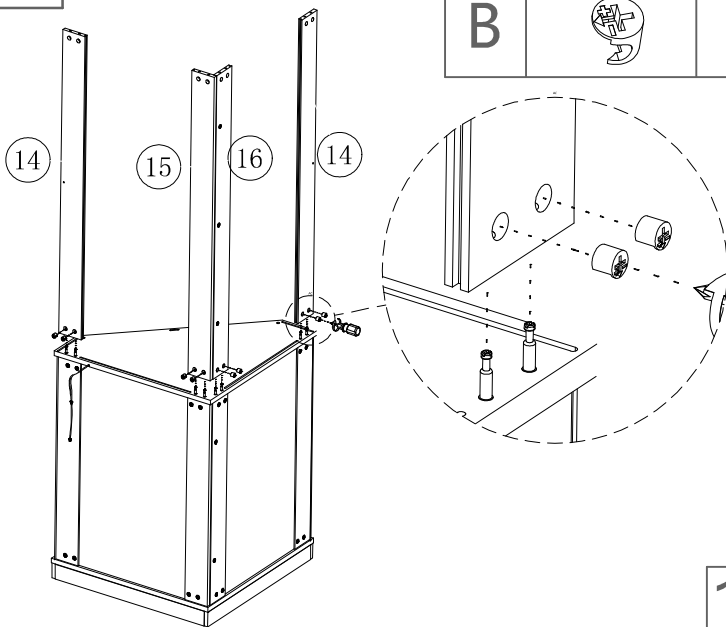

Step 28

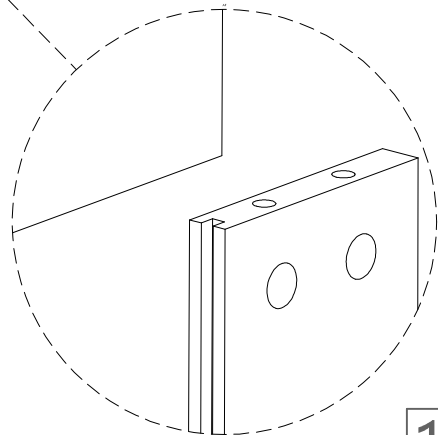
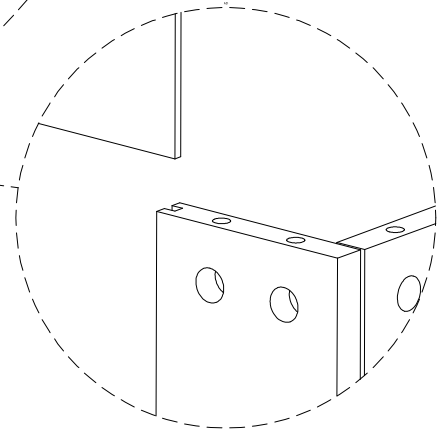
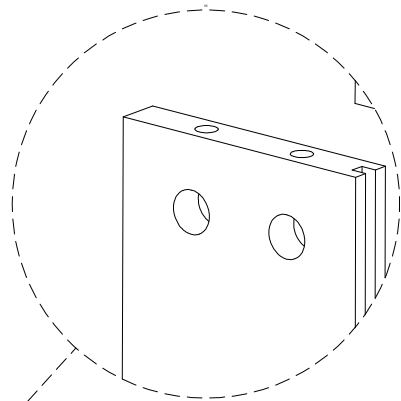
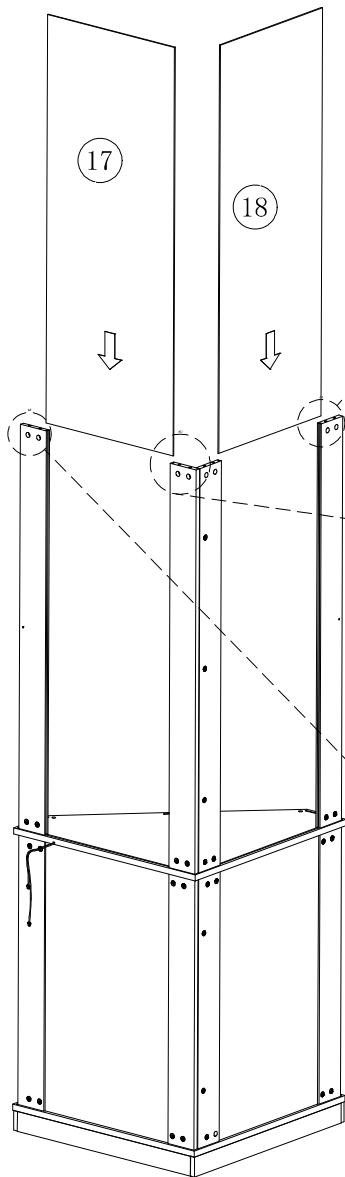

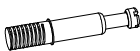

Step29

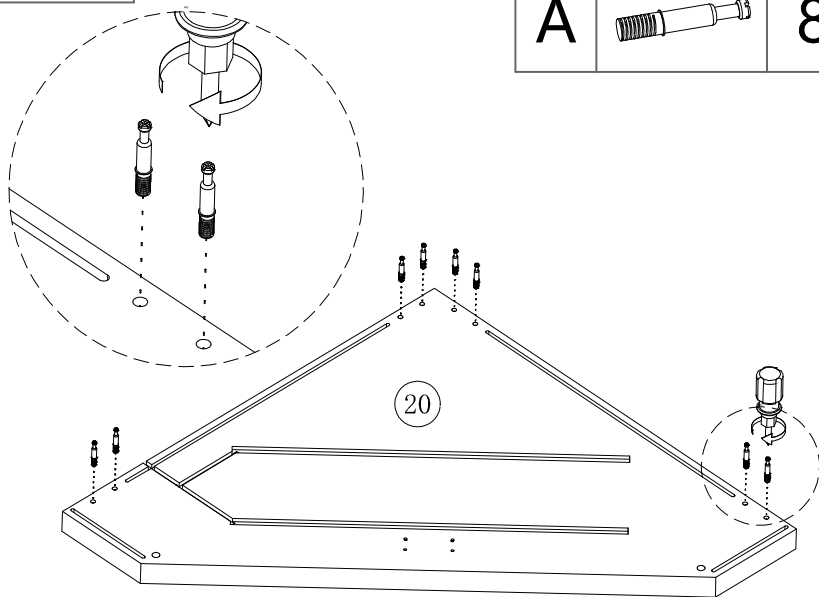
code	Diagram	count
A		8

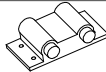

Step30

code	Diagram	count
G		1
G	 3X16mm	4

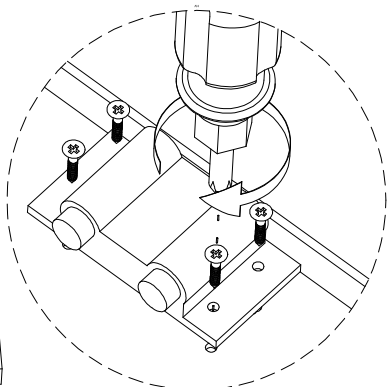
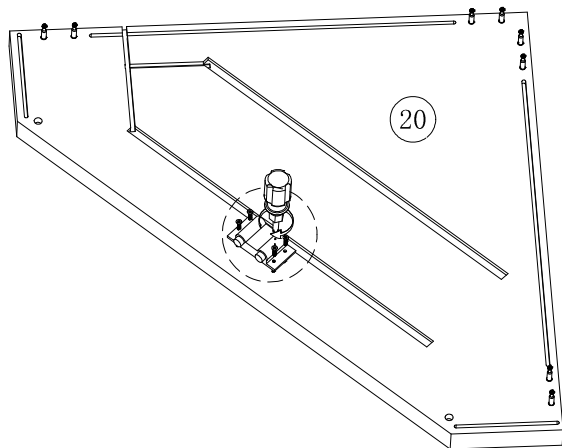

16

Step31

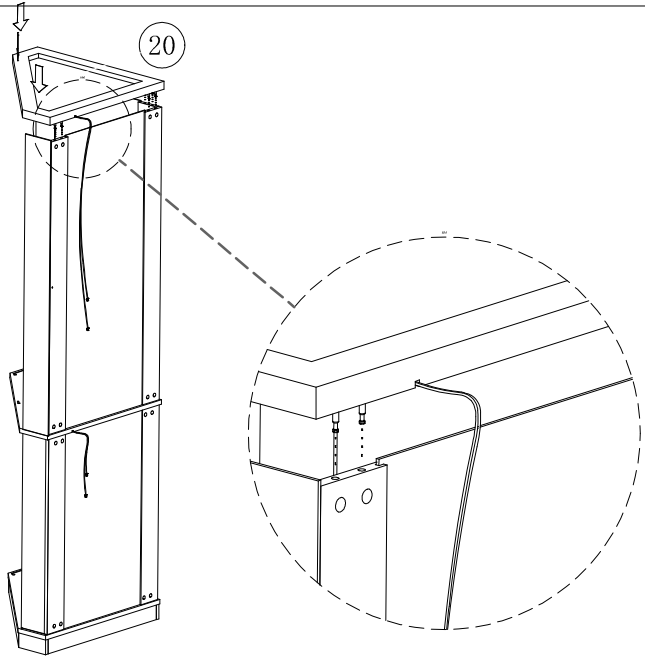

Step32

code	Diagram	count
B		1

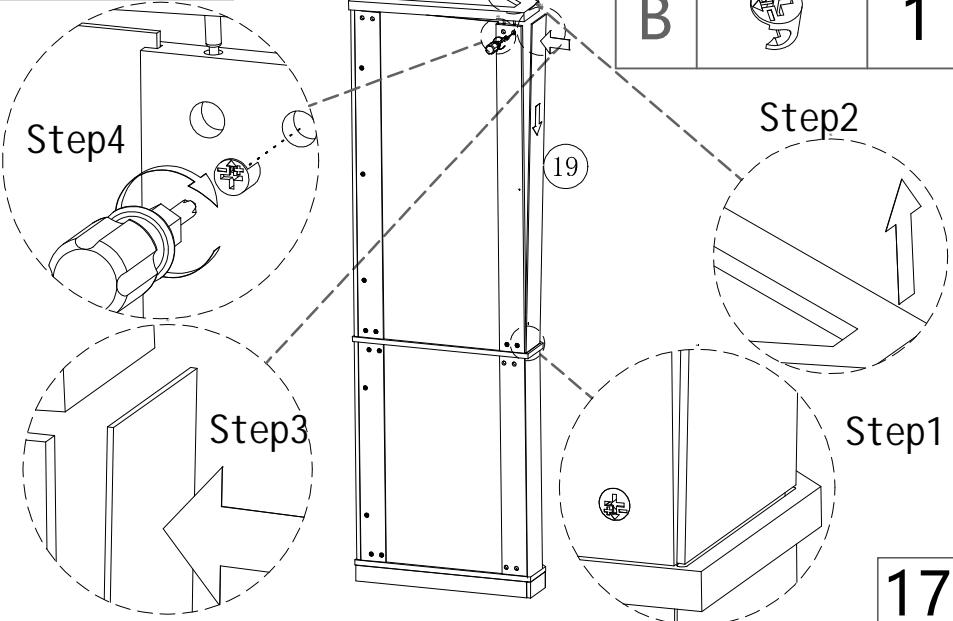

Step33

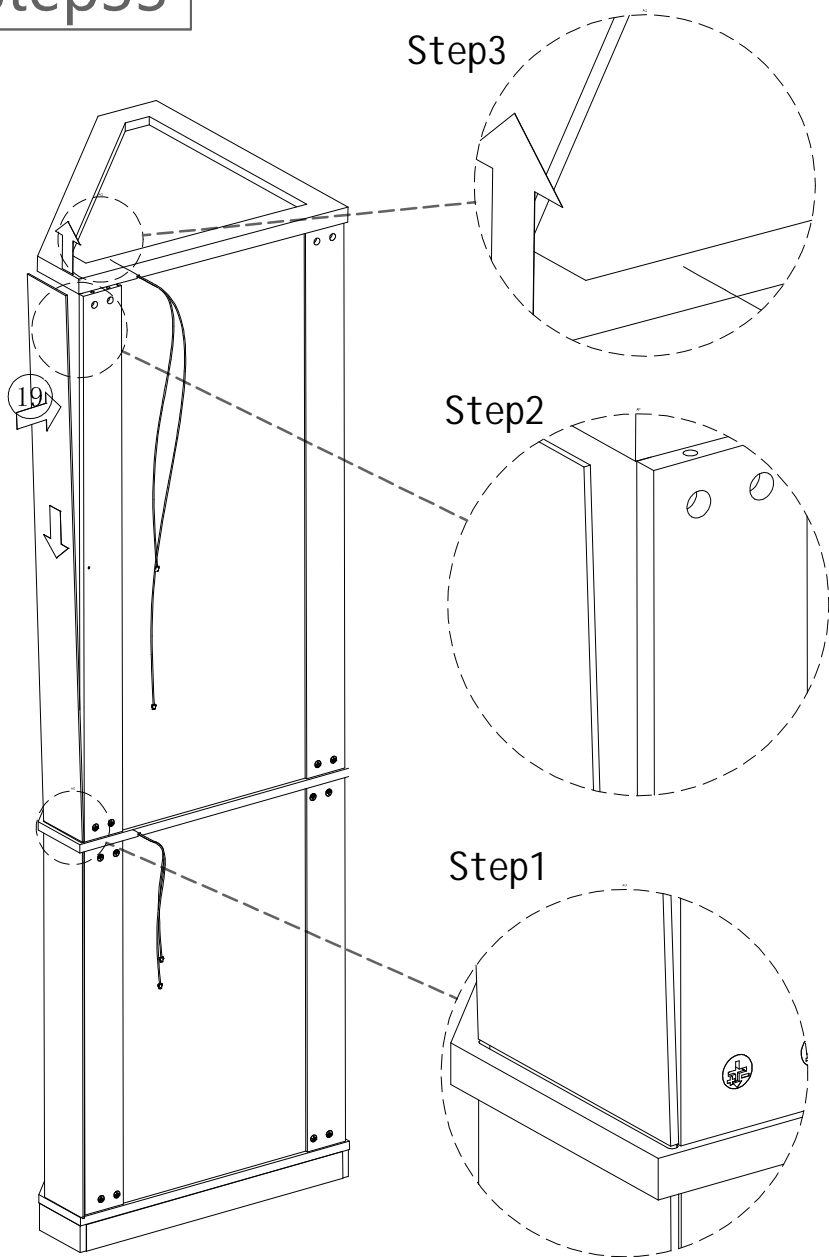

Step34

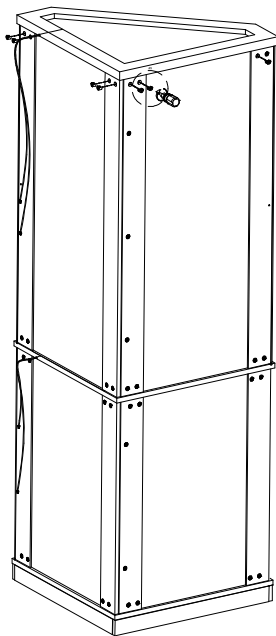

code	Diagram	count
B		7

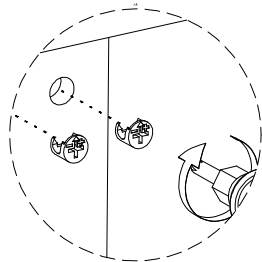

Step35

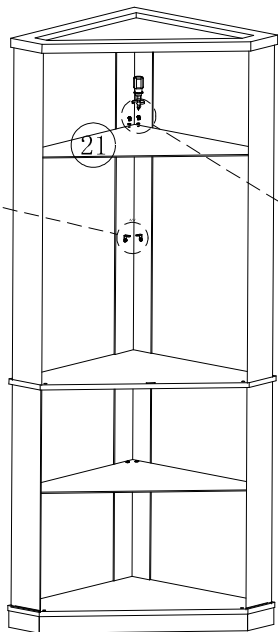

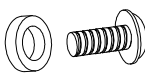
code	Diagram	count
E		4

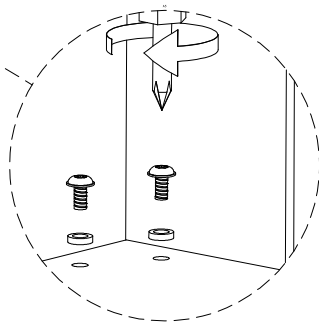
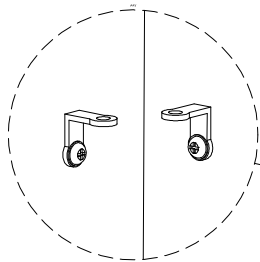

Step36

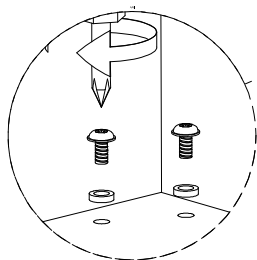
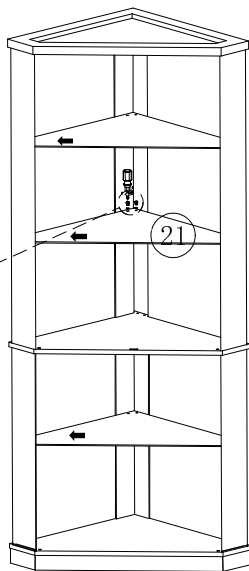

code	Diagram	count
E		4

Install the glass shelf board as indicated by the arrow

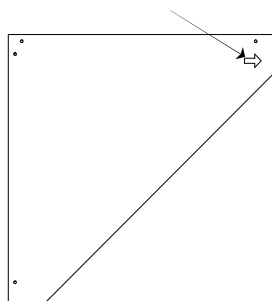

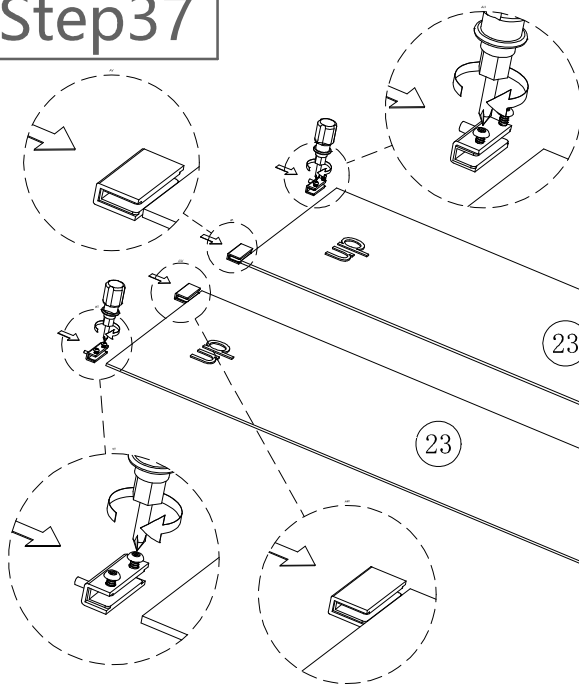

The installation direction of the glass, as indicated by the arrow.

Step37

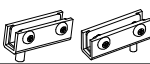

code	Diagram	count
G		1
G		2

Step38

code	Diagram	count
G		1
G		4

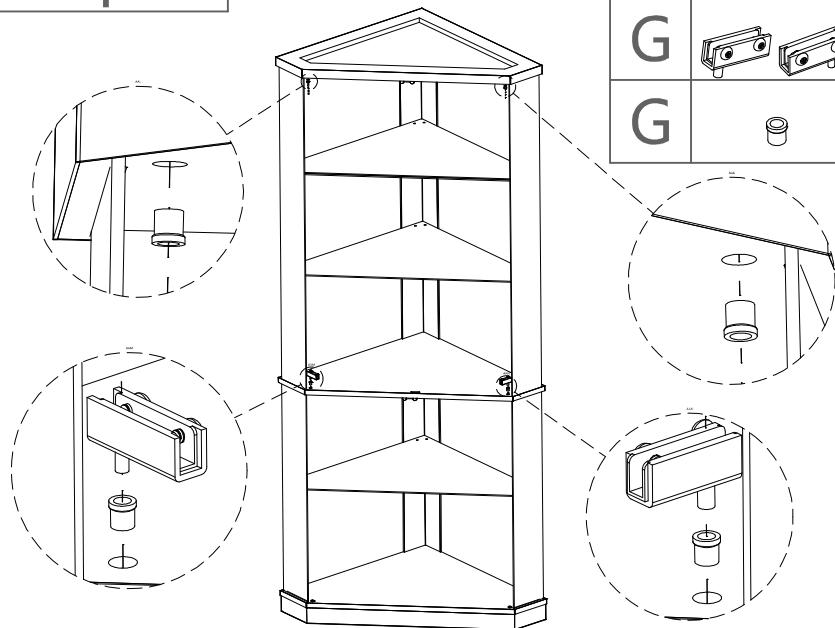

Step39

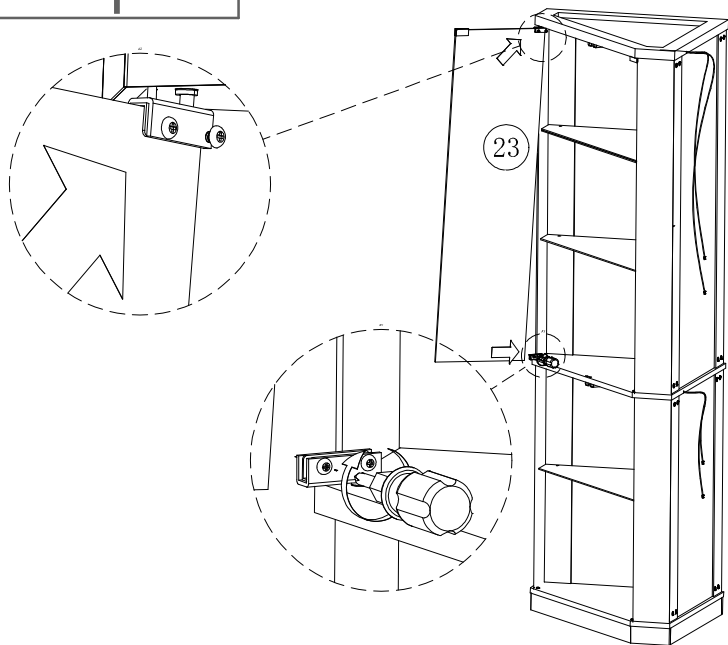

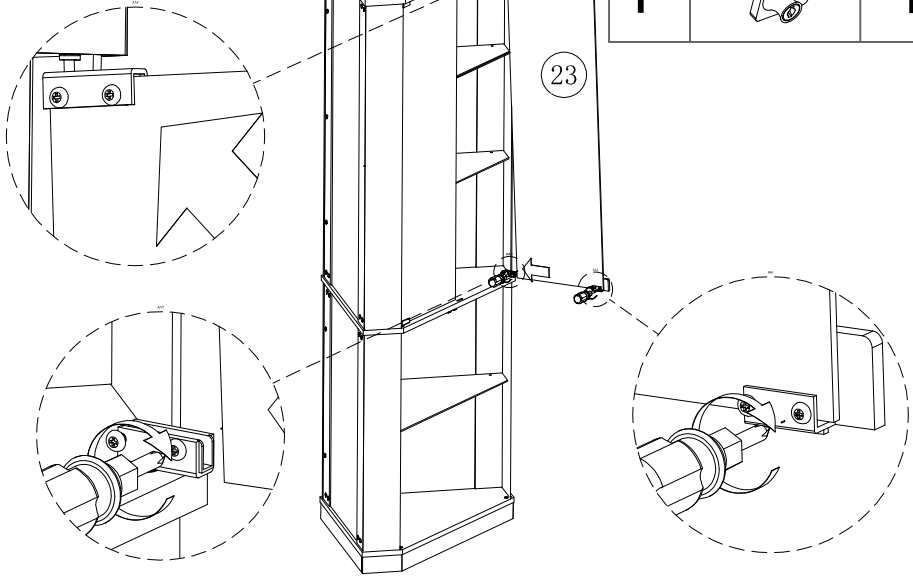

Step40

code	Diagram	count
F		1



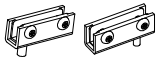

Step41

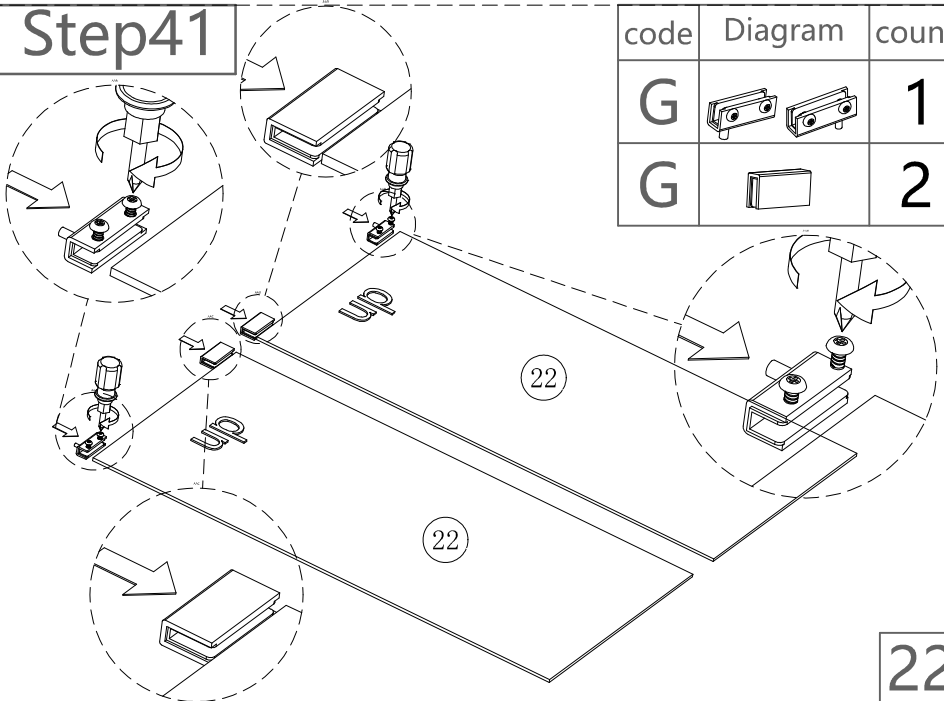
code	Diagram	count
G		1
G		2

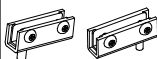

Step42

code	Diagram	count
G		1
G		4

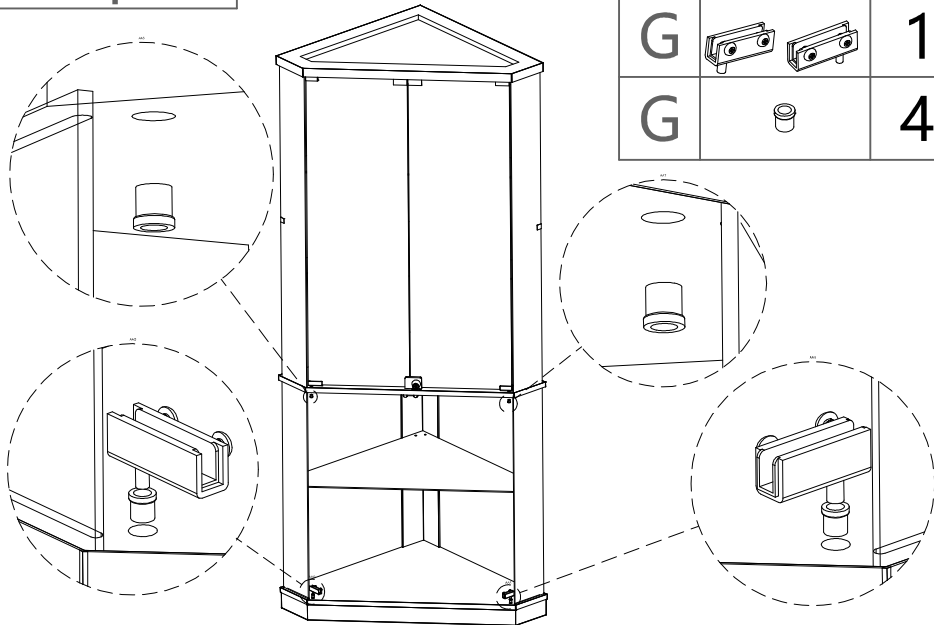

Step43

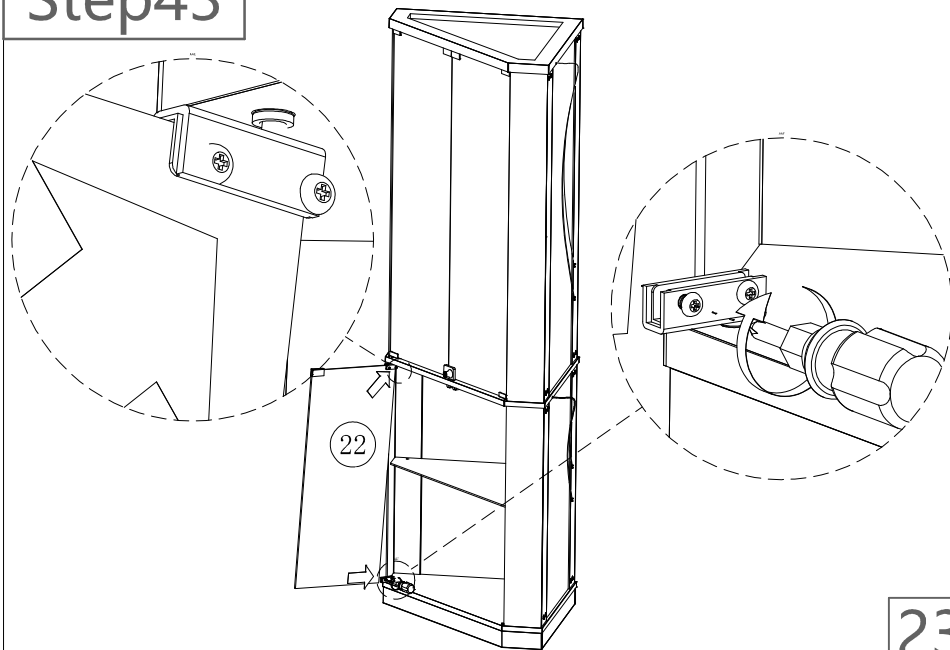

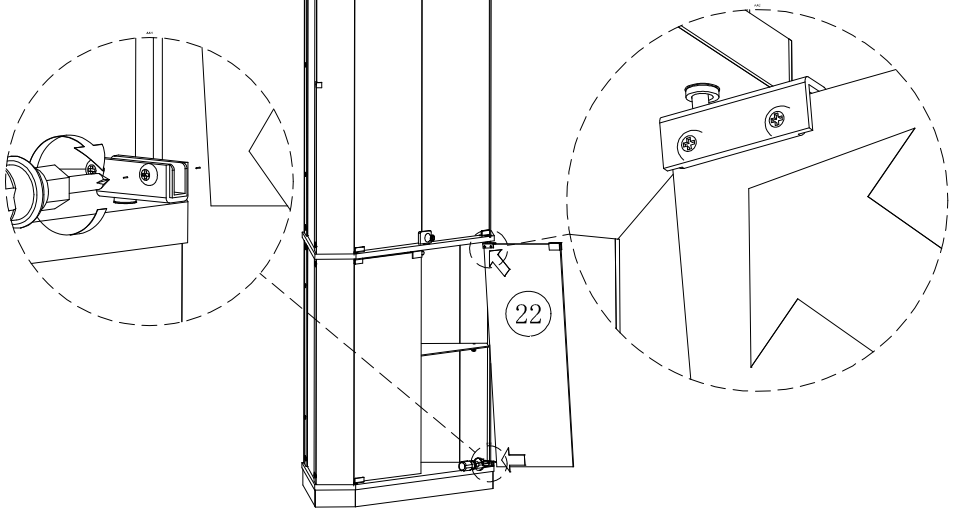

Step44



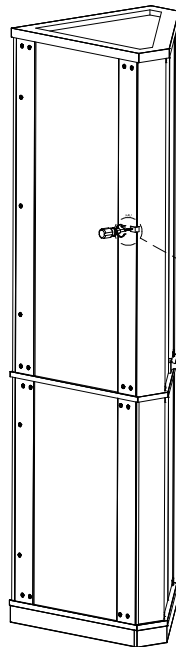

Step45



code	Diagram	count
H		1
H		1

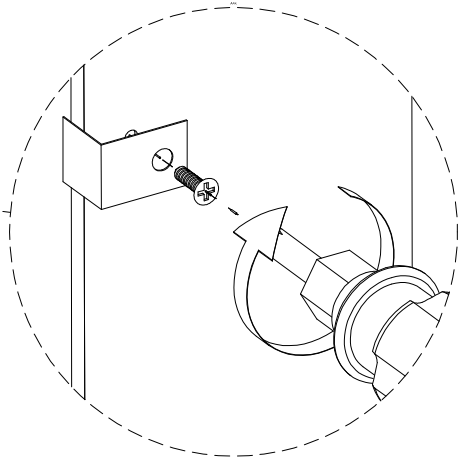
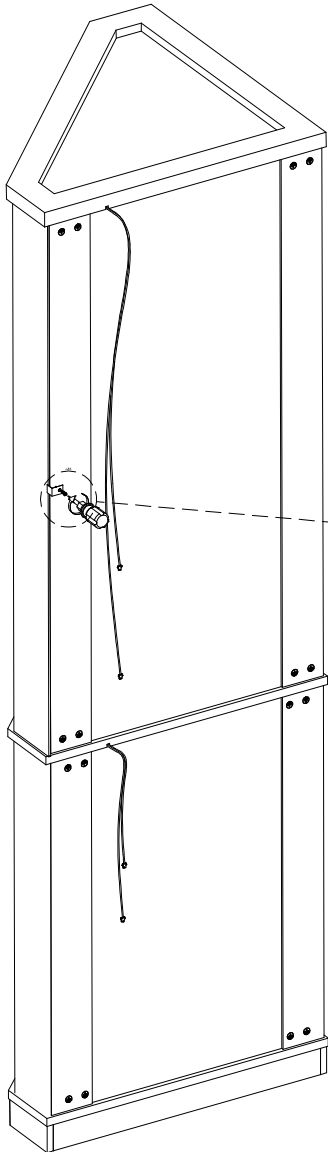

Step46

code	Diagram	count
H		1
H		1



Step47

Connect the lamp wires.

code	Diagram	count
L		3
M		1
O		3

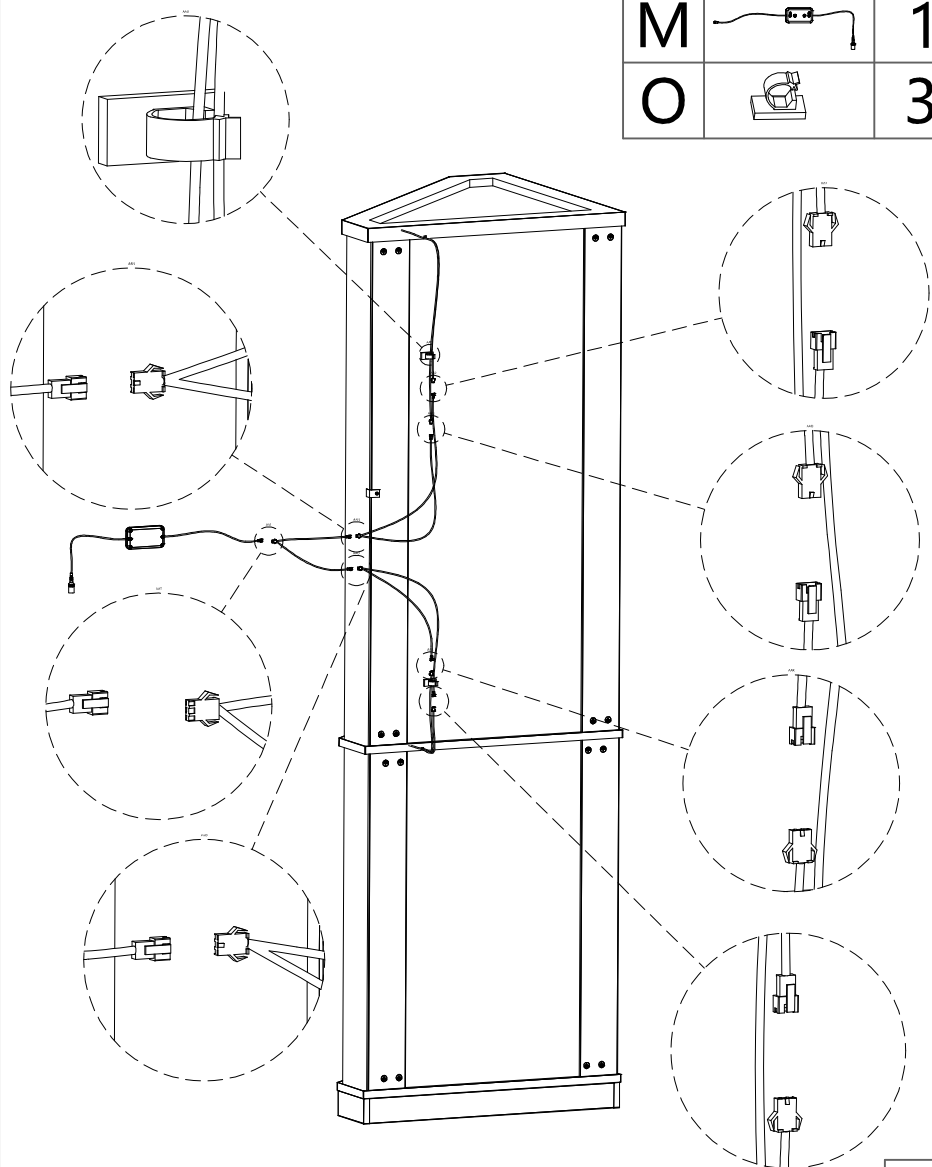

Step48

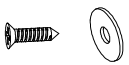
code	Diagram	count
K		2
K		2

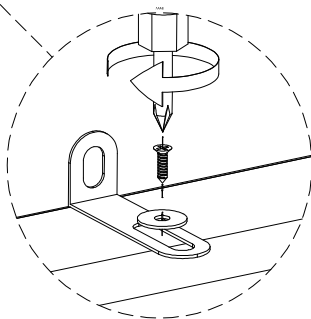
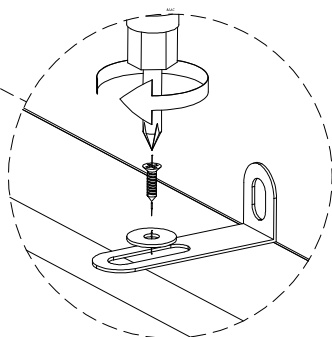
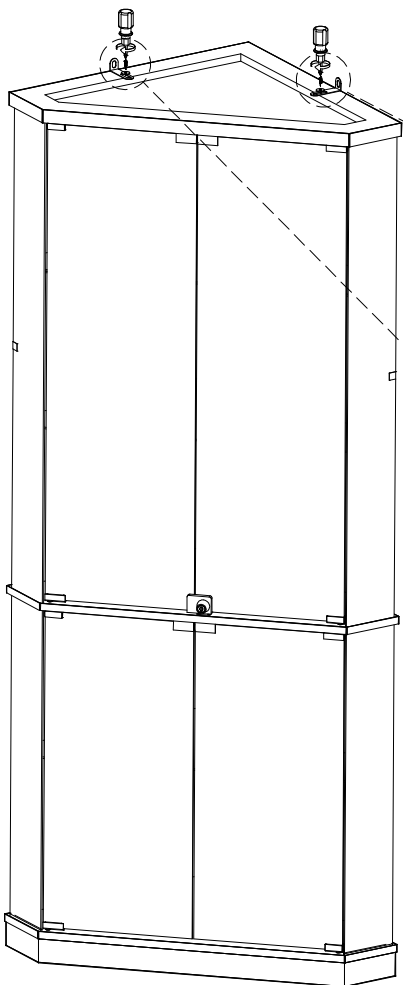

Step49

Mark hole locations with a marker pen

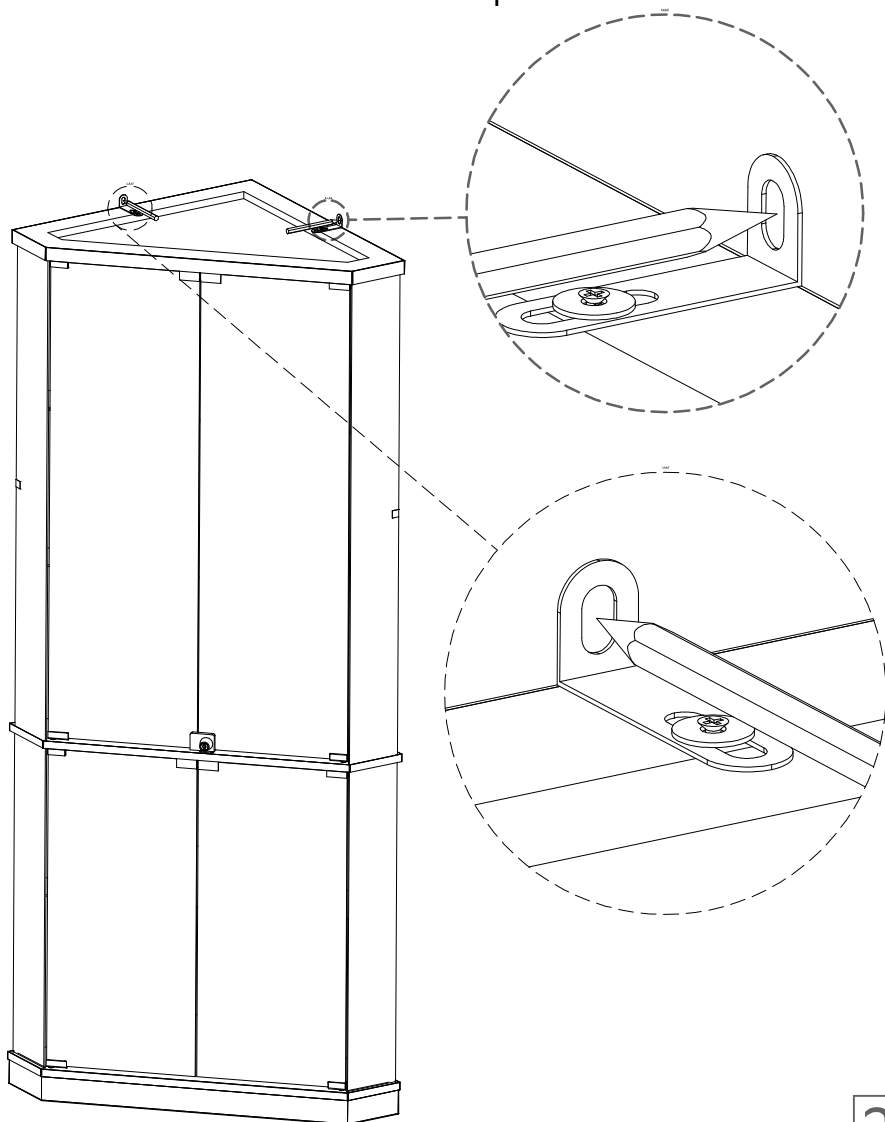

Step50

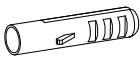
code	Diagram	count
K		2

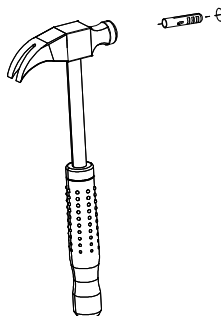
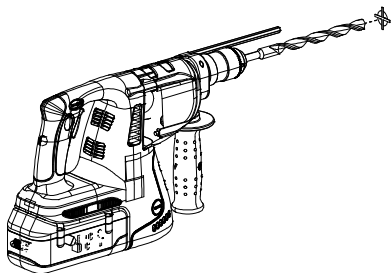

Drill a hole in the wall with an impact drill. Hammer drive in an expansion plug.

Step51

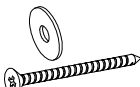
code	Diagram	count
K		2

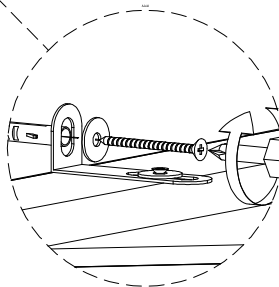
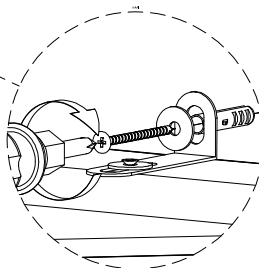
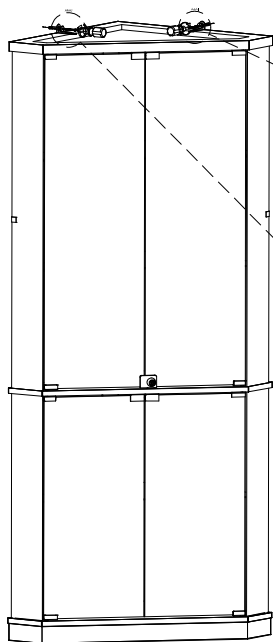

Step52

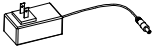
code	Diagram	count
N		1

Connect to power

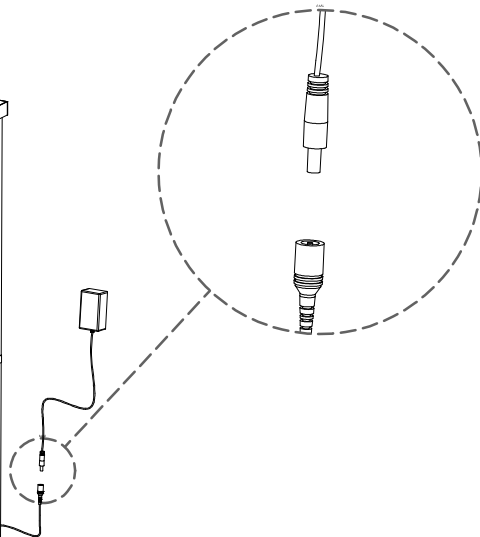
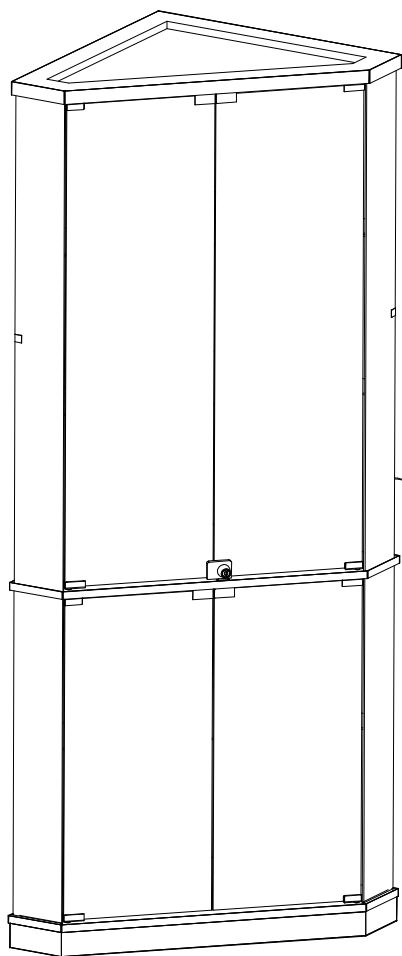

User's Guide

Thank you for purchasing this product.

To use this product, please plug it into a 12V DC power supply.

Please use if the product works normally after connecting to power.

Introduction

The box is an intelligent controller. With 4 touch buttons, it can turn ON/OFF the light and turn ON/OFF the induction function, change light colors, and adjust the light luminance.

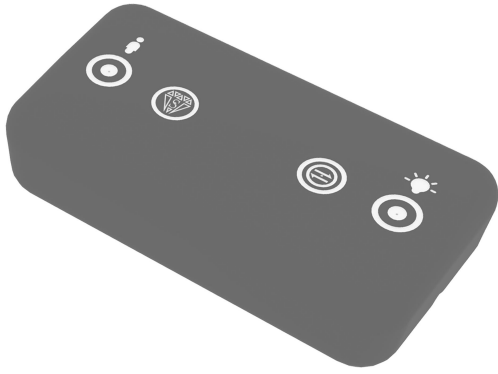

Operation



This touch button is the master switch of the smart box,

which can turn off all functions of the box and control the light strips on/off operation.

The operation that can be turned on and off with just a light tap. Press and hold to adjust the brightness.

Upon first power-up, the default light will be set to white.



This touch button is used to turn on/off the induction function.

A. touch this button once to turn on the induction function (indicator light on).

After the person leaves or remains stationary for more than 30 seconds, the light strip goes out; people and objects within a range of 1 meters move will light up the light strip.

B. Long press this button for 0.5 seconds to turn off the human body induction function (the indicator light goes out).

At this point, keep the light strip as it was before turning off and no longer be affected by human and object activities.

By default, induction function is enabled when powered on.



This touch button is the Dynamic Phantom Color Mode, which includes 5 magical lighting effects.

Simply tap to cycle through the options. (Attention: This mode cannot adjust the brightness)



This touch button controls the single-color switching function of the light strips,

offering 7 different colors to choose from.

Phantom Color Mode Button

7-Color Mode Button

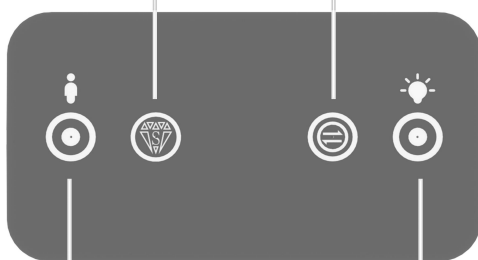

Induction Button

Master Switch Button



ATTENTION PLEASE

1. If there is no touch response suddenly, Re-plug the power to reset the touch static electricity.
2. If you have any questions when installing, please feel free to contact us. Thank you.