

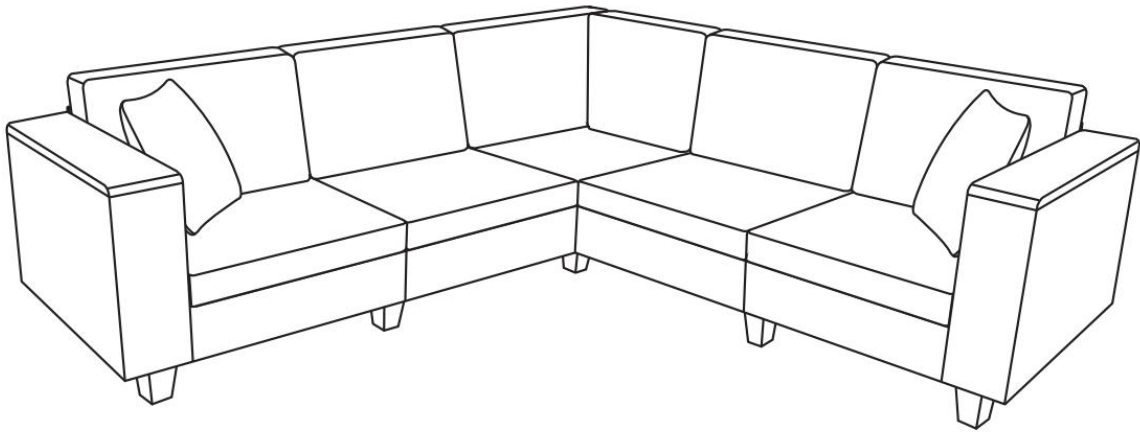





Assembly Instructions



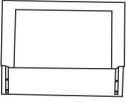
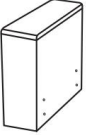

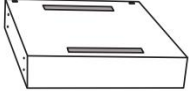
Note: Please help to read my instruction before you ready to assemble.

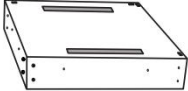
SOFA

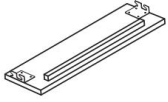
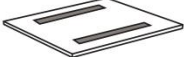

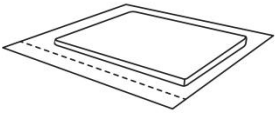
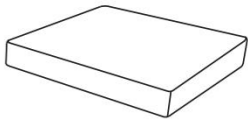









Part List

Label	Picture	Description	QTY (PCS)
A		Backrest	6
B		Left Armrest	1
C		Right Armrest	1
D		Left Seat Frame	1
E		Right Seat Frame	1
F		Corner Seat Frame	1
G		Back Rail	2
H		Front Rail	2
I		Seat Panel	2

J		Seat Cushion Package	5
J1		Seat Cushion	5
K		Back Cushion	5
L		Corner Back Cushion	1
M		Pillow	2
N		Leg	12

Hardware

①		Wood dowel (M6)	8
②		"L" Iron Connect Plate	4
③		Plastic Washer	13
④		Screw Arbor(M8*70mm)	9
⑥		Bolt (M8*20mm)	9

⑦		Bolt (M8*40mm)	25
⑧		Flat Washer	33
⑨		Spring Washer	33
⑩		Nut	9
⑪		Spanner	1
⑫		Allen Wrench (S5)	1

NOTICE:

- Please read the instruction from cover to cover in detail.Thanks.
- Installed by at least two adults
- To avoid damaging your furniture , Please don't assemble on flooring or carpet.
- Please assemble on a clean non-marring surface, example for packing foam.
- Saving all packaging until have finished.

Assembly Steps:

OVERVIEW

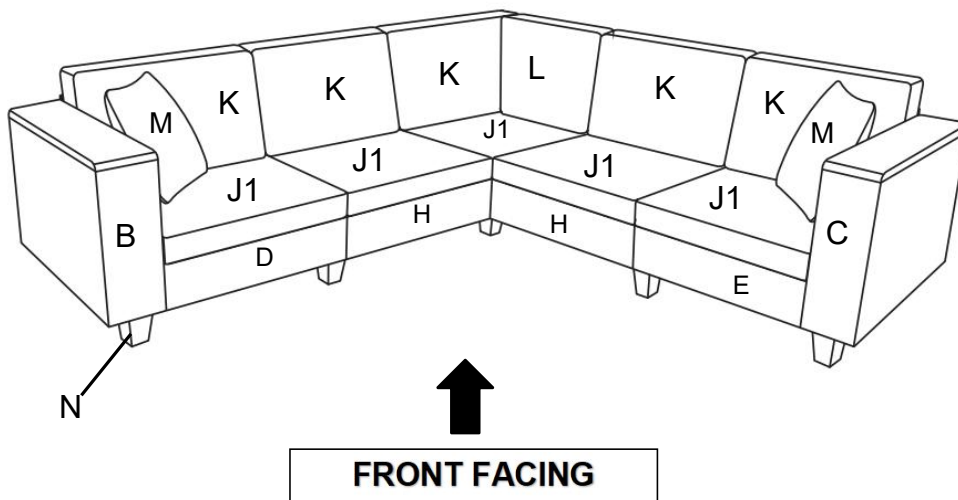

This SOFA has multiple parts and may require up to 45 minutes to assemble. To give you an overview of the SOFA parts, the above picture is to help you put the various parts into perspective. Please read through the instructions below to familiarise yourself with the parts and steps before assembly.

Note: It is recommended that you have an adult partner to assist during the entire assembly process.

Step 1

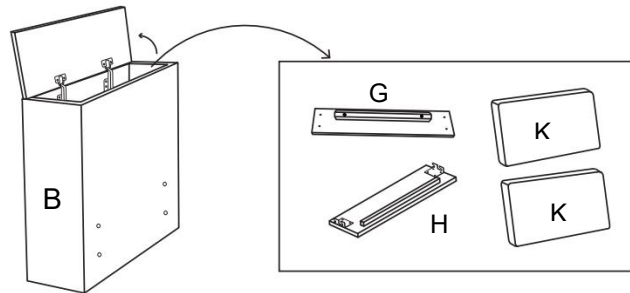

Remove Back Rail (G), Front Rail (H) and two Back Cushions (K) from Left Armrest (B).

Step 2

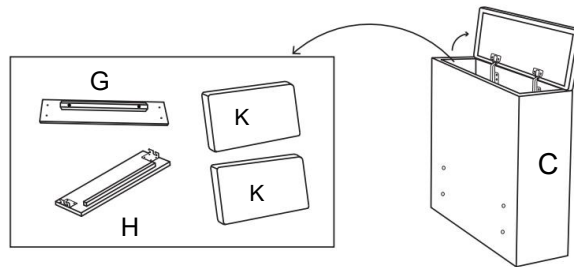

Remove Back Rail (G), Front Rail (H) and two Back Cushions (K) from Right Armrest (C).

Step 3

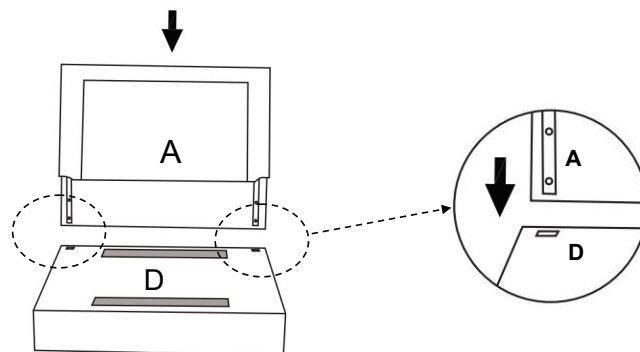

Insert the Backrest (A) into the Left Seat Frame (D).

Step 4

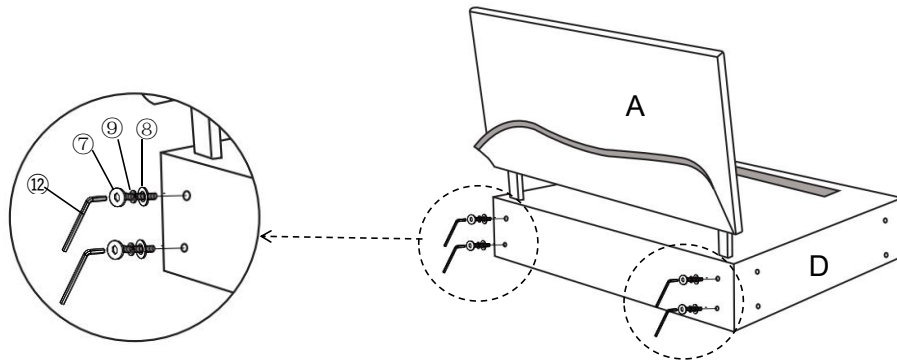

Then using Bolt(7) Sping Washer (9)Flat Washer(8) with Allen Wrench(12),turning clockwise until tight as shown.

Step 5

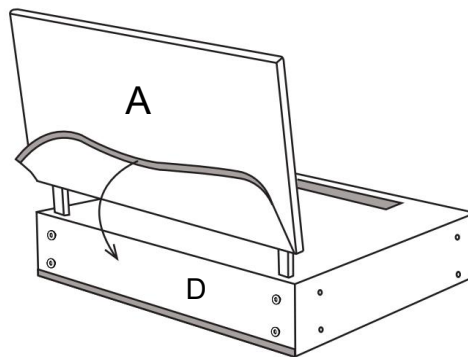

Attach the magic tape to the back of the Left Seat Frame(D).

Step 6

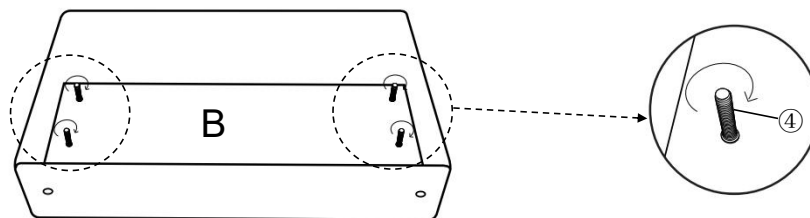

Insert the short end of four Screw Arbor(4) into Left Armrest (B), and turning clockwise until tight as shown.

Step 7

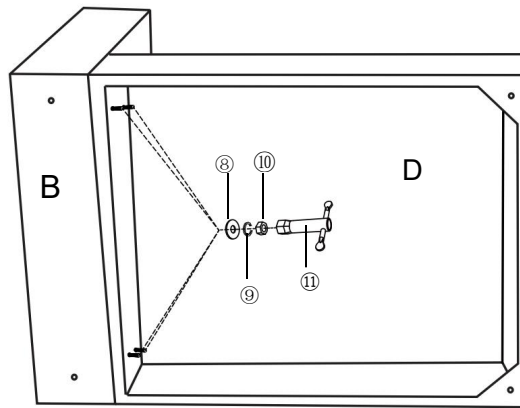

Install the Left Armrest(B) to Left Seat Frame(D) by using Nut (10) Spring Washer (9) Flat Washer(8) with Spanner(11), turning clockwise until tight.

Step 8

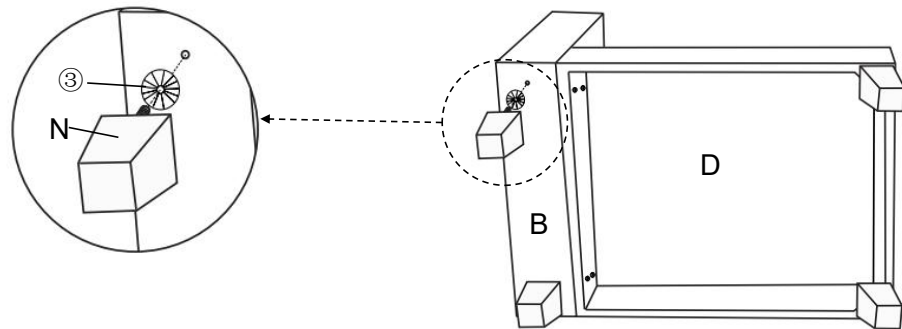

Install the Leg(N) at the bottom of Left Seat Frame(D) and Left Armrest(B) by placing Plastic Washer(3) on the threaded stem. Then insert the threaded stem into the threaded mounting position at the bottom of Left Seat Frame(D) and Left Armrest(B), turning clockwise until tight.

Note: The use of Plastic Washer(3) are OPTIONAL and are especially useful to help alleviate slight wobbleness. Some Legs may need more than one Plastic Washer(3) whilst some Legs may not need any.

Step 9

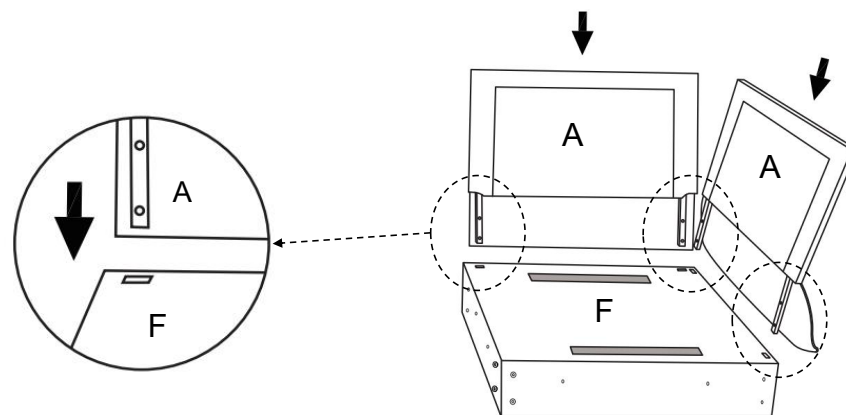

Insert the Backrest (A) into the Corner Seat Frame(F).

Step 10

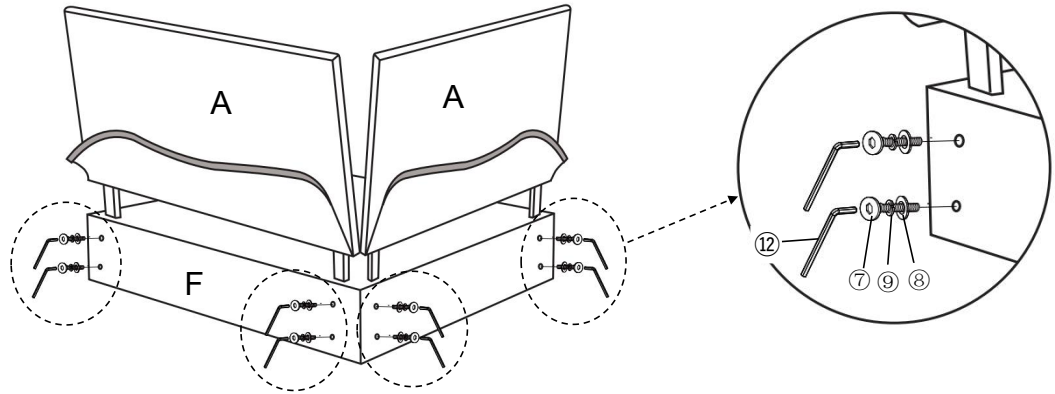

Use Bolt(7) Sping Washer (9)Flat Washer(8) with Allen Wrench(12),and turn clockwise until tight as shown.

Step 11

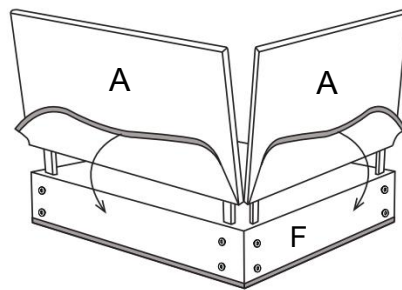

Attach the magic tape to the back of the Corner Seat Frame(F).

Step 12

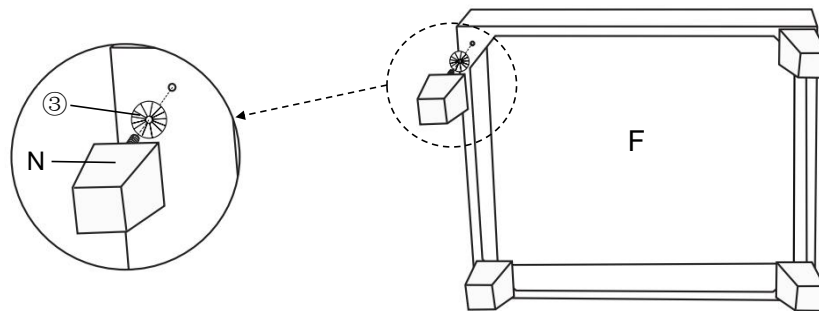

Repeat step 8 to install the Legs (M) on Corner Seat Frame(F).

Step 13

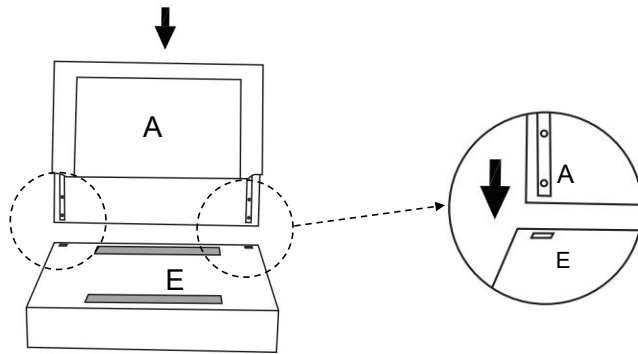

Insert the Backrest(A) into the Right Seat Frame(E).

Step 14

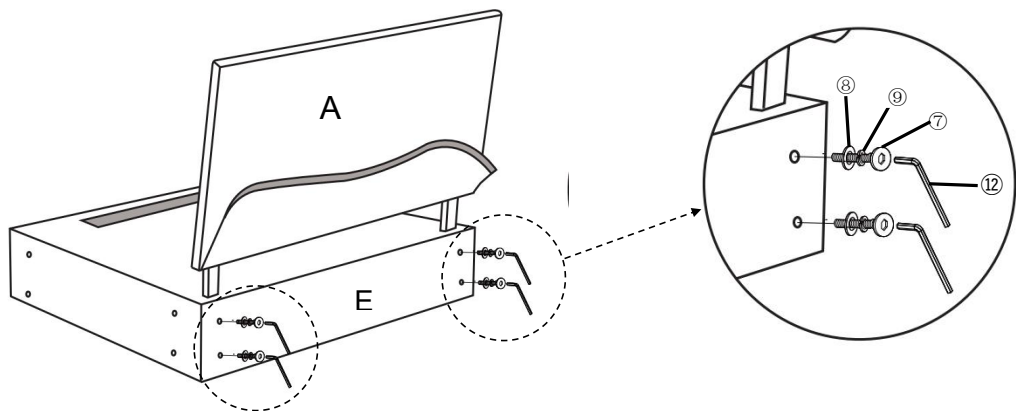

Use Bolt(7) Sping Washer (9)Flat Washer(8) with Allen Wrench(12),and turn clockwise until tight as shown.

Step 15

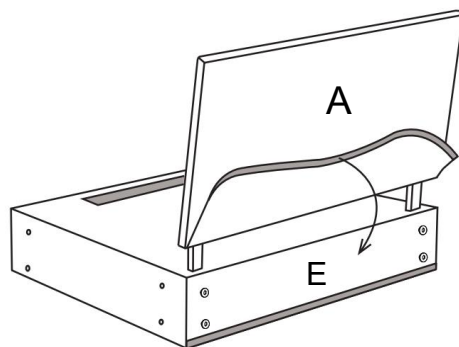

Attach the magic tape to the back of the Right Seat Frame(E).

Step 16

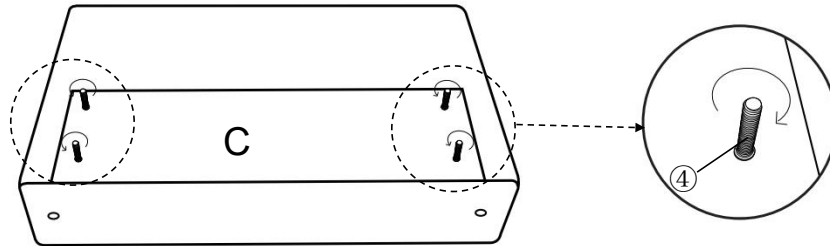

Insert the short end of four Screw Arbor(4) into Right Armrest (C), and turning clockwise until tight as shown.

Step 17

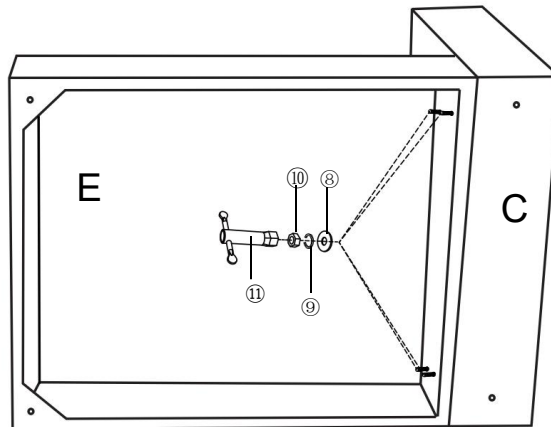

Install the Right Armrest(C) to Right Seat Frame(E) by using Nut (10) Spring Washer (9) Flat Washer(8) with Spanner(11),turning clockwise until tight.

Step 18

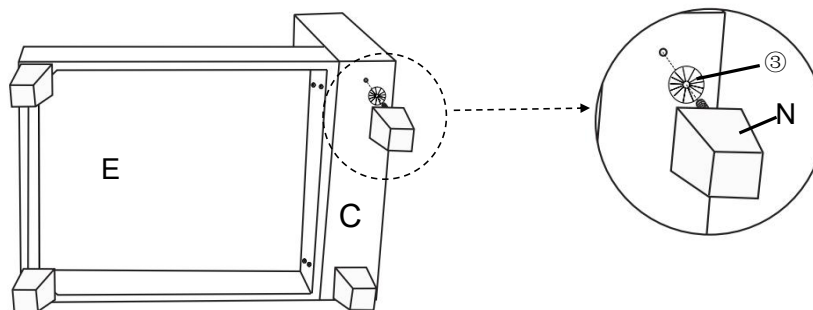

Repeat step 8 to install the Legs (M) on Right Seat Frame(E).

Step 19

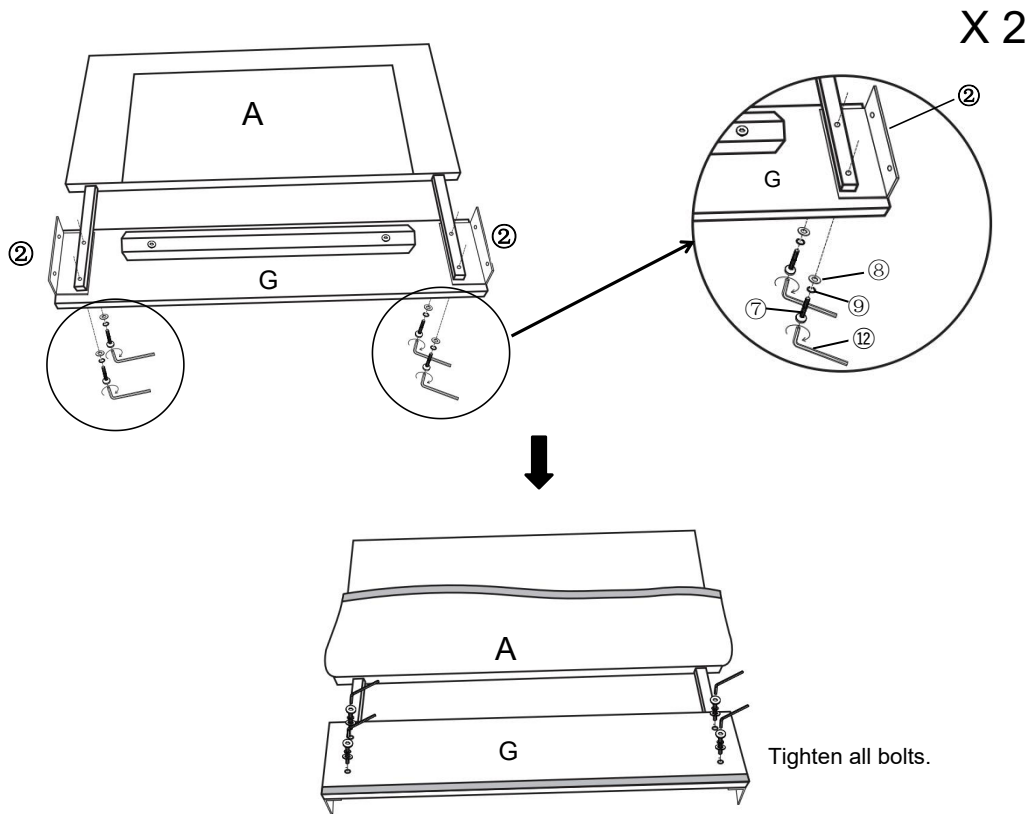

Install the Backrest(A) and Back Rail (G) by using "L " Iron Connect plate(2), then using Bolt(7) Sping Washer (9) Flat Washer(8) with Allen Wrench(12), then turn over and tighten all bolts clockwise. Repeat this step with the other one.

Step 20

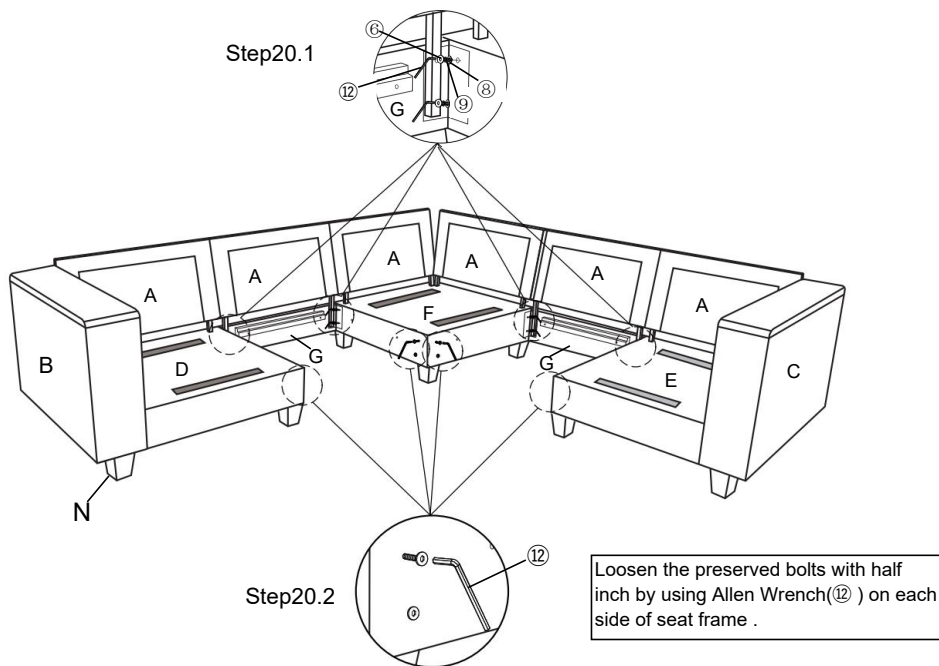

Step20.1 Connect the Left Seat Frame(D)to the Corner Seat Frame(F)with Semi-assembly Parts(Step 19) by using Bolt (6), Sping Washer (9) Flat Washer(8) with Allen Wrench(12),turning clockwise until tight. Repeat this step with the Right Seat Frame(E).

Step20.2 Loosen the preserved bolts with half inch by using Allen Wrench(12) on each side of seat frame .

Step 21

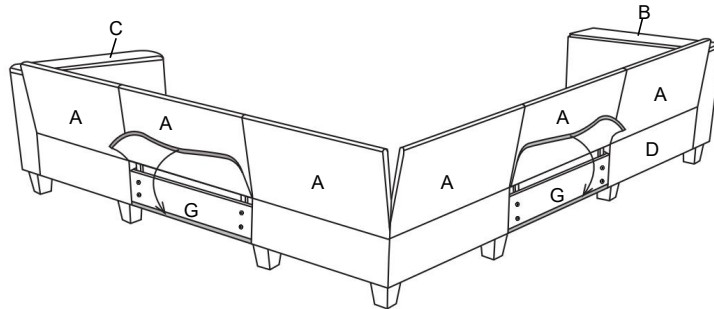

Attach the magic tape to the back of the Back Rail (G).

Step 22

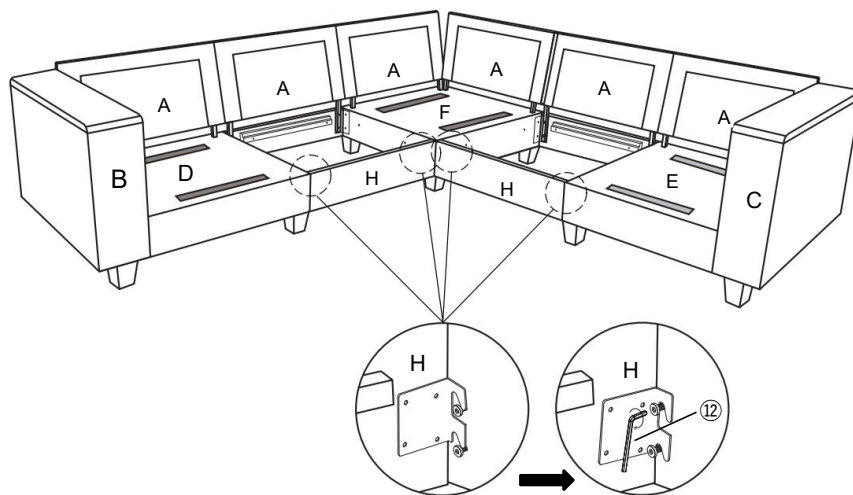

Slide the hook of Front Rail(H) into the bolts on the side of seat frame as picture shown, then tighten the bolts.

Step 23

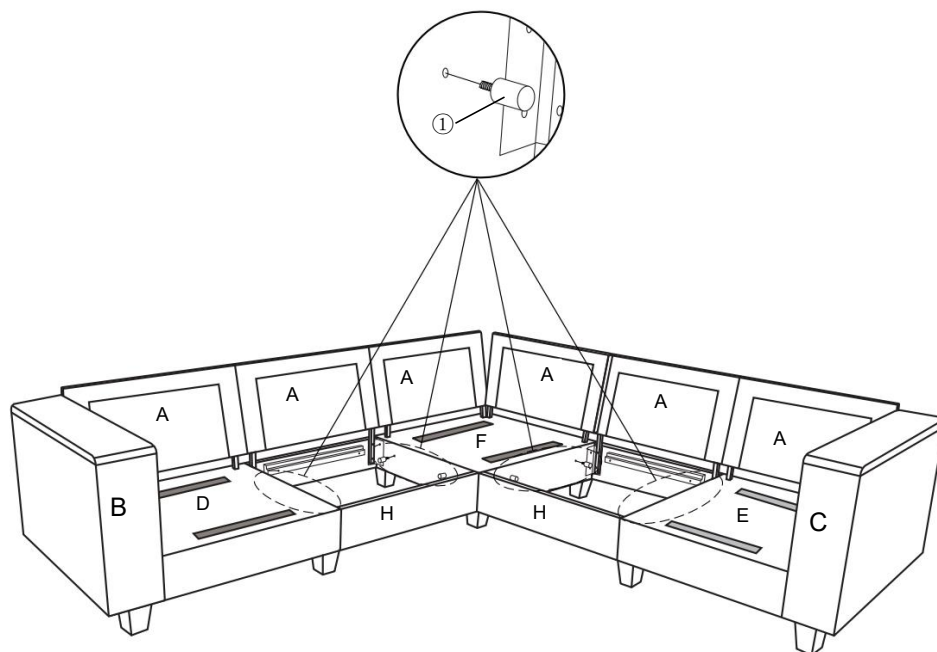

Install eight Wood dowels (①) into the preformed hole of Seat Frame(D),Seat Frame(E) and Corner Seat Frame (F).

Step 24

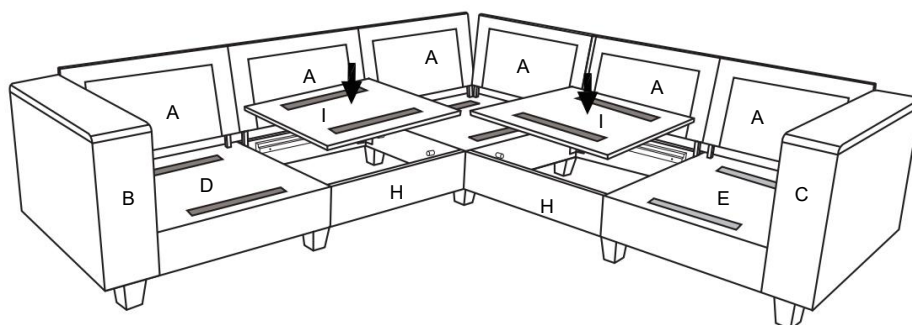

Put the Seat Panels (I) on the middle positions.

Step 25

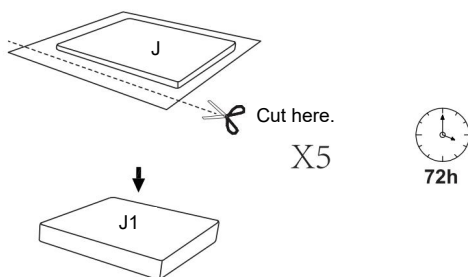

Cut the Seat Cushion Packages (J) , then take out Seat Cushions (J1).Full decompression may take up to 72 hours.

Step 26

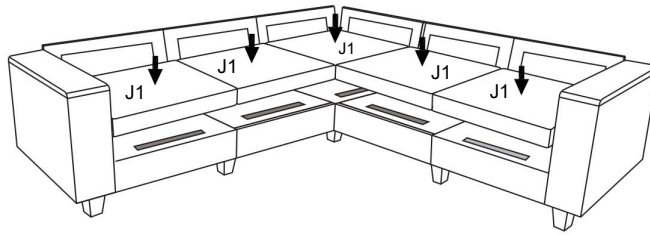

Put the Seat Cushions (J1) on your sofa.

Step 27

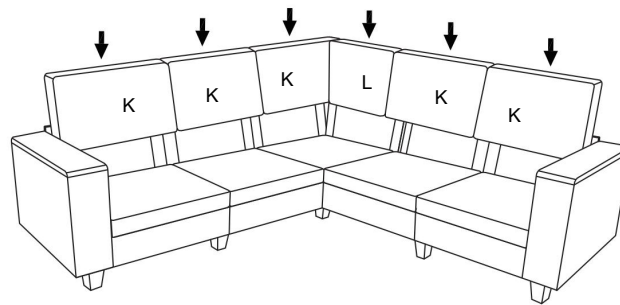

Put the five Back Cushions (K) and one Corner Back Cushion (L) on your sofa.

Step 28

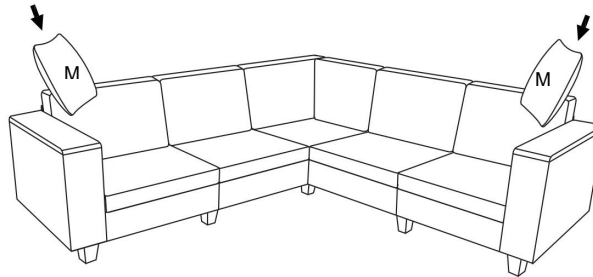

Put the Pillows (M) on your sofa.

COMPLETE

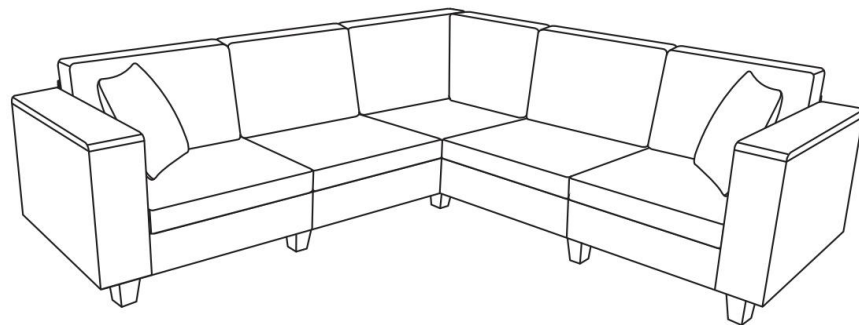

Your sofa is ready for use !