

ASSEMBLY INSTRUCTIONS

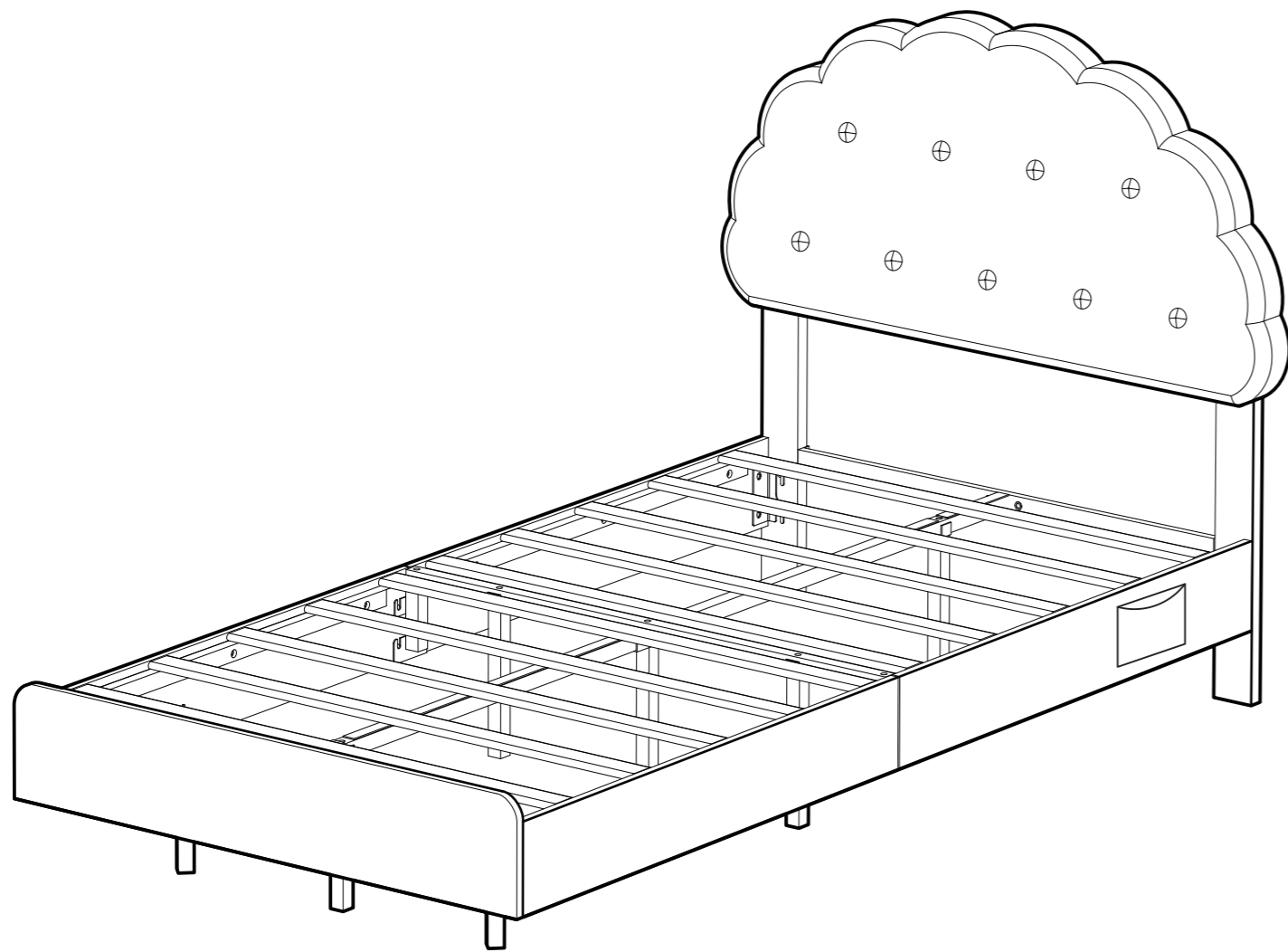

WARNING

- Carefully read and follow all instructions. Save for future reference.
- Intended for indoor use only. Do not leave the bed outdoors.
- This product is to be assembled by an adult. Children are not allowed to assemble the product. Keep unassembled and small parts out of reach of children.
- Follow the instructions for assembly and use. We shall not be liable for damage or injury resulting from improper assembly or use.
- DO NOT use if any part is missing or damaged.
- DO NOT allow children to jump on the bed.
- DO NOT place near ignition or heat sources.
- Keep away from sharp objects and corrosive chemicals.
- Fully tighten all bolts and screws before use. Bolts and screws may become loose after long period of use. Regularly check and make sure all bolts and screws are fully tightened.
- Clean with a soft, slightly damp cloth. In case of stubborn stains, carefully clean with nonabrasive sponge.
- Dispose of all packaging materials properly. Keep away from children and pets. Keep plastic bags away from babies and small children.

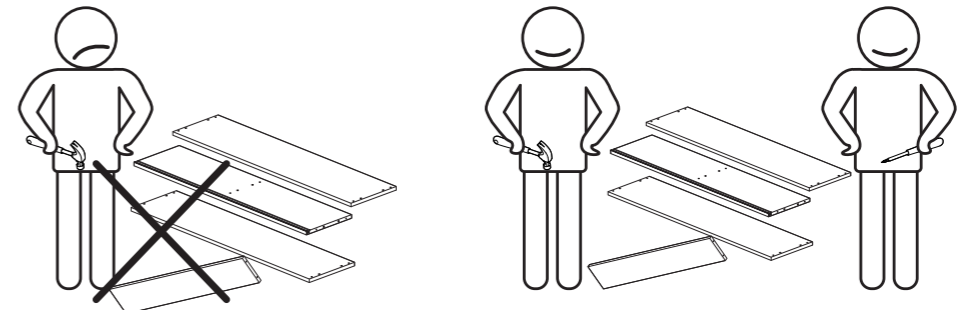

We recommend at least 2 people for the assembly.



Any questions concerning assembly, contact us





PARTS DIAGRAM

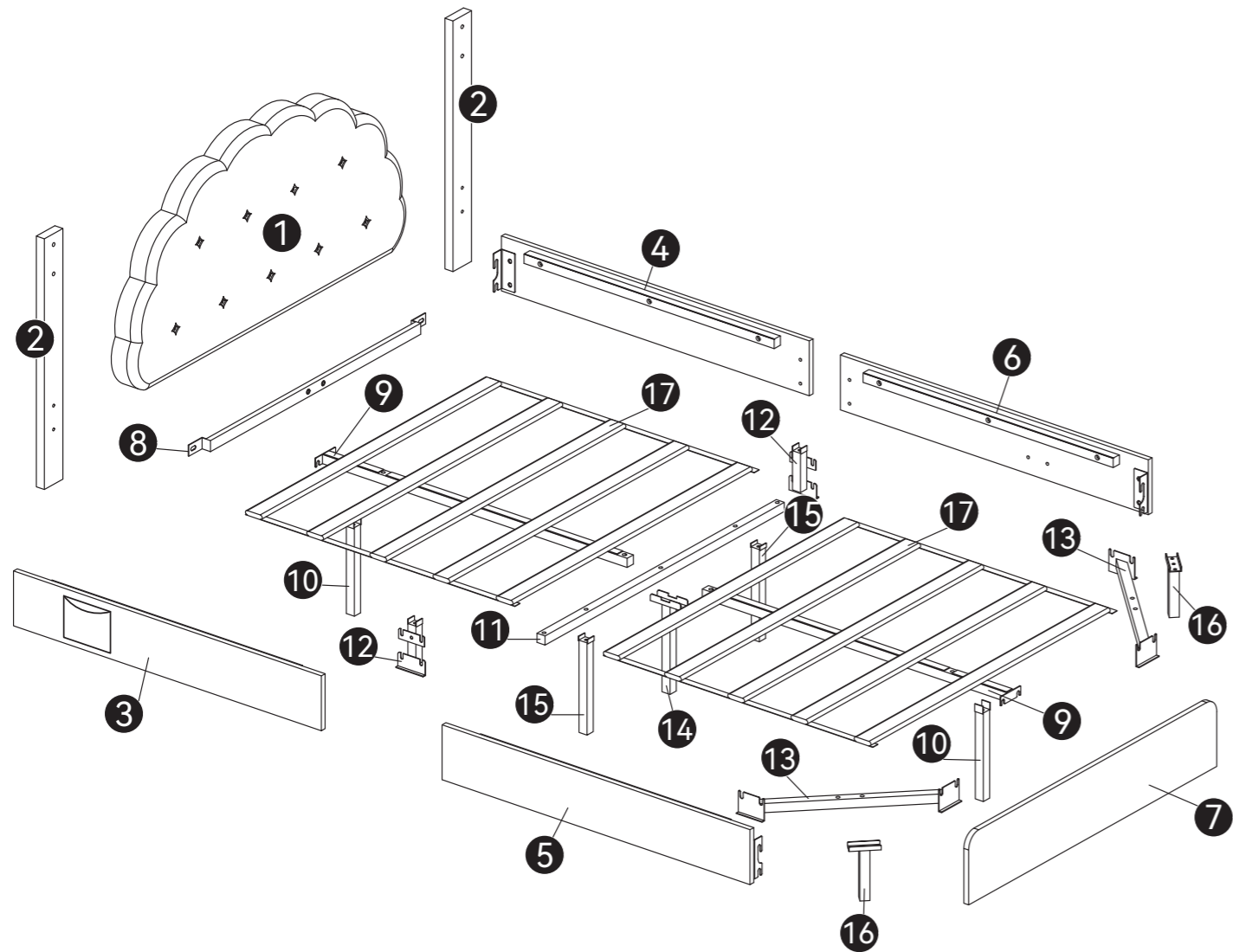

Check if all parts and hardwares are included. Contact us if there is any part missing or damaged.

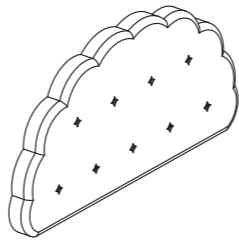
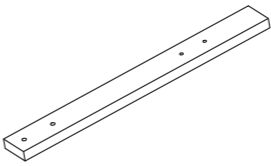
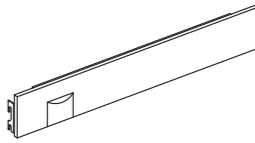
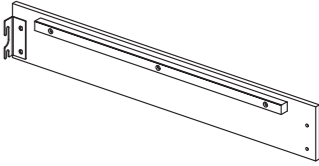
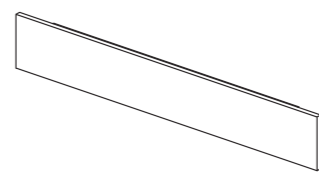
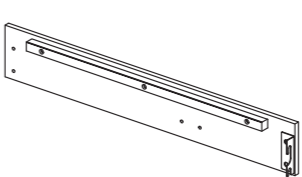
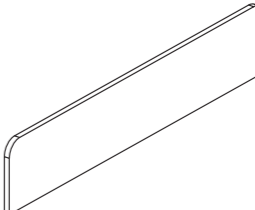
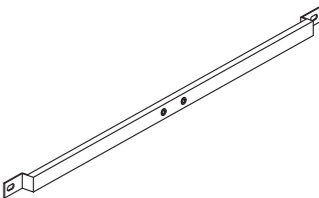
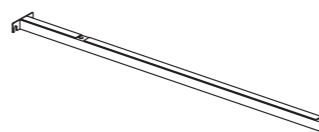

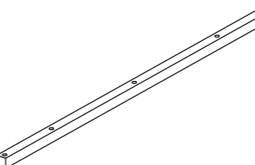
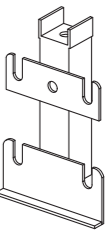
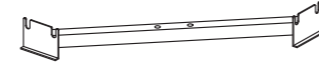
PARTS LIST

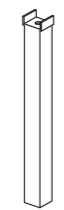
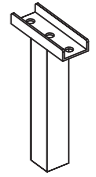
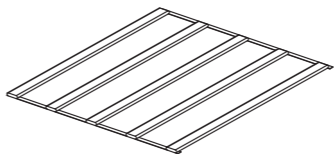
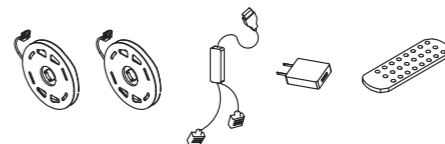
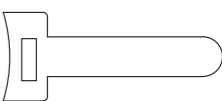
			
1 x 1	2 x 2	3 x 1	4 x 1
			
5 x 1	6 x 1	7 x 1	8 x 1
			
9 x 2	10 x 2	11 x 1	12 x 2
			
13 x 2	14 x 1	15 x 2	16 x 2
			
17 x 2	18 x 1		19 x 4

HARDWARES



M8x40mm

A x 4



M8x15mm

B x 30

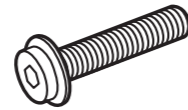

M8x45mm

C x 3

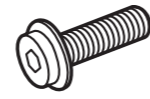

M8x35mm

D x 10

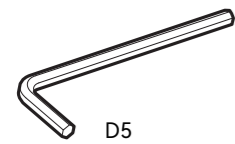

D5

E x 1

SPARE PARTS



The spare parts are the additional parts provided in case of missing or damaged ones. Keep the spare parts and tools for future use.

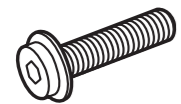

M8x40mm

A x 1



M8x15mm

B x 2

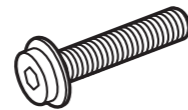

M8x45mm

C x 1



M8x35mm

D x 2

1

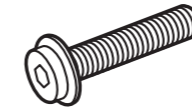

A x 4

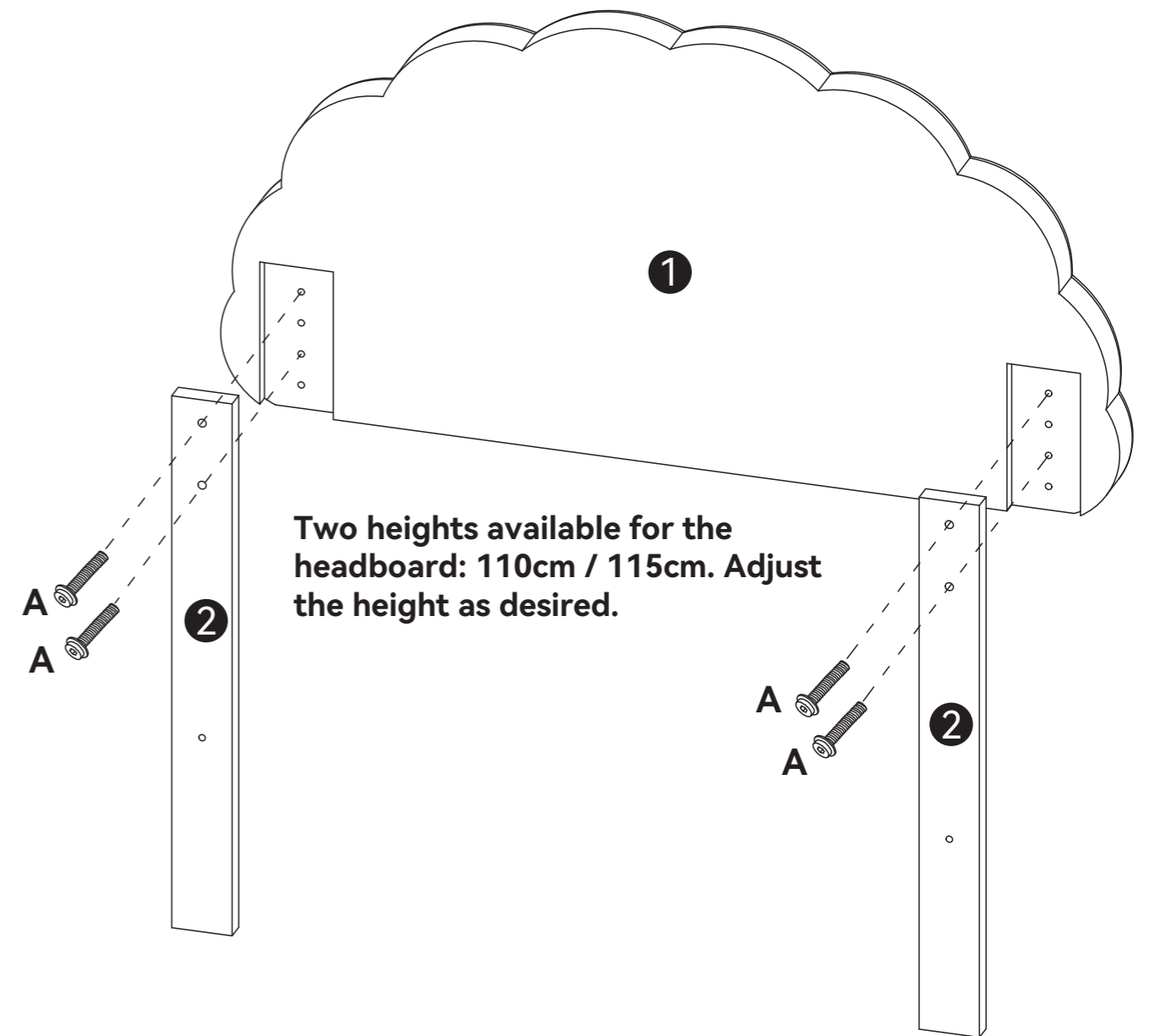

2

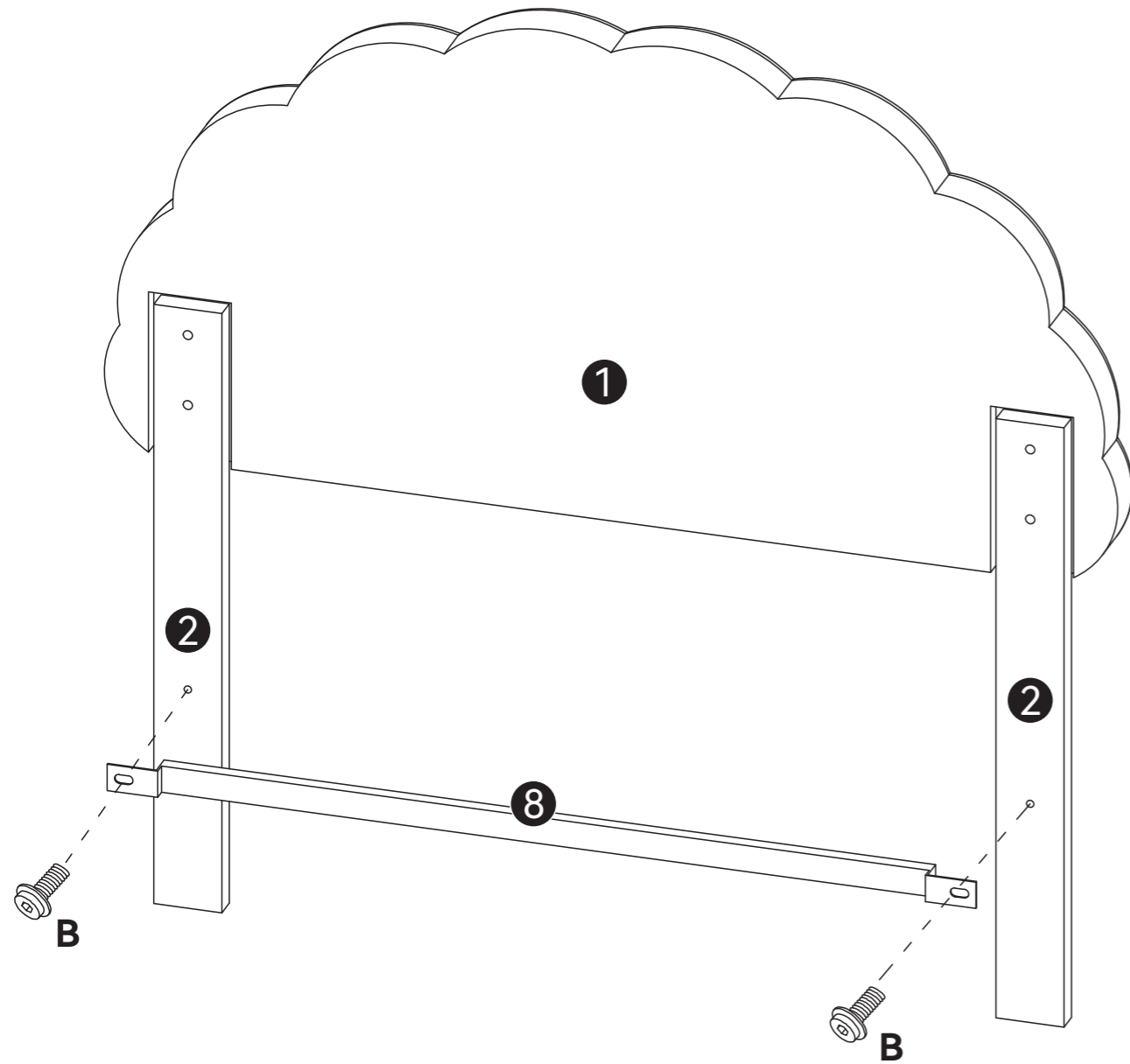
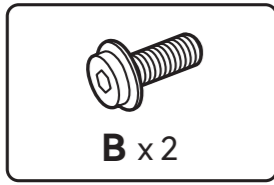

3

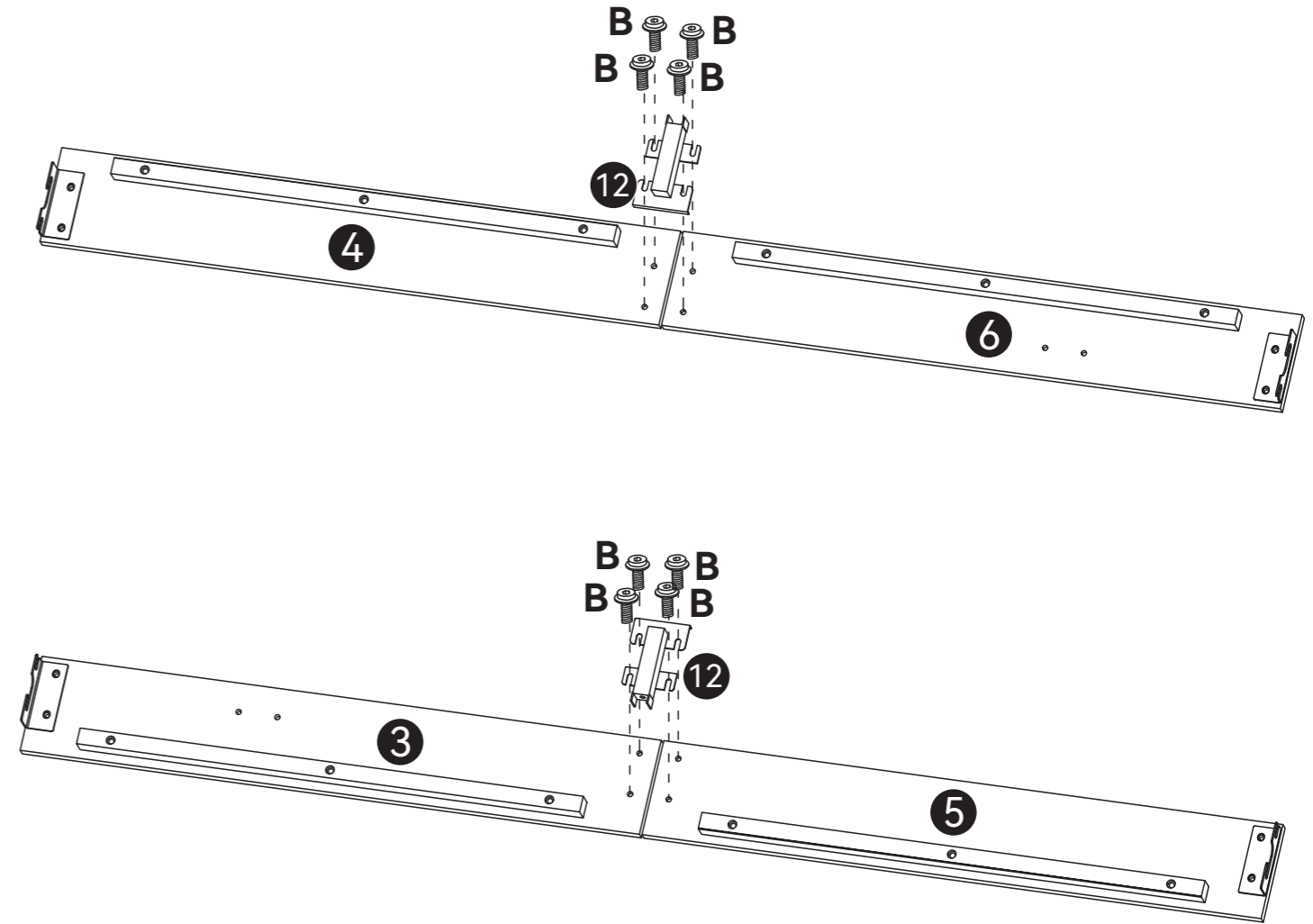
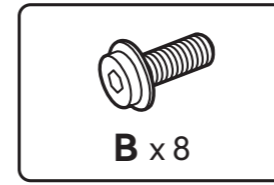

4

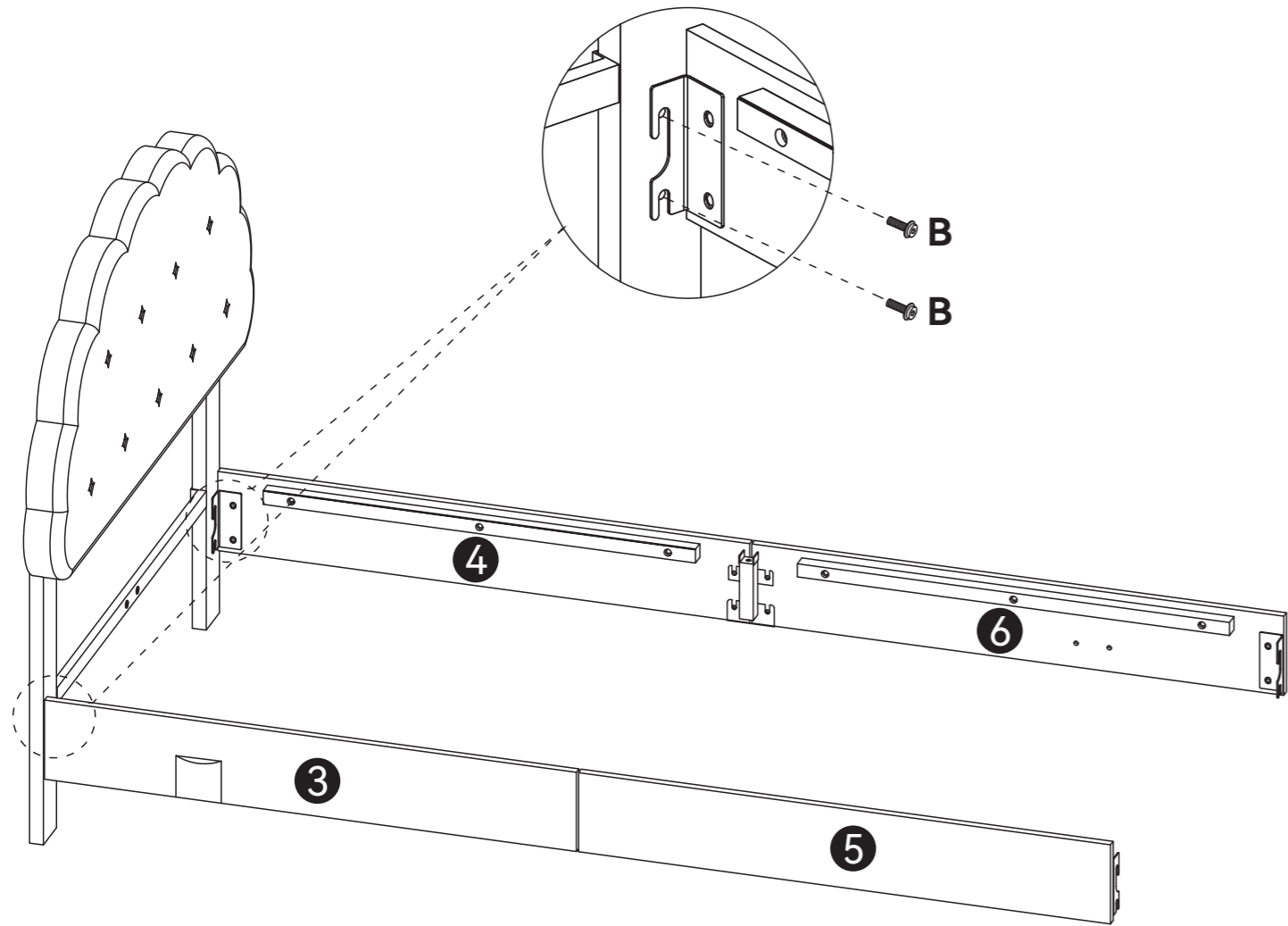
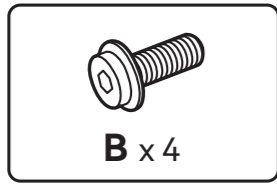

5

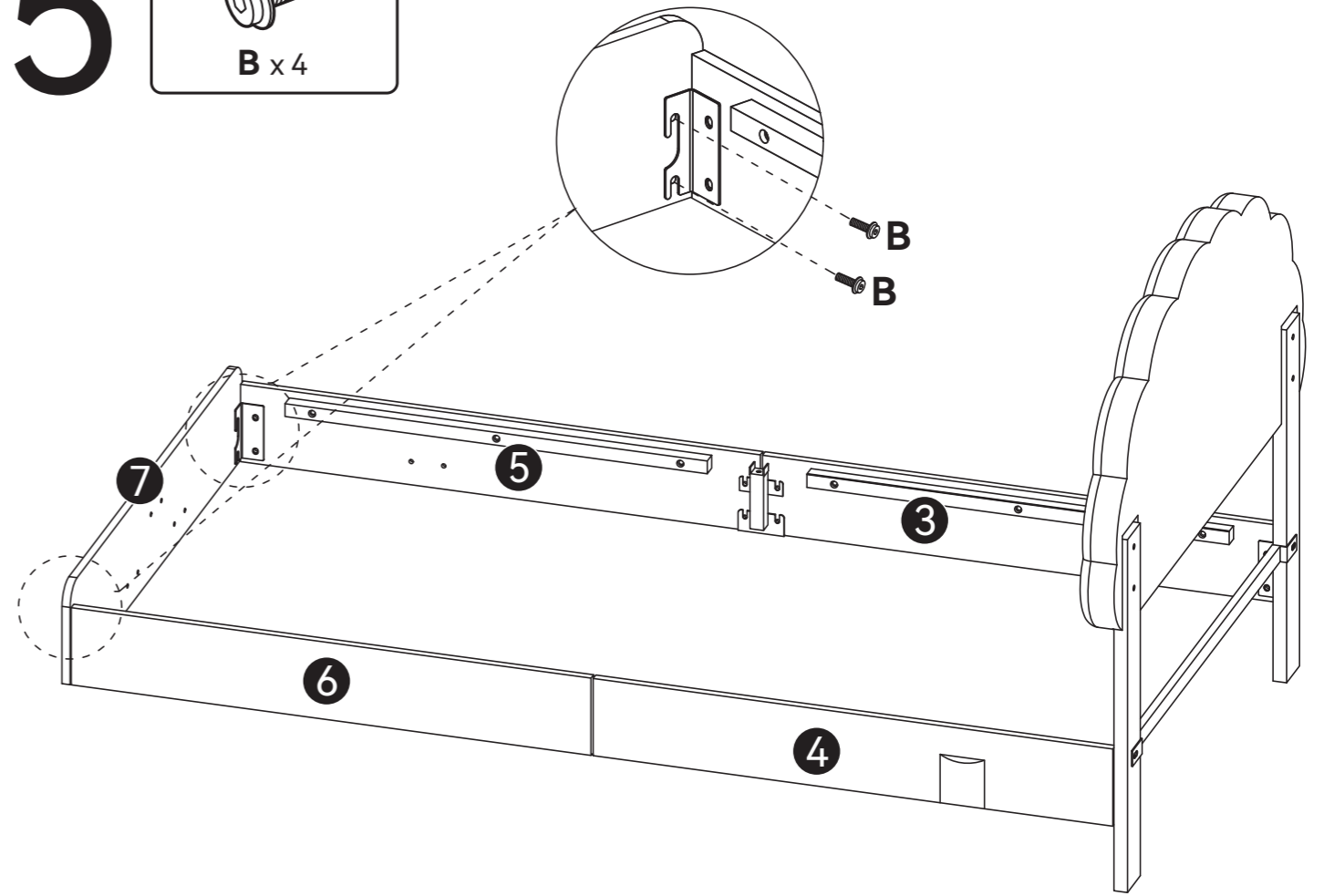
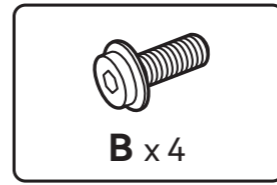

6

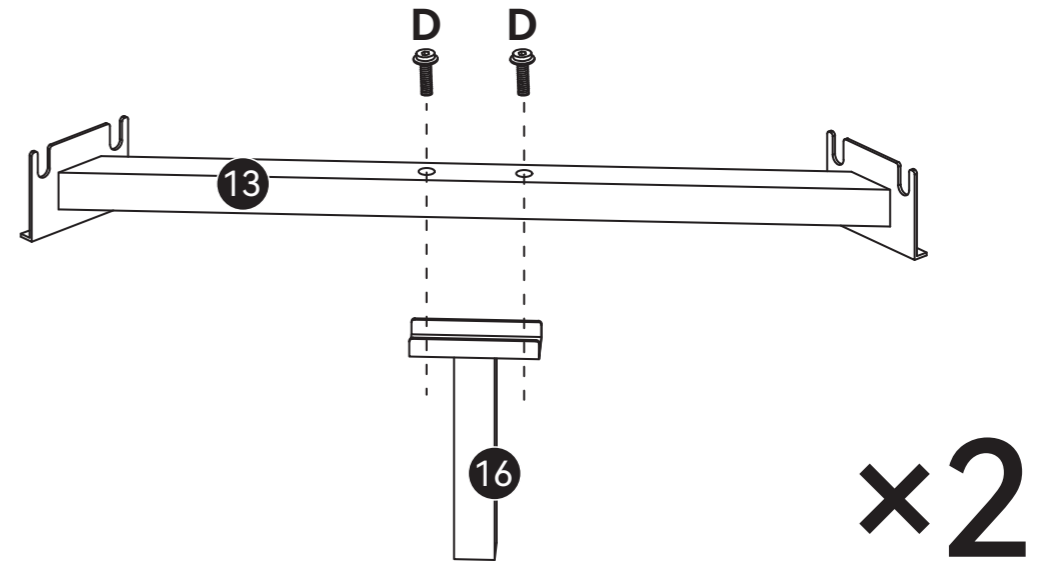
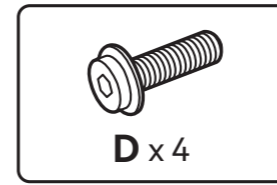

7

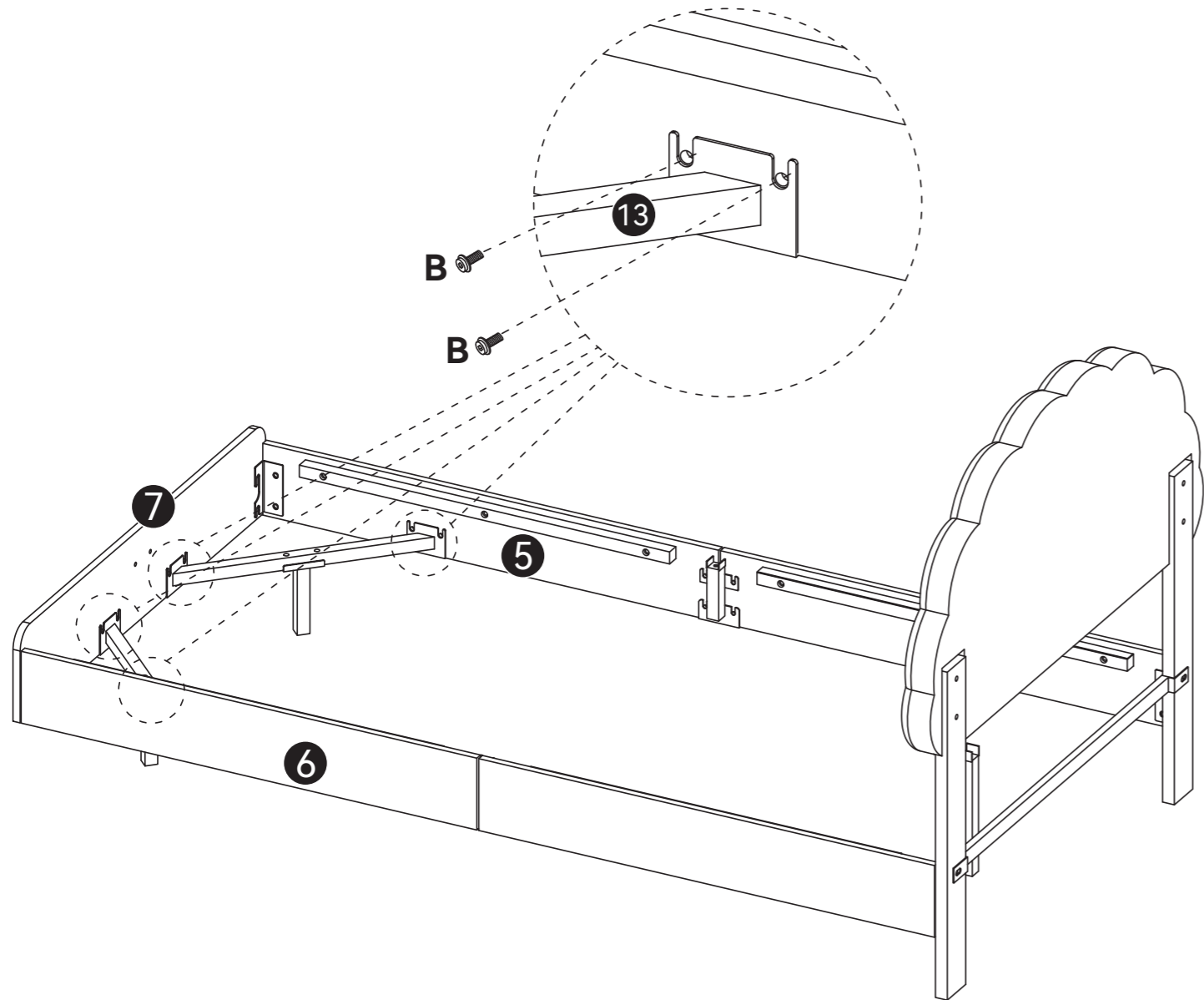
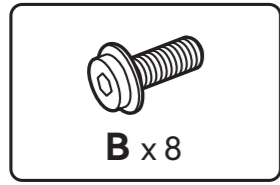

8

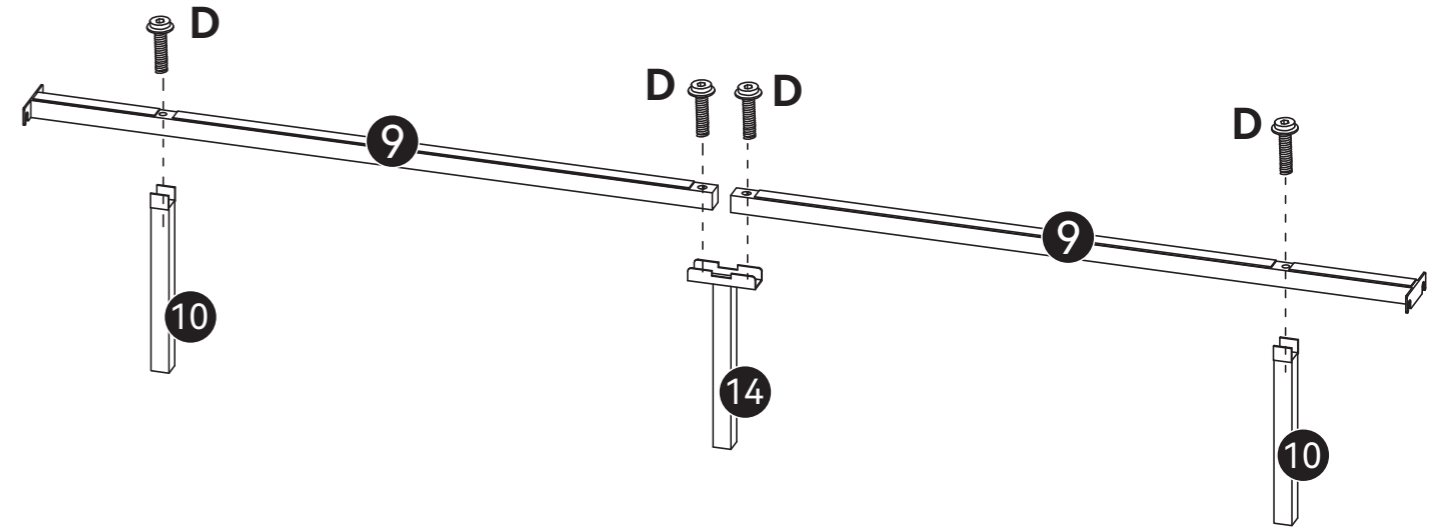
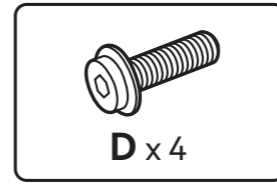

9

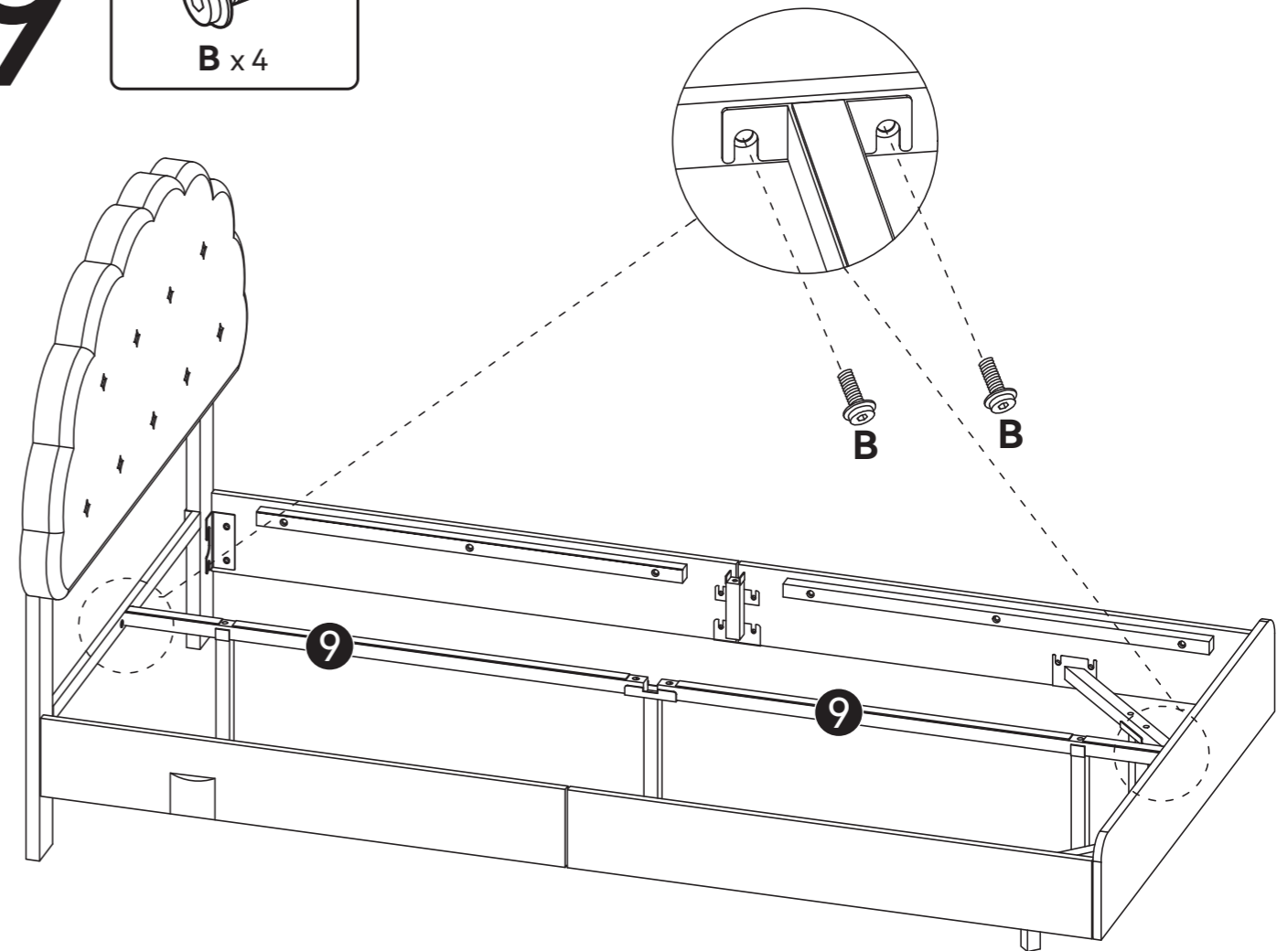
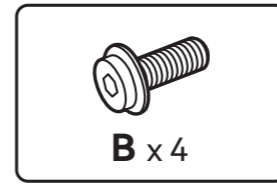

10

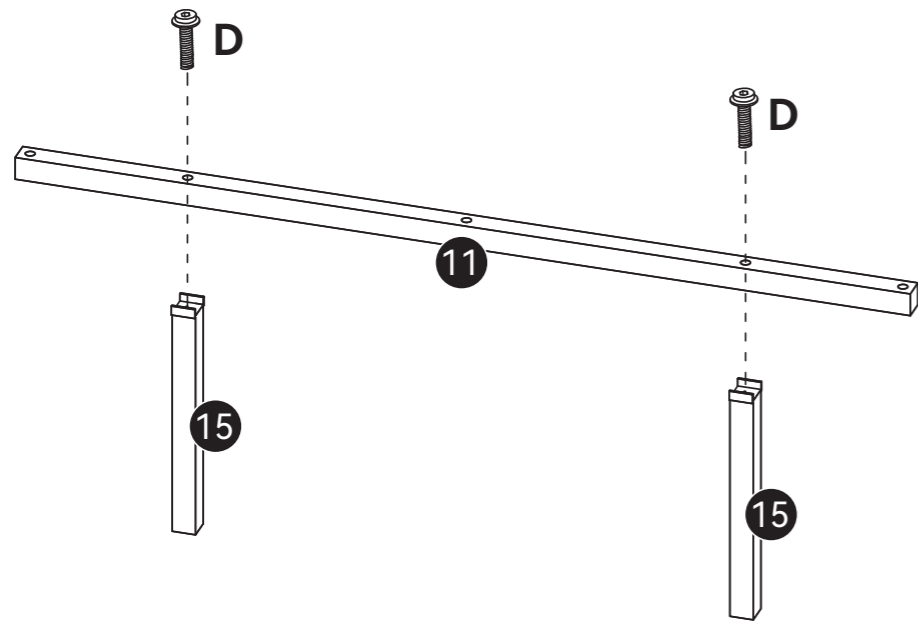
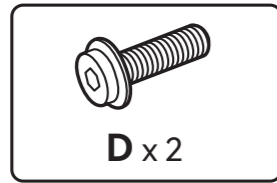

11

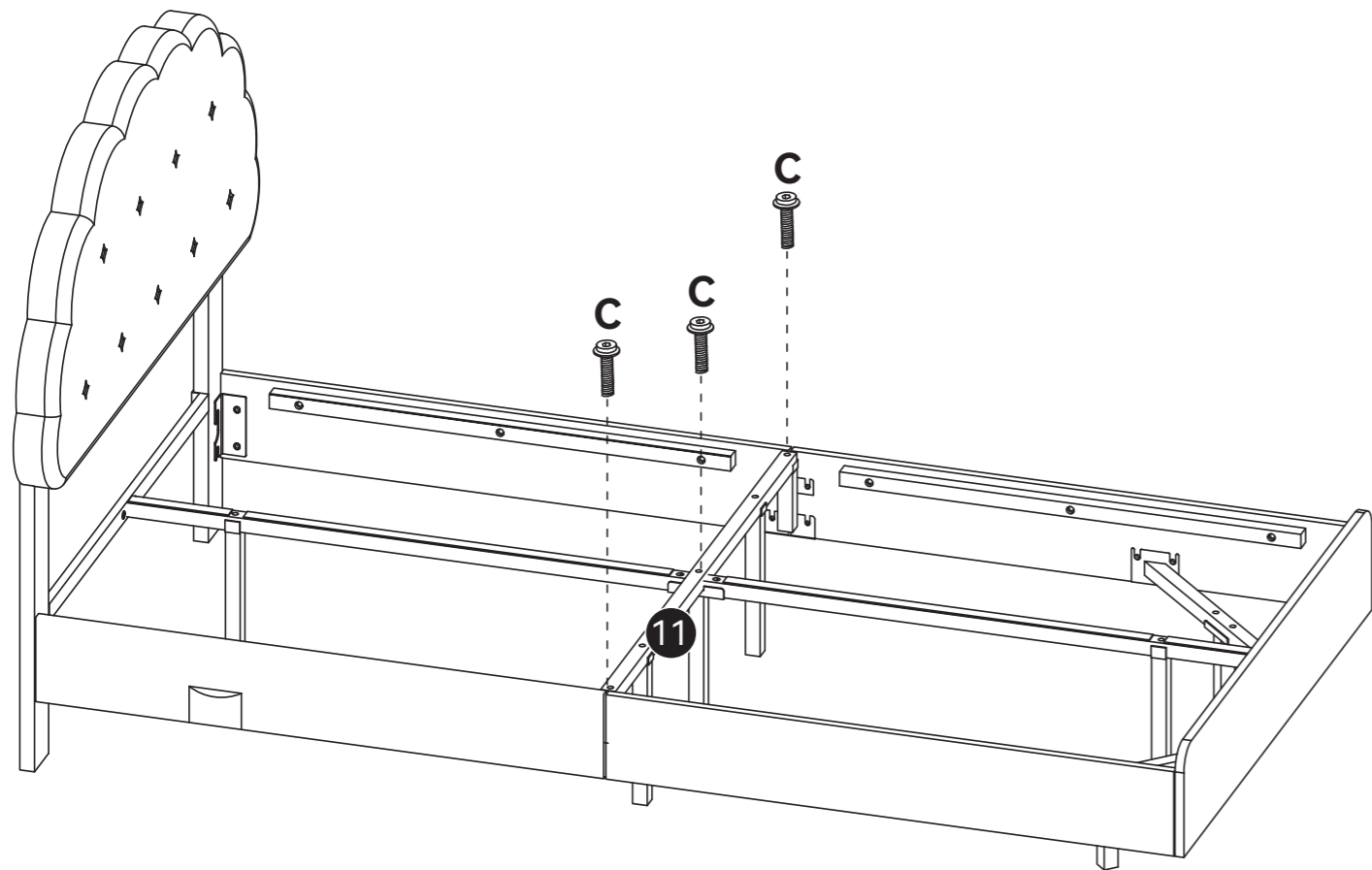
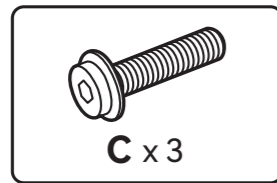

12

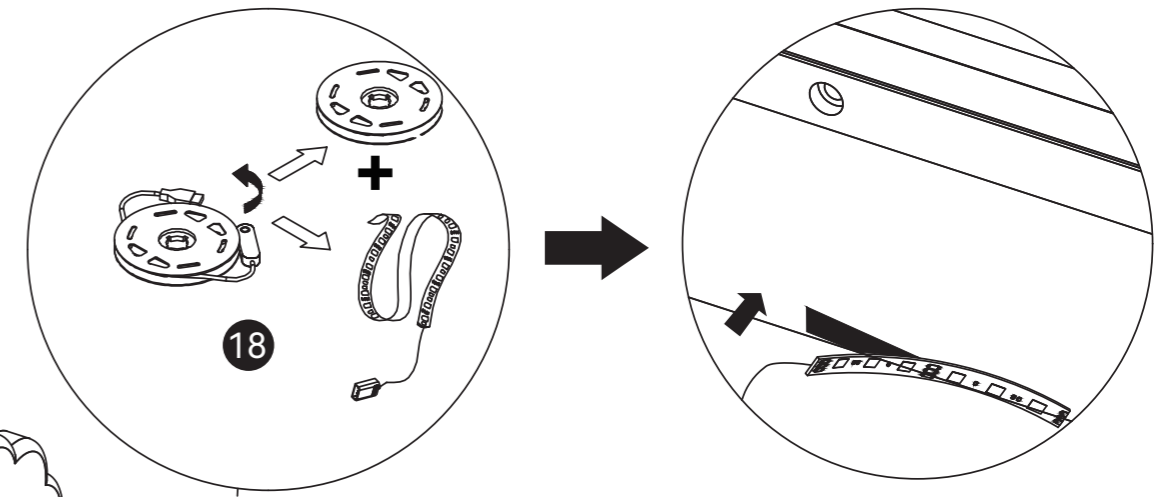
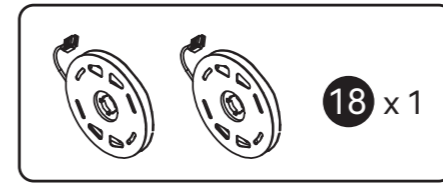

Attach the LED strip light to the side of the bed frame, following the directional arrow as illustrated.

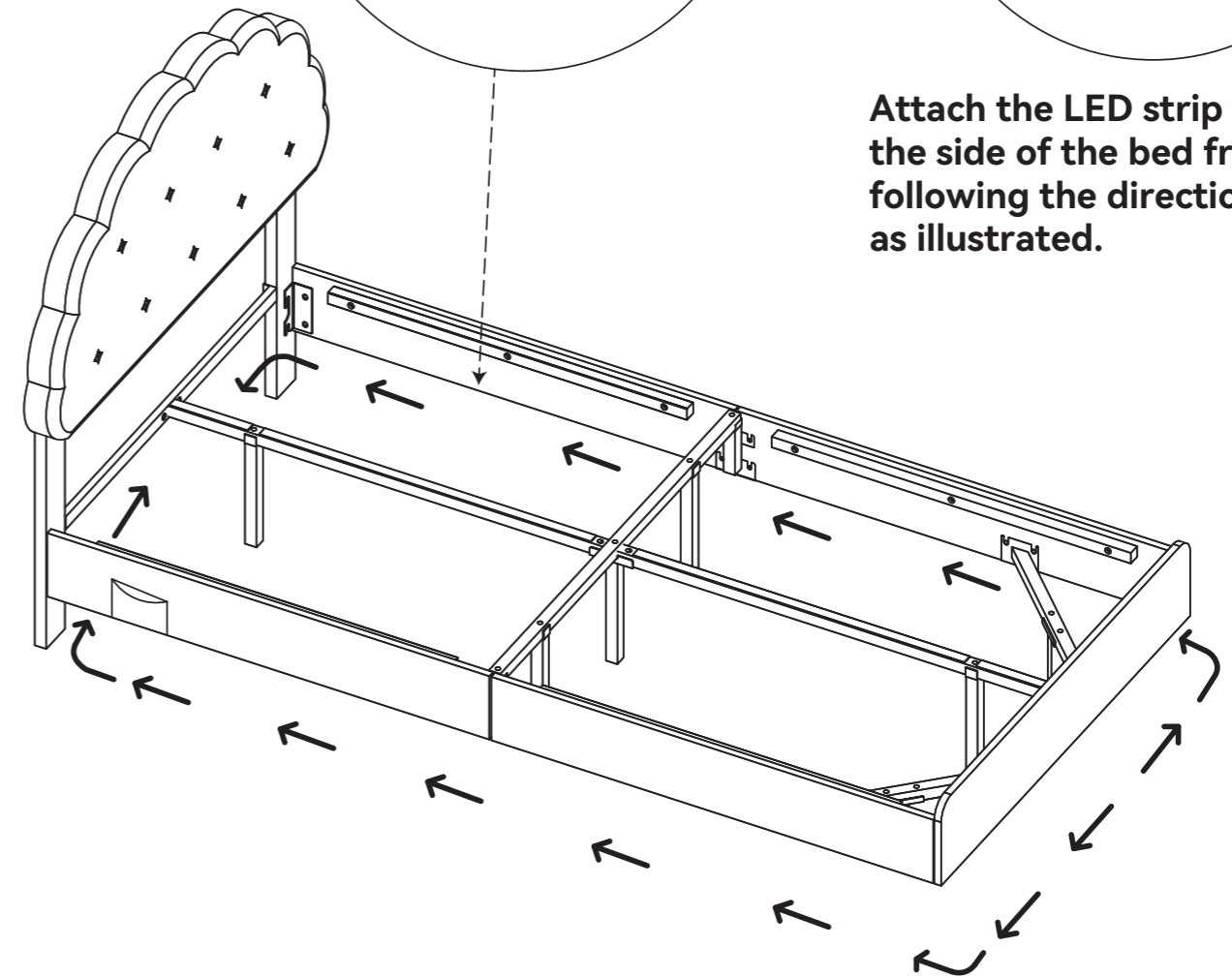

13

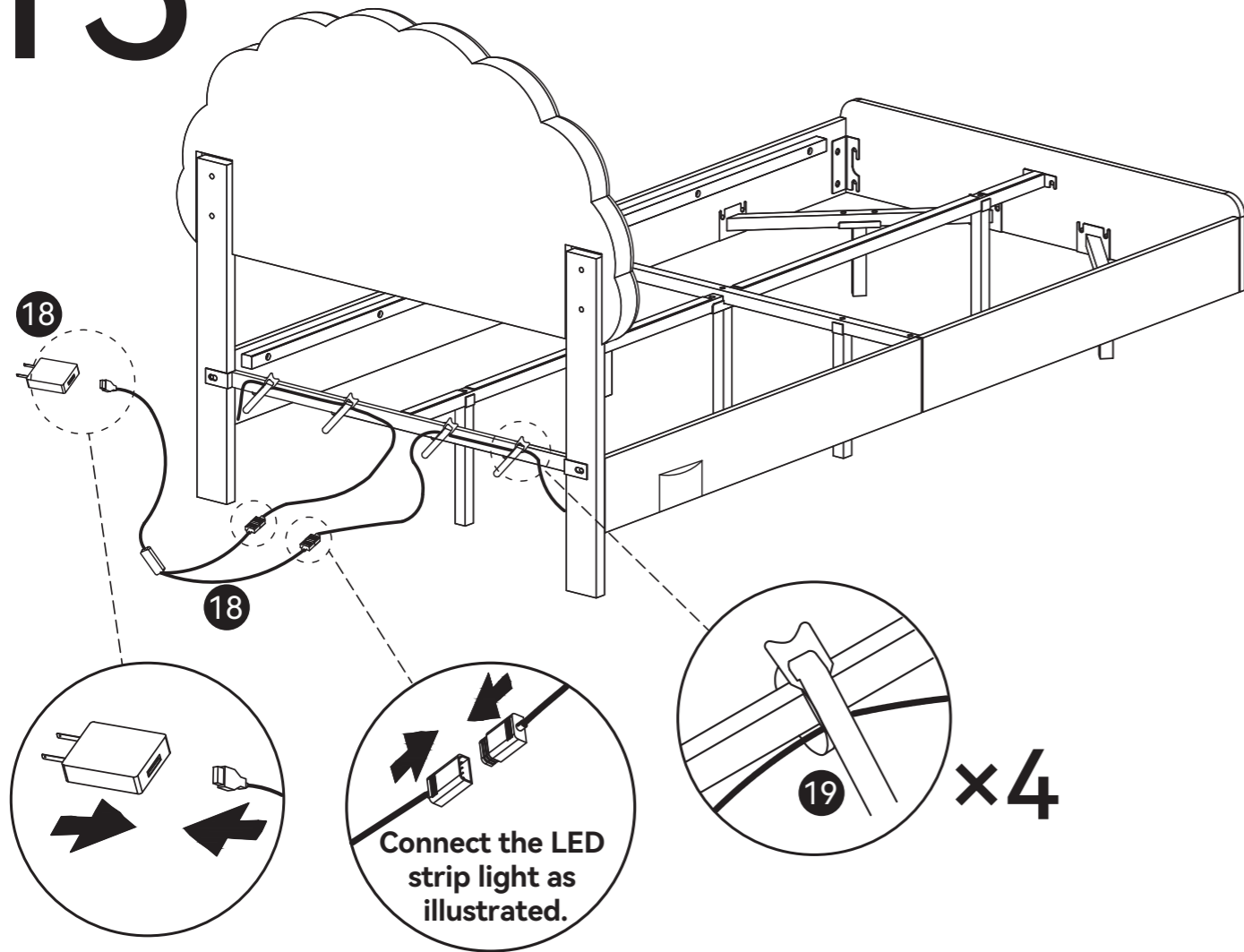

14

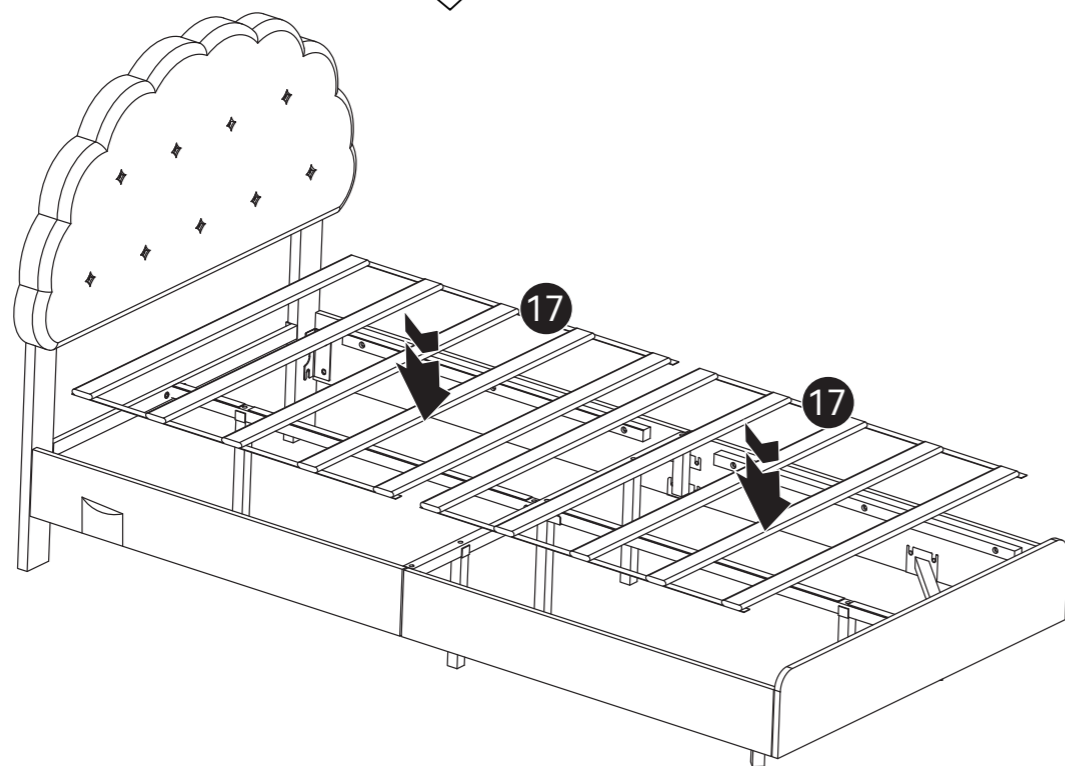

Using with Remote Control

Remove the plastic tab underneath battery before use.

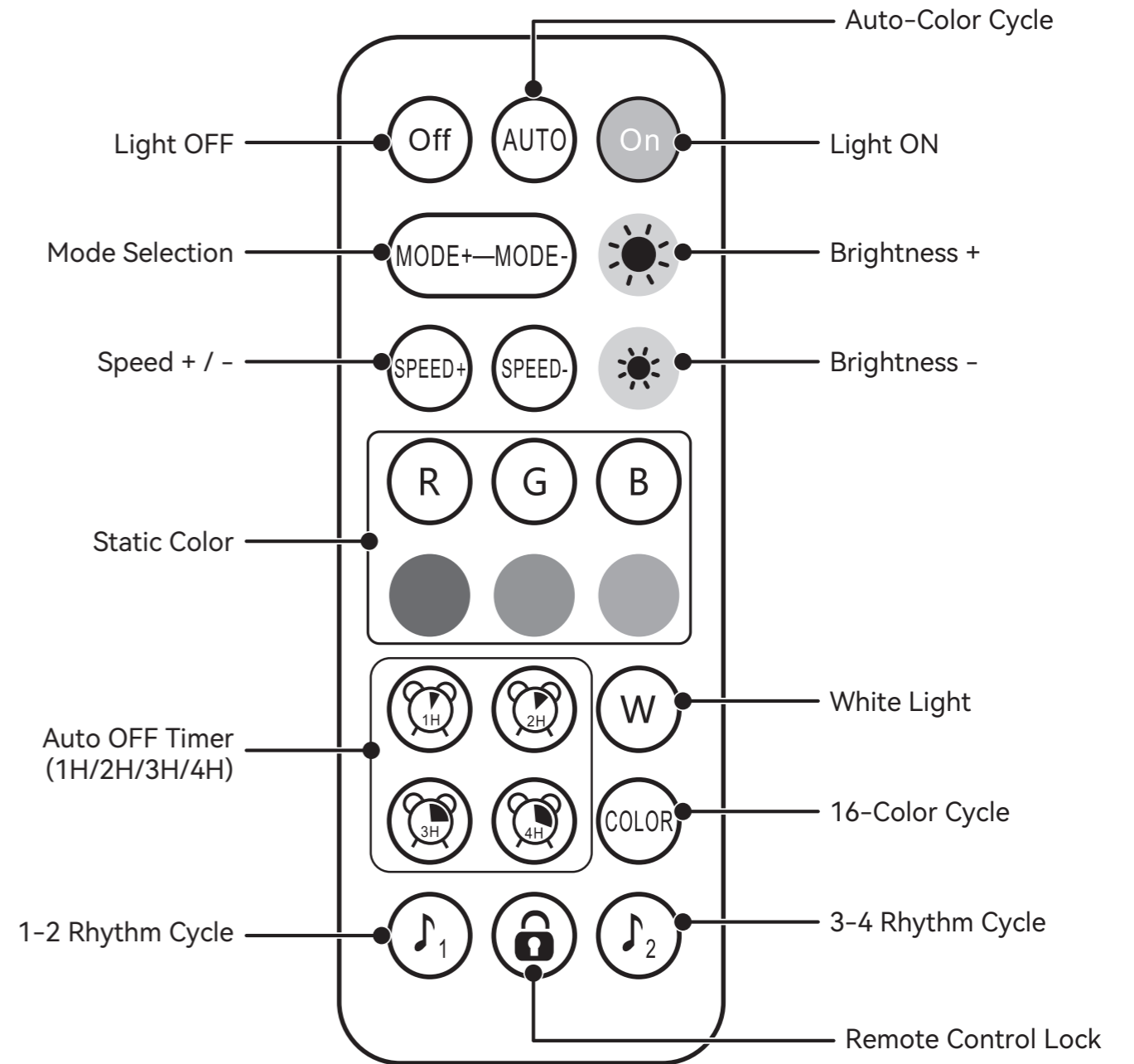

WARNING

- **INGESTION HAZARD:** This product contains a button cell or coin battery.
- **DEATH** or serious injury can occur if ingested.
- A swallowed button cell or coin battery can cause **Internal Chemical Burns** in as little as **2 hours**.
- **KEEP** new and used batteries **OUT OF REACH OF CHILDREN**.
- **Seek immediate medical attention** if a battery is suspected to be swallowed or inserted inside any part of the body.



Replacing Battery

- Replace with new battery of the same type (CR2025, 3V) when necessary.
- When not using the remote control for an extended period of time, take out the battery.

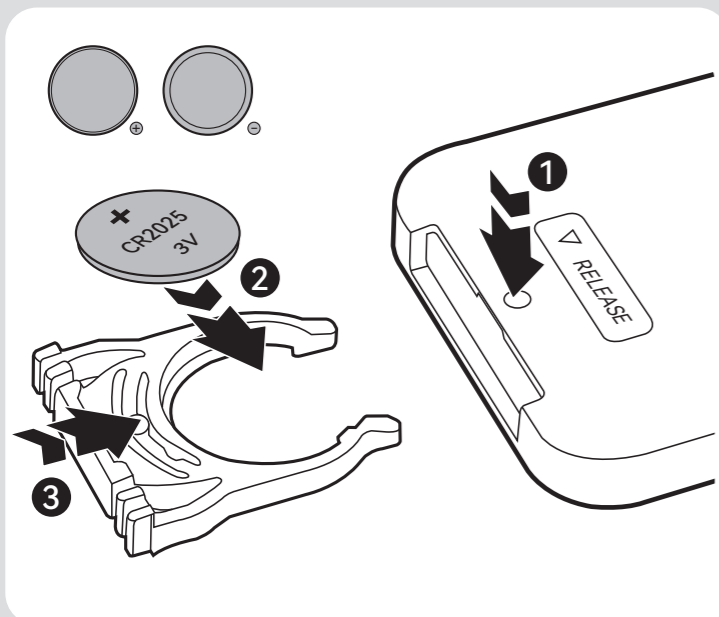

- 1 Press with an eject pin. Pinch the locking tab in then hold to pull the battery compartment cover out.
- 2 Replace the battery with the same type, making sure the (+) side facing up.
- 3 Install the cover back in place.

FCC Compliance

This device complies with Part 15 of the FCC Rules. Operation is subject to the following two conditions:
(1) this device may not cause harmful interference, and
(2) this device must accept any interference received, including interference that may cause undesired operation.

Warning: Changes or modifications not expressly approved by the party responsible for compliance could void the user's authority to operate the equipment.

NOTE: This equipment has been tested and found to comply with the limits for a Class B digital device, pursuant to Part 15 of the FCC Rules. These limits are designed to provide reasonable protection against harmful interference in a residential installation. This equipment generates uses and can radiate radio frequency energy and, if not installed and used in accordance with the instructions, may cause harmful interference to radio communications. However, there is no guarantee that interference will not occur in a particular installation. If this equipment does cause harmful interference to radio or television reception, which can be determined by turning the equipment off and on, the user is encouraged to try to correct the interference by one or more of the following measures:

- Reorient or relocate the receiving antenna.
- Increase the separation between the equipment and receiver.
- Connect the equipment into an outlet on a circuit different from that to which the receiver is connected.
- Consult the dealer or an experienced radio/TV technician for help.

FCC Radiation Exposure Statement

This equipment complies with FCC radiation exposure limits set forth for an uncontrolled environment. This equipment should be installed and operated with minimum distance 20cm between the radiator & your body.

- Remove and immediately recycle or dispose of used batteries according to local regulations and keep away from children. DO NOT dispose of batteries in household trash or incinerate.
- Even used batteries may cause severe injury or death.
- Call a local poison control center for treatment information.
- Use or replace with new battery of the same type (CR2025, 3V).
- Non-rechargeable batteries are not to be recharged.
- DO NOT force discharge, recharge, disassemble, heat above 140°F/60°C or incinerate. Doing so may result in injury due to venting, leakage or explosion resulting in chemical burns.
- Ensure the batteries are installed correctly according to polarity (+ and -).
- DO NOT mix old and new batteries, different brands or types of batteries, such as alkaline, carbon-zinc, or rechargeable batteries.
- Remove and immediately recycle or dispose of batteries from equipment not used for an extended period of time according to local regulations.
- Always completely secure the battery compartment. If the battery compartment does not close securely, stop using the product, remove the batteries, and keep them away from children.