



**Chintaly Imports**

ASSEMBLY INSTRUCTIONS

ITEM NO: 8097-CT

THANK YOU FOR PURCHASING THIS QUALITY PRODUCT. BE SURE TO CHECK ALL PACKING MATERIAL CAREFULLY FOR SMALL PARTS THAT MAY HAVE COME LOOSE INSIDE THE CARTON DURING TRANSIT.

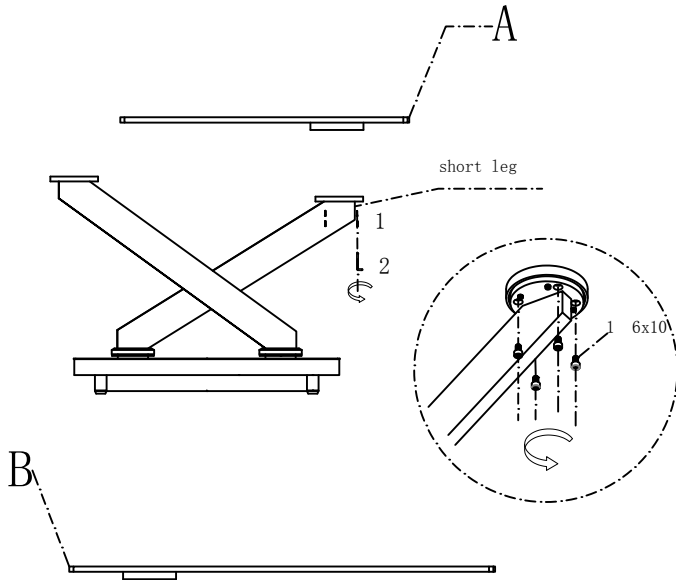

### Part List

NO	DESC	SIZE (MM)	SKETCH	QTY
A	Top	770x542		1PC
B	Extension	800x800		1PC
C	Base	600x600		1PC

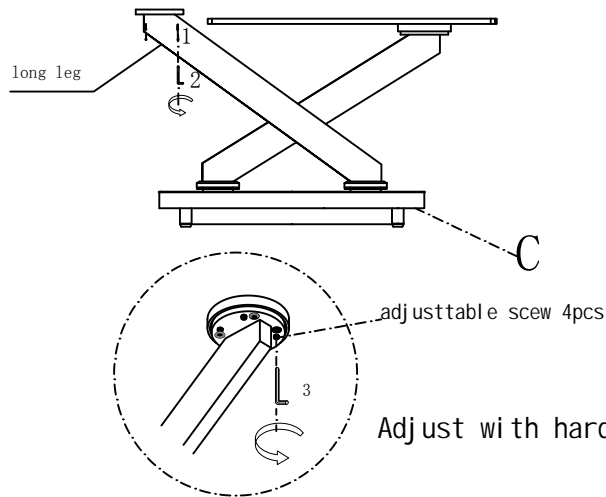

### Hardware List

NO	DESC	SIZE (MM)	SKTCH	QTY
1		6x10		8pcs
2	5# Allen key			1pcs
3	3# Allen key			1pcs

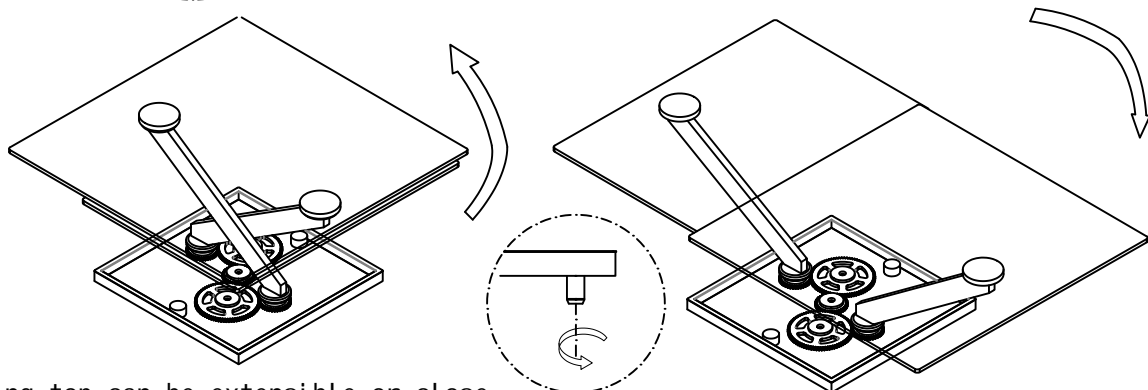

The rotating top can be extensible or close

Please adjust the adjustable glides if needed

MADE IN CHINA