

Installation sanleitung
Installation Instruction
Instruction d'installation

bett 140x200

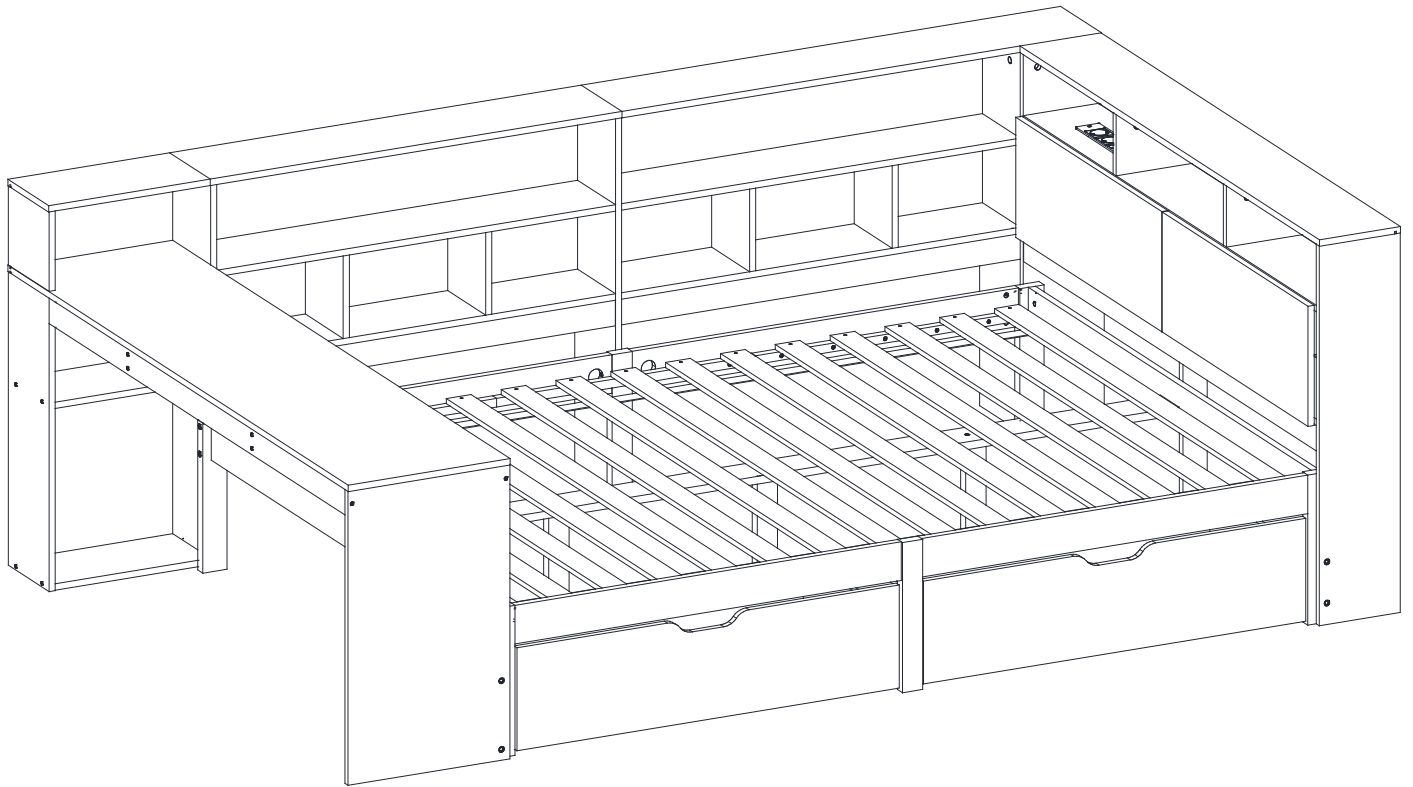

DE: Unser Produkt wird Ihnen in 4 Paketen geliefert. Die Lieferzeiten dieser 4 Pakete können abweichen, bitte haben Sie etwas Geduld und vielen Dank für Ihr Verständnis.

UK: Our product will be delivered to you in 4 packages. The delivery times of these 4 packages may differ, please be patient and thank you for your understanding.

FR: Notre produit vous sera livré en 4 colis. Les délais de livraison de ces 4 colis peuvent différer, soyez patient et merci pour votre compréhension.



N879P305737/N879P305738/N879P305739/N879P305740

INSTRUCTIONS

IMPORTANT-READ CAREFULLY-RETAIN FOR FUTURE REFERENCE

- a) **WARNING** -Children can become trapped between the bed and the wall, the adjoining pieces of furniture (e.g. cupboards) and the like. To avoid risk of serious injury the distance between the safety barrier and the adjoining structure shall not exceed 75 mm or shall be more than 230 mm.
- b) **WARNING**-Do not use the bed if any structural part is broken or missing; Replacement parts are between requested from the manufacturer or the store.
- c) **WARNING**-Do not climb or wiggle on any non-designated structures.
- d) it is imperative to always follow the installation instructions and manufacturer's use.
- e) **The recommended size of the mattress to be used with the bed is 200cmx140cm, maximum thickness mattress:12cm.**
- f) It is necessary to ventilate the room in order to maintain a low level moisture and prevent mold growth in the bed and its periphery.
- g) Joining devices should always be tightened properly and regularly verified. Tighten if necessary.

ANLEITUNGEN

WICHTIG - SORGFÄLTIG LESEN - FÜR SPÄTERE VERWENDUNG

AUFBEWAHREN

- a) **WARNUNG** - Kinder können zwischen dem Bett und der Wand, den angrenzenden Möbelstücken (z. B. Schränken) und der Lücke eingeklemmt werden. Um die Gefahr schwerer Verletzungen zu vermeiden, darf der Abstand zwischen der Sicherheitsbarriere und der angrenzenden Struktur nicht mehr als 75 mm oder mehr als 230 mm betragen.
- b) **WARNUNG**-Das Bett darf nicht benutzt werden, wenn ein Bauteil gebrochen ist oder fehlt; Ersatzteile sind beim Hersteller oder im Geschäft anzufordern.
- c) **WARNUNG** - Klettern oder wackeln Sie nicht auf nicht dafür vorgesehenen Strukturen.
- d) Befolgen Sie unbedingt die Installationsanweisungen und die Gebrauchsanweisungen des Herstellers.
- e) **Die empfohlene Größe der Matratze für das Bett beträgt 200x140cm, maximale Dicke der Matratze: 12cm.**
- f) Es ist notwendig, den Raum zu lüften, um die Feuchtigkeit niedrig zu halten und Schimmelbildung im Bett und seiner Umgebung zu verhindern.
- g) Die Verbindungselemente sollten immer richtig angezogen sein und regelmäßig überprüft werden. Ziehen Sie sie gegebenenfalls nach.

English

IMPORTANT ! KEEP FOR FUTURE REFERENCE : READ CAREFULLY

- To be assembled by an adult. Assembly must be checked by an adult before use
 - WARNING ! Keep all screws, small parts and plastic bags out of the reach of children
 - Properly identify all parts before assembling
 - Never use your item if any of its parts are broken or missing
 - Should any problems arise, please contact our After Sales Service
 - Manufacturer's instructions shall be followed at all times
 - Care: Clean with a soft, dry cloth. In case of larger stains, carefully rub with a slightly damp, non-abrasive sponge
 - Avoid the risk of fire by not placing furniture near sources of ignition or hot items
- Do not jump on the bed

Deutsch

WICHTIG ! ZUM SPÄTEREN NACHSCHLAGEN AUFBEWAHREN: SORGFÄLTIG LESEN

- Muss von einem Erwachsenen zusammengebaut werden. Der Zusammenbau muss vor dem Gebrauch von einem Erwachsenen überprüft werden
 - WARNUNG! Bewahren Sie alle Schrauben, Kleinteile und Plastikbeutel außerhalb der Reichweite von Kindern auf
 - Kennzeichnen Sie vor dem Zusammenbau alle Teile richtig
 - Benutzen Sie Ihren Artikel niemals, wenn Teile gebrochen sind oder fehlen
 - Sollten Probleme auftreten, wenden Sie sich bitte an unseren Kundendienst
 - Die Anweisungen des Herstellers sind stets zu befolgen
 - Pflege: Mit einem weichen, trockenen Tuch reinigen. Bei größeren Flecken vorsichtig mit einem leicht feuchten, nicht scheuernden Schwamm abreiben. nicht scheuernden Schwamm
 - Vermeiden Sie die Gefahr eines Brandes, indem Sie die Möbel nicht in der Nähe von Zündquellen oder heißen Gegenständen aufstellen
- Nicht auf das Bett springen

Français

IMPORTANT ! CONSERVER POUR RÉFÉRENCE ULTÉRIEURE : LIRE ATTENTIVEMENT

- Le montage doit être effectué par un adulte. Le montage doit être vérifié par un adulte avant Utilisation
 - ATTENTION ! Tenir les vis, les petites pièces et les sachets en plastique hors de portée des enfants
 - Identifiez correctement toutes les pièces avant de les assembler
 - N'utilisez jamais votre article si l'une de ses pièces est cassée ou manquante
 - En cas de problème, veuillez contacter notre service après-vente
 - Les instructions du fabricant doivent être respectées à tout moment
 - Entretien : nettoyer avec un chiffon doux et sec. En cas de taches plus importantes, frotter soigneusement avec une éponge non abrasive légèrement humide. légèrement humide et non Abrasive
 - Évitez les risques d'incendie en ne plaçant pas les meubles à proximité de sources d'inflammation ou d'objets chauds
- Ne pas sauter sur le lit

Italiano

IMPORTANTE! CONSERVARE PER RIFERIMENTO FUTURO: LEGGERE ATTENTAMENTE

- Deve essere assemblato da un adulto. L'assemblaggio deve essere controllato da un adulto prima dell'uso
- **ATTENZIONE!** Tenere tutte le viti, le piccole parti e i sacchetti di plastica fuori dalla portata dei bambini
- Identificare correttamente tutte le parti prima dell'assemblaggio
- Non utilizzare mai l'articolo se alcune parti sono rotte o mancanti
- In caso di problemi, si prega di contattare il nostro Servizio Post Vendita
- Le istruzioni del produttore devono essere sempre seguite
- Cura: Pulire con un panno morbido e asciutto. In caso di macchie più estese, strofinare accuratamente con una spugna leggermente umida e nonspugna leggermente umida e non abrasiva
- Evitare il rischio di incendio, non collocando i mobili vicino a fonti di accensione o a oggetti caldi
- Non saltare sul letto

Español

¡ IMPORTANTE ! CONSERVELO PARA FUTURAS CONSULTAS: LEA ATENTAMENTE

- Debe ser montado por un adulto. El montaje debe ser comprobado por un adulto antes del uso
- **ADVERTENCIA** Mantenga todos los tornillos, piezas pequeñas y bolsas de plástico fuera del alcance de los niños.
- Identifique correctamente todas las piezas antes de montarlas
- Nunca utilice su artículo si alguna de sus piezas está rota o falta
- Si surge algún problema, póngase en contacto con nuestro Servicio Postventa
- Las instrucciones del fabricante deben seguirse en todo momento
- Cuidado: Limpiar con un paño suave y seco. En caso de manchas más grandes, frote cuidadosamente con una esponja no abrasiva ligeramente humedecida.
- Evite el riesgo de incendio no colocando los muebles cerca de fuentes de ignición u objetos calientes.
- No saltar sobre la cama.

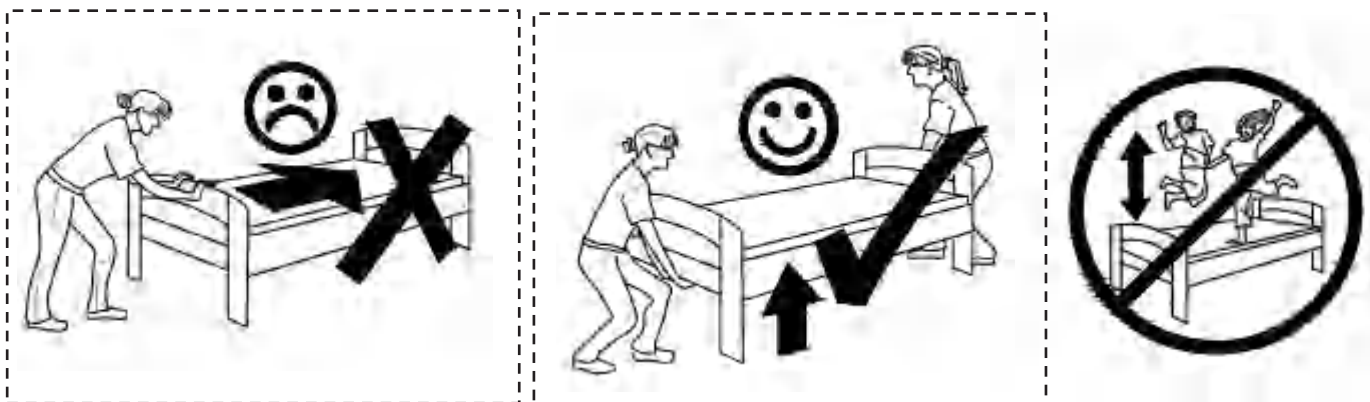

English

IMPORTANT ! KEEP FOR FUTURE REFERENCE : READ CAREFULLY

- To be assembled by an adult. Assembly must be checked by an adult before use.
- **WARNING !** Keep all screws, small parts and plastic bags out of the reach of children.
- Properly identify all parts before assembling.
- Anchor unit to stud or wall.
- Always use on a level, even surface.
- Avoid the risk of fire by not placing furniture near sources of ignition or hot items.
- **DO NOT** place hot or cold items directly onto the surface.
- **DO NOT** place the item next to a radiator or direct sunlight.
- **DO NOT** allow children to climb on unit.
- **DO NOT** put the product in a humid environment.

Deutsch

WICHTIG ! ZUM SPÄTEREN NACHSCHLAGEN AUFBEWAHREN: SORGFÄLTIG LESEN

- Muss von einem Erwachsenen zusammengebaut werden. Der Zusammenbau muss vor der Benutzung von einem Erwachsenen überprüft werden.
- **WARNUNG!** Bewahren Sie alle Schrauben, Kleinteile und Plastikbeutel außerhalb der Reichweite von Kindern auf.
- Kennzeichnen Sie vor dem Zusammenbau alle Teile ordnungsgemäß.
- Verankern Sie das Gerät an einem Ständer oder einer Wand.
- Benutzen Sie das Gerät immer auf einer ebenen, geraden Fläche.
- Vermeiden Sie das Risiko eines Brandes, indem Sie die Möbel nicht in der Nähe von Zündquellen oder heißen Gegenständen aufstellen.
- Stellen Sie **KEINE** heißen oder kalten Gegenstände direkt auf die Oberfläche.
- Stellen Sie das Gerät **NICHT** in der Nähe eines Heizkörpers oder direkter Sonneneinstrahlung auf.
- Erlauben Sie Kindern **NICHT**, auf das Gerät zu klettern.
- Stellen Sie das Gerät **NICHT** in einer feuchten Umgebung auf.

Français

IMPORTANT ! CONSERVER POUR RÉFÉRENCE ULTÉRIEURE : LIRE ATTENTIVEMENT

- A assembler par un adulte. Le montage doit être vérifié par un adulte avant utilisation.
- **ATTENTION !** Conservez toutes les vis, les petites pièces et les sacs en plastique hors de portée des enfants.
- Identifiez correctement toutes les pièces avant de les assembler.
- Fixer l'appareil à un montant ou à un mur.
- Utilisez toujours l'appareil sur une surface plane et uniforme.
- Évitez les risques d'incendie en ne plaçant pas les meubles à proximité de sources d'inflammation ou d'objets chauds.
- **NE PAS** placer d'objets chauds ou froids directement sur la surface.
- **NE PAS** placer l'appareil à côté d'un radiateur ou de la lumière directe du soleil.
- **NE PAS** laisser les enfants grimper sur l'appareil.
- **NE PAS** placer le produit dans un environnement humide.

Italiano

IMPORTANTE! CONSERVARE PER RIFERIMENTO FUTURO: LEGGERE ATTENTAMENTE

- Deve essere assemblato da un adulto. L'assemblaggio deve essere controllato da un adulto prima dell'uso.
- AVVERTENZA ! Tenere tutte le viti, le piccole parti e i sacchetti di plastica fuori dalla portata dei bambini.
- Identificare correttamente tutte le parti prima dell'assemblaggio.
- Ancorare l'unità a un pilastro o a una parete.
- Utilizzare sempre su una superficie piana e uniforme.
- Evitare il rischio di incendio non collocando i mobili vicino a fonti di accensione o ad oggetti caldi.
- NON collocare oggetti caldi o freddi direttamente sulla superficie.
- NON collocare l'apparecchio vicino a un termosifone o alla luce diretta del sole.
- NON permettere ai bambini di arrampicarsi sull'unità.
- NON collocare il prodotto in un ambiente umido.

Español

¡ IMPORTANTE ! CONSERVELO PARA FUTURAS CONSULTAS: LEA ATENTAMENTE

- Debe montarlo un adulto. El montaje debe ser comprobado por un adulto antes del uso.
- ADVERTENCIA Mantenga todos los tornillos, piezas pequeñas y bolsas de plástico fuera del alcance de los niños.
- Identifique correctamente todas las piezas antes del montaje.
- Ancle la unidad a un montante o pared.
- Utilí celo siempre sobre una superficie plana y nivelada.
- Evite el riesgo de incendio no colocando los muebles cerca de fuentes de ignición o artículos calientes.
- NO coloque objetos calientes o fríos directamente sobre la superficie.
- NO coloque el mueble cerca de un radiador o de la luz solar directa.
- NO permita que los niños se suban a la unidad.
- NO coloque el producto en un ambiente húmedo.

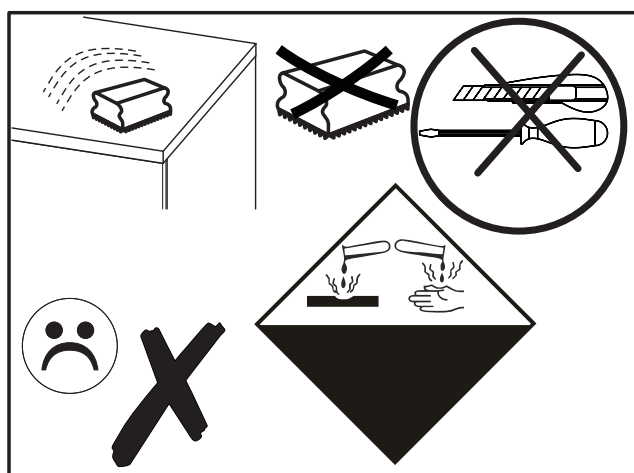

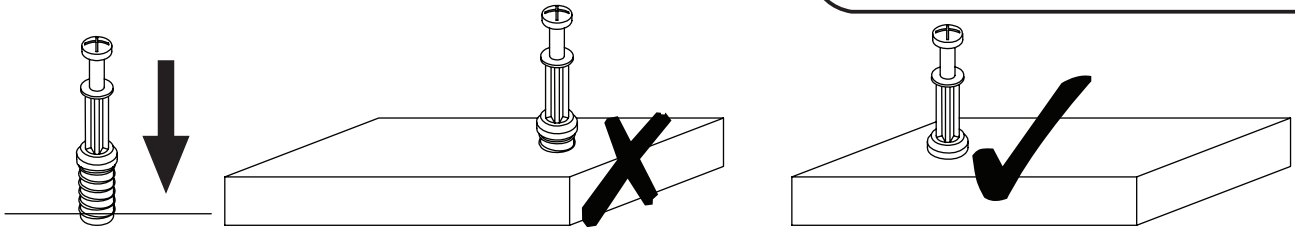

EN_QUICKFIT: Tighten quickfit until shoulder is flush with panel. Do not overtighten or undertighten.

FR_RACCORD RAPIDE: Faites serrer le raccord rapide jusqu'à ce que l'épaule soit parfaitement encastré dans le panneau. Il ne faut ni trop serrer ni insuffisamment serrer.

ES_QUICKFIT: Apriete quickfit hasta que el hombro se descargue con el panel. NO lo sobreapriete ni lo apriete poco.

DE_QUICKFIT: Ziehen Sie den Quickfit fest, bis die Schulter mit der Platte bündig ist. Bitte nicht zu fest oder zu schwach anziehen.

IT_MONTAGGIO RAPIDO: Stringere il montaggio rapido fino a quando la spalla è a filo con il pannello, non stringere troppo o troppo poco.

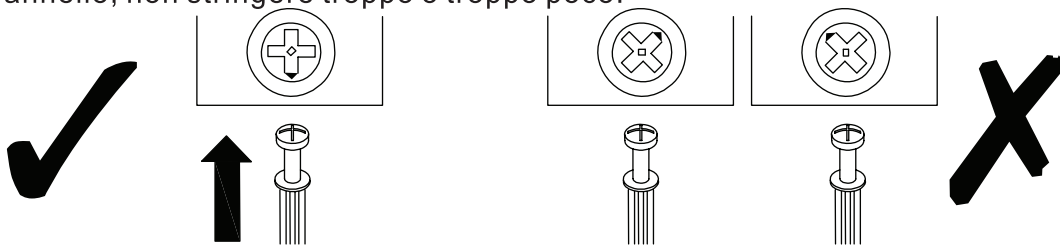

EN_CAM LOCK: When fitting cam lock, ensure starting position is correct before you insert connecting quickfit.

FR_SERRURE BATTEUSE: Avant d'insérer la serrure batteuse, veillez à la bonne orientation avant d'insérer le raccord rapide.

ES_CIERRE DE LA CÁMARA: Cuando instale el cierre de la cámara, asegúrese de que la posición de inicio es correcta antes de que inserte el quickfit conector.

DE_CAM-LOCK: Achten Sie bei der Montage des Cam-Locks auf die richtige Ausgangsposition, bevor Sie den Quickfit einsetzen.

IT_BLOCCAGGIO A CAMMA: Quando si monta il bloccaggio a camma, assicurarsi che la posizione iniziale sia corretta prima di inserire il montaggio rapido di collegamento.

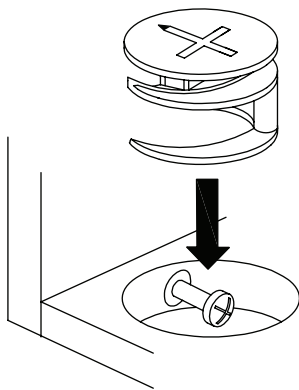

EN_Quickfit head should be in the centre of the cam lock when the two panels are joined.

Cam lock should be inserted before quickfit.

FR_Lorsque les deux panneaux sont assemblés, la tête du raccord rapide doit reposer au centre de la serrure batteuse. Il faut insérer la serrure batteuse avant le raccord rapide.

ES_El cabezal del quickfit debe estar en el centro del cierre de la cámara cuando se unan los dos paneles.

Se debe insertar el cierre de la cámara antes que el quickfit.

DE_Der Quickfit-Kopf sollte sich in der Mitte des Cam-Locks befinden, wenn die beiden Platten zusammengefügt sind.

Der Cam-Lock sollte vor dem Quickfit eingesetzt werden.

IT_La testa del montaggio rapido deve trovarsi al centro del bloccaggio a camma quando i due pannelli sono uniti.

Il Bloccaggio a Camma deve essere inserito prima del montaggio rapido.

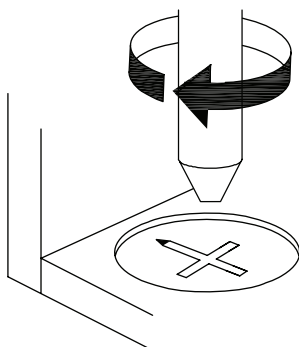

EN_Turn cam lock clockwise to tighten.

FR_Faites tourner la serrure batteuse dans le sens des aiguilles d'une montre pour la resserrer.

ES_Gire el cierre de la cámara en sentido horario para apretarlo.

DE_Drehen Sie den Cam-Lock im Uhrzeigersinn, um ihn festzuziehen.

IT_Ruotare il bloccaggio a camma in senso orario per stringere.

DE: Vor dem Einbau die Schrauben in die Löcher stecken und festziehen, aber nicht bis 100%, 70% bis 80% anziehen reicht aus. Schließlich, nachdem alle Schrauben installiert sind, ziehen Sie alle Schrauben auf 100%. Wenn Sie auf diese Probleme stoßen, wie z. B. Fehlausrichtung der Löcher oder Unfähigkeit, bestimmte Teile zu installieren, überprüfen Sie bitte, ob die Schrauben korrekt verwendet werden und passen Sie die Dichtigkeit der Schrauben an.

UK: Before installation, insert the screws into the holes and tighten them, but do not tighten them to 100%, 70% to 80% is sufficient. Finally, after all screws are installed, tighten all screws to 100%. If you encounter these issues, such as if the holes cannot be aligned or some parts cannot be installed, please check if the screws are used correctly and adjust the tightness of the screws.

FR: Insérer la vis dans le trou avant la fin de l'assemblage, serrer la vis, mais ne pas serrer à 100%, 70% ~ 80% est correct. Enfin, une fois que toutes les vis sont bien serrées, toutes les vis sont serrées à 100%. Si vous rencontrez ces problèmes, par exemple si les trous ne sont pas alignés ou si certaines pièces ne peuvent pas être montées, vérifiez que les vis sont utilisées correctement et Ajustez leur serrage.

Detailansicht 1/2

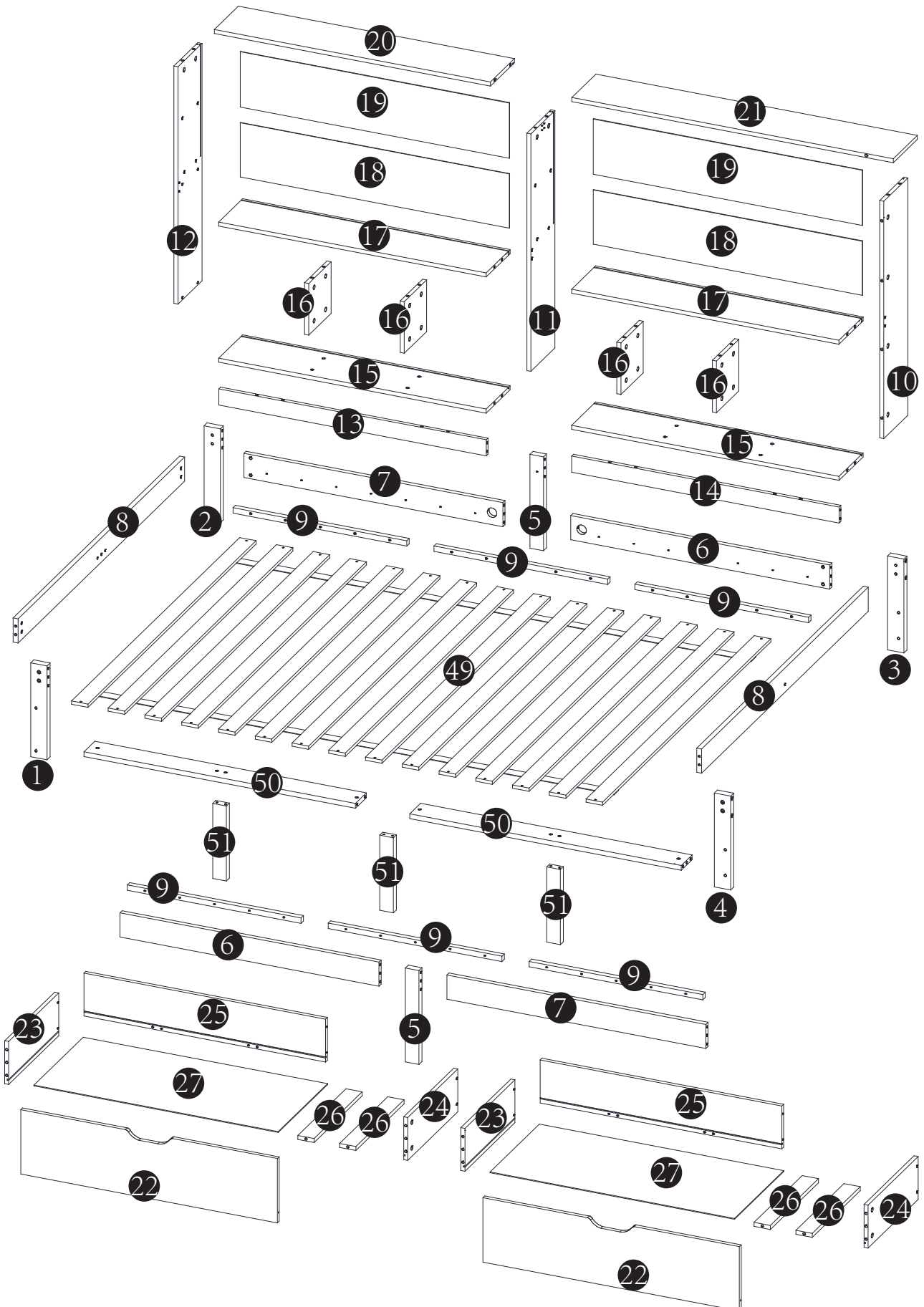

Detailansicht2/2

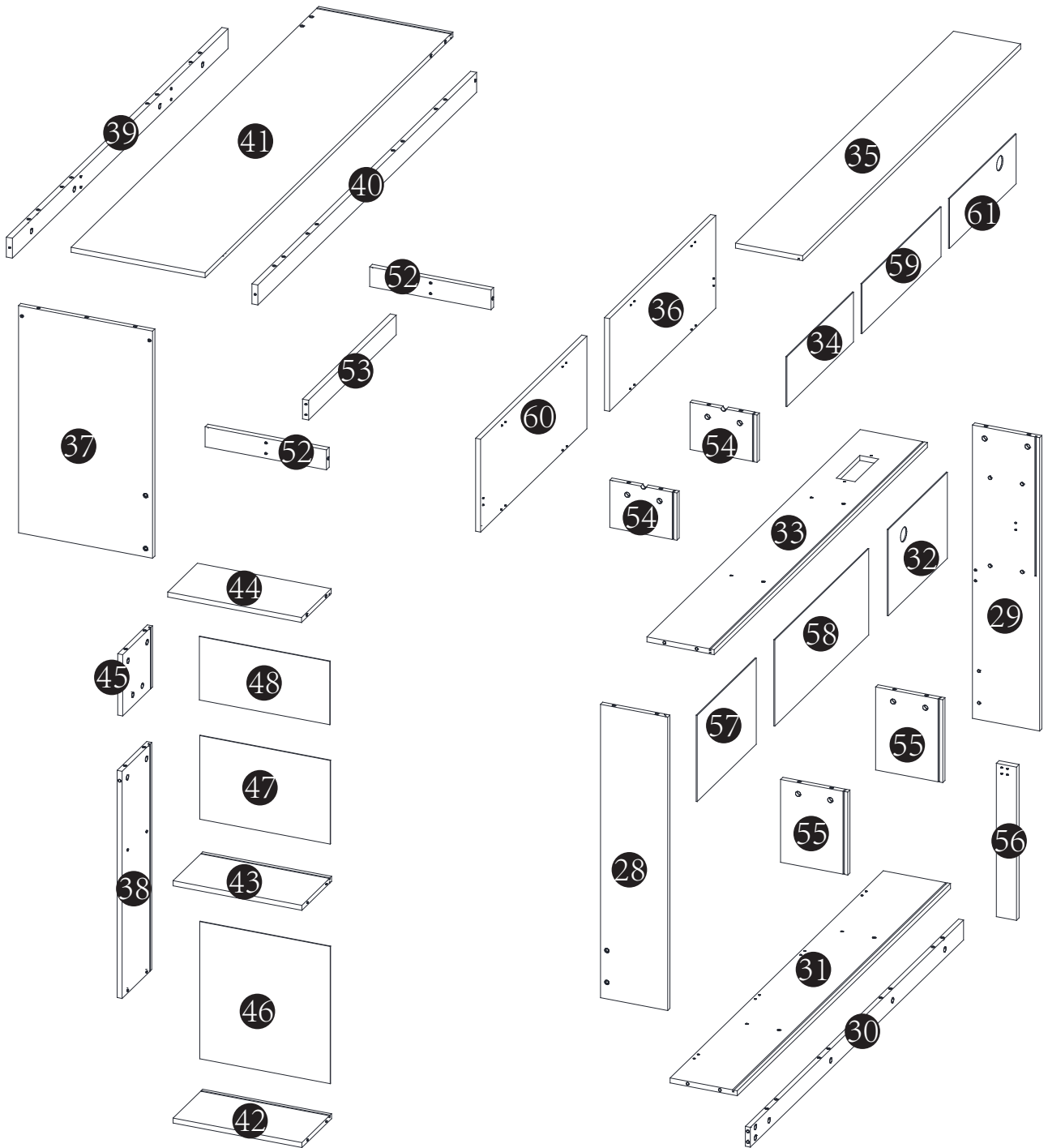

N879P305737

30 × 1

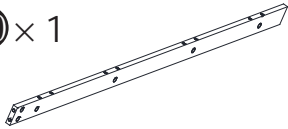

31 × 1

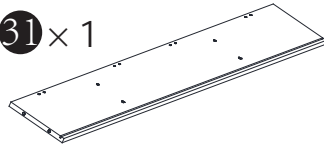

33 × 1

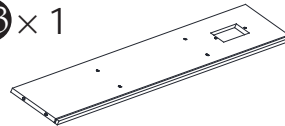

35 × 1

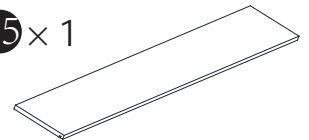

39 × 1

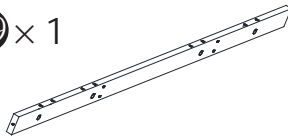

40 × 1

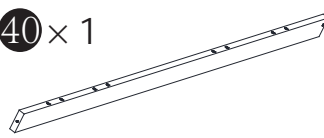

41 × 1

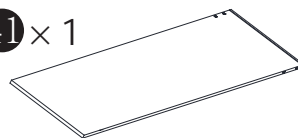

49 × 1

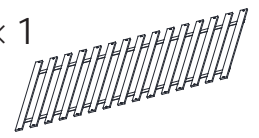

N879P305738

9 × 6

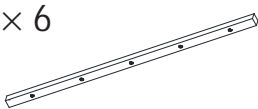

10 × 1

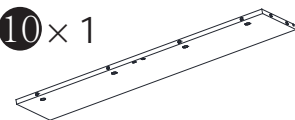

11 × 1

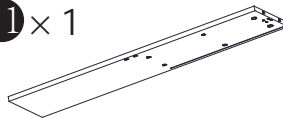

12 × 1

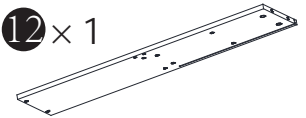

25 × 2

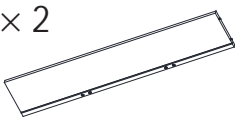

27 × 2

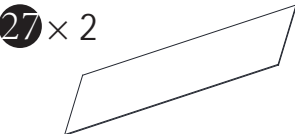

28 × 1

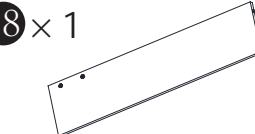

29 × 1

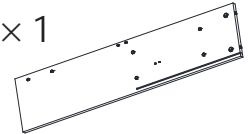

32 × 1



34 × 1

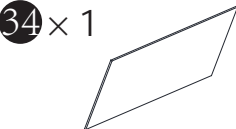

36 × 1

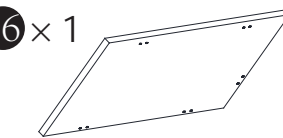

37 × 1

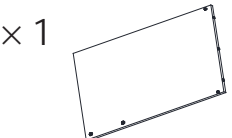

38 × 1

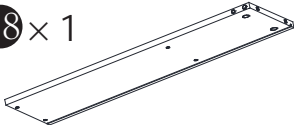

46 × 1

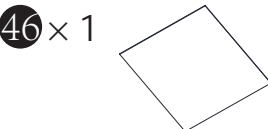

47 × 1

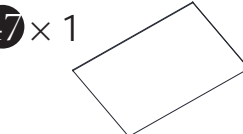

48 × 1

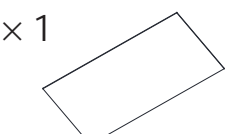

57 × 1



58 × 1

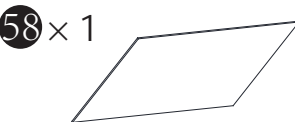

59 × 1

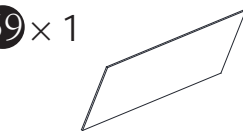

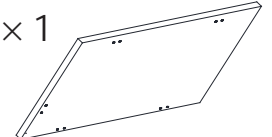

60 × 1

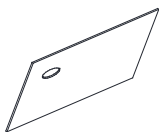

61 × 1



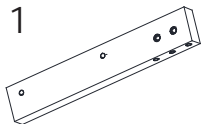
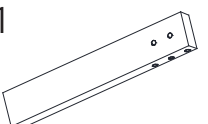
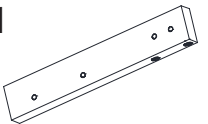
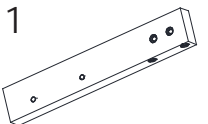
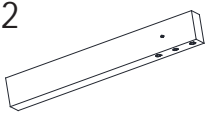
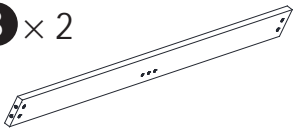

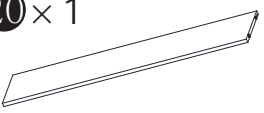
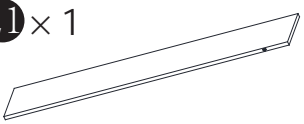
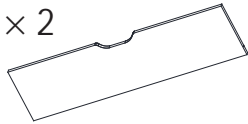
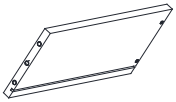
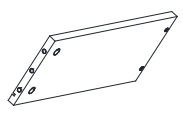
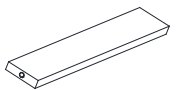
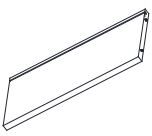
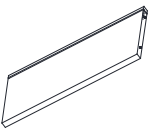
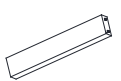
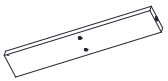
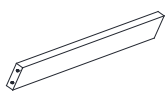
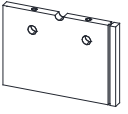
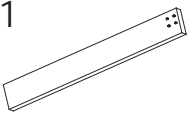



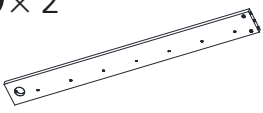
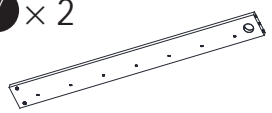
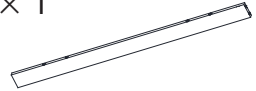
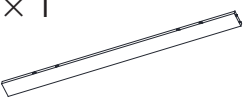
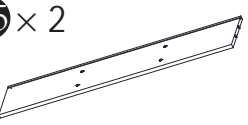
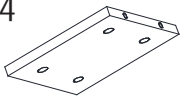
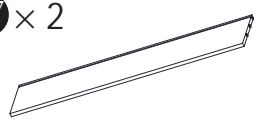
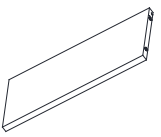
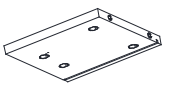
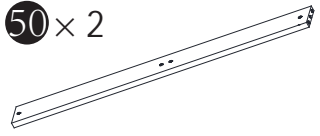
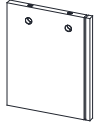











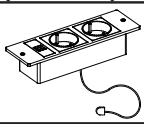

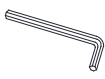

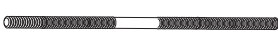

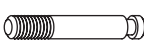

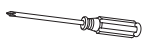
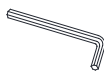
N879P305739

1 × 1 	2 × 1 	3 × 1 	4 × 1 
5 × 2 	8 × 2 	18 × 2 	19 × 2 
20 × 1 	21 × 1 	22 × 2 	23 × 2 
24 × 2 	26 × 4 	42 × 1 	43 × 1 
51 × 3 	52 × 2 	53 × 1 	54 × 2 
56 × 1 			

N879P305740

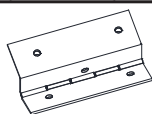
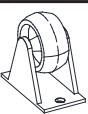
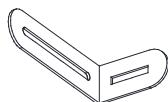
6 × 2 	7 × 2 	13 × 1 	14 × 1 
15 × 2 	16 × 4 	17 × 2 	44 × 1 
45 × 1 	50 × 2 	55 × 2 	

N879P305739

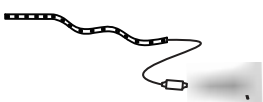
A 	B 	C 	D 
M6*100mm(8PCS)	M6*60mm(10PCS)	M6*35mm(6PCS)	M6*15mm(6PCS)
E 	F 	G 	H 
(18PCS)	Φ4*30mm(60PCS)	Φ8*40mm(43PCS)	Φ3.5*14mm(160PCS)
I 	J 	K 	L 
(1PC)	(4PCS)	M3(1PC)	(4PCS)
M 	N 	O 	P 
M6*120mm(2PCS)	(2PCS)	(112PCS)	(112PCS)
Q 	R 	S 	T 
(1PC)	M4(2PCS)	(4PCS)	Φ5*40mm(50PCS)
U 	V 	W 	X 
(60PCS)	(3PCS)	(1PC)	(4PCS)
Y 	Z 	A1 	A2 
(4PCS)	(8PCS)	(2PCS)	(6PCS)
A3 	A4 	A5 	A6 
(176PCS)	M6*25mm(1PC)	Φ3.5*14mm (3PCS)	(1PC)

VERWENDEN SIE KEINE POWER TOOLS, um dieses Produkt zusammenzubauen!



Do not use power tools to assemble this product!

A		B	
M6*100mm		M6*60mm	

DE:Bitte beachten Sie, dass die Formen der Schrauben A und B ähnlich sind. Bitte installieren Sie entsprechend der Anleitung und unterscheiden Sie sie!

UK:Please note that the shapes of screws A and B are similar. Please install according to the instructions and distinguish them!



FR:Notez que les vis A et B ont des formes similaires. Veuillez les installer en suivant les instructions pour les séparer!

F		H	
Φ4*30mm		Φ3.5*14mm	

DE:Bitte beachten Sie, dass die Formen der Schrauben F und H und J ähnlich sind. Bitte installieren Sie entsprechend der Anleitung und unterscheiden Sie sie!

UK:Please note that the shapes of screws F and H and J are similar. Please install according to the instructions and distinguish them!

FR:Notez que les vis F et H et J ont des formes similaires. Veuillez les installer en suivant les instructions pour les séparer!

C		A4	
M6*35mm		M6*25mm	

DE:Bitte beachten Sie, dass die Formen der Schrauben C und A4 ähnlich sind. Bitte installieren Sie entsprechend der Anleitung und unterscheiden Sie sie!

UK:Please note that the shapes of screws C and A4 are similar. Please install according to the instructions and distinguish them!

FR:Notez que les vis C et A4 ont des formes similaires. Veuillez les installer en suivant les instructions pour les séparer!

01

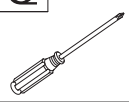
O	Q
	
42PCS	1PC

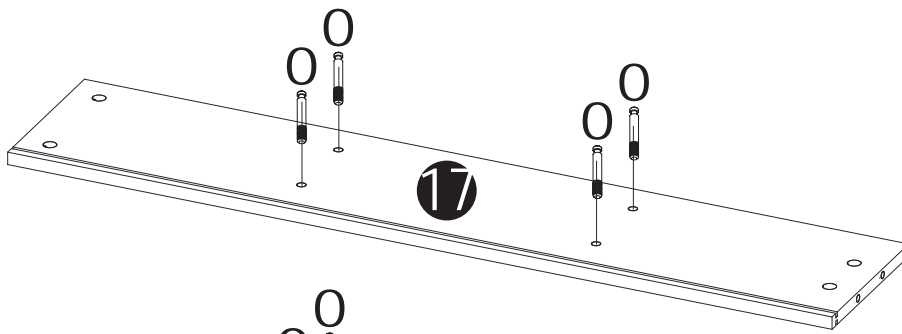
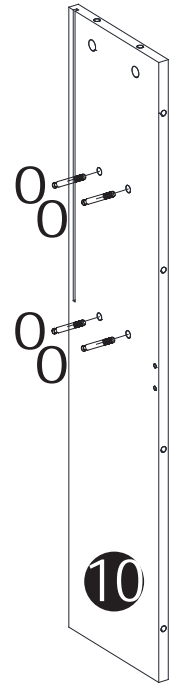
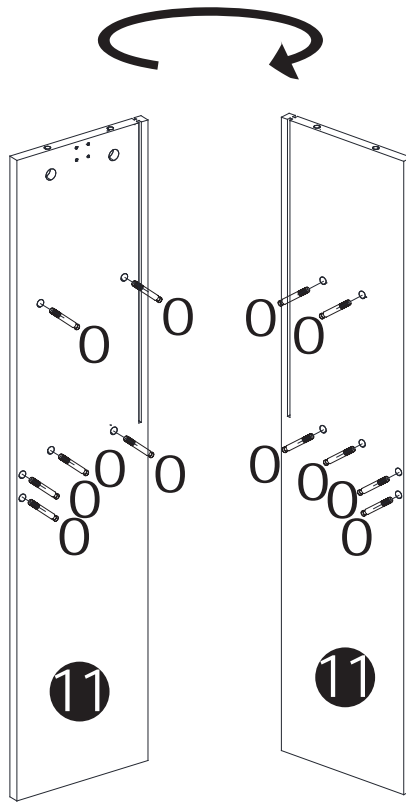
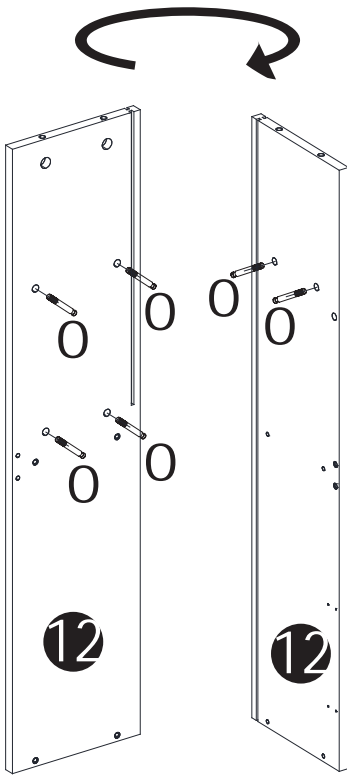

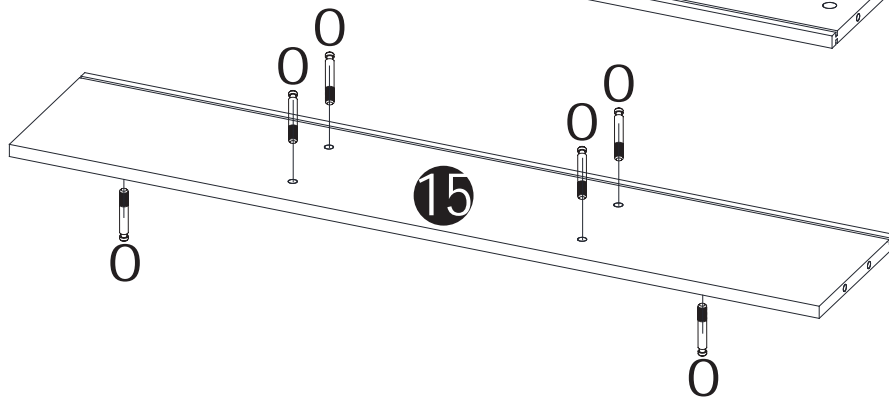

× 2



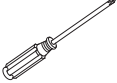

× 2

02

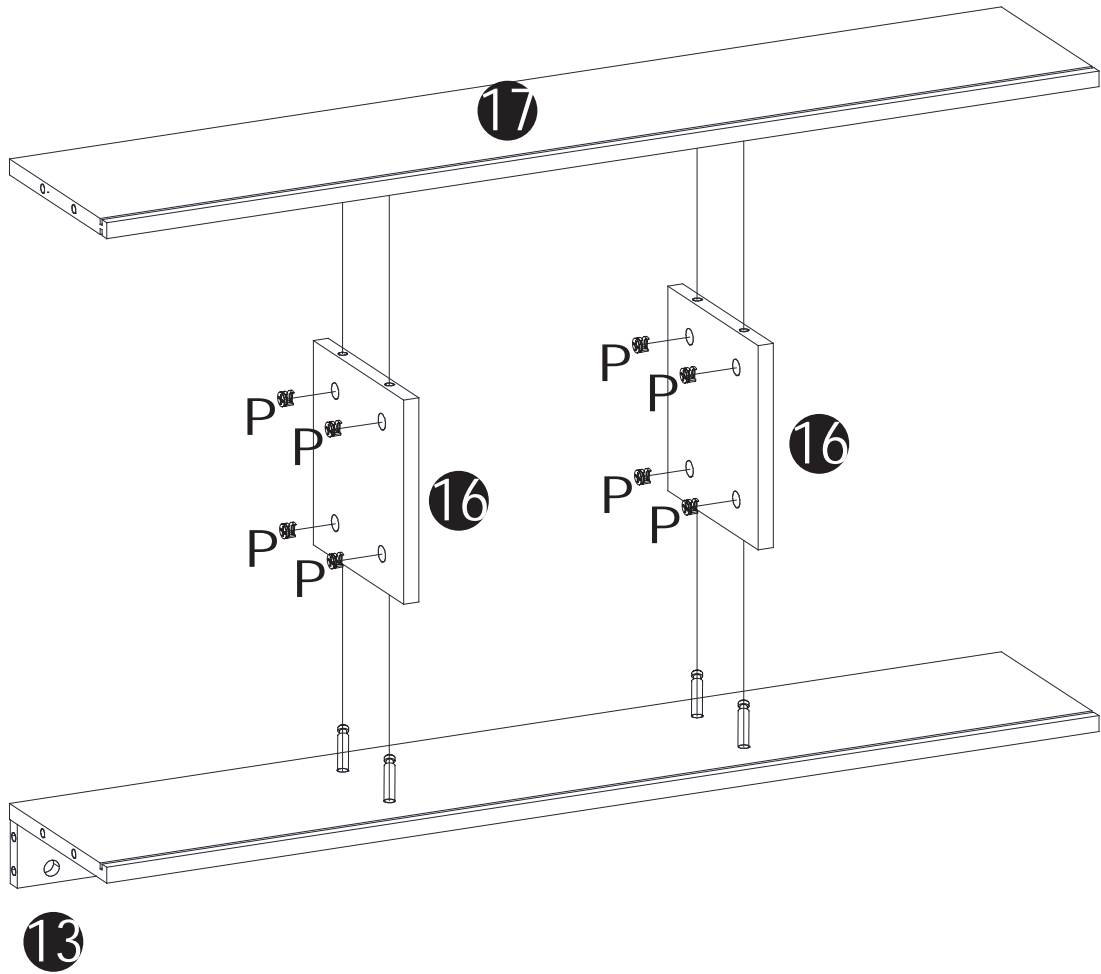
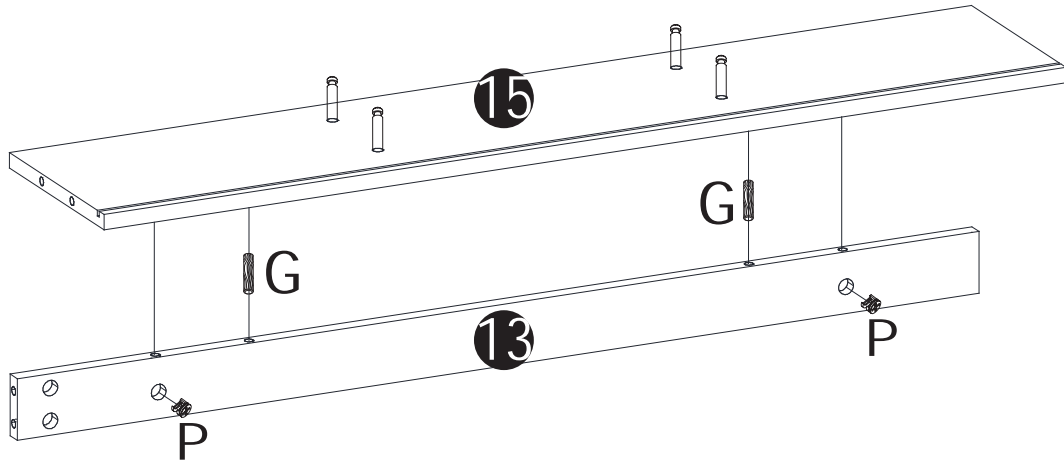
G	P	Q
		
2PCS	10PCS	1PC

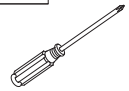

03

G	P	Q
		
2PCS	10PCS	1PC

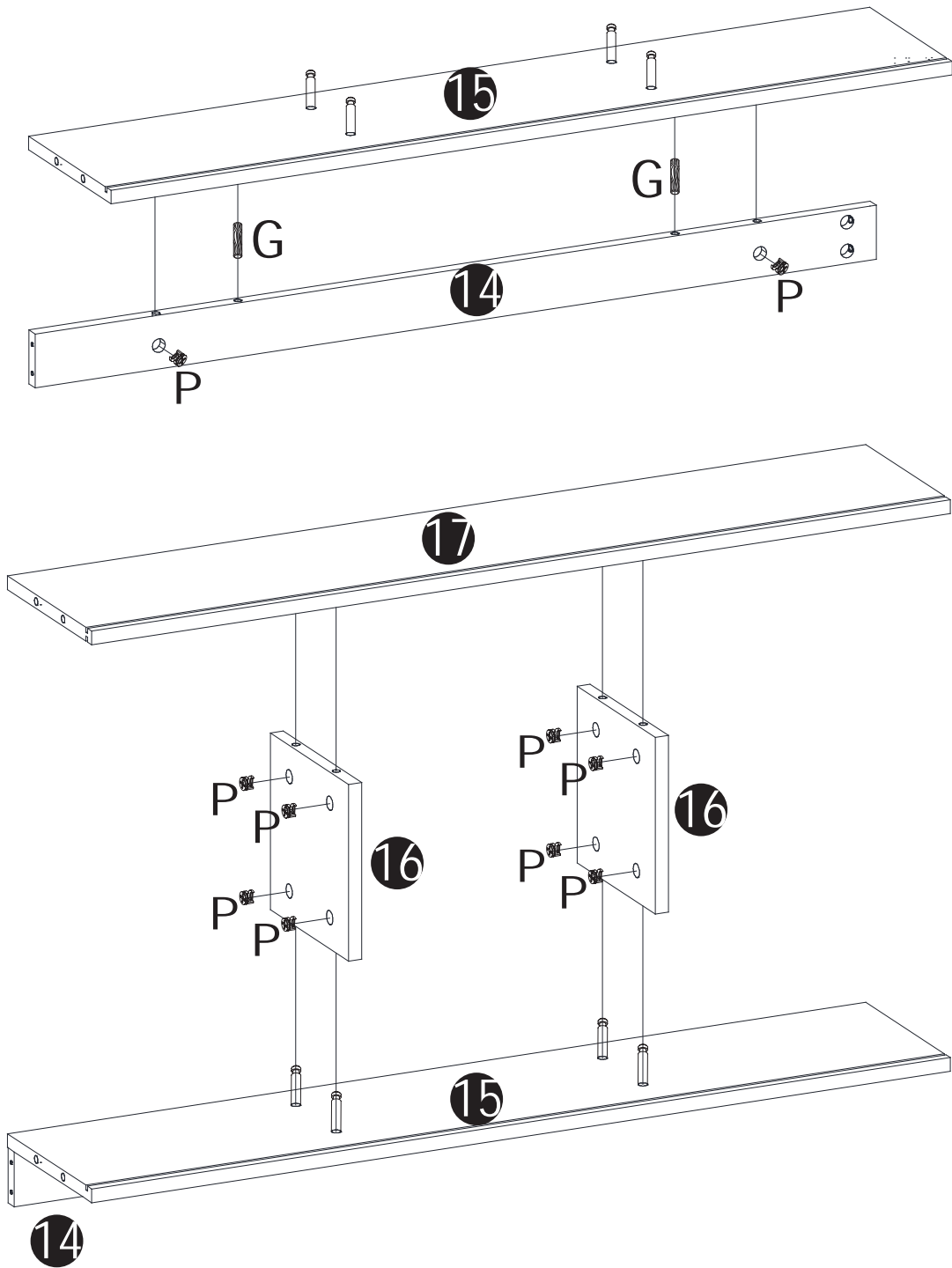

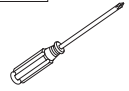

04

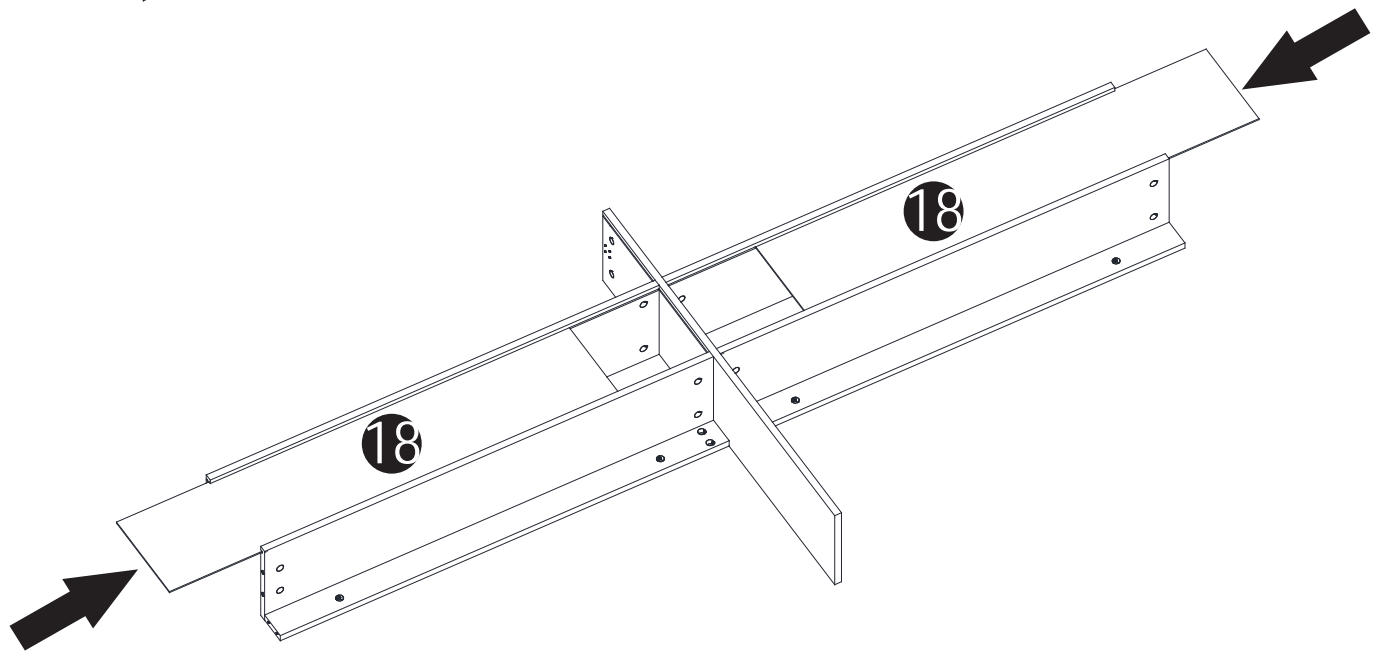
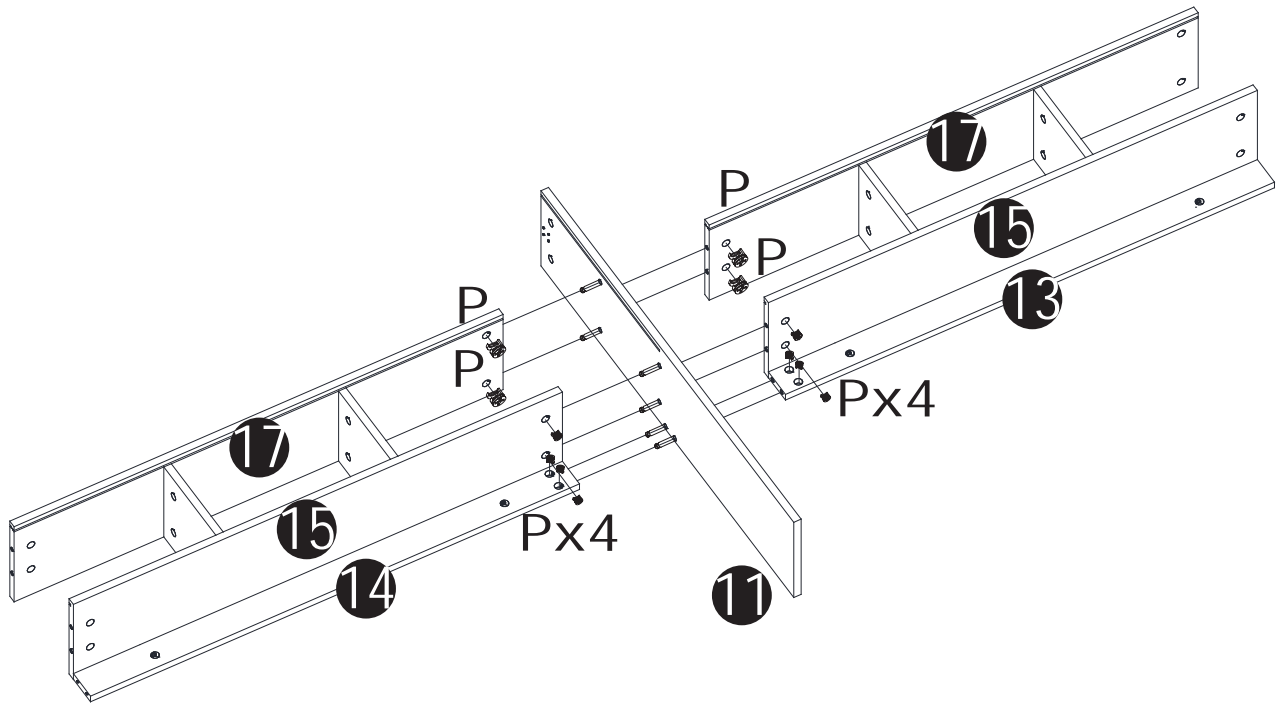
P	Q
	
12PCS	1PC



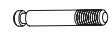

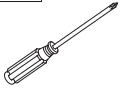
05

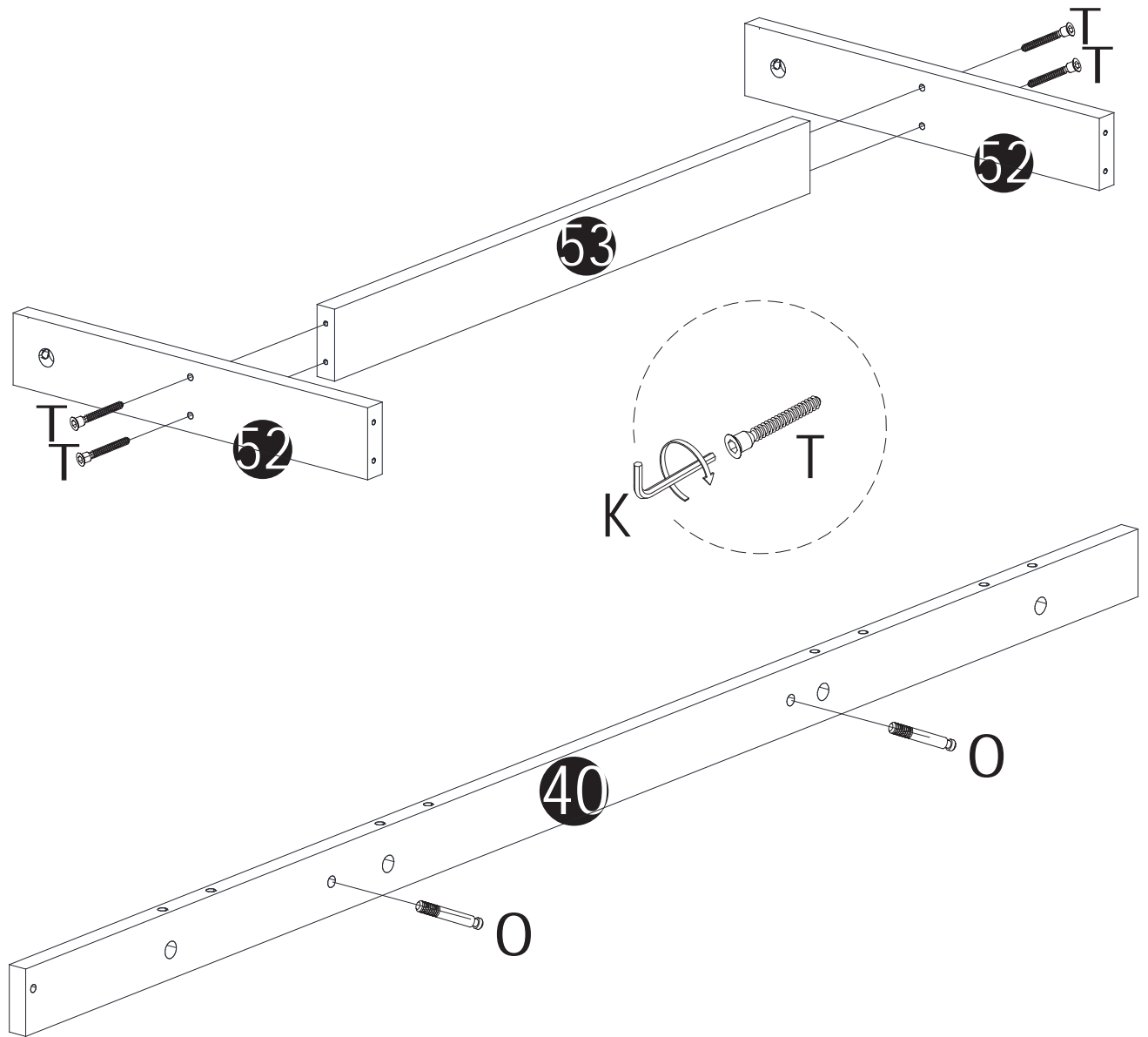
O	T	K	Q
			
2PCS	4PCS	1PC	1PC



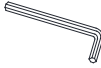
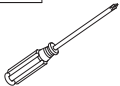

06

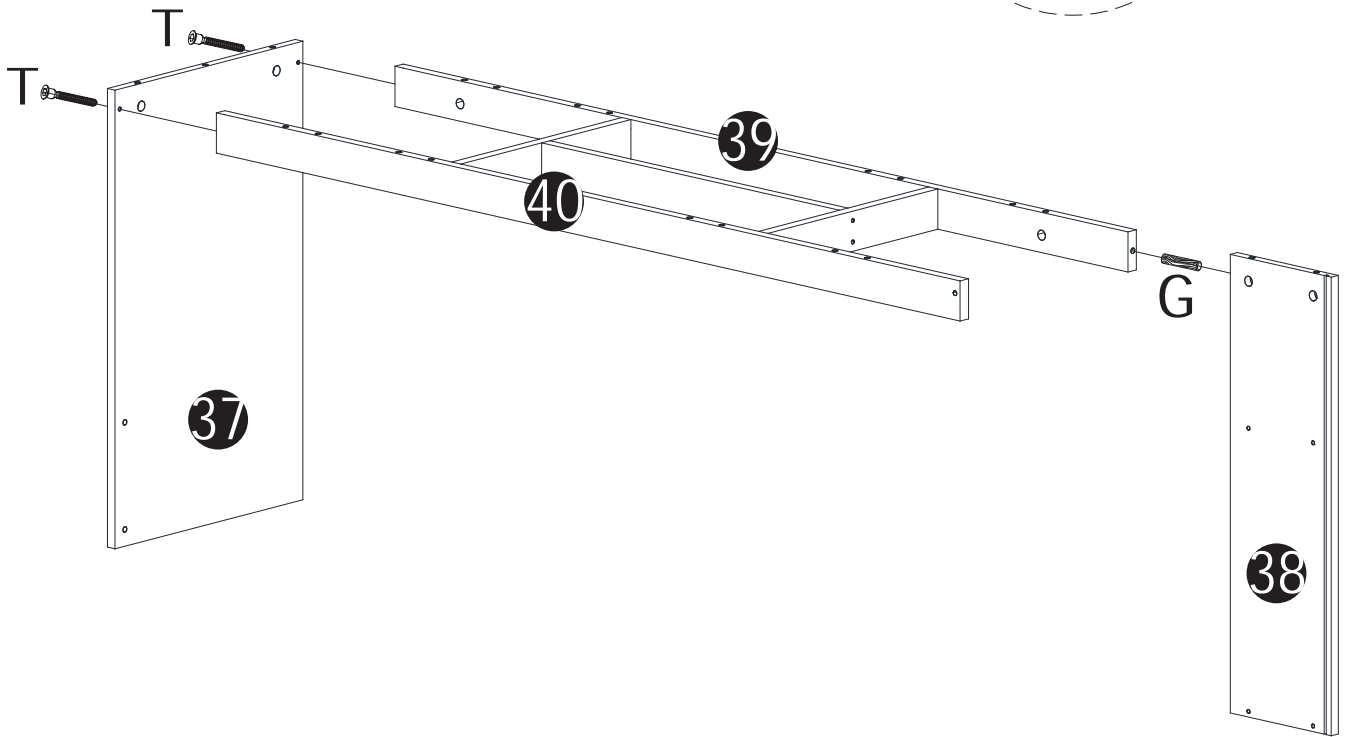
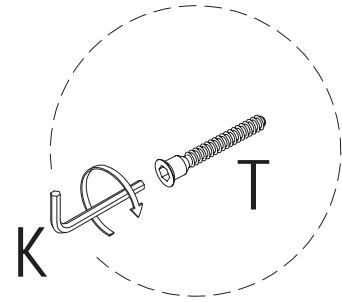
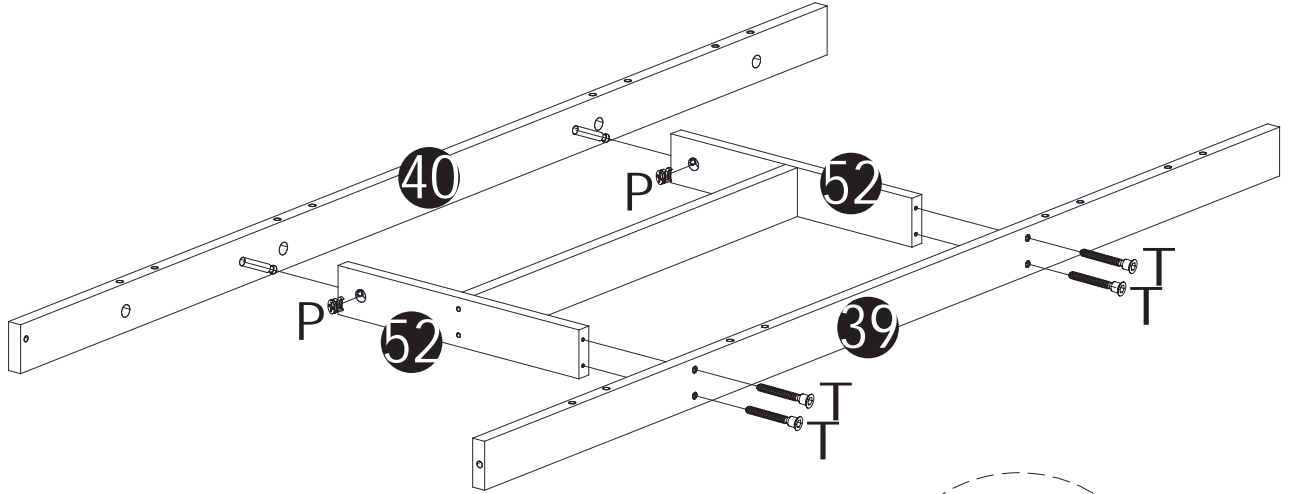
P	G	T	K	Q
				
2PCS	1PC	6PCS	1PC	1PC



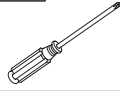

07

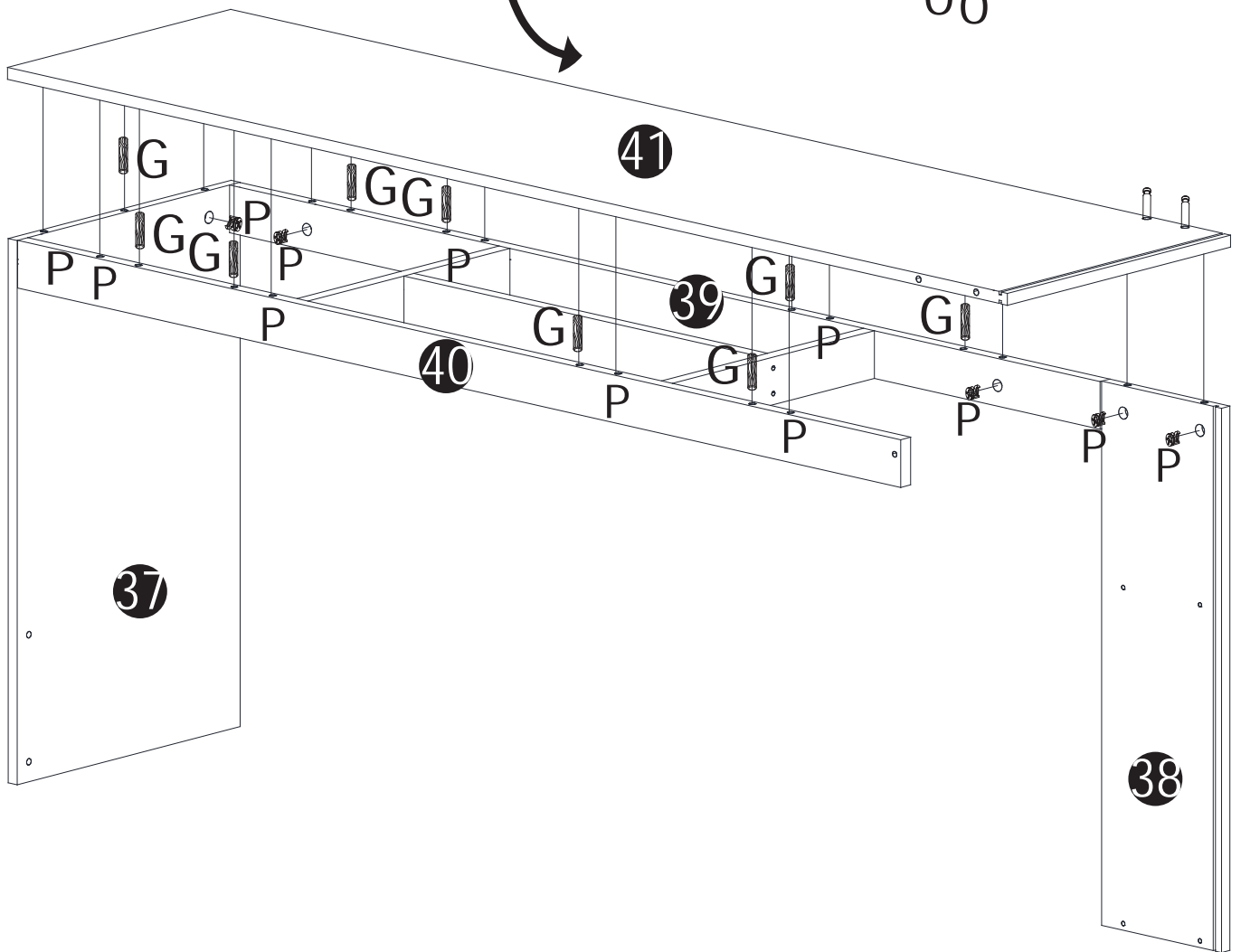
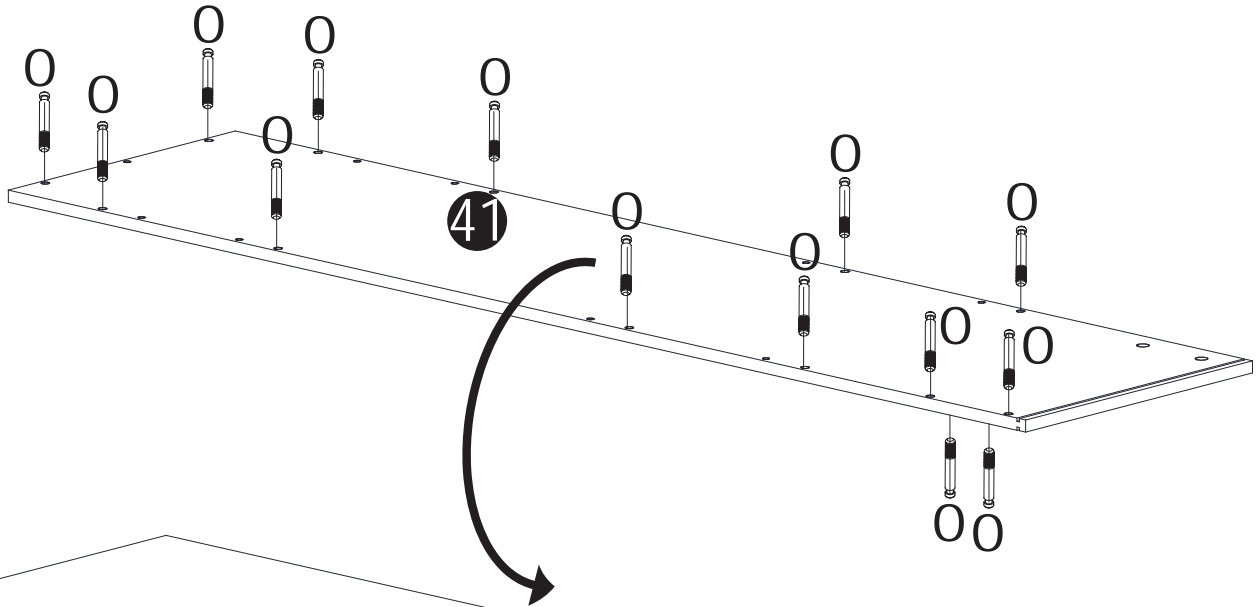
G	O	P	Q
			
9PCS	14PCS	12PCS	1PC





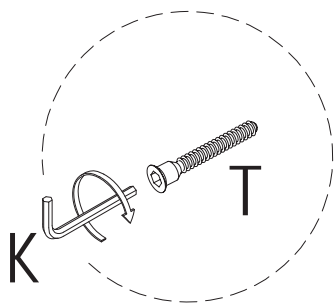
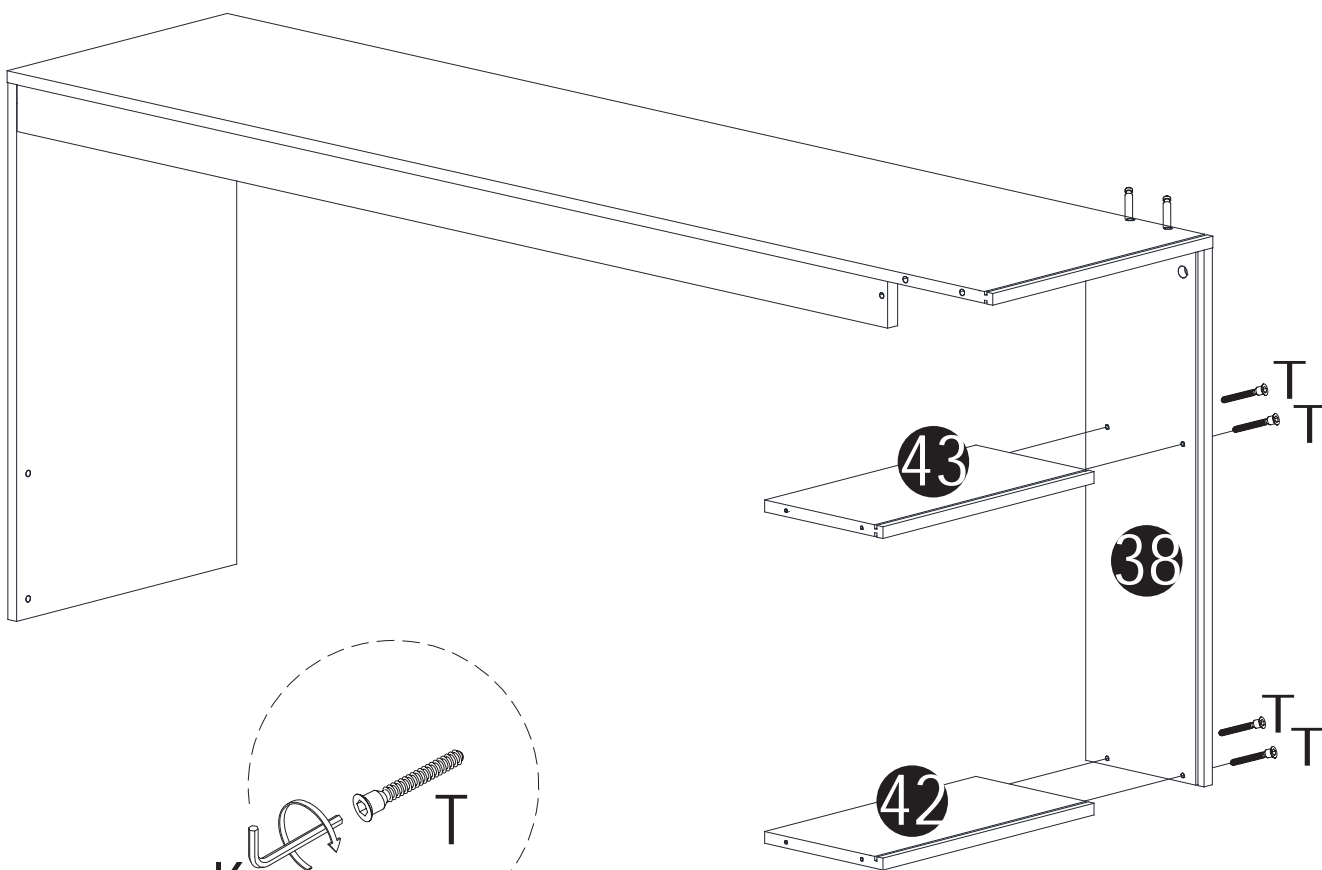

08

T	K
	
4PCS	1PC

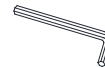

09

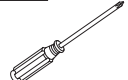
R	A4	T	K	P	Q
					
1PC	1PC	4PCS	1PC	2PCS	1PC

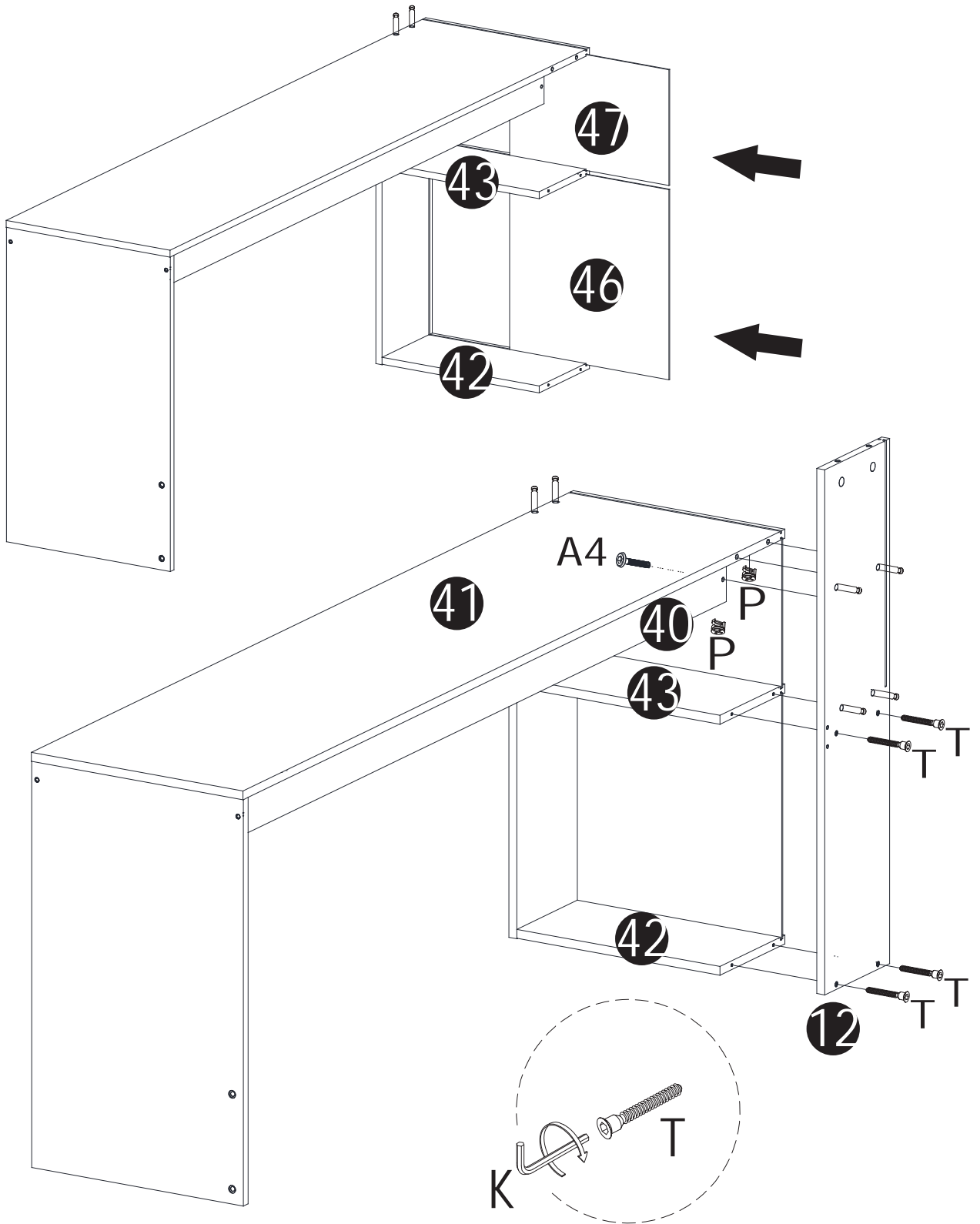

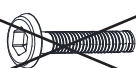
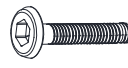

C	A4
	
M6*30mm	M6*25mm(1PC)

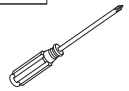
10

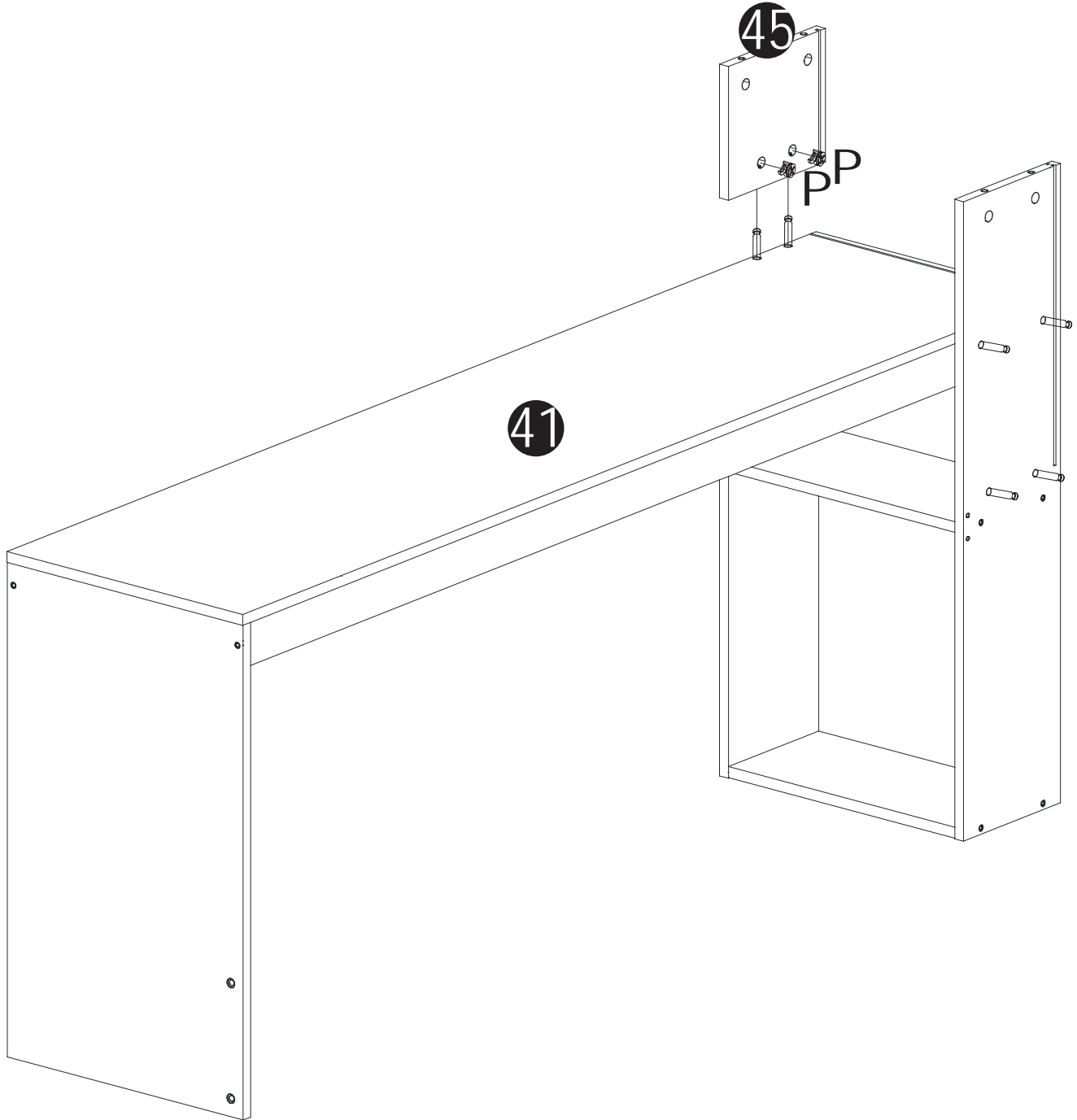
P	Q
	
2PCS	1PC



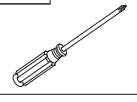

11

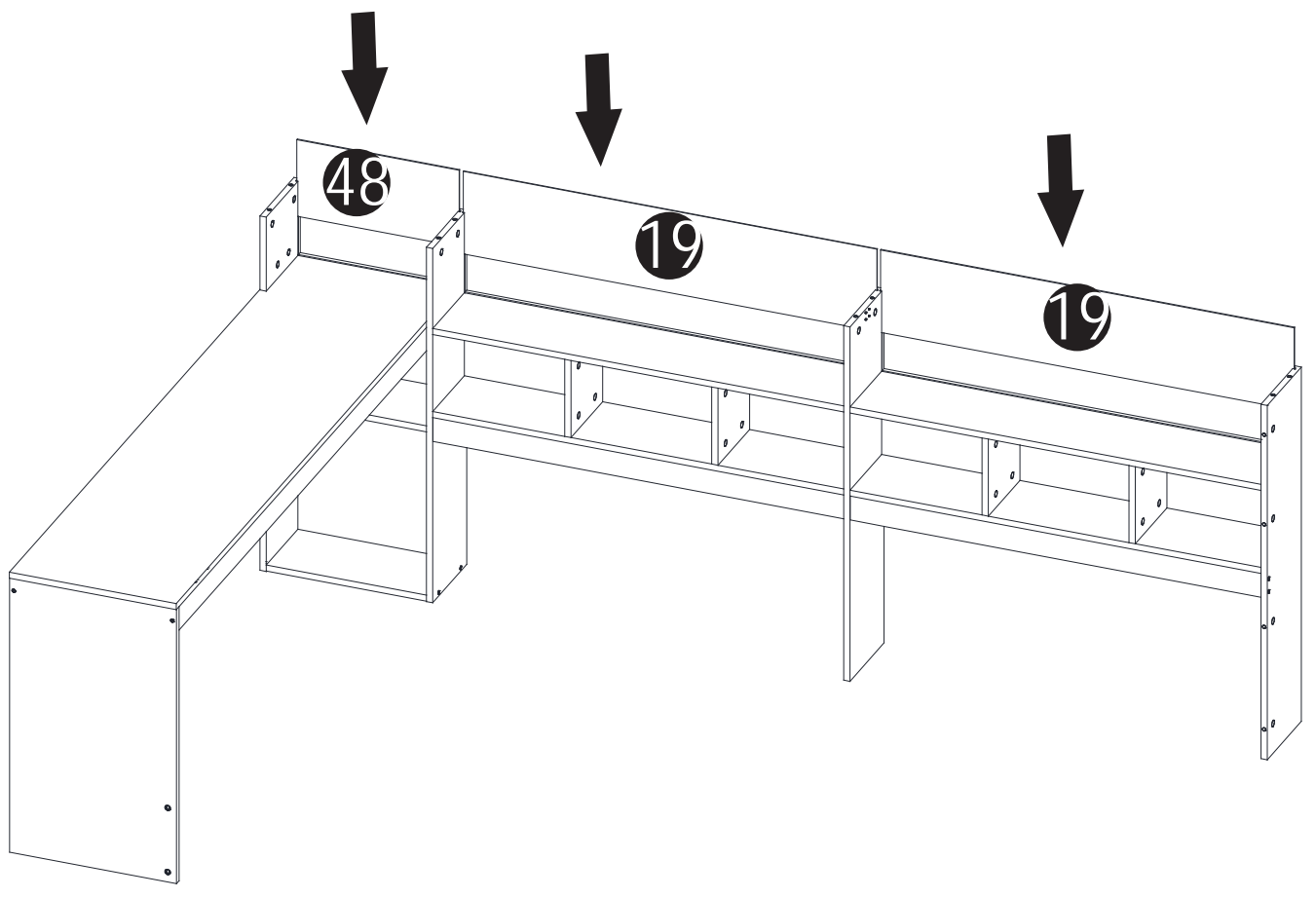
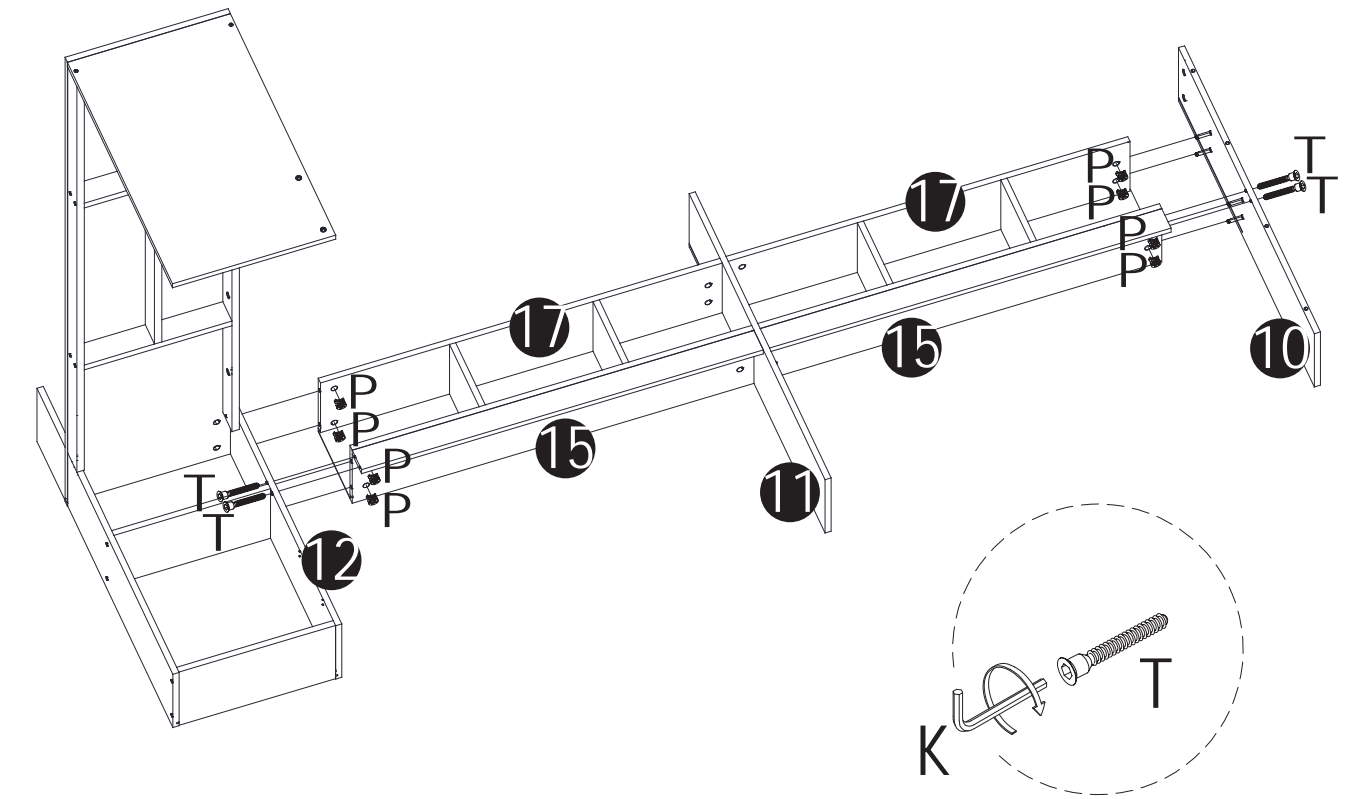
T	K	P	Q
			
4PCS	1PC	8PCS	1PC



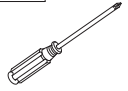

12

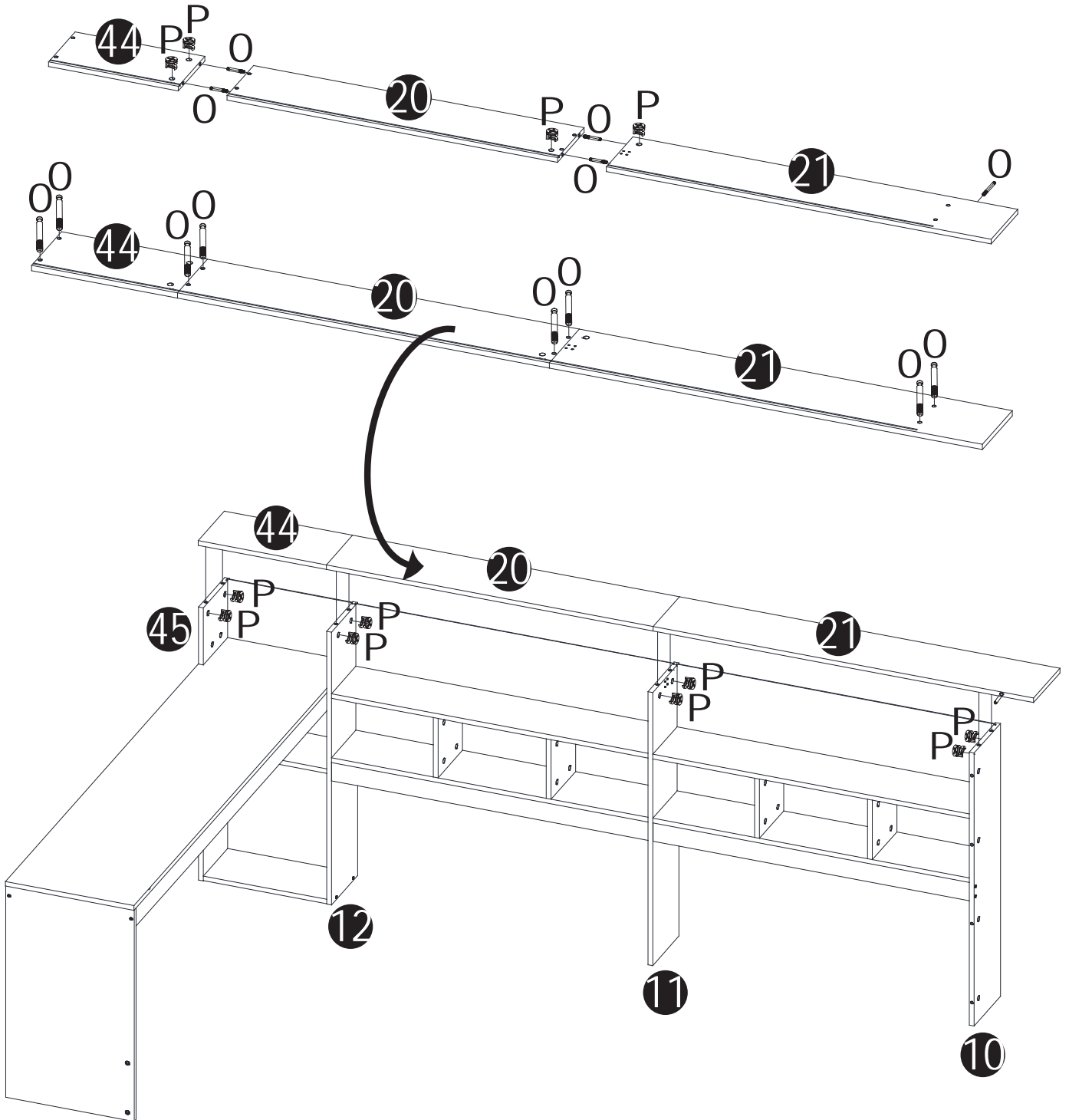

O	P	Q
		
13PCS	12PCS	1PC

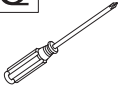

13

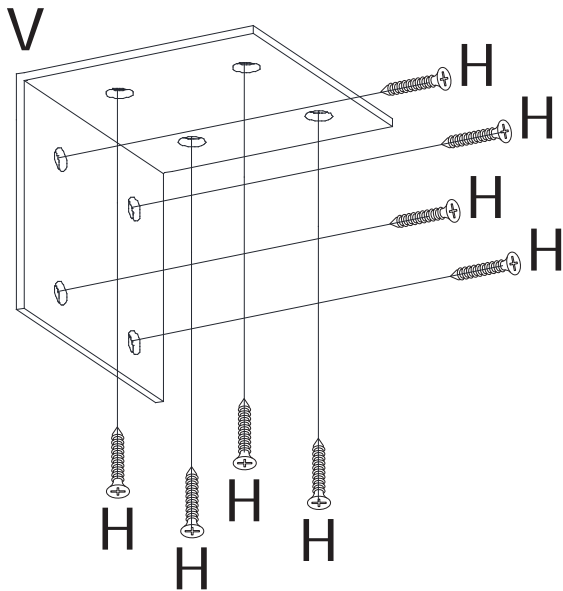
V	H	Q
		
1PC	8PCS	1PC



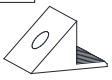
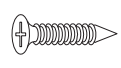
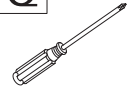

F	H
	
Φ4*30mm	Φ3.5*14mm(8PCS)

14

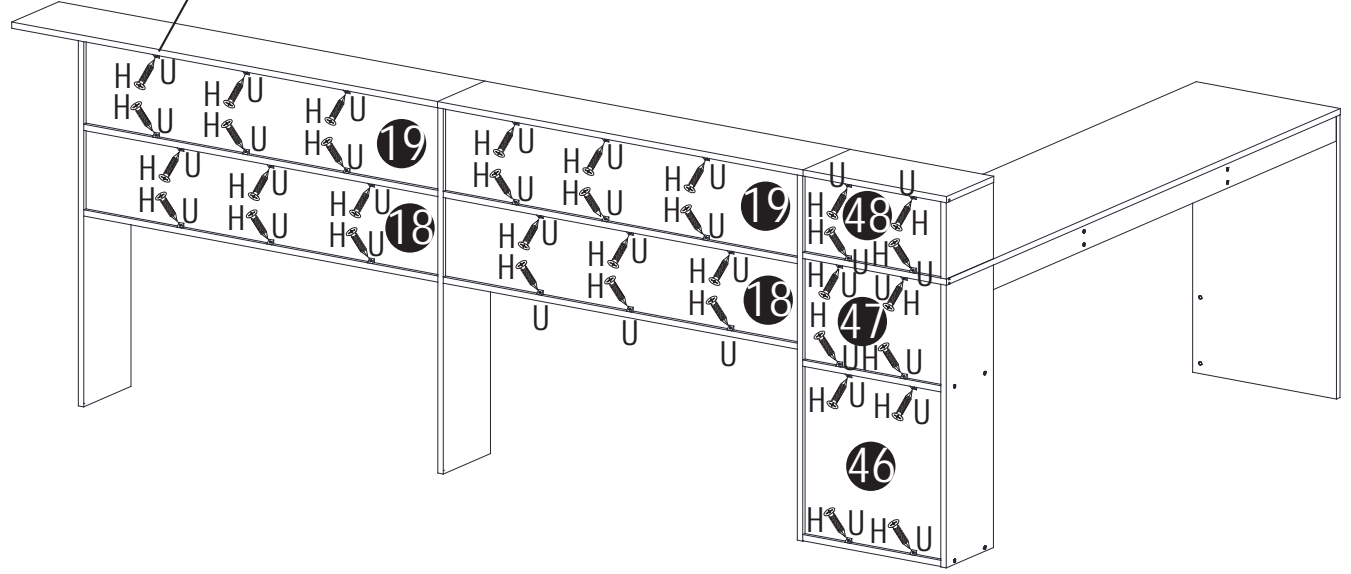
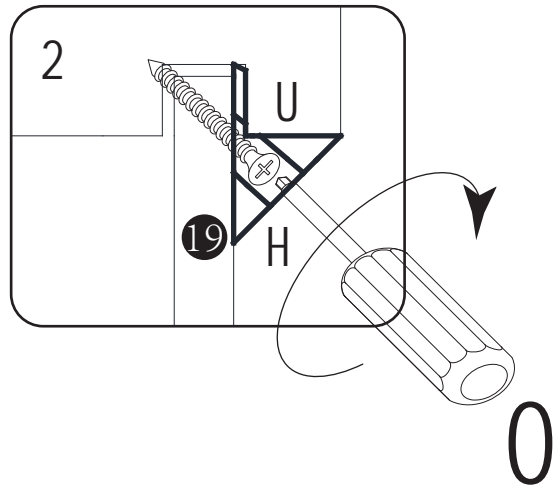
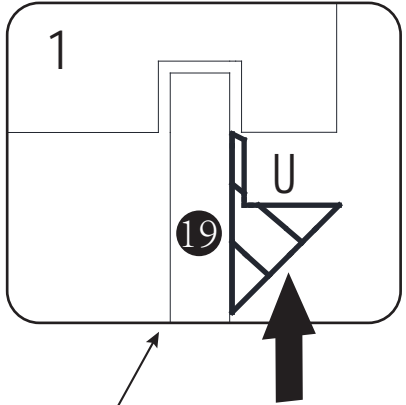
U	H	Q
		
36PCS	36PCS	1PC





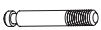
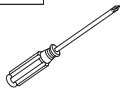

F	H
	
Φ4*30mm	Φ3.5*14mm(36PCS)

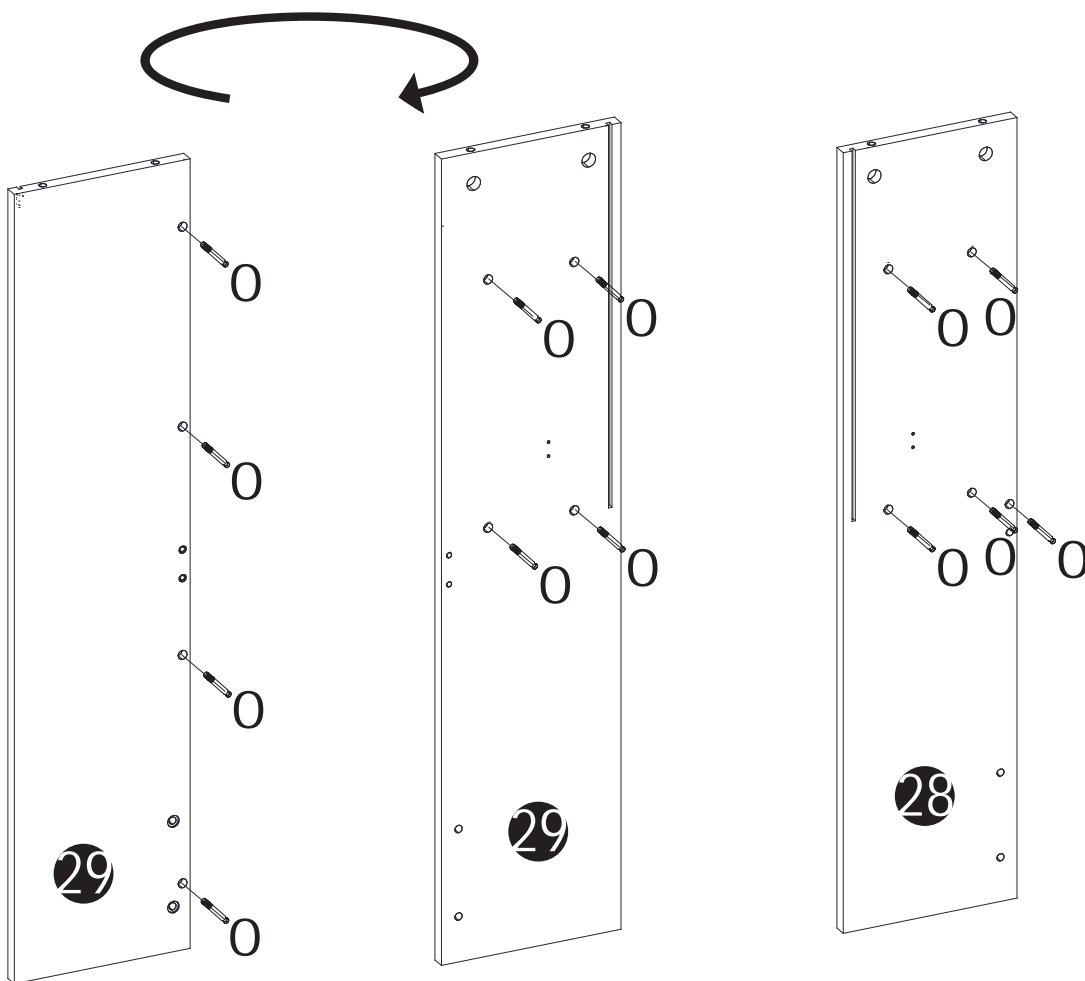
15



0	Q
	
13PCS	1PC



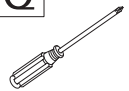

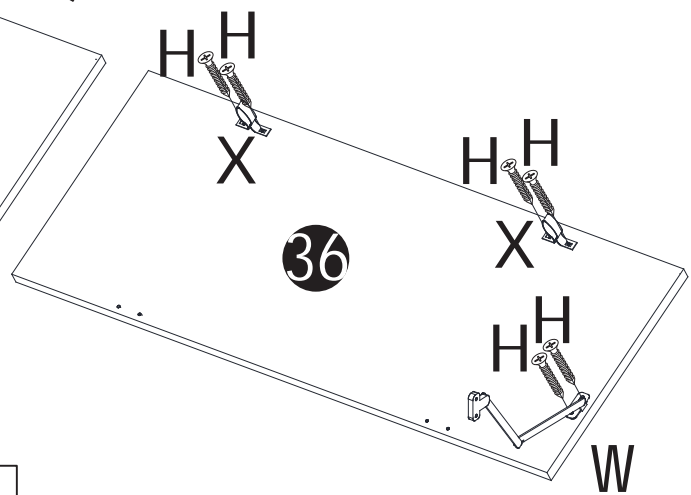
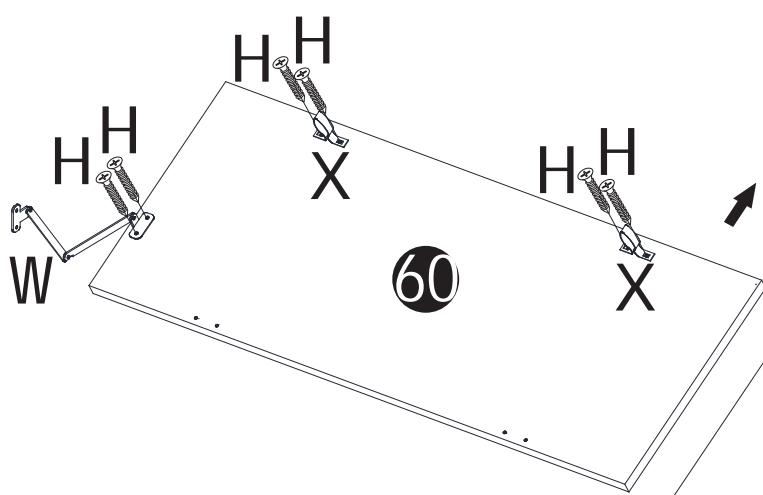
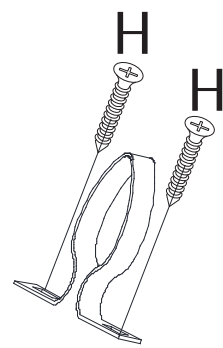
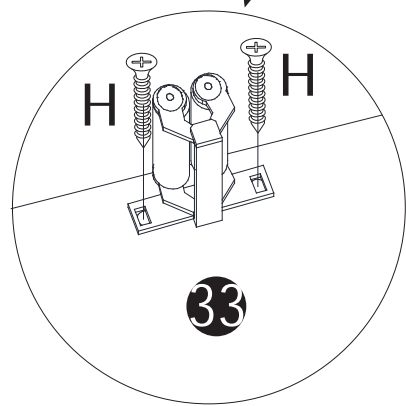
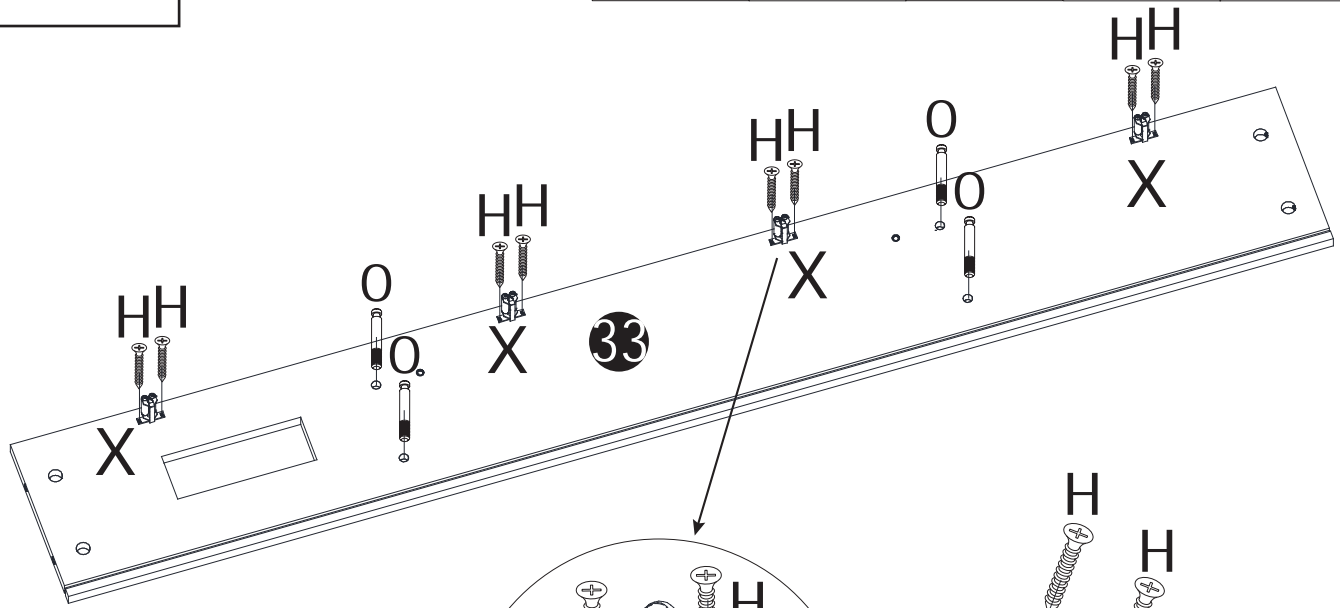

16

O	W	X	H	Q
				
4PCS	1PC	4PCS	20PCS	1PC



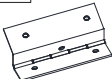

F	H
	
Φ4*30mm	Φ3.5*14mm(20PCS)

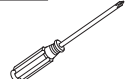

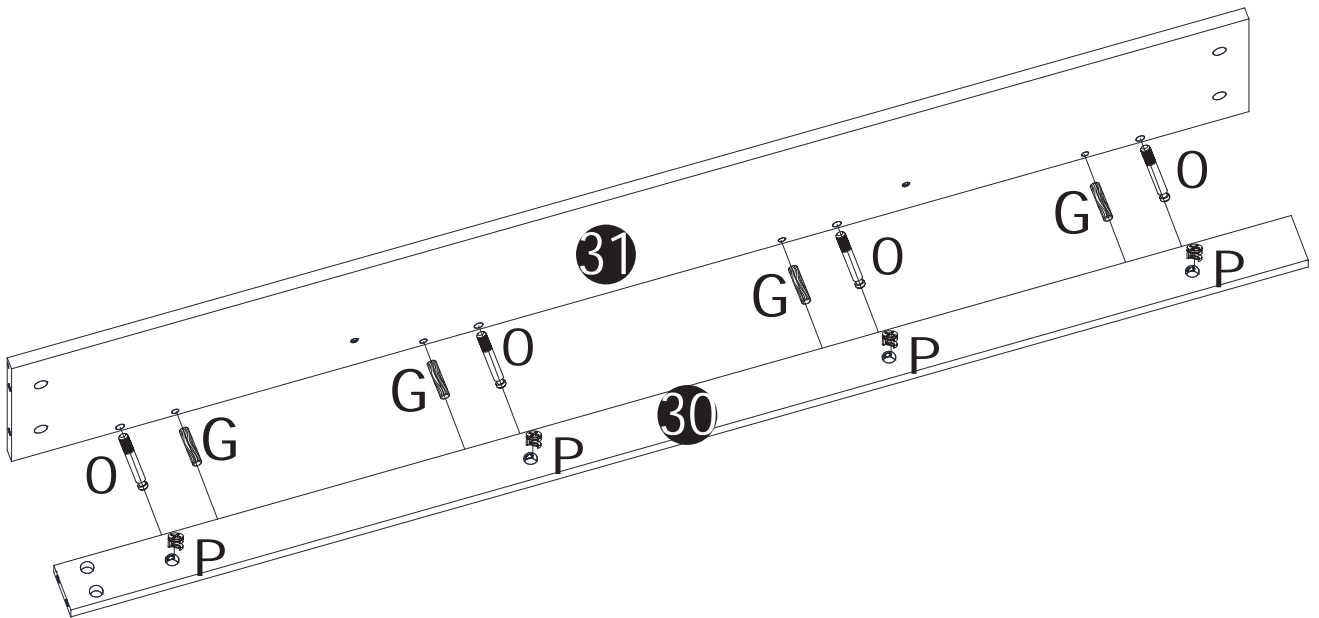
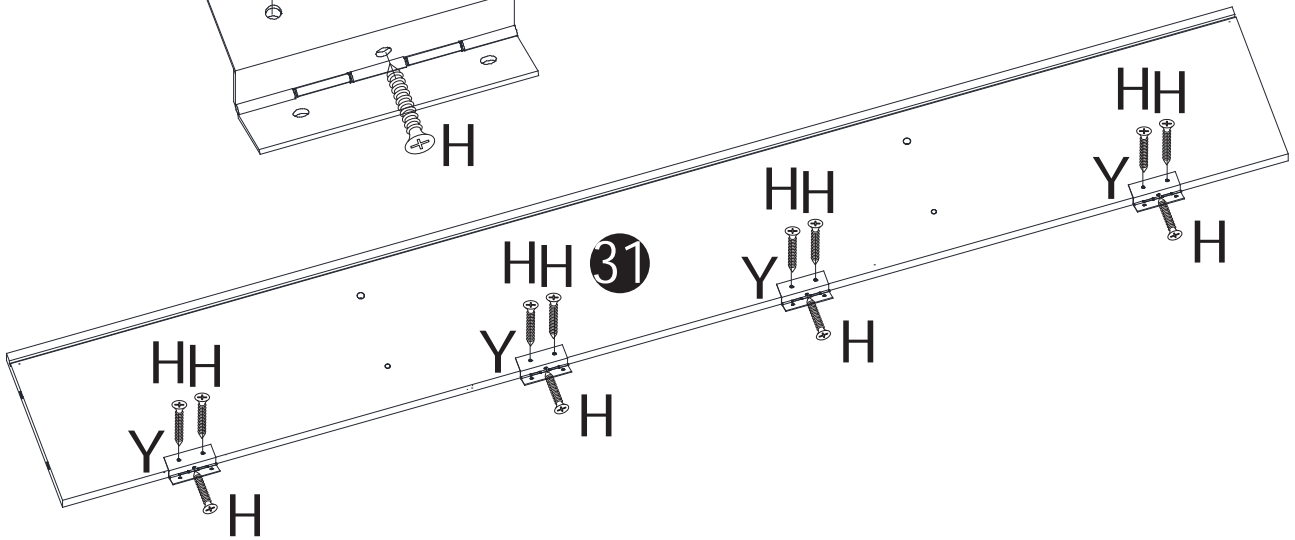
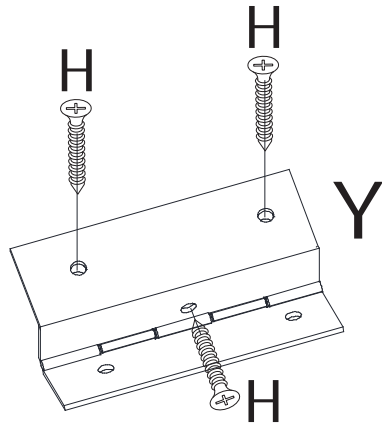

17

G	Y	H	O	P	Q
					
4PCS	4PCS	12PCS	4PCS	4PCS	1PC





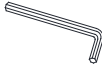

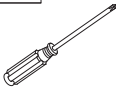
F	H
	
Φ4*30mm	Φ3.5*14mm(12PCS)

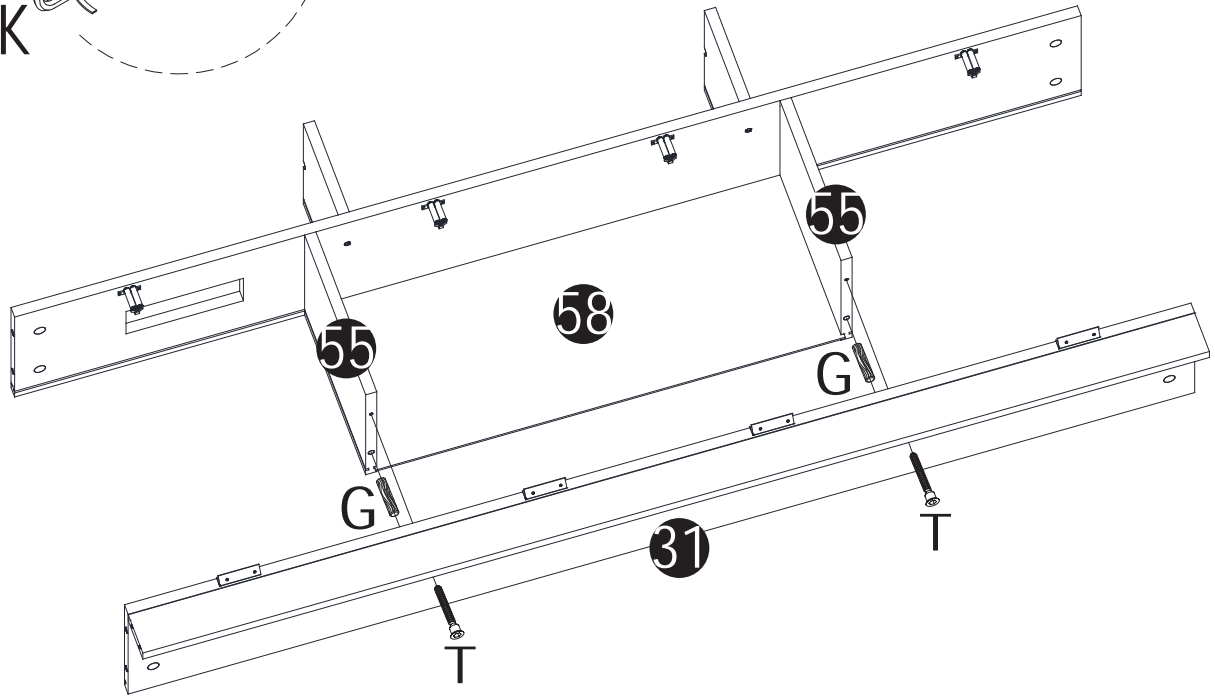
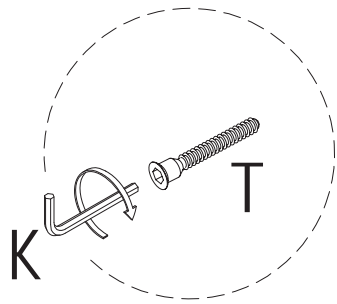
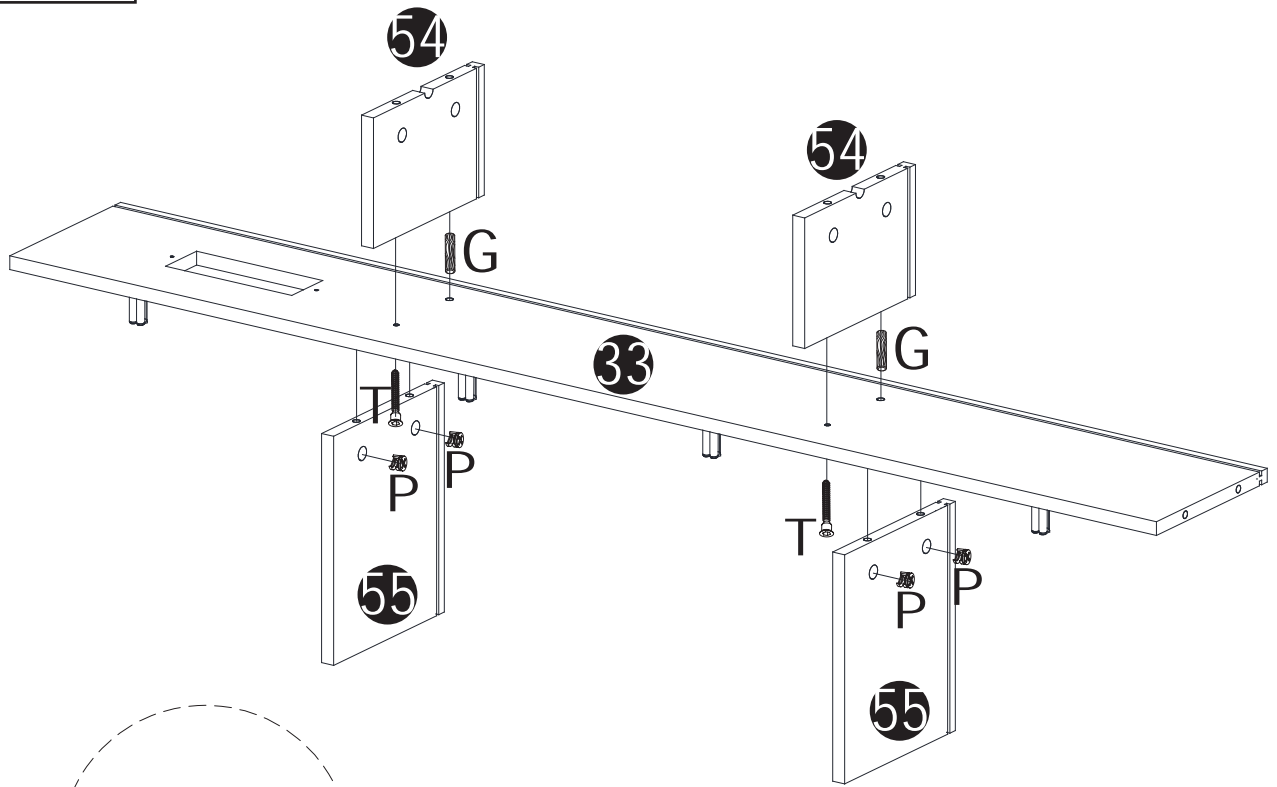
18

G	T	K	P	Q
				
4PCS	4PCS	1PC	4PCS	1PC



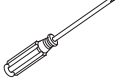

19

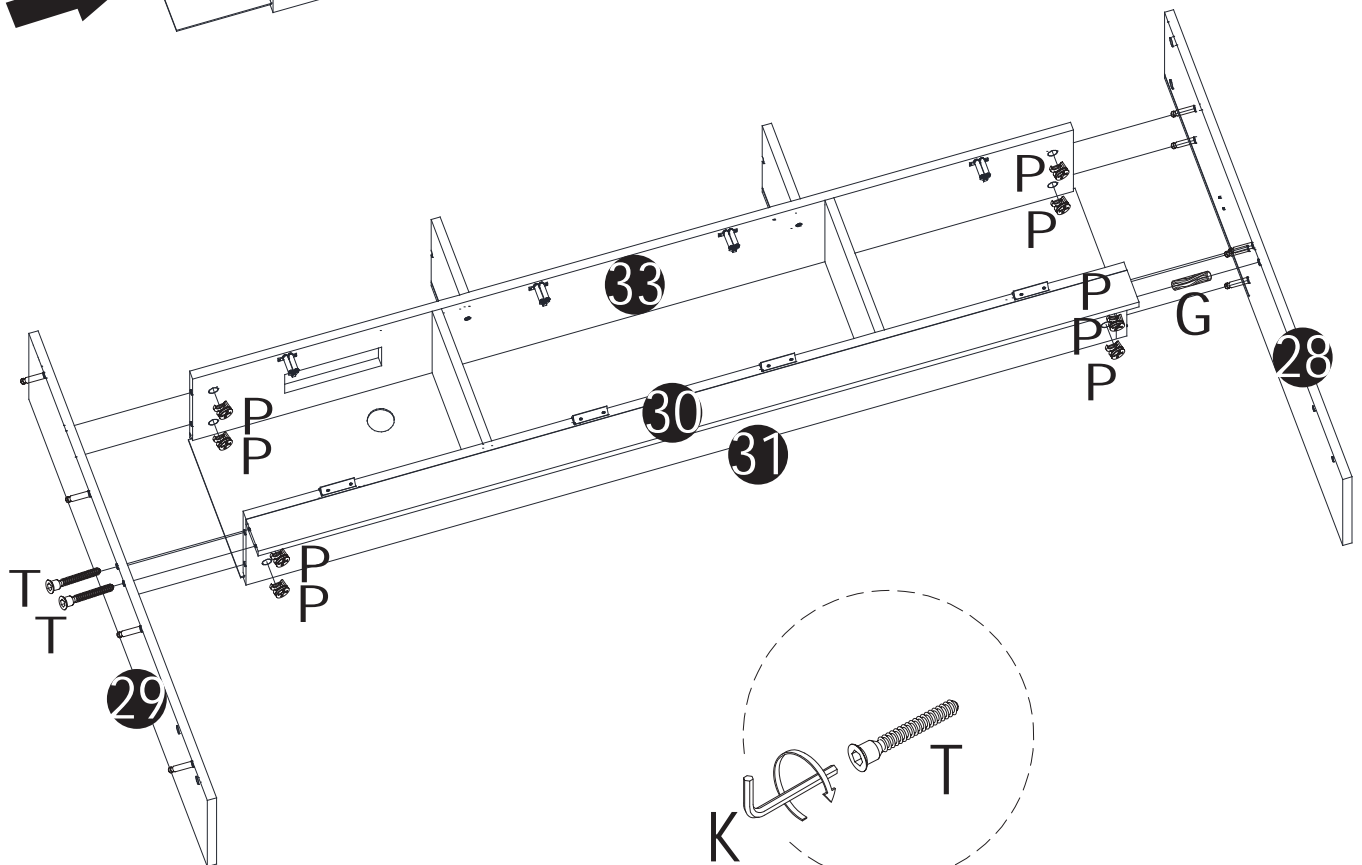
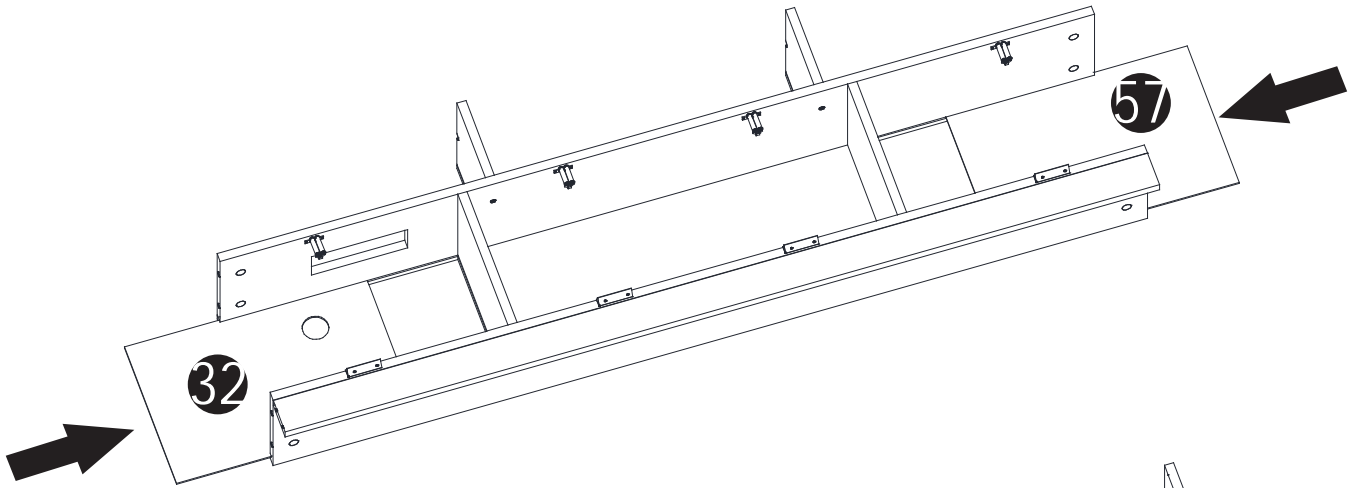

G	T	K	P	Q
				
1PC	2PCS	1PC	9PCS	1PC

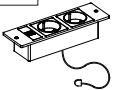

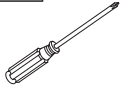
20

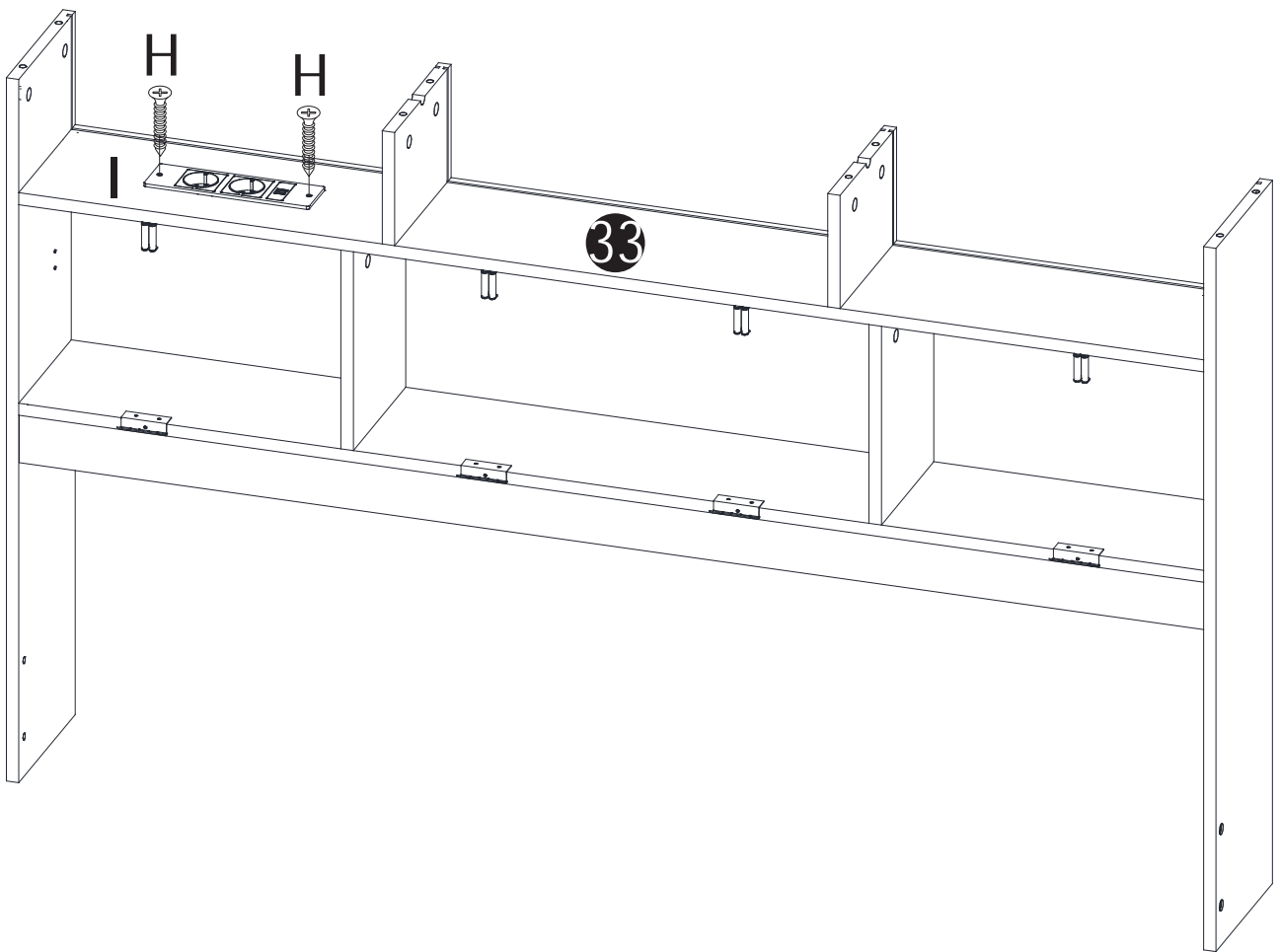
I	H	Q
		
1PC	2PCS	1PC





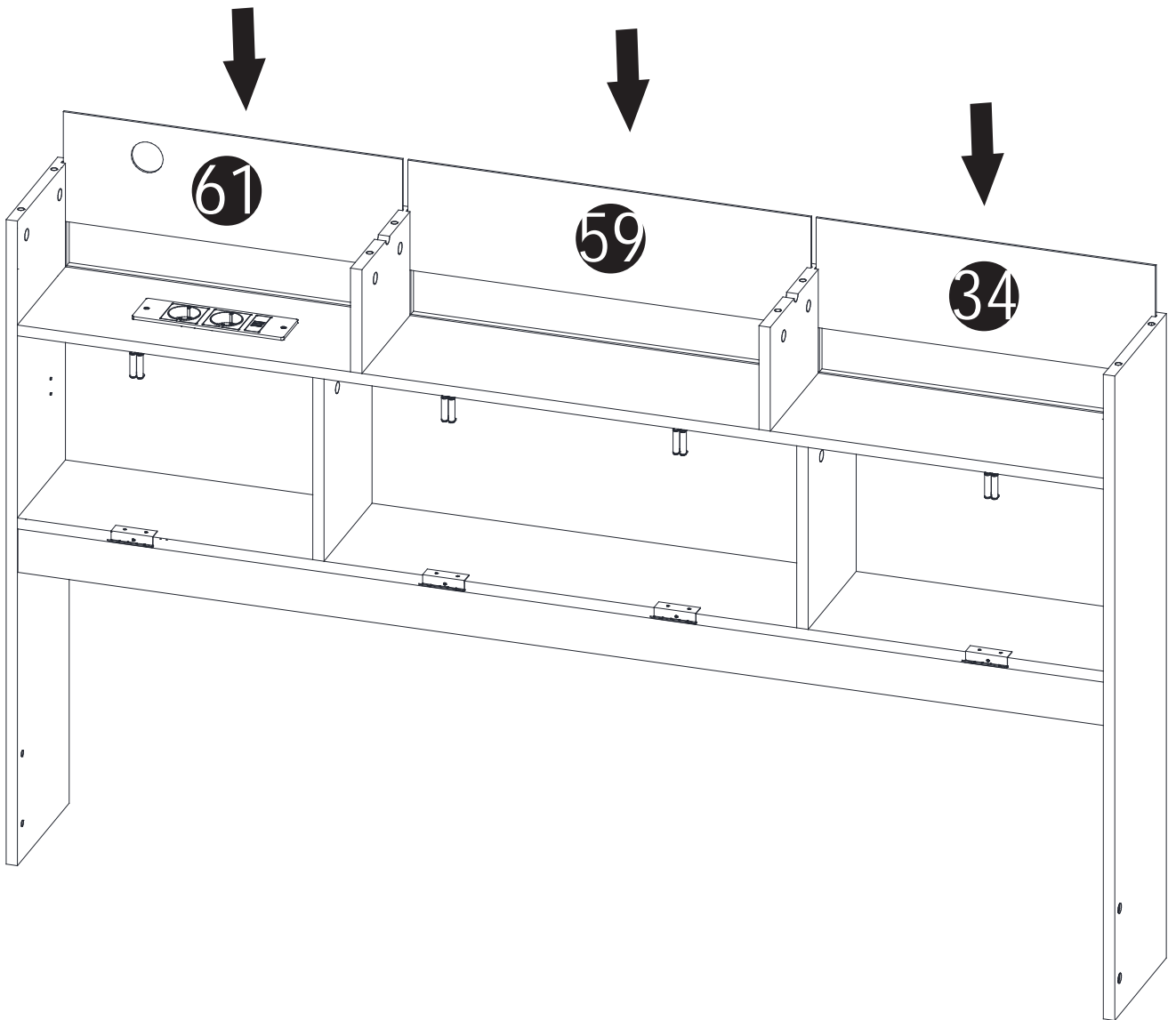

F	H
	
Φ4*30mm	Φ3.5*14mm(2PCS)

21

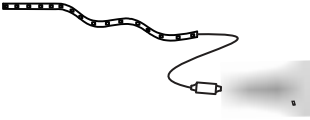

22

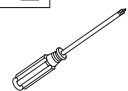
A6		A5		O		P		Q	
1PC		3PCS		8PCS		8PCS		1PC	



EN:Scan to download App control the Led light.

DE:Scannen, um die App zum Steuern des LED-Lichts herunterzuladen

FR:Scanner pour télécharger App contrôler la lumière Led.

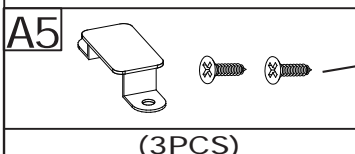
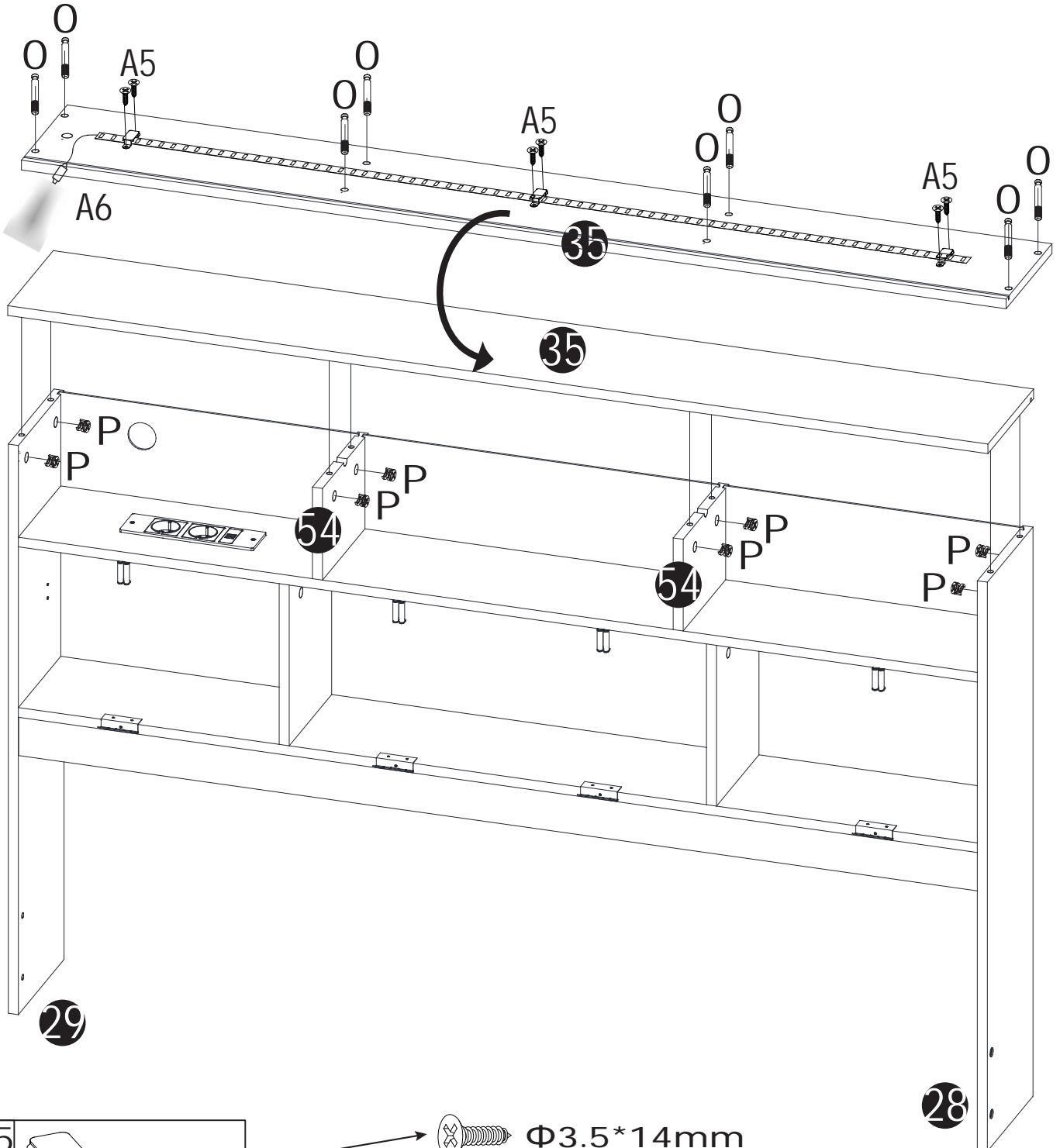

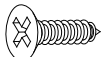

 $\Phi 3.5 * 14mm$

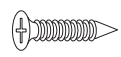
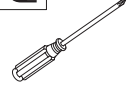

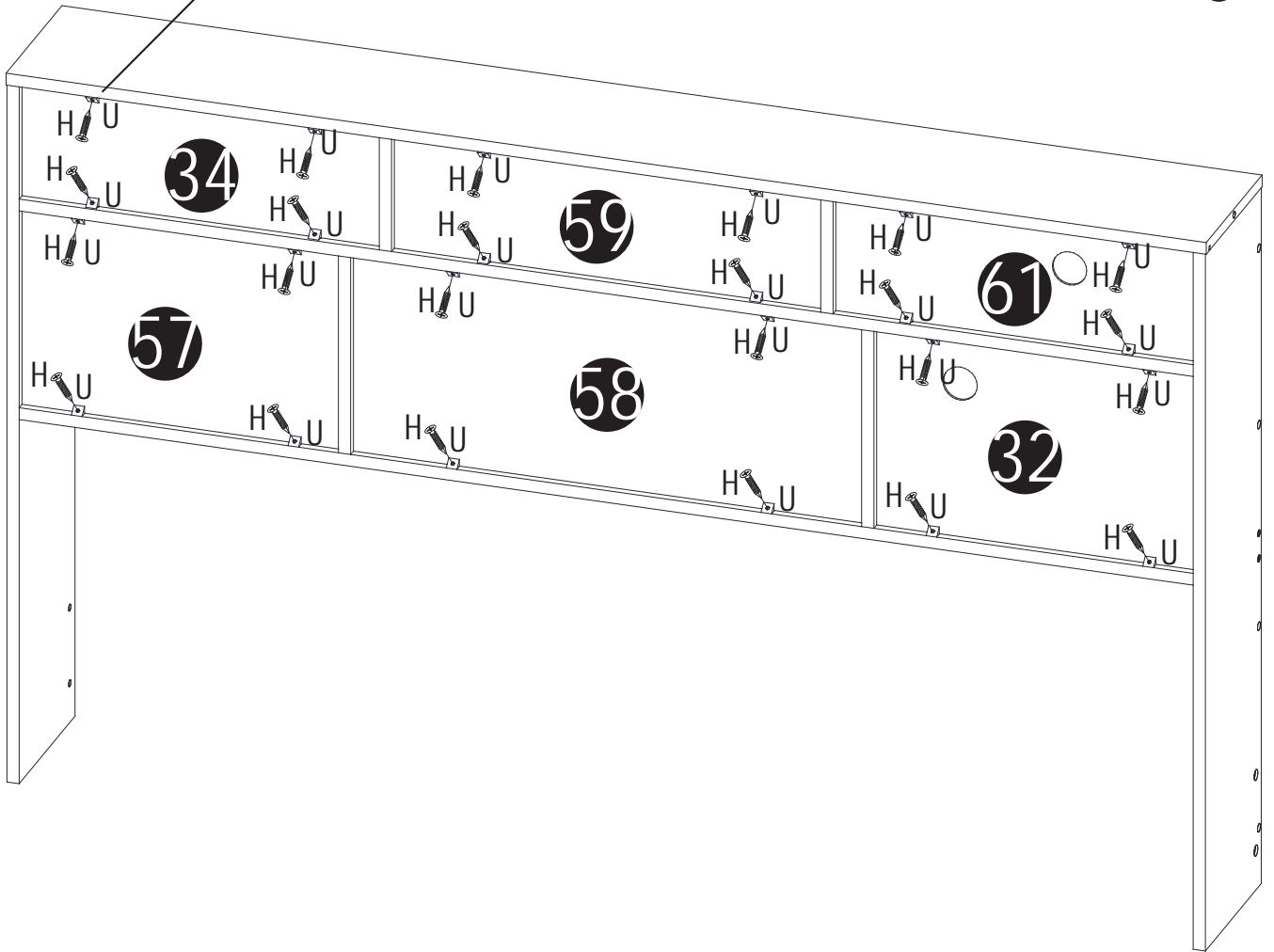
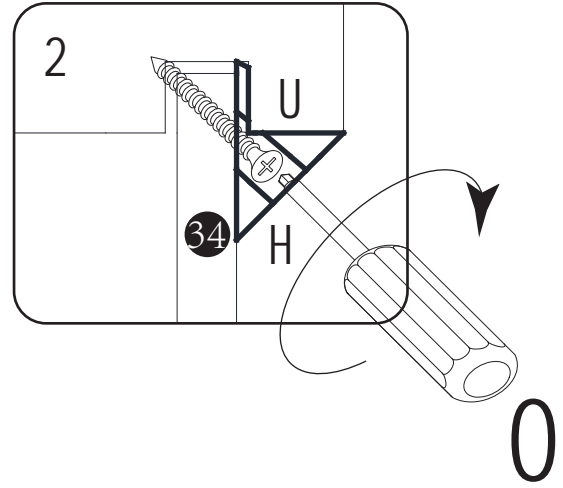
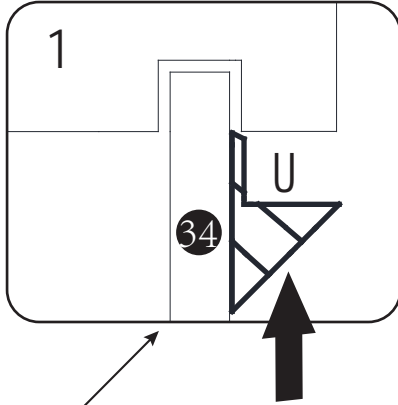
23

U 	H 	Q 
24PCS	24PCS	1PC



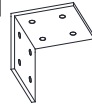

F 	H 
Φ4*30mm	Φ3.5*14mm(24PCS)

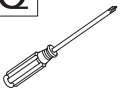
24

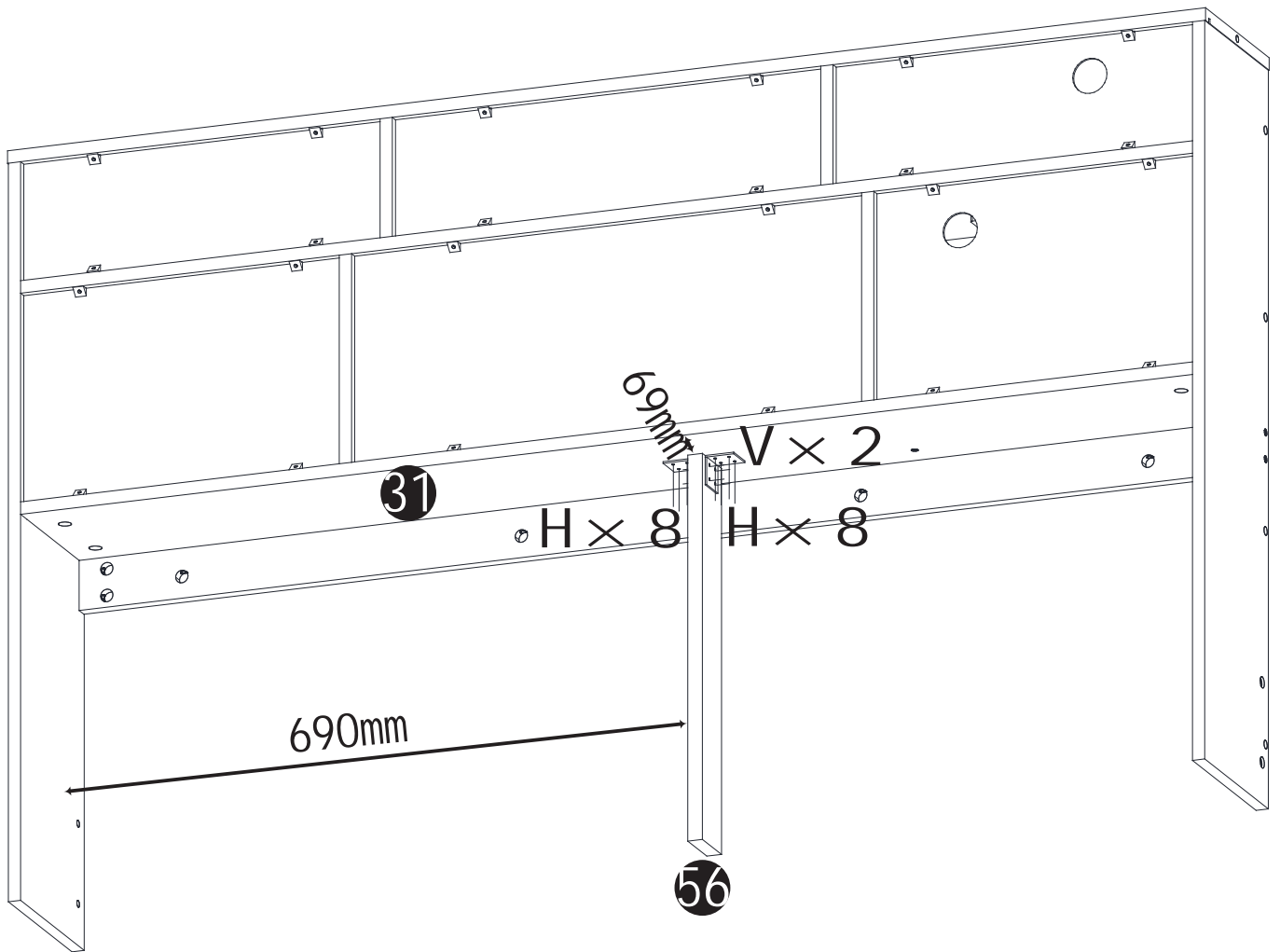
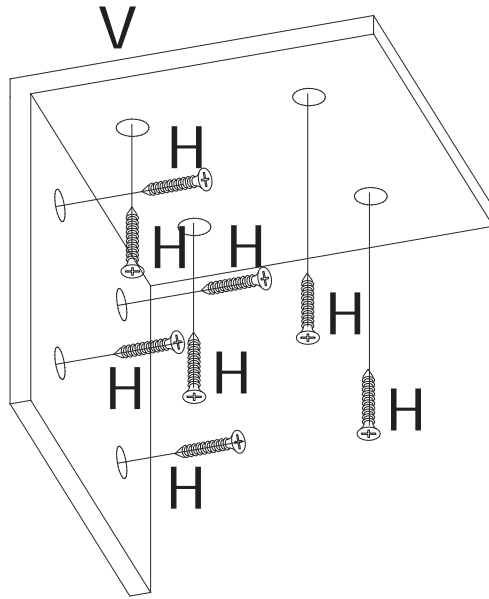
V		H		Q	
2PCS		16PCS		1PC	



F		H	
Φ4*30mm		Φ3.5*14mm(16PCS)	

25

H



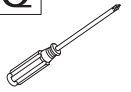

12PCS

Q



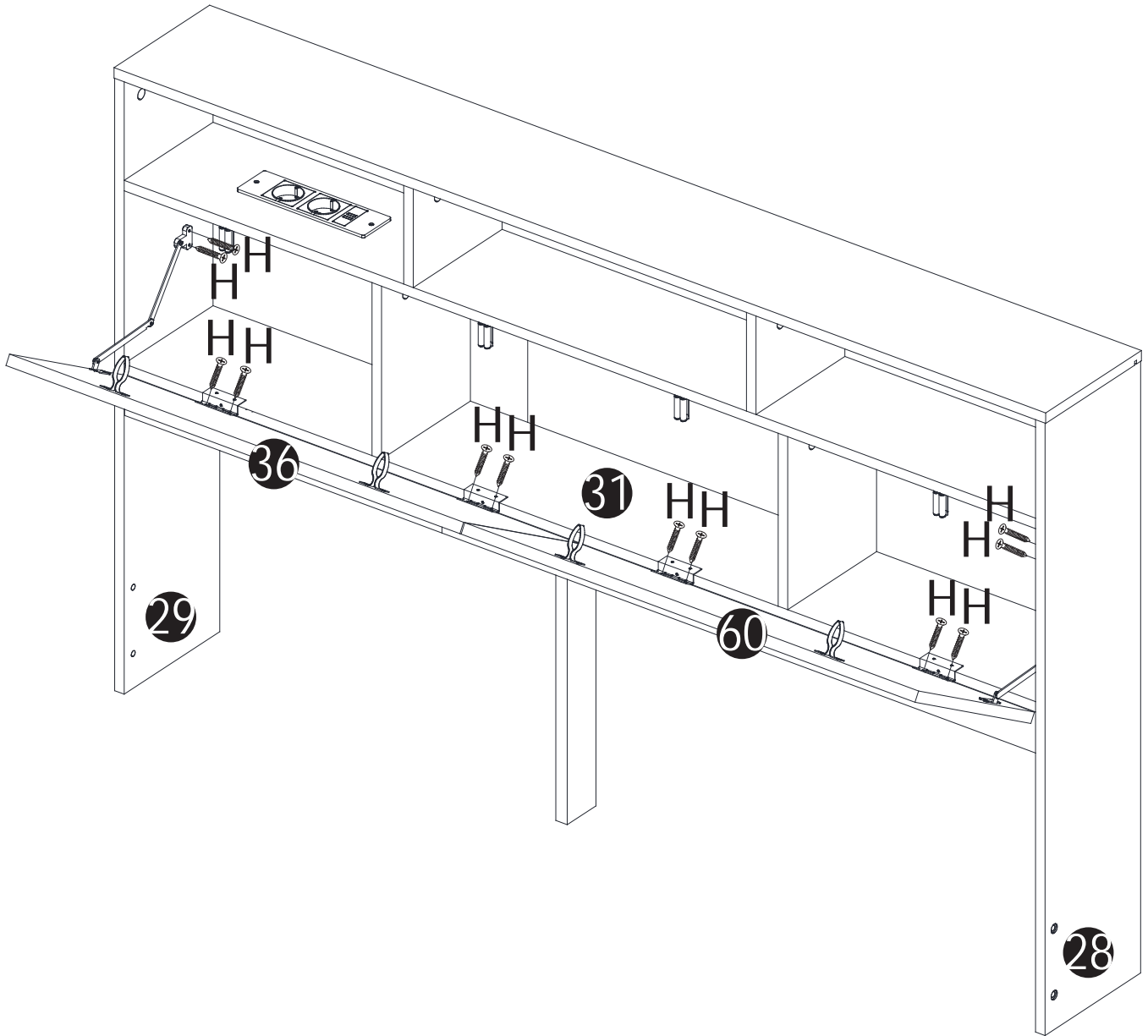



1PC





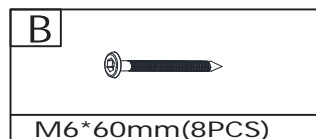
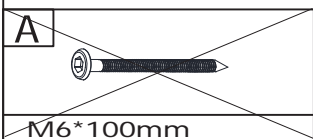
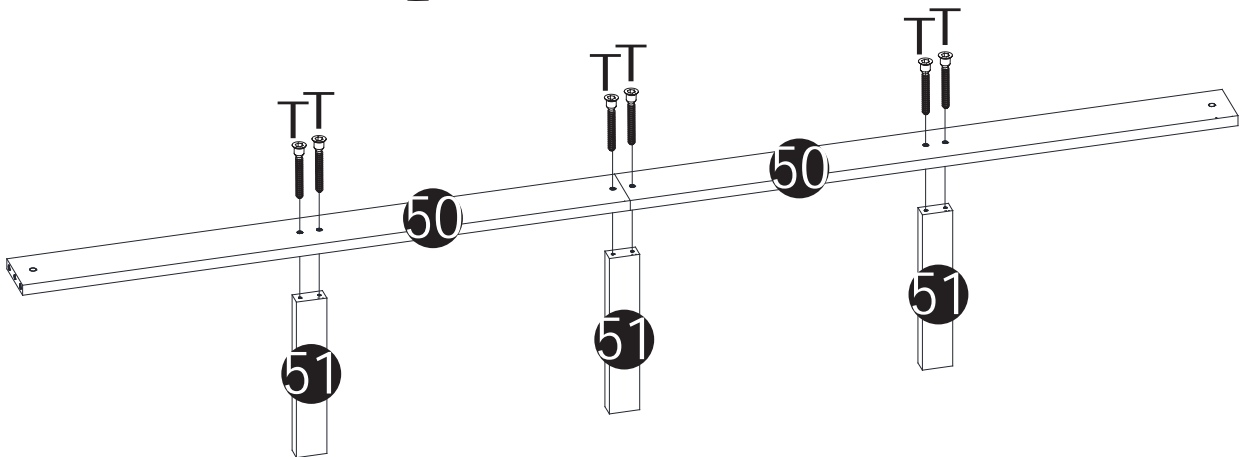
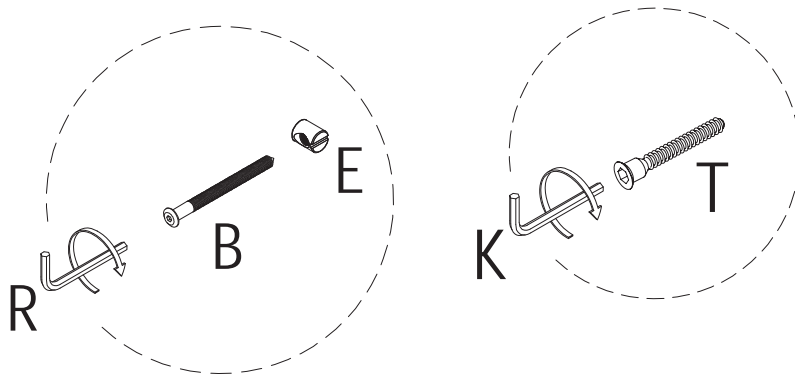
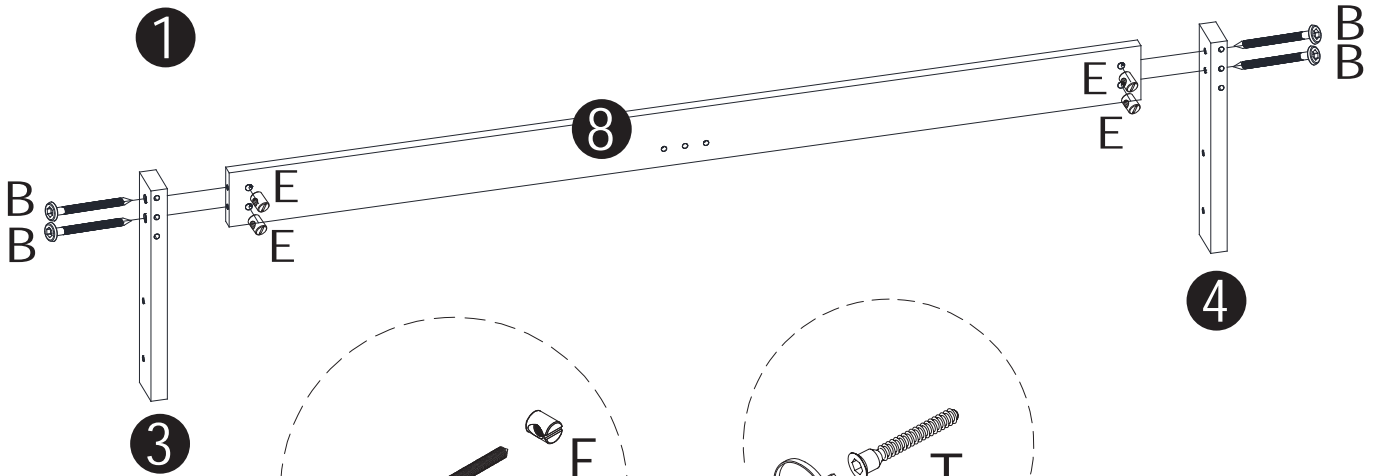
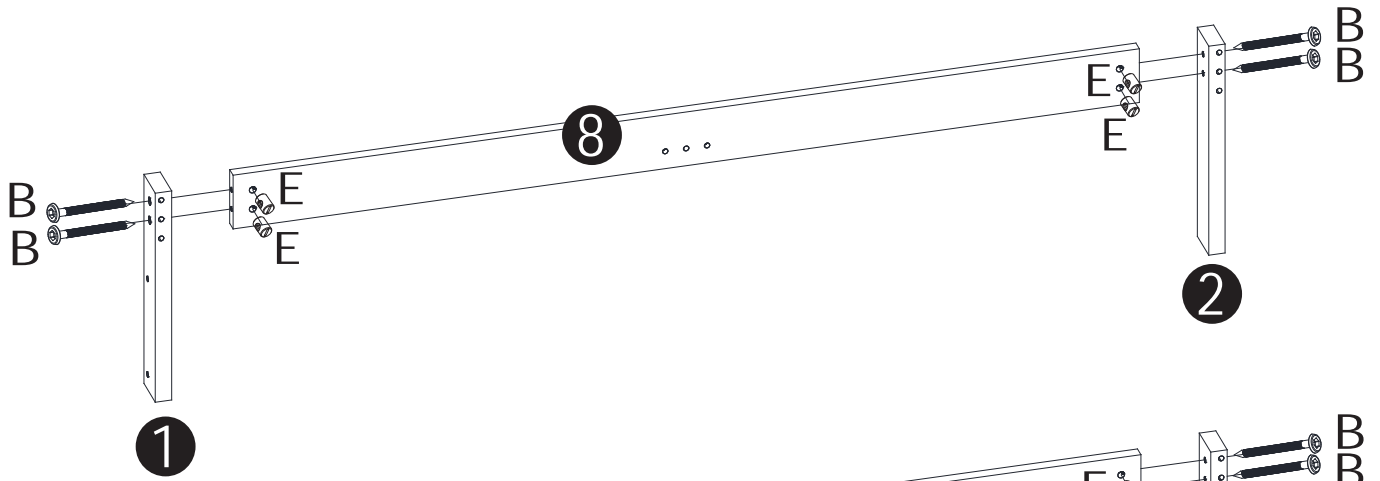

<p>F</p> 	<p>H</p> 
<p>Φ4*30mm</p>	<p>Φ3.5*14mm(12PCS)</p>

26

T	K	B	R	E
				
6PCS	1PC	8PCS	1PC	8PCS







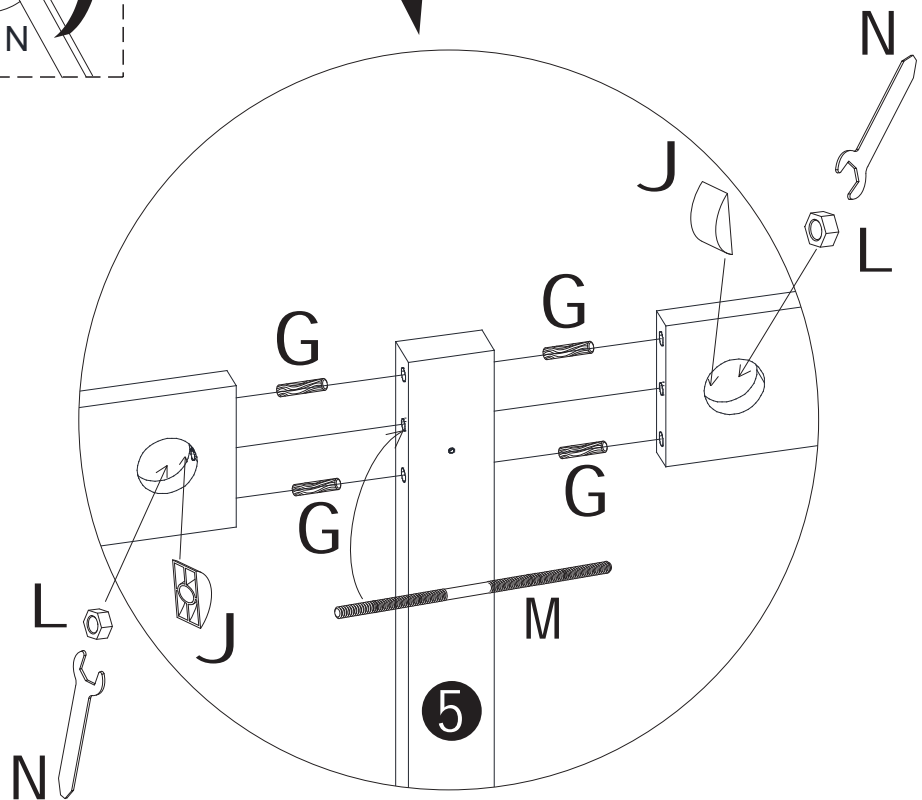
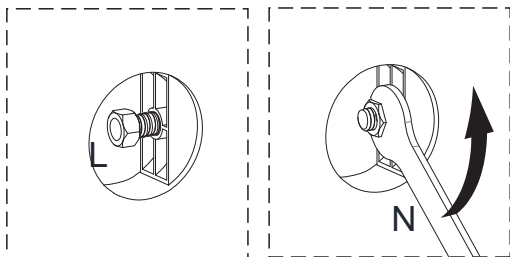
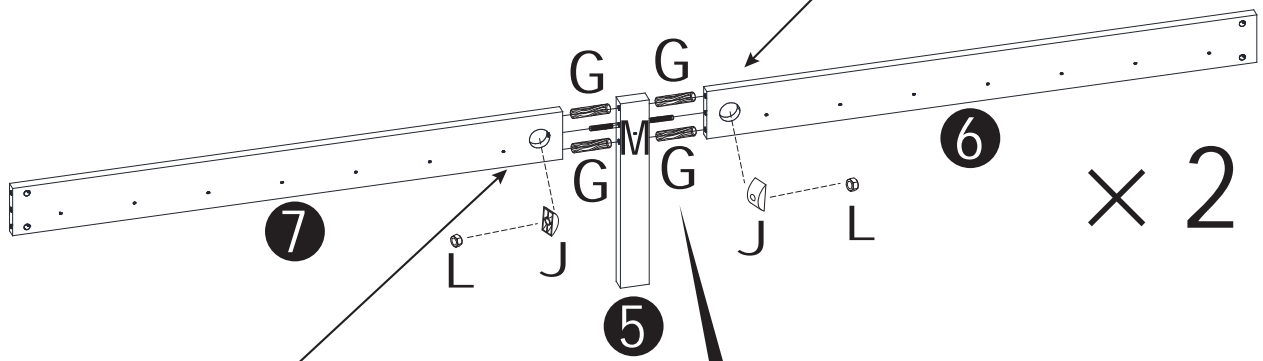
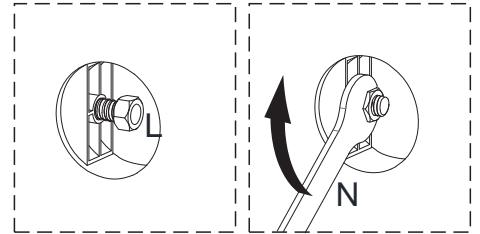

27

J	L	M	N	G
				
4PCS	4PCS	2PCS	2PCS	8PCS

Take note of the difference between the inner and outer sides of board No.05. When fully assembled, the inner side of board No.05 should be flush with No.06 and No.07.

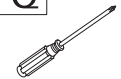

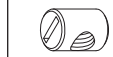

28

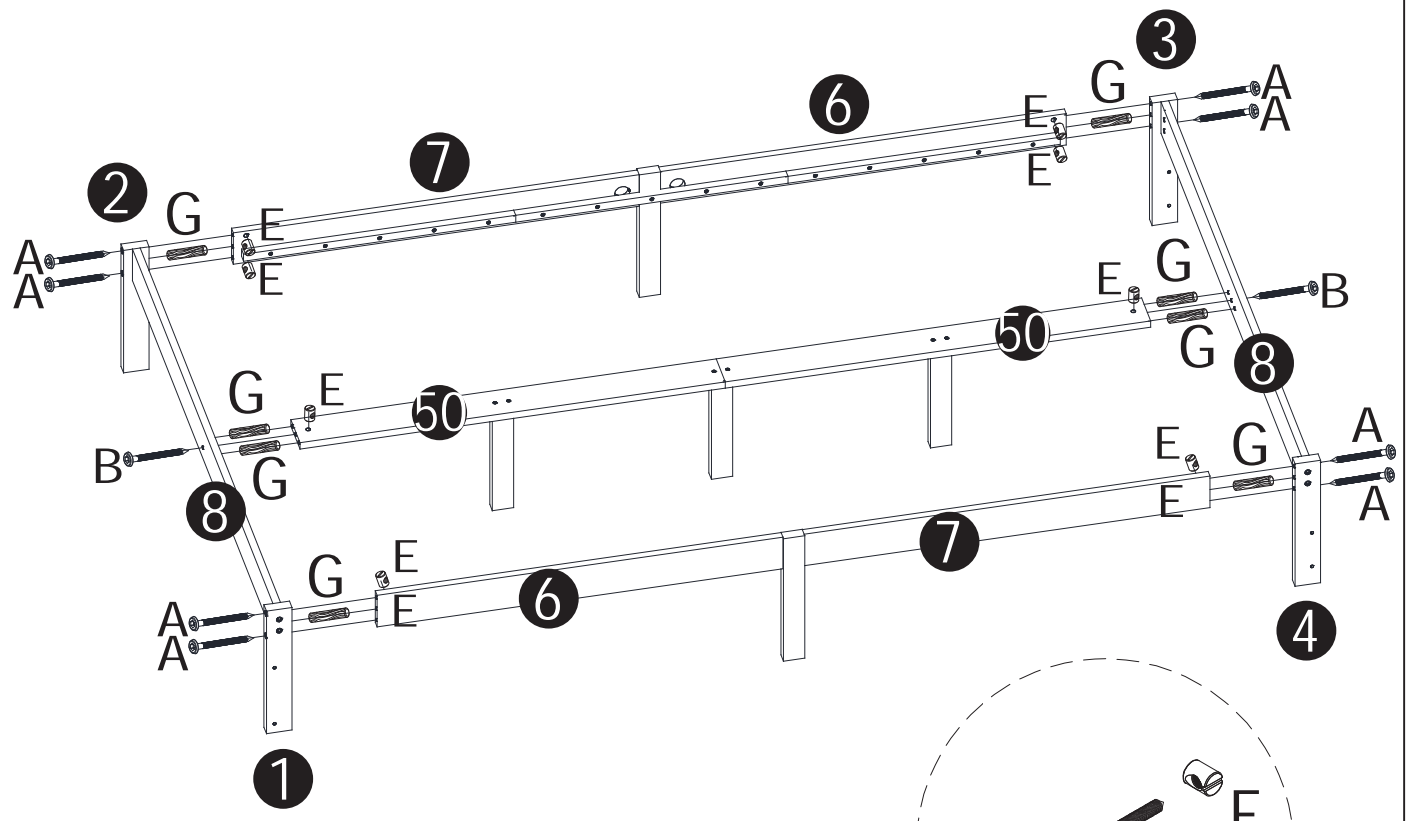
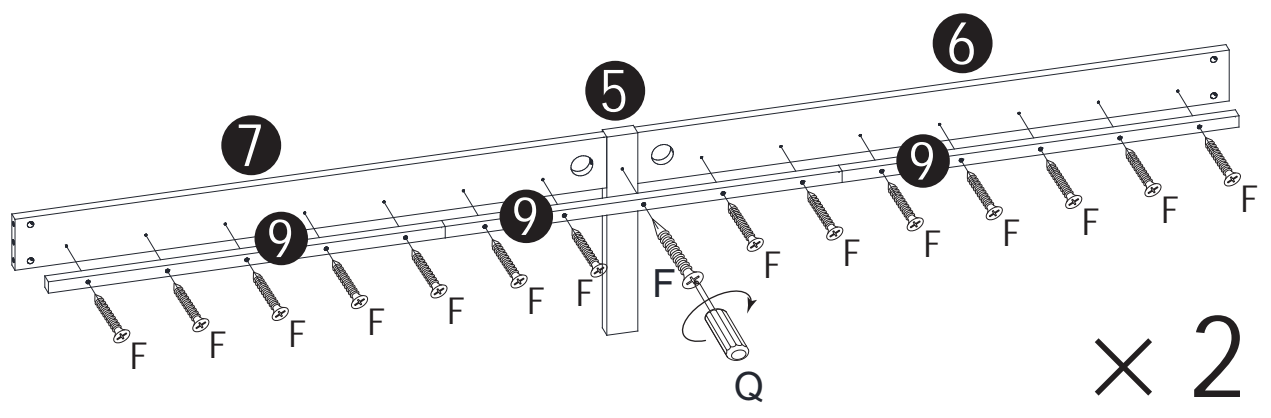
B	F	Q	G	R	E	A
						
2PCS	30PCS	1PC	8PCS	1PC	10PCS	8PCS

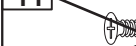



F		H	
Φ4*30mm(30PCS)		Φ3.5*14mm	

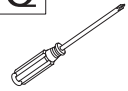

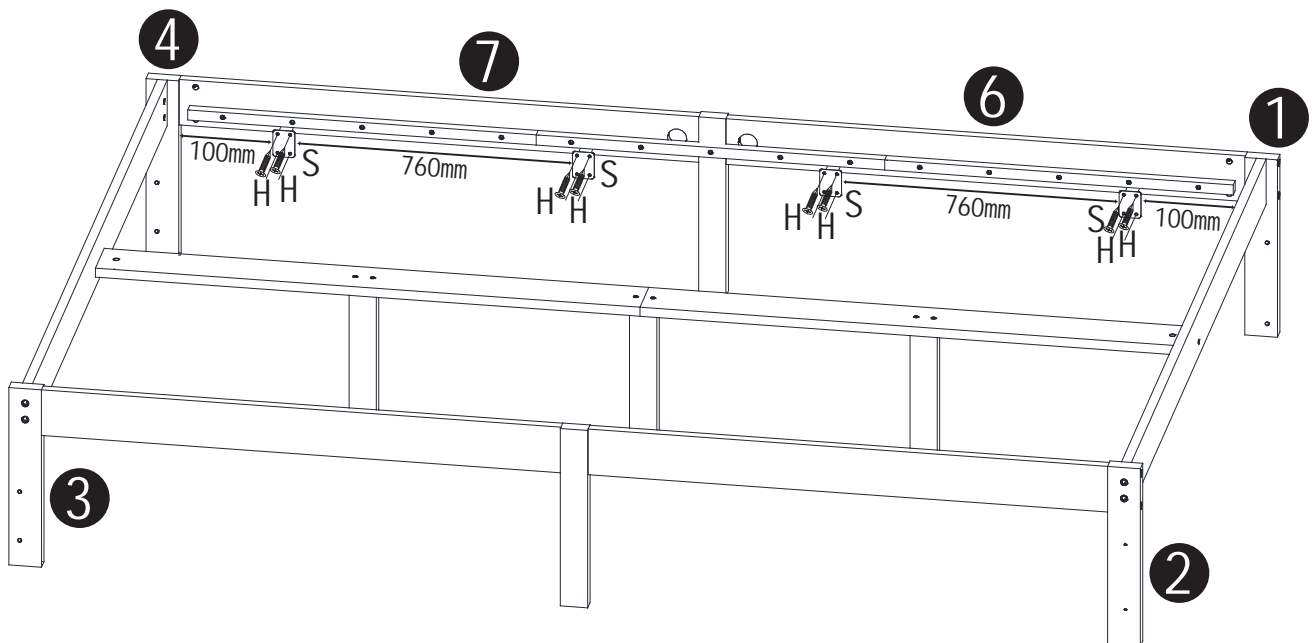
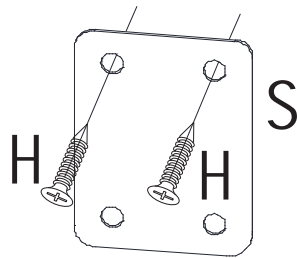
29

H	S	Q
		
8PCS	4PCS	1PC



	
Φ4*30mm	Φ3.5*14mm(8PCS)

30

R	D	C
		
2PCS	4PCS	4PCS

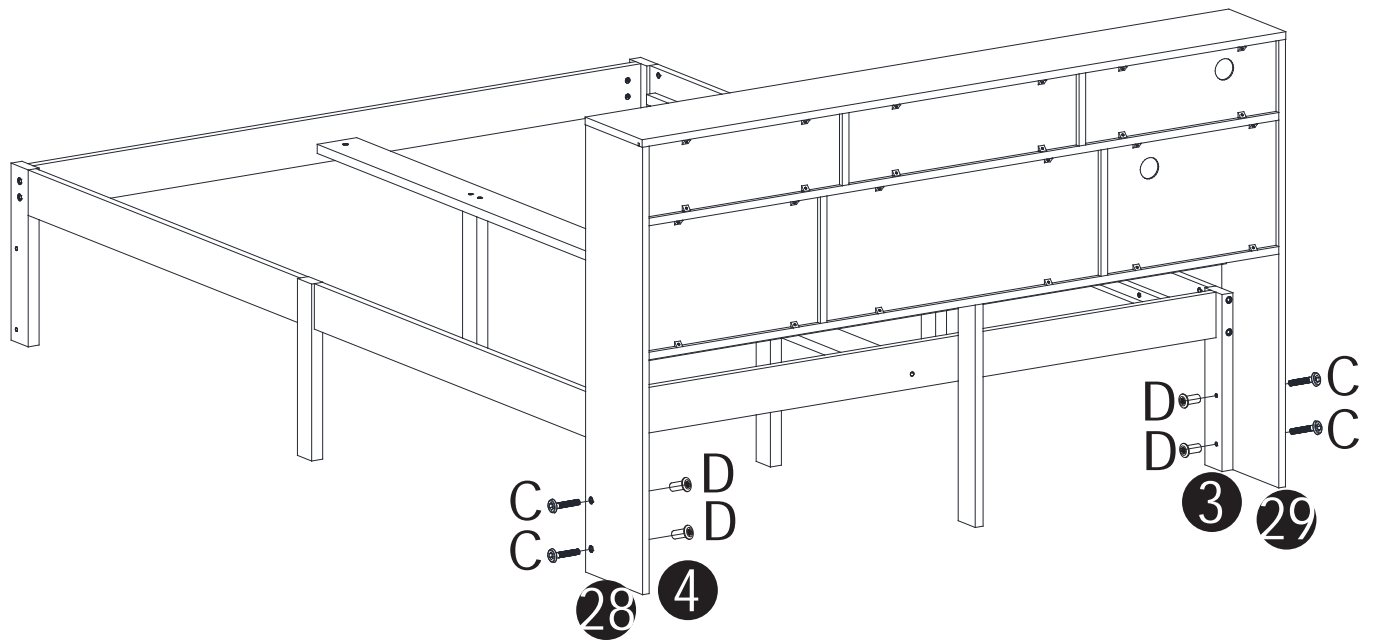
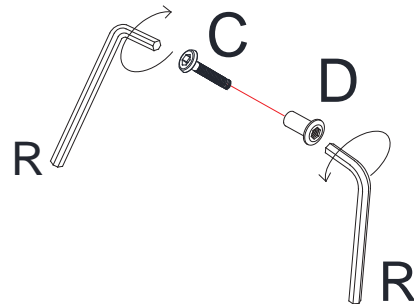

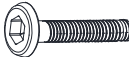
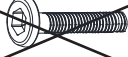

C		A4	
M6*35mm(4PCS)		M6*25mm	

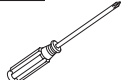
31

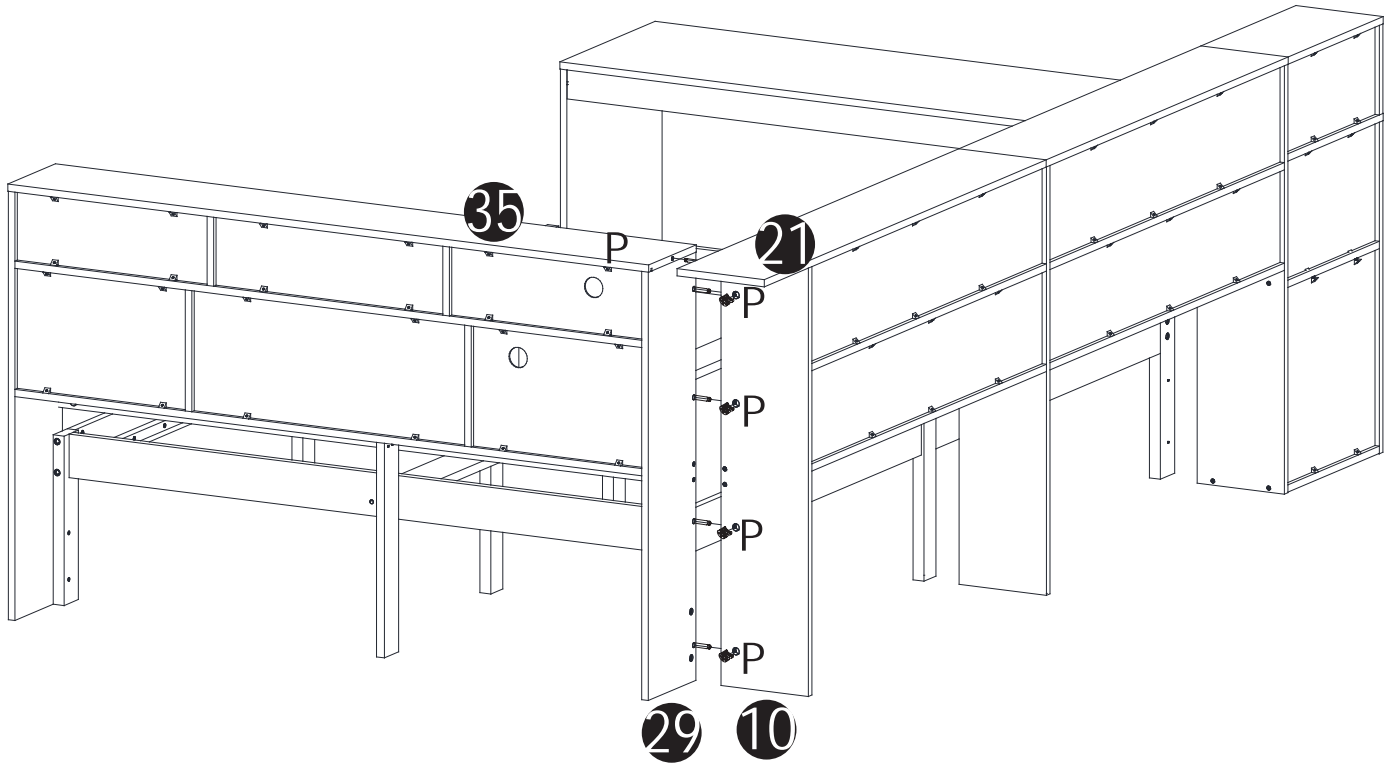
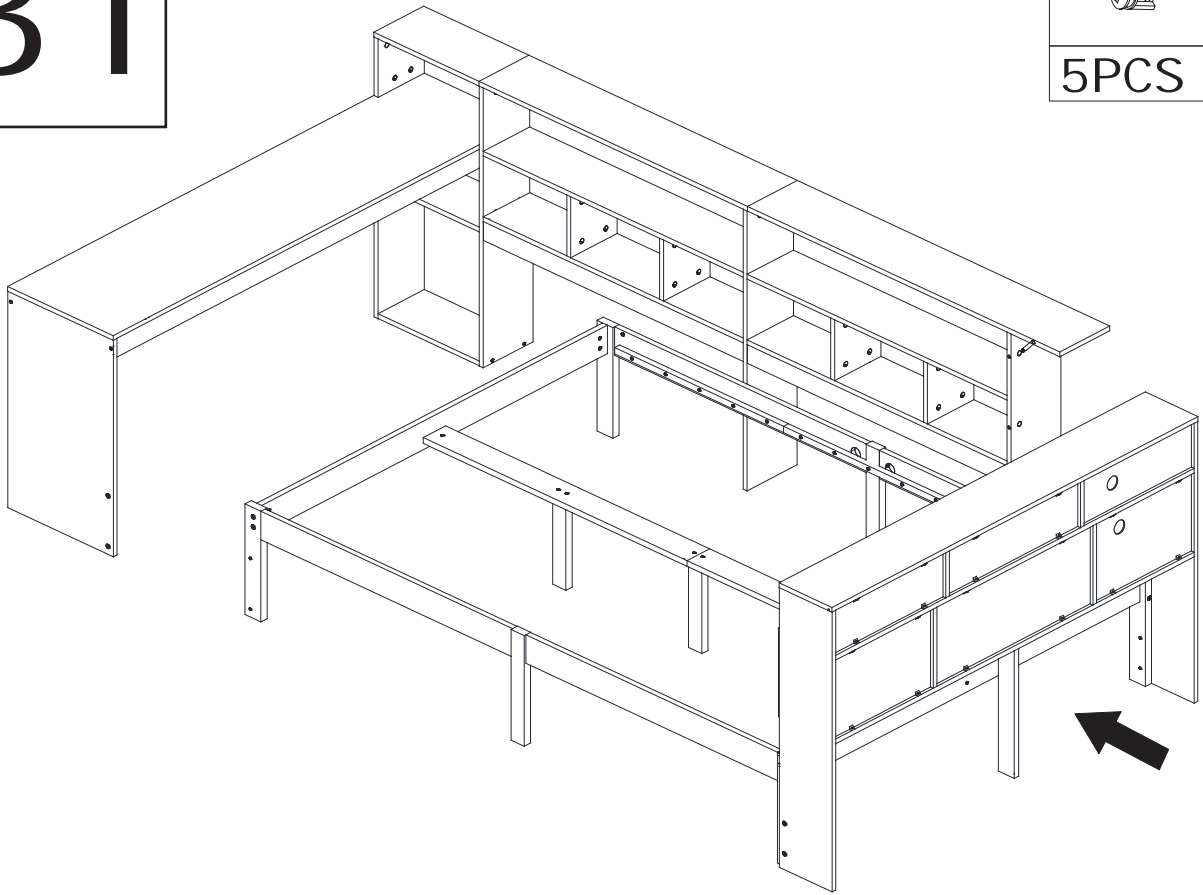

P	Q
	
5PCS	1PC



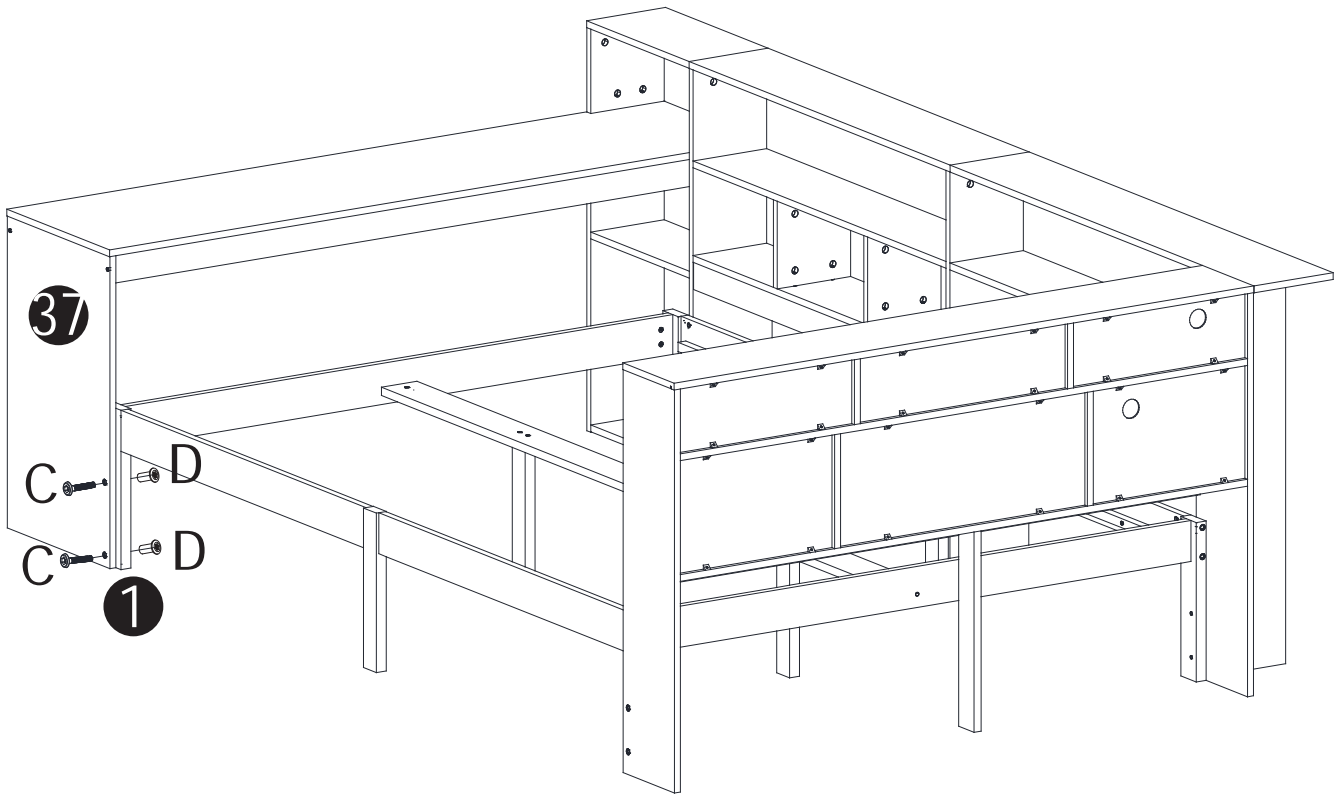
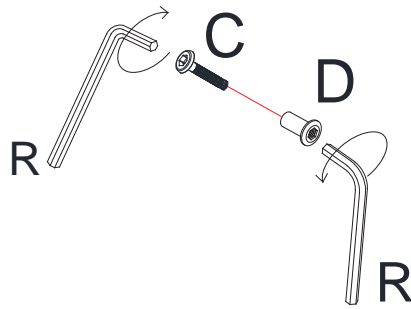

32

R	D	C
		
2PCS	2PCS	2PCS



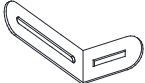

C		A4	
M6*35mm(2PCS)		M6*25mm	

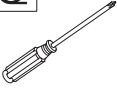
33

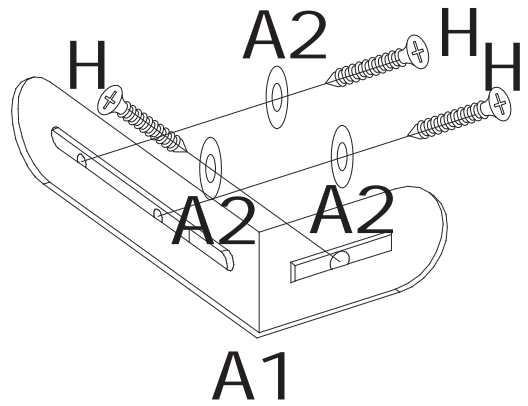
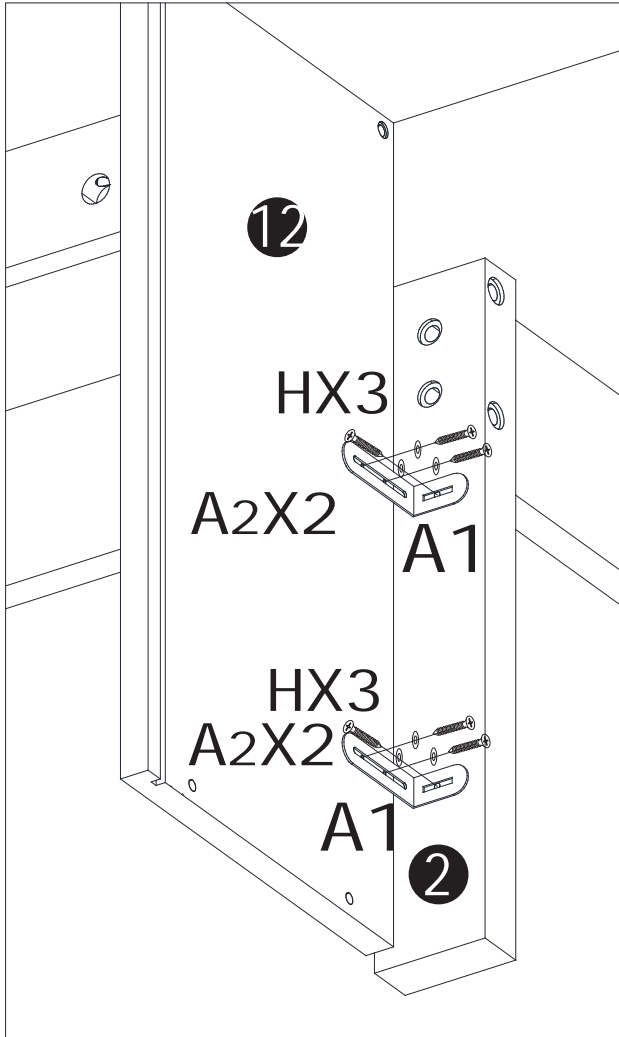
A1	H	A2	Q
			
2PCS	6PCS	6PCS	1PC





F	H
	
Φ4*30mm	Φ3.5*14mm(6PCS)

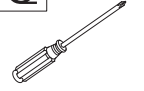

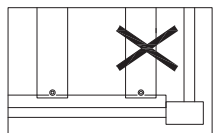
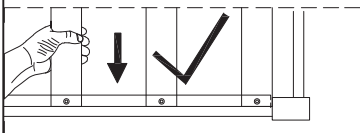
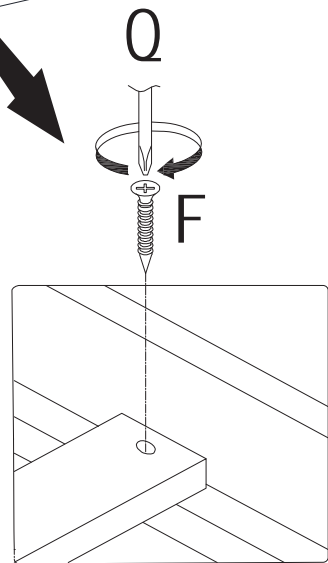
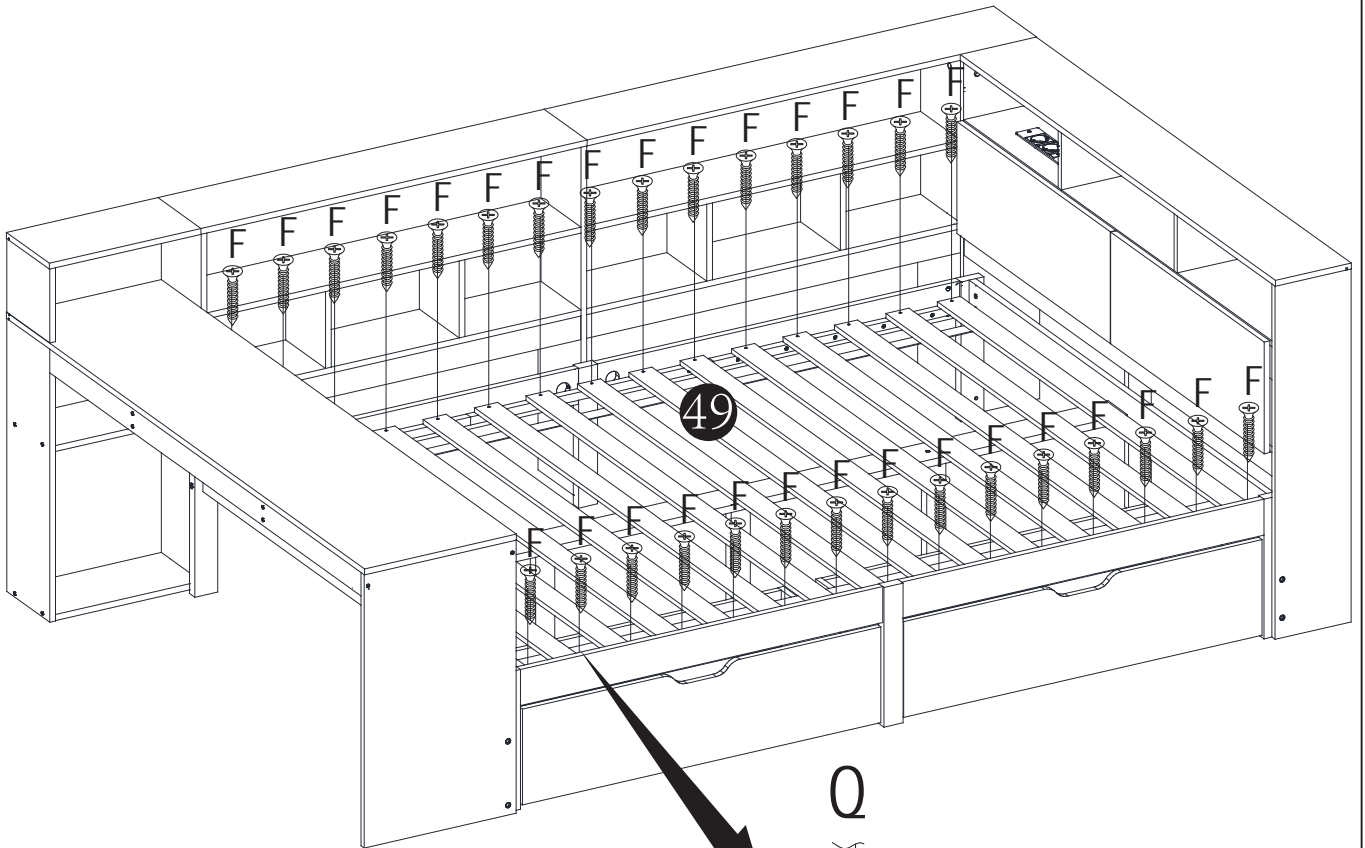

34

F	Q
	
30PCS	1PC



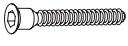
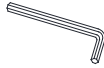

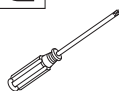
F		H	
Φ4*30mm(30PCS)		Φ3.5*14mm	

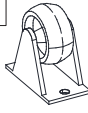
35

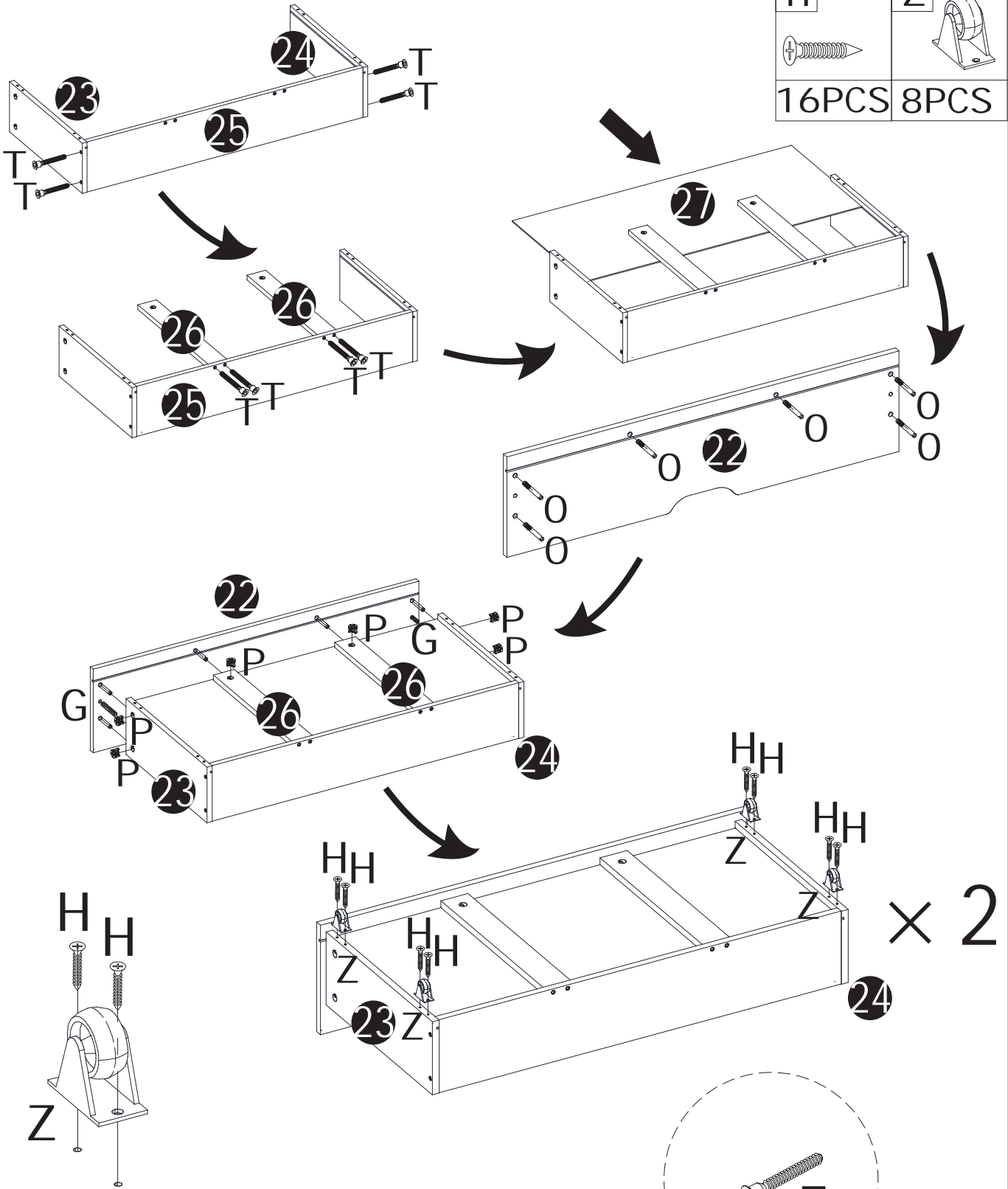
G	T	K	O	P	Q
					
4PCS	16PCS	1PC	12PCS	12PCS	1PC
				H	Z
					
				16PCS	8PCS



F	H
	
Φ4*30mm	Φ3.5*14mm(16PCS)

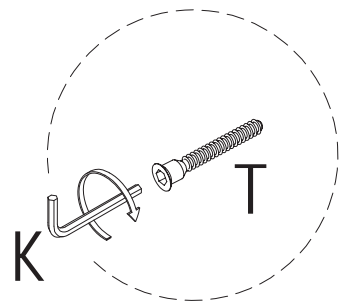



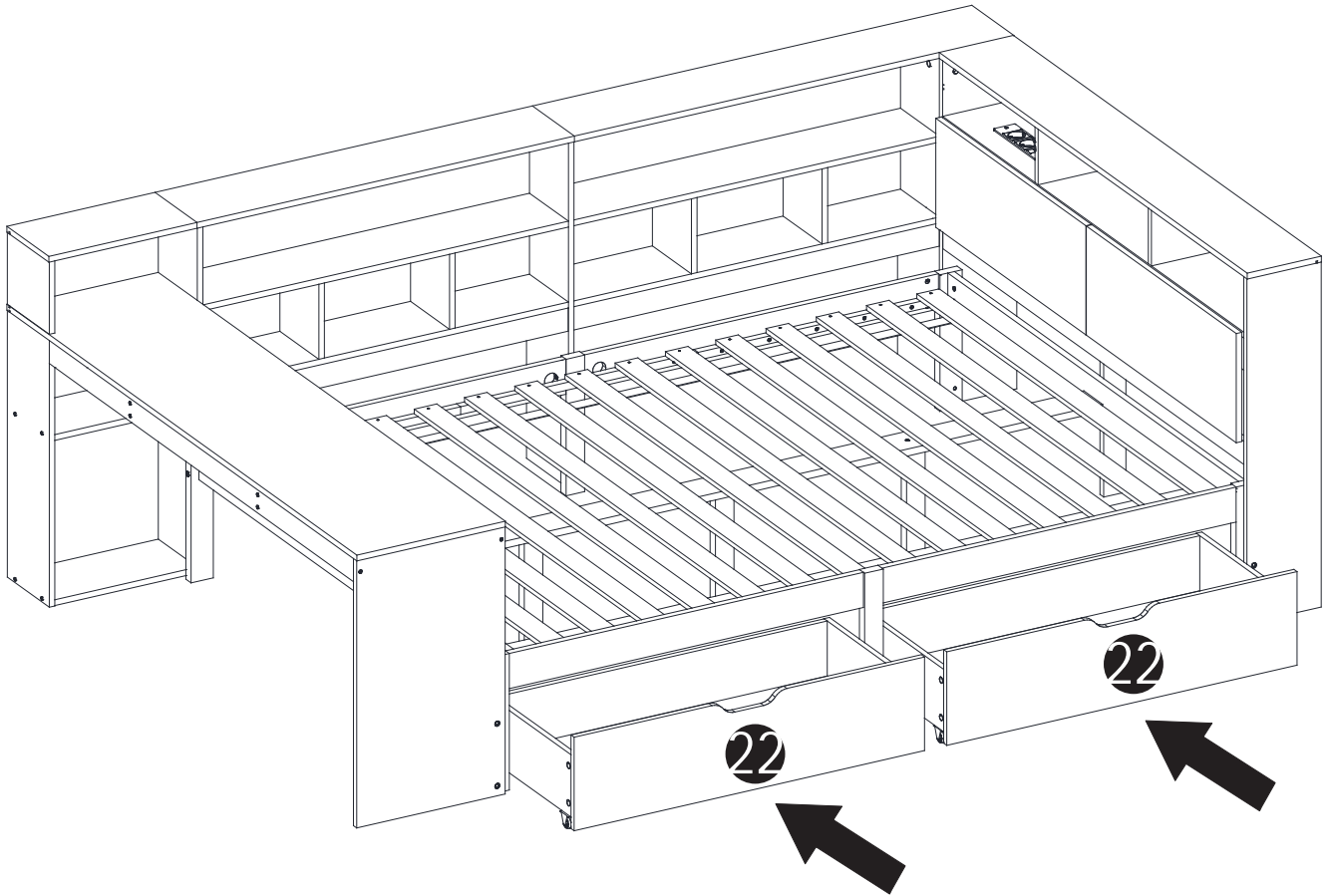



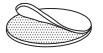
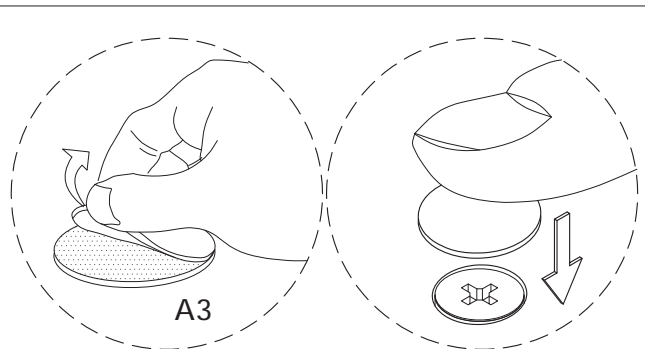
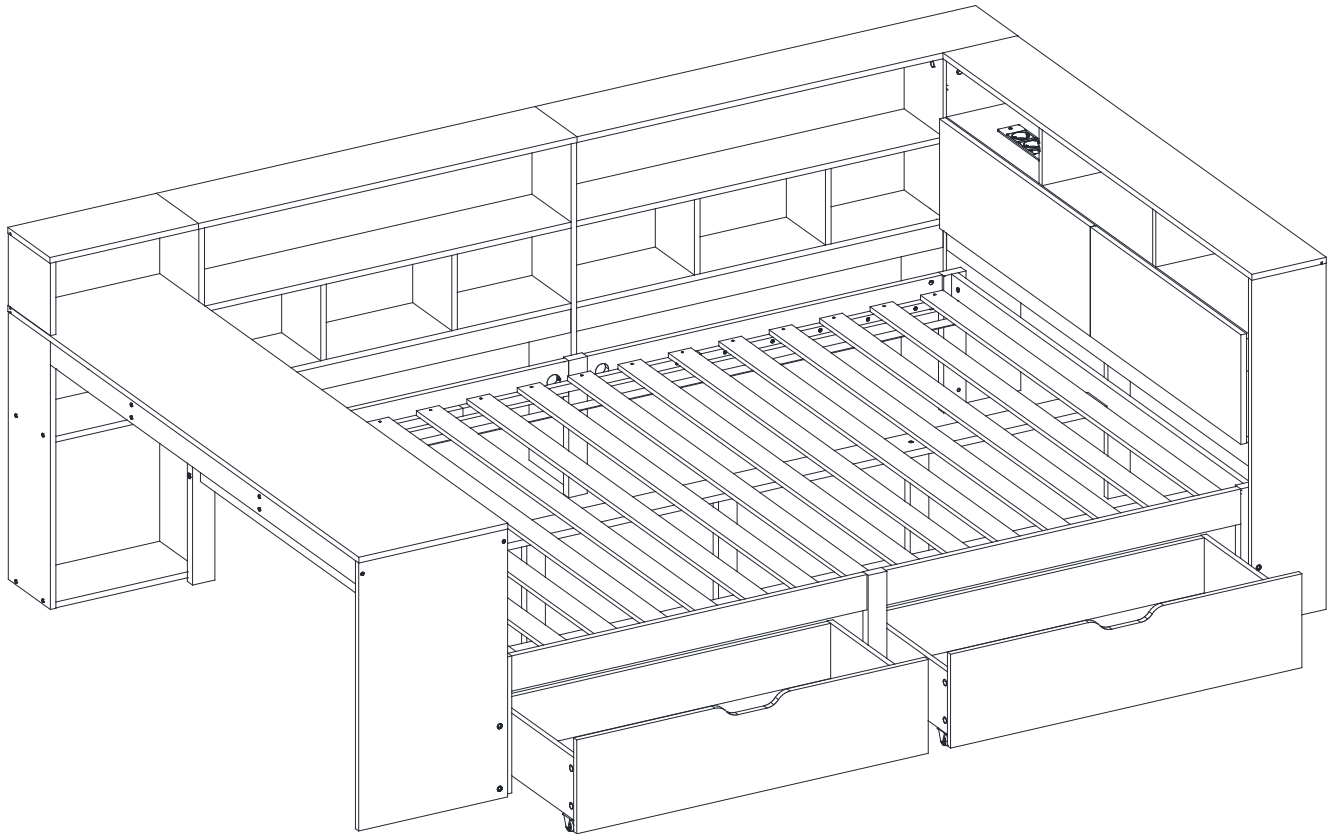





36



37

A3**176PCS****A3**

EN: In order to make the product more beautiful, please paste hardware G on the exposed holes.
DE: Um ein präzises produkt ästhetisieren zu können, fügen sie hardware G in eine entblöbte öffnung ein
FR: Afin de rendre le produit plus beau, s' il vous plaît coller le matériel G sur les trous exposés.
IT: Per rendere il prodotto più bello, incollare l' hardware G sui fori esposti.
ES: Con el fin de hacer el producto más hermoso, por favor pega hardware G en los agujeros expuestos

-  ←  **A3 X110**
P
-  ←  **A3 X44**
T
-  ←  **A3 X8**
A
-  ←  **A3 X2**
B
-  ←  **A3 X6**
C
-  ←  **A3 X6**
D

LotusLantern APP Manual

1. Software Overview

1.1 Overview

LotusLantern is a mobile APP to control LED strip by both Apple and Android phones. The traditional control ways like infrared, 433MHz, 2.4GHz and others old wired ways will be replaced by mobile phone control way with convenient, powerful and scalable features.

Through this mobile APP, you can not only control the color, brightness and color temperature of the LED strips but also set up all kinds of fancy flash mode; Also this APP can change the light of the LED strip according to the rhythm of the music. This APP can set and control several LED strips through Bluetooth and the operation is very simple, easy to learn and easy to use.

1.2 Features

- Adjust color LED strips with 60,000 colors to change color and brightness and adjust monochrome LED strips to change brightness and color temperature
- Play music or turn on a sound playback device, you can let the light change the color and brightness with the rhythm of music, the music rhythm beautiful
- Inside multiple setting mode for color change and control LED strips without mobile
- Long distance control with omni-directional antenna, and many-to-many group control mode
- Once the connection is successful, connect automatically next time

1.3 Performance

LotusLantern APP is easy for use as well as great compatible for all kinds of smart phones: After the actual test of hundreds of mobile phones verification, the compatibility is above 95% of mobile phones in the market. APP is small and convenient, it consumes less system resources, so the requirements of the mobile configuration are low. Control delay is small, the operation feel good, light control is smooth with people's visual sense.

2. Operating Environment

This APP program requires phones of system above Android 4.3 and iOS 8.0. Mobile phone configuration is not limited.

3. Instructions

Note: Android version and iOS version download and use the same method, here in the Android version as an example.

3.1 APP Download

Scan the QR code

iOS and Android systems can download the "LotusLantern" APP by scanning the QR code. Open the browser or other tools with "Scan QR code" function, scan the "LotusLantern" QR code as below:



3.2 App Operation

(1) Click on the LotusLantern APP icon, enter the APP page:



(2) After entering the APP interface, if Bluetooth is not enabled, "an application wants to enable the Bluetooth function of this device." Click [Allow]

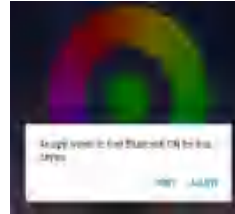

(3) switch to color and brightness interface:

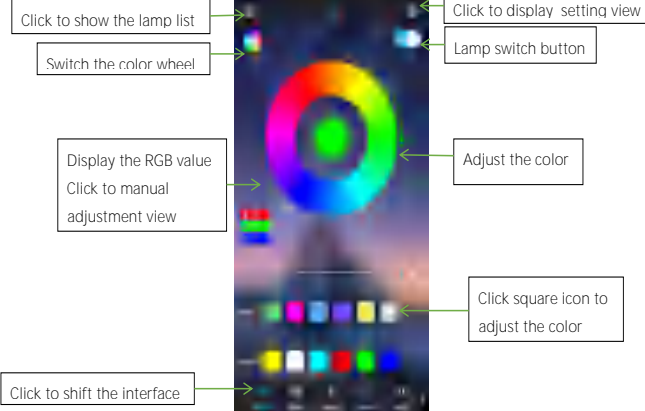

(4) click to show the lamp list, view lamp list:

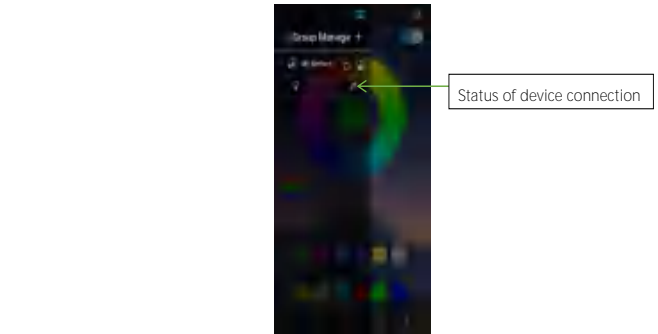

(5) Click to RGB manual adjustment view:

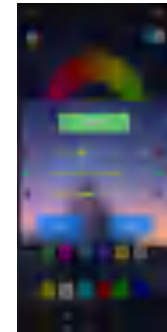

(6) switch to the mode interface:

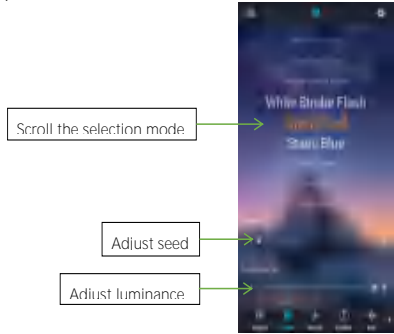

(7) switch to the music rhythm interface:

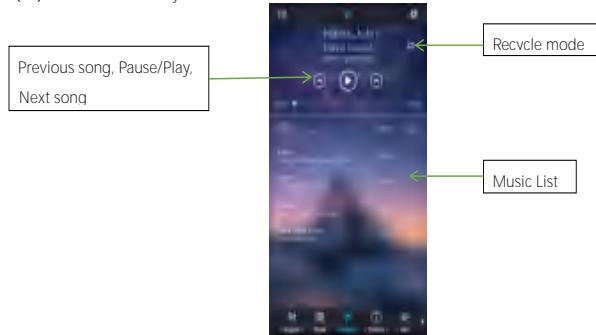

(8) Switch to the online music interface:

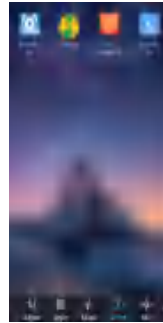

(9) Switch to the microphone rhythm interface:

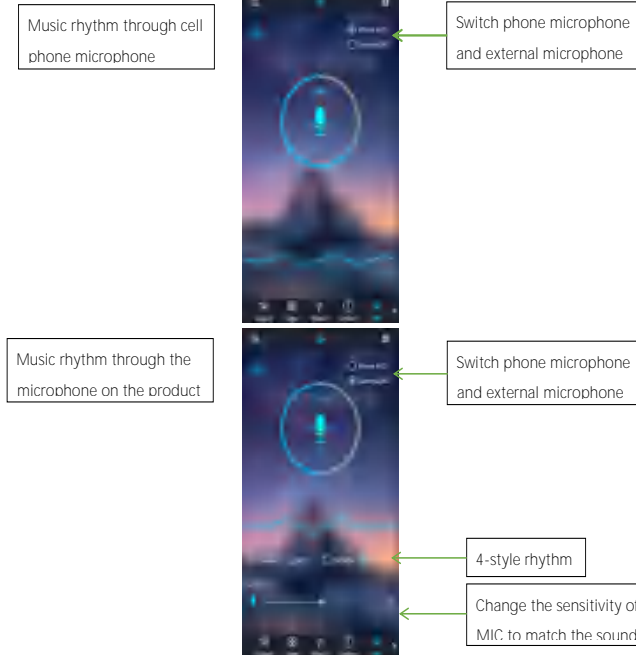

(10) Switch to the schedule interface:



(11) Switch to the modify pin sequence interface:

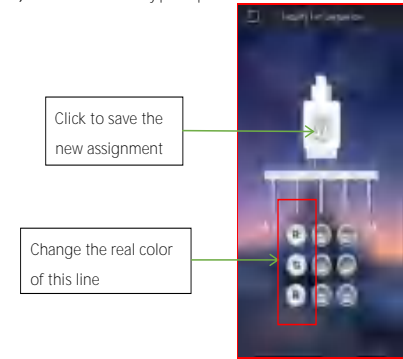

Verification of Compliance

Certificate No. : LBTR240314130R-C

Applicant : QingDao ChengKong Electrical-Auto Co., Ltd

Address : No.147 Xining Road, Zhuhai Community, Huangdao District, Qingdao , Shandong ,China

Manufacturer : QingDao ChengKong Electrical-Auto Co., Ltd

Address : No.147 Xining Road, Zhuhai Community, Huangdao District, Qingdao , Shandong ,China

Sample Name : LED STRIPT LIGHT

Sample Model : L-50-30D,L-50-18D,L-50-60D,L-50-120D,L-3528-30D,L-3535-30D,L-3014-30D

Test Standard : IEC62321-1:2013 IEC62321-3-1:2013
IEC62321-4:2013/AMD1:2017 IEC62321-5:2013
IEC62321-6:2015 IEC62321-7-1:2015
IEC62321-7-2:2017 IEC62321-8:2017

The EUT described above has been consolidated by us and found in compliance with the council RoHS 2.0 Directive 2011/66/EU and its subsequent amendments Directive (EU)2015/863.

The cortificate applies to the tested sample above montioned only and shall not imply an assessment of the whole production. It is only valid in connection with the test report number. LBTR240314130R



Signed for and on behalf of

Jacob Su
A red circular seal with the text 'SHENZHEN LABTEST TECHNOLOGY LABORATORY LTD.' around the perimeter and 'AUTHORIZED SIGNATORY' in the center. A signature is written across the seal.

Approved Signatory

Apr.23,2024

This report shall not be altered, increased or deleted. The results shown in this test report refer only to the sample(s) tested. Without written approval of Labtest, this test report shall not be copied except in full and published as advertisement. Labtest Chemical Lab.

Shenzhen Labtest Technology Laboratory Ltd.

901-12, Block 1, No.9 Jinxiu Middle Road, Laokeng Community, Longtian Street, Pingshan District, Shenzhen, Guangdong, China.
<http://www.clabtest.com>, Tel:+86-0755-23721065, E-mail:harvey@labtest.ec



This certificate is responsible for testing sample only.
Please refer to this corresponding test report to get testing process and data.

CERTIFICATE

ATTESTATION Certificate of Compliance

Technical file of the company mentioned below has been inspected and audit has been completed successfully

The EMC Directive 2014/30/EU has been taken as references for these processes.

Certificate's Holder : QingDao ChengKong Electrical-Auto Co., Ltd.
Address : Room 5-402, No.147 Xining Road, Zhuhai Community, Huangdao District, Qingdao, Shandong, China
Manufacturer : QingDao ChengKong Electrical-Auto Co., Ltd.
Address : Room 5-402, No.147 Xining Road, Zhuhai Community, Huangdao District, Qingdao, Shandong, China
Product Name : LED STRIPT LIGHT
Product Model (S) : L-50-30D,L-50-18D,L-50-60D,L-50-120D,L-3528-30D,L-3535-30D,L-3014-30D
Trade Mark : Roozmausy
Related Directive : 2014/30/EU
EN 55015: 2014+A1: 2017+A2:2019
Related Standards : EN 61547: 2019
EN 61000-3-2: 2016+A2:2019
EN 61000-3-3: 2018
Certificate Number : HK2504211326L
Report No. : HK2504211326-1LT
Registration Date : Jun. 04, 2025



The information of the certificate can be checked through www.cer-mark.com. The CE mark which is shown on the certificate can only be used under the conditions that the products complete with all of the relevant Directives of CE Declaration of Conformity. The Manufacturer should be responsible for the internal production control so that the products complied with the essential requirements of the above mentioned Directive(s). Certificate holder must notify all changes to the original certification laboratory of HUAKE.



Shenzhen HUAKE Testing Technology Co., Ltd.

Add.: 1-2/F., Building B2, Junfeng Zhongcheng Zhizao Innovation Park, Heping, Fuhai Street, Bao'an District, Shenzhen, Guangdong, China
Tel.: +86-755-2302 9901 Http:// www.cer-mark.com Postcode: 518103 E-mail: service@cer-mark.com



This certificate is responsible for testing sample only.
Please refer to this corresponding test report to get testing process and data.

CERTIFICATE

ATTESTATION Certificate of Compliance

Technical file of the company mentioned below has been inspected and audit has been completed successfully

The Low Voltage Directive 2014/35/EU has been taken as references for these processes.

Certificate's Holder : QingDao ChengKong Electrical-Auto Co., Ltd.

Address : Room 5-402, No.147 Xining Road, Zhuhai Community, Huangdao District, Qingdao, Shandong, China

Manufacturer : QingDao ChengKong Electrical-Auto Co., Ltd.

Address : Room 5-402, No.147 Xining Road, Zhuhai Community, Huangdao District, Qingdao, Shandong, China

Product Name : LED STRIPT LIGHT

Product Model (S) : L-50-30D,L-50-18D,L-50-60D,L-50-120D,L-3528-30D,L-3535-30D,L-3014-30D

Trade Mark : Roozmausy

Related Directive : 2014/35/EU

Related Standards : IEC/EN 60598-1
IEC/EN 60598-2-x
IEC/EN 61347-1
IEC/EN 61347-2-13

Certificate Number : HK2504210633L

Report No. : HK2504210633-LT

Registration Date : Jun. 04, 2025



The information of the certificate can be checked through www.cer-mark.com. The CE mark which is shown on the certificate can only be used under the conditions that the products complete with all of the relevant Directives of CE Declaration of Conformity. The Manufacturer should be responsible for the internal production control so that the products complied with the essential requirements of the above mentioned Directive(s). Certificate holder must notify all changes to the original certification laboratory of HUAKE.



Shenzhen HUAKE Testing Technology Co., Ltd.

Add.: 1-2/F., Building B2, Junfeng Zhongcheng Zhizao Innovation Park, Heping, Fuhai Street, Bao'an District, Shenzhen, Guangdong, China
Tel.: +86-755-2302 9901 Http:// www.cer-mark.com Postcode: 518103 E-mail: service@cer-mark.com



This certificate is responsible for testing sample only.
Please refer to this corresponding test report to get testing process and data.

CERTIFICATE

ATTESTATION Certificate of Compliance

Technical file of the company mentioned below has been inspected and audit has been completed successfully

The Low Voltage Directive 2014/35/EU has been taken as references for these processes.

Certificate's Holder : QingDao ChengKong Electrical-Auto Co., Ltd.
Address : Room 5-402, No.147 Xining Road, Zhuhai Community, Huangdao District, Qingdao, Shandong, China
Manufacturer : QingDao ChengKong Electrical-Auto Co., Ltd.
Address : Room 5-402, No.147 Xining Road, Zhuhai Community, Huangdao District, Qingdao, Shandong, China
Product Name : Furniture Power Distribution Unit
Product Model (S) : JN02-00-22, JN02-00-22Y, JN02-00-02, JN02-00-21, JN02-00-23, JN02-00-03, JN02-00-04
Trade Mark : Roozmausy
Related Directive : 2014/35/EU
Related Standards : EN IEC 62368-1:2020 + A11:2020
Certificate Number : HK2405271322S
Report No. : HK2405271322-SR
Registration Date : Jun. 04, 2024



Certification Manager



The information of the certificate can be checked through www.cer-mark.com. The CE mark which is shown on the certificate can only be used under the conditions that the products complete with all of the relevant Directives of CE Declaration of Conformity. The Manufacturer should be responsible for the internal production control so that the products complied with the essential requirements of the above mentioned Directive(s). Certificate holder must notify all changes to the original certification laboratory of HUAKE.



Shenzhen HUAKE Testing Technology Co., Ltd.

Add.: 1-2/F., Building B2, Junfeng Zhongcheng Zhizao Innovation Park, Heping, Fuhai Street, Bao'an District, Shenzhen, Guangdong, China
Tel.: +86-755-2302 9901 Http:// www.cer-mark.com Postcode: 518103 E-mail: service@cer-mark.com



This certificate is responsible for testing sample only.
Please refer to this corresponding test report to get testing process and data.

CERTIFICATE

ATTESTATION Certificate of Compliance

Technical file of the company mentioned below has been inspected and audit has been completed successfully

The EMC Directive 2014/30/EU has been taken as references for these processes.

Certificate's Holder : QingDao ChengKong Electrical-Auto Co., Ltd.
Address : Room 5-402, No.147 Xining Road, Zhuhai Community, Huangdao District, Qingdao, Shandong, China
Manufacturer : QingDao ChengKong Electrical-Auto Co., Ltd.
Address : Room 5-402, No.147 Xining Road, Zhuhai Community, Huangdao District, Qingdao, Shandong, China
Product Name : Furniture Power Distribution Unit
Product Model (S) : JN02-00-22, JN02-00-22Y, JN02-00-02, JN02-00-21, JN02-00-23, JN02-00-03, JN02-00-04
Trade Mark : Roozmausy
Related Directive : 2014/30/EU
Related Standards : EN 55032:2015 + A1:2020 + A11:2020
EN IEC 61000-3-2:2019 + A1:2021
EN 61000-3-3:2013 + A1:2019 + A2:2021
EN 55035:2017 + A11:2020
Certificate Number : HK2405272729E
Report No. : HK2405272729-1ER
Registration Date : Jun. 04, 2024



The information of the certificate can be checked through www.cer-mark.com. The CE mark which is shown on the certificate can only be used under the conditions that the products complete with all of the relevant Directives of CE Declaration of Conformity. The Manufacturer should be responsible for the internal production control so that the products complied with the essential requirements of the above mentioned Directive(s). Certificate holder must notify all changes to the original certification laboratory of HUAKE.



Shenzhen HUAKE Testing Technology Co., Ltd.

Add.: 1-2/F., Building B2, Junfeng Zhongcheng Zhizao Innovation Park, Heping, Fuhai Street, Bao'an District, Shenzhen, Guangdong, China
Tel.: +86-755-2302 9901 Http:// www.cer-mark.com Postcode: 518103 E-mail: service@cer-mark.com

Certificate of Compliance

EU- Restriction of the use of certain hazardous substances (RoHS) -

Report No. : LBTR230314130R

Applicant : QingDao ChengKong Electrical-Auto Co.,Ltd
Address : Zhuhai Community, Huangdao District, Qingdao ,
Shandong,China

Manufacturer : QingDao ChengKong Electrical-Auto Co.,Ltd
Address : Zhuhai Community, Huangdao District, Qingdao ,
Shandong,China

Product : Power Adapter

Model No. : JN02-00-22 JN02-00-22Y JN02-00-02 JN02-00-21 JN02-00-23

Trade Mark : N/A

Test Standards	IEC 62321-3-1:2013
	IEC 62321-5:2013
	IEC 62321-4:2013+AMD1:2017
	IEC 62321-7-1:2015
	IEC 62321-7-2:2017
	IEC 62321-6:2015

The test results based on the above specified products comply with the EU RoHS 2 Directive 2011/65 / EU Appendix II Amendment Directive (EU) 2015/863 as last amended by Directive (EU) 2017/2102 limit requirements.

The test results apply only to the particular sample tested and to the specific tests carried out. Specifically to the sample investigated in our test reference number only.

Other relevant Directives have to be observed.



Chief Manager
Labtest
AUTHORIZED

Date of Issue: Mar. 14, 2023

This statement is based on a single evaluation of the sample(s) of above mentioned product. It does not imply an assessment of the whole production.

SHENZHEN LABTEST TECHNOLOGY LABORATORY LTD.

901-12, Block 1, No.9 Jinxu Middle Road, Laokong Community, Longtian

Street, Pingshan District, Shenzhen, Guangdong, China. www.labtest.com