

Original Instructions

This is a recliner with an electric backrest and footrest controlled via buttons. This product shall only be used together with the included power supply unit.

It is the responsibility of every person who installs, uses, repairs or services this electric recliner to carefully read these instructions.

Installation Instructions

Step 1:

Attach the Backrest to the Seat Base

Slide the Backrest Female Brackets to the Seat Base Male Brackets. Push until you hear a click on both sides. This means that the two brackets on the backrest are securely attached.

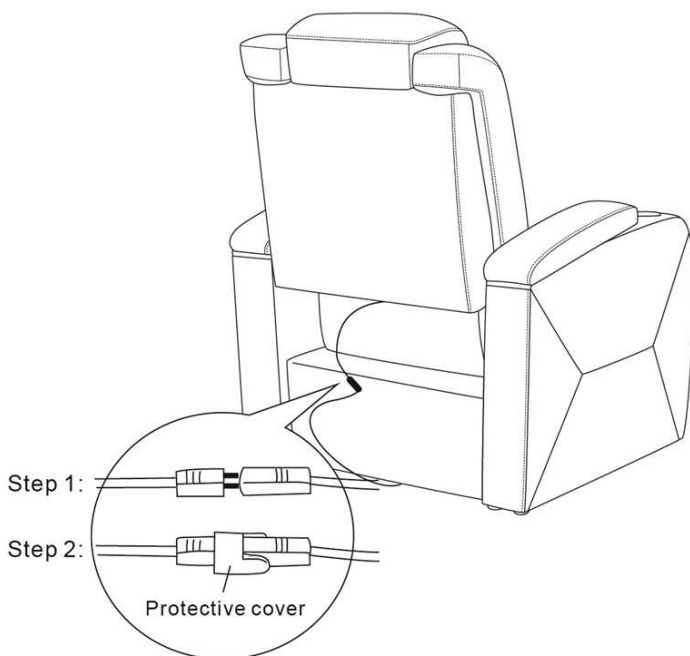
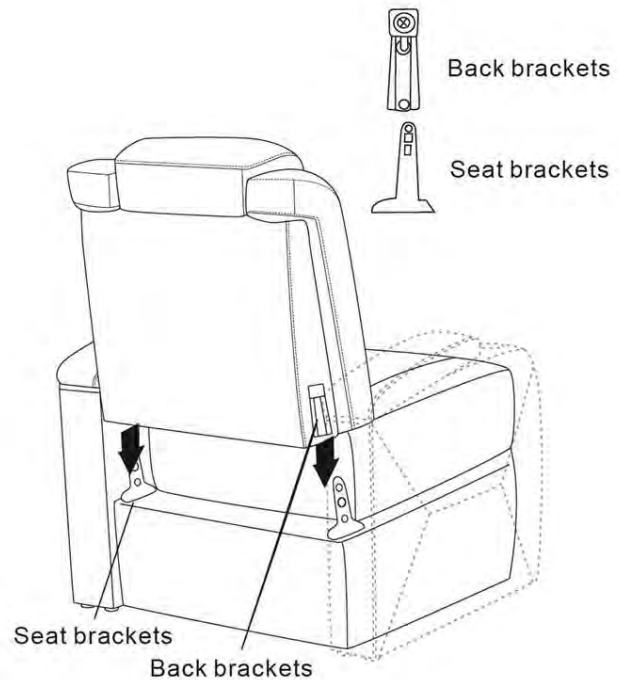

Step 2:

Connect the Power Headrest Cables

Connect each Powered Headrest Female Cable to each Powered Headrest Male Cable.

Step 3:
Connect the Power Cables

End Seats: Plug in the Power Adapter Cable to the Power Adapter. Connect the Power Adapter to the seat base.

Middle Seat: Plug in the Headrest Light Power Cable to seat base. Plug in all four cables to a power source.

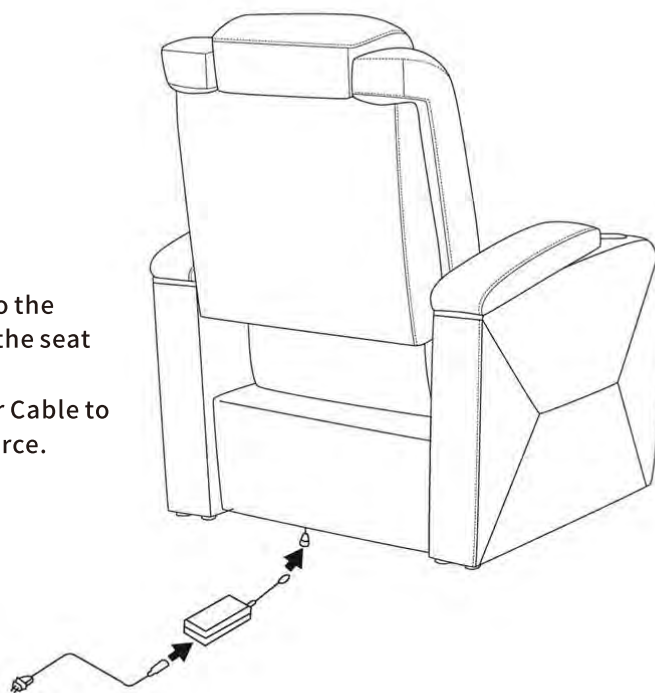

Step 4:
Attach the Tray Tables

Open the in-arm storages to find your Tray Tables. Place each Tray Table into an accessory mount.

Using the Power Control Panel

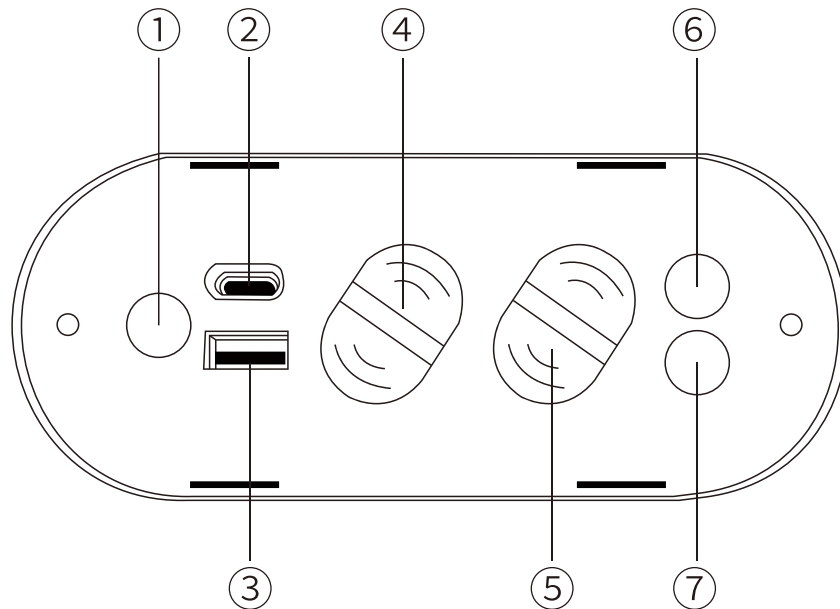

① LED button

This button controls the surrounding base lighting and the illuminated cup holder on each armrest.

② TYPE-C charging port

A Type-C port is included in this power recliner switch.

③ USB-A charging port

A USB-A port is included in this power recliner switch.

④ Power recline

Long press this button and you can adjust your seat to any desired position.

⑤ Power headrest

A long press on the power headrest button makes it easy to adjust to many different positions, reducing neck and shoulder strain.

⑥ Home button

Returns chair to default position.

⑦ Memory button

The best seat position is selected using the manual adjustment buttons and then stored in the memory by pushing the memory button.

Important Safety Instructions



DANGER

TO REDUCE THE RISK OF ELECTRIC SHOCK OR SERIOUS INJURY:

- Disconnect the electrical plug from the wall outlet before cleaning, moving, servicing or when not in use for an extended period of time.
- Do not use this product if it is wet, in water, around water or any liquid.



WARNING

TO REDUCE THE RISK OF BURNS, FIRE, ELECTRIC SHOCK OR SERIOUS INJURY.

- Do not operate the unit until the back is installed and locked.
- Closely supervise children and disabled persons using this product.
- This product has many moving parts, serious injury can occur if not used properly. Keep children and pets away from the mechanism. Keep hands, fingers and body parts away from the mechanism.
- Sit down in the unit slowly. To avoid tip over, do not throw your weight against the back of the unit. Move the unit into or out of the reclining position slowly, making sure that no children or pets are in close proximity.
- Only the occupant should operate the unit. Never attempt to open the leg rest by pulling on it.
- Do not stand, sit or place extra weight on the arms, back or open leg rest.
- To safely exit the unit and prevent a tripping hazard bring the back upright and close the leg rest.
- Provide a clear path for operation of the chair, back and leg rest. Place tables and area rugs at a distance to allow the leg rest to fully extend without rubbing or interference.
- Keep hands, arms and body parts away from the open area between a reclined back and an upright back on a motion sofa. This area must remain clear at all times to provide unobstructed movement and prevent injury that could occur when a reclined back is returning toward the upright position.
- Use care when moving the product. Before lifting the product, secure the mechanism to prevent unexpected opening or movement. Never move the product by the mechanism, leg rest, handle, reclining back or swivel base. Disconnect modular units. Securely grip non-moving parts.
- Do not use this product if it is damaged. Do not use attachments or substitute parts.
- Check the condition of the power transformer, electrical cord, plug, and connectors regularly. Keep the power transformer and electrical cords away from heat sources. Never operate the unit with a damaged power transformer, electrical cord, plug or connector.
- Do not use unit if power control is damaged or wet. Do not use unit if the hand wand has been dropped in water or any liquid.
- This product is not intended for use as a health-care device.
- Users of medical devices should contact their healthcare provider before using this product. Do not use this product if you have poor circulation, are immobile or cannot sense heat, except as directed by your healthcare provider.
- This product is intended for indoor residential use only.
- Always keep open flame and lit cigarettes away from upholstered furniture. Upholstered furniture may burn rapidly with toxic gas and thick smoke.

Proposition 65 Information

Q. what is Proposition 65?

A. You might have seen Proposition 65 warning labels at hotels, banks, restaurants, and even at theme parks. Proposition 65 is a California law that requires warning labels on products that may contain one of more than 800-plus chemicals or ingredients that the California Office of Environmental Health Hazard Assessment (OEHHA) has deemed to cause cancer or other reproductive toxicity. Chemicals and elements on this list include saw dust, brass, and other everyday substances, which can be found in very common household items, such as lamps, tableware, jewelry, crystal glasses, electric cords, beauty products, automobiles, and furniture.

Q. why did I find a Proposition 65 warning on my furniture product?

A. This warning label is very common and can be found on almost every piece of furniture sold in the state of California. By law the state of California requires that we include a Proposition 65 warning on all of our products.

Warranty Information

We are proud of its high standards of quality and workmanship that go into our products. The customer is protected by the following Limited Warranty, which applies to seats under normal indoor residential use. This warranty does not apply to seats used for commercial, institutional, or other non-residential uses.

30 days LIMITED WARRANTY: We typically provides 30 days comprehensive coverage for all components such as materials, foam and frame parts, and mechanisms including motorized parts from defective materials or workmanship.

MATERIAL: Normal fabric fading, shrinking, or stretching is not covered by this warranty. Similarly, the natural markings, stretching, and shrinking of leather is a proud mark of authenticity and therefore not covered by this warranty. Evidence of improper cleaning, abuse, or abnormal use of the materials will void this warranty.

FOAM AND FRAME PARTS: We warrant these components for 30 days from the time of delivery, against manufacturing defects. Foam compression is natural, and therefore not covered by this warranty.

MECHANISMS: We warrant these components for 30 days from the time of delivery, against manufacturing defects. After the warranty period, the customer is responsible for inspection, labor and transportation costs.

No warranties, express or implied, apply after the expiration of this Limited Warranty. The warranty period covers repair, substitution, and replacement. No returns or refunds are covered. A proof of purchase is required to service a claim; simply present the bill of sale to the dealer from whom the item was purchased, to request warranty service. We are not liable for incidental or consequential damages occurring outside the terms of this warranty, even if advance knowledge of such damages was possible.