











Assembly Instructions

Caution : You must read this before you proceed

Care & Maintenance

- ⊘  ● Not for commercial use. For residential use only.
 - ✓  ● Furniture may scratch floors. We recommend using furniture pads to protect your floors.
 - ⊘  ● Do not put hot items directly on furniture surface.
 - ⊘  ● Do not clean furniture with harsh cleansers or polish.
 - ⊘  ● Do not place furniture under direct sunlight.
 - ⊘  ● Do not place furniture near heating or cooling vents.
 - ⊘  ● Do not write on furniture without a padded barrier to protect the surface.
 - ⊘  ● Do not place furniture outside . For indoor use only.
 - ⊘  ● Stains may be removed with mild soap solution and damp cloth.
 - ⊘  ● Children should not climb or jump on the furniture.
-
- ✓  ● Dust and pick-up spills using a clean, non-colored, lint-free cloth.

Please look in carton for hardware packs and legs.
Sets often ship in multiple boxes and may arrive a day or two apart.

TABLE



Parts List

Label	Picture	Description	QTY
①		TOP	1
②		Frame	1
③		Frame	1
④		Frame	4
⑤		Frame	4
⑥		Part	1

Hardware

Label	Picture	Description	QTY
Ⓐ		Bolt	24
Ⓑ		Bolt	4
Ⓒ		Washer	4
Ⓓ		Allen Wrench	1
Ⓔ		Feet	6

Assembly Preparation

Before Beginning Assembly :

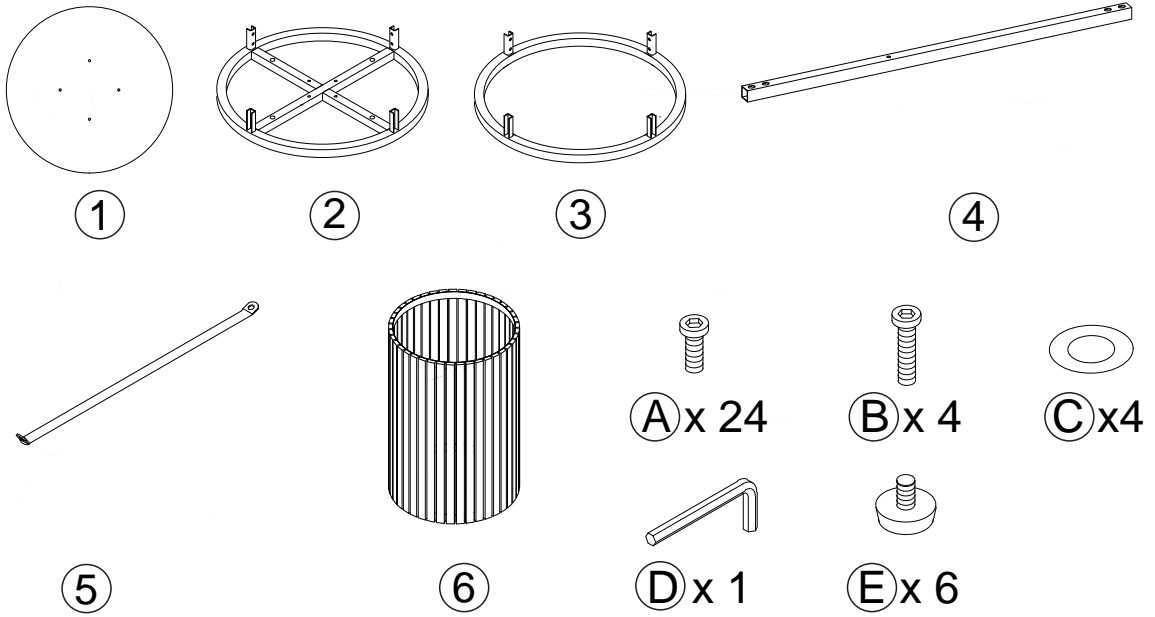

- Read instructions, cover to cover-



- Have 2 adults on hand for assembly-



- Do not assemble on flooring or carpet-



- Assemble on a clean non-marring surface (packing foam)-



- Save all packaging until finished-

Assembly Steps

Overview

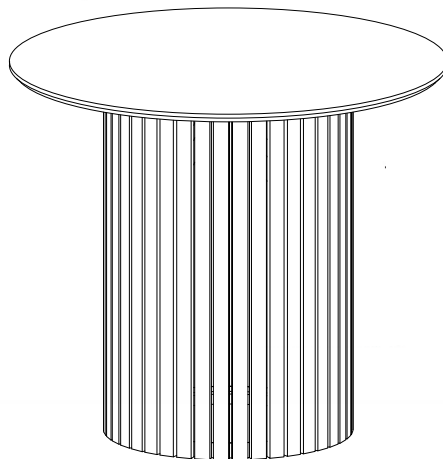

This table has multiple parts and may require up to 30 minutes to assemble. The picture above provides an overview of the table parts to help you visualize and understand each component. Please read through the instructions below to familiarize yourself with the parts and steps before assembly.

Step1

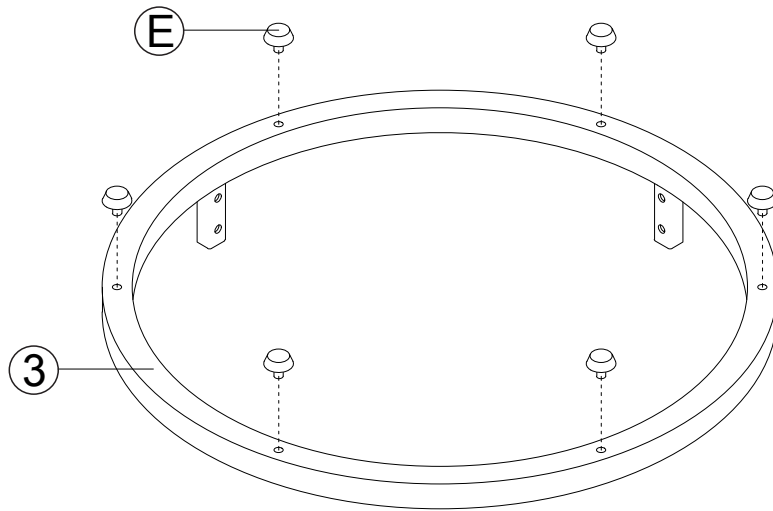
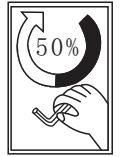

Attach part E to frame ③

Step2

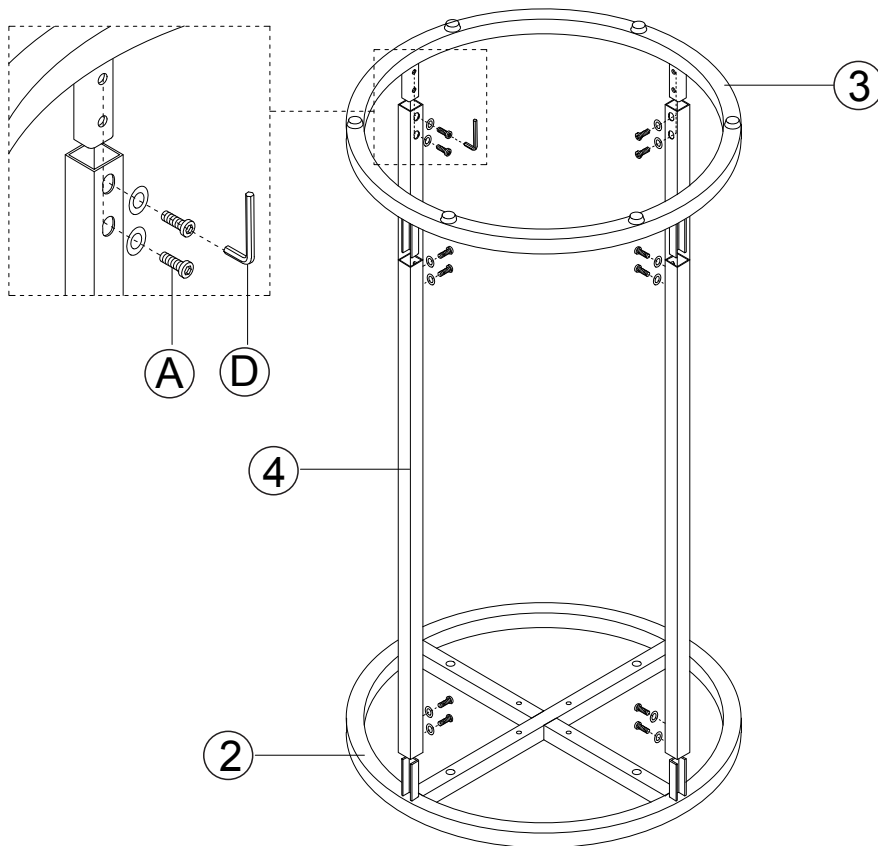
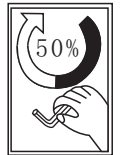

Assemble frames ②, ③, and ④ using Allen Wrench ① and Bolt ②.

Step3

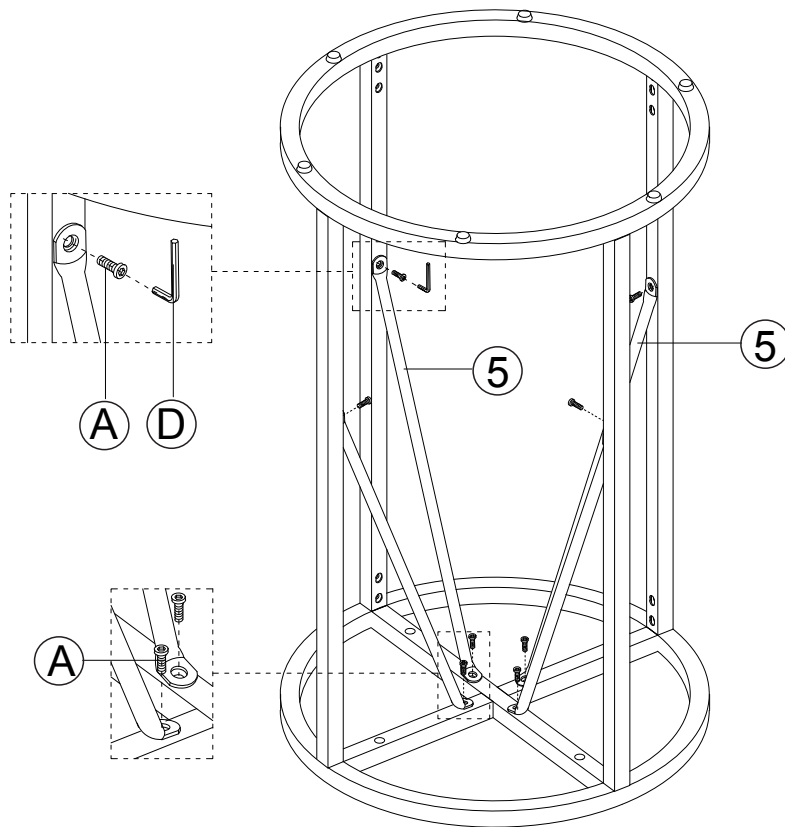
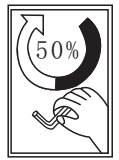

Assemble frame ⑤ using Allen Wrench ④ and Bolt ③.

Step4

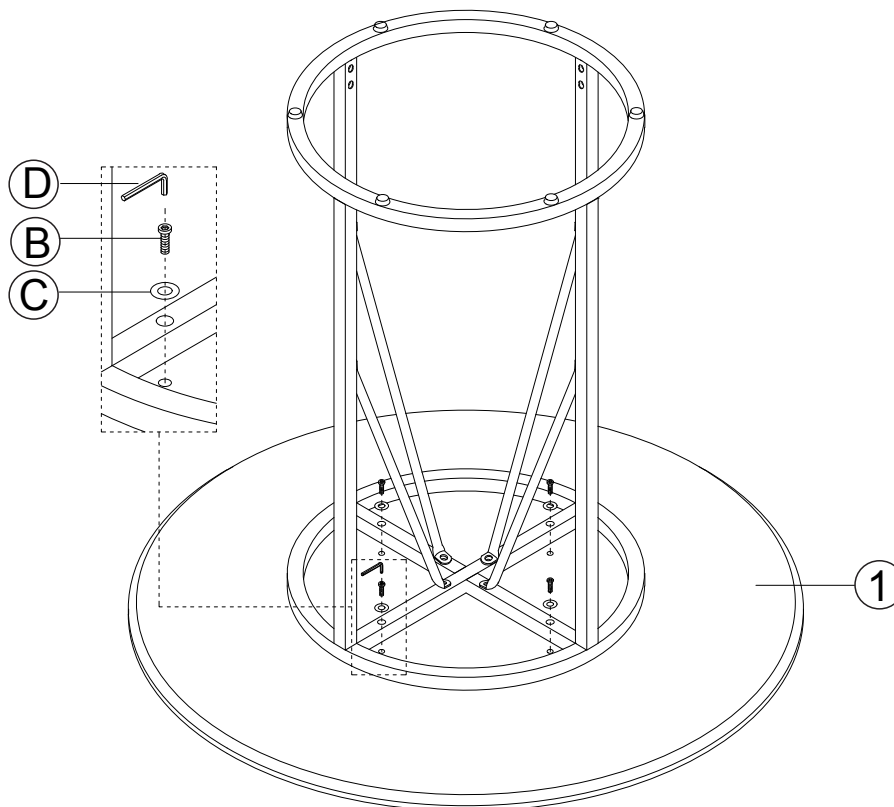

Attach the frame to the top ① using Allen Wrench ④ Bolt ③ and Washer ②.

Step5

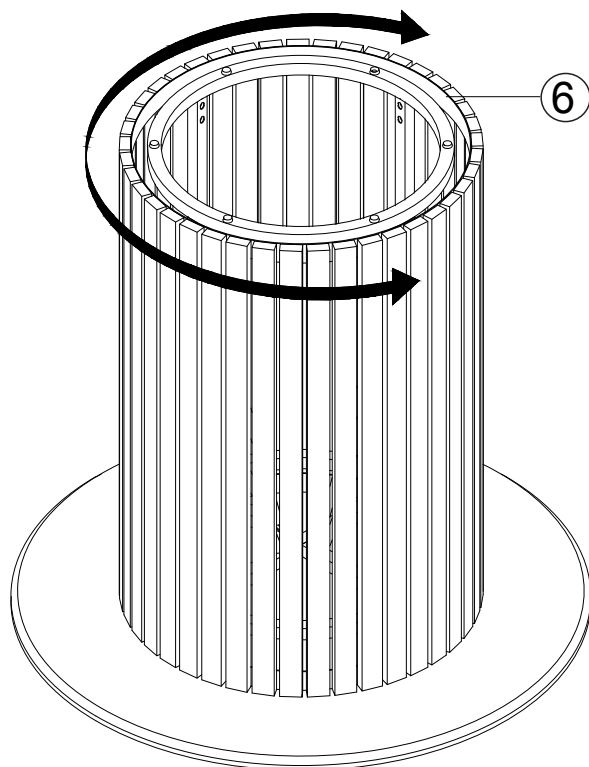

Attach the part ⑥ to the table

Step6

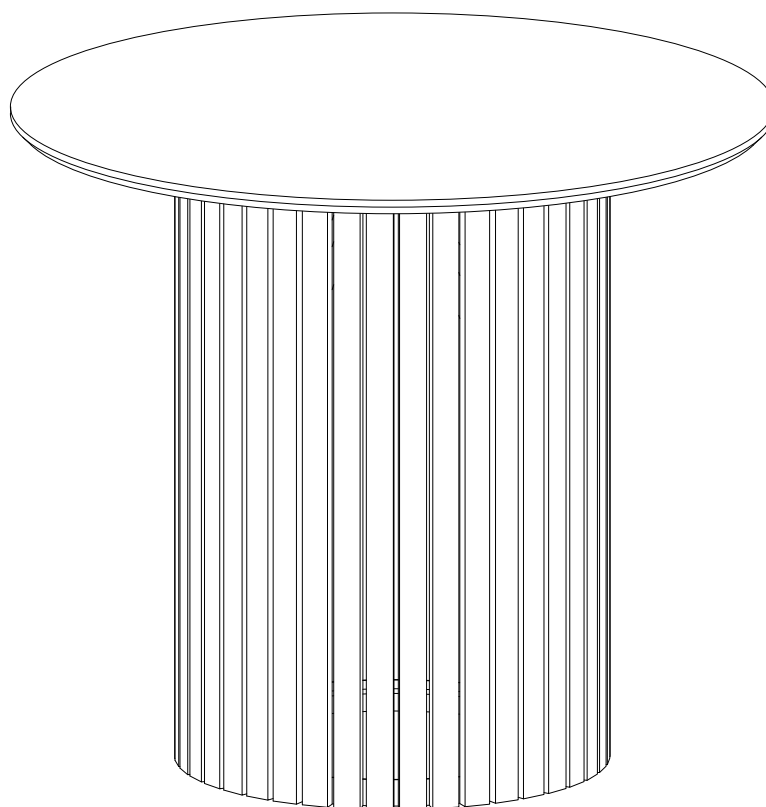

With the help of your adult partner, stand the table up.
The table is now ready for use.