

*ASSEMBLY INSTRUCTIONS  
COASTER FINE FURNITURE*



*COFFEE TABLE*

# ASSEMBLY INSTRUCTIONS

## ASSEMBLY TIPS:

1. Remove hardware from box and sort by size.
2. Please check to see that all hardware and parts are present prior to start of assembly.
3. Please follow attached instructions in the same sequence as numbered to assure fast & easy assembly.



## WARNING!

1. Don't attempt to repair or modify parts that are broken or defective. Please contact the store immediately.
2. This product is for home use only and not intended for commercial establishments.

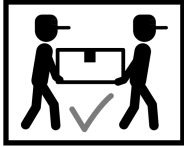

ASSEMBLY TIME 35 MINUTES

## PARTS IDENTIFICATION

A

TOP

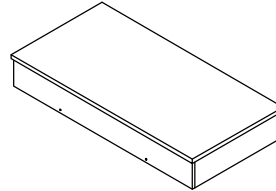

1PC

B

SHELF

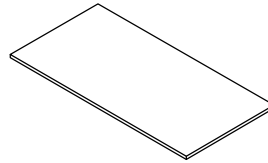

1PC

C

TOP CROSSBAR

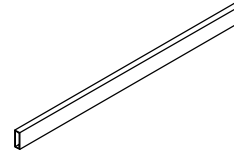

2PCS

D

BOTTOM CROSSBAR

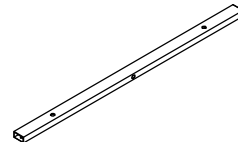

2PCS

E

LEG 1

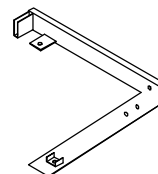

2PCS

# ASSEMBLY INSTRUCTIONS

## PARTS IDENTIFICATION

F LEG 2 2PCS

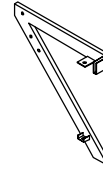

G BOTTOM SUPPORT CROSSBAR 1PC

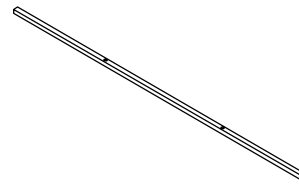



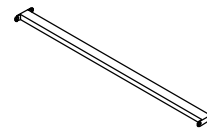

H TOP SUPPORT CROSSBAR 2PCS



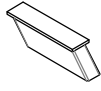

# ASSEMBLY INSTRUCTIONS

Z

## HARDWARE IDENTIFICATION

1	SHORT BOLT (1/4" x 12mm SR)		24PCS
2	MEDIUM BOLT (1/4" x 22mm SR)		8PCS
3	CAP		4PCS
4	LONG BOLT (1/4" x 47mm SR)		2PCS

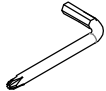
5	SCREW (4 x 25mm SR)		2PCS
6	WASHER		4PCS
7	ALLEN WRENCH (4mm)		1PC

### STEP 1

Do not tighten until each step is completed or instructed.

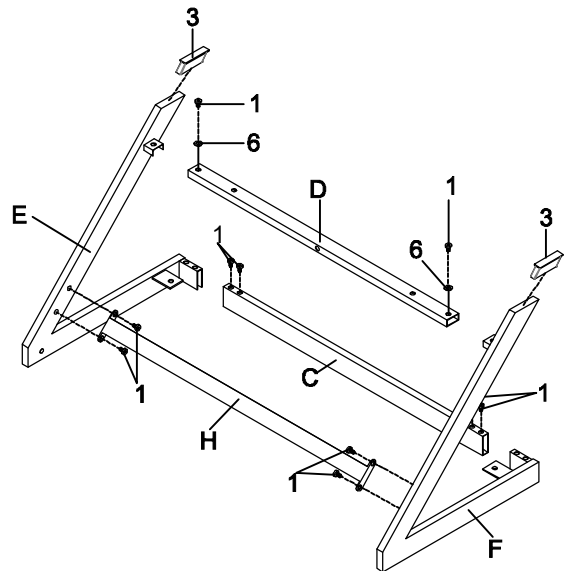
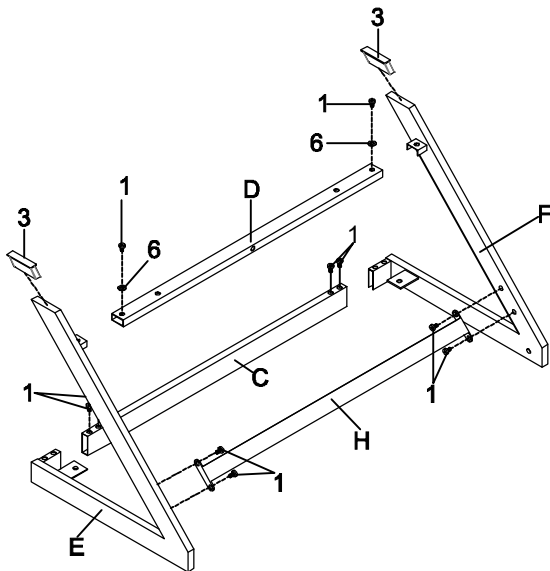

# ASSEMBLY INSTRUCTIONS

## STEP 2

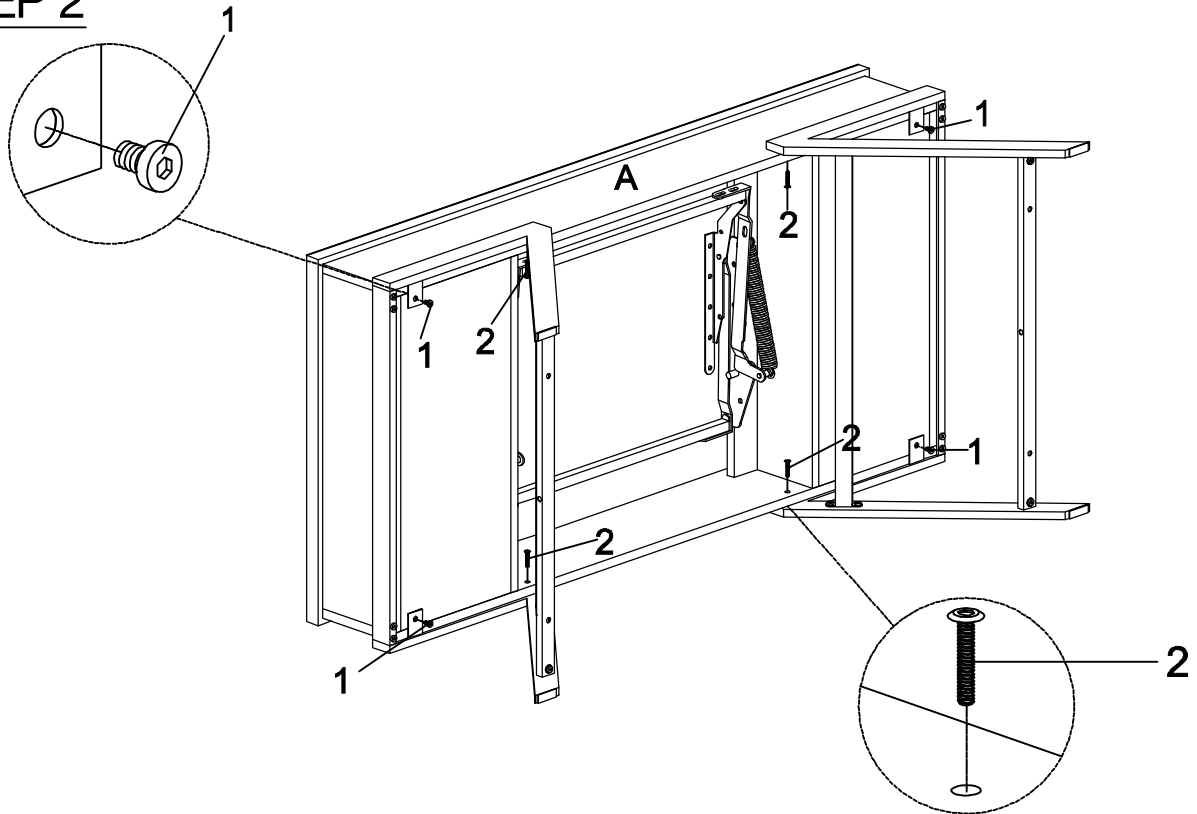

## STEP 3

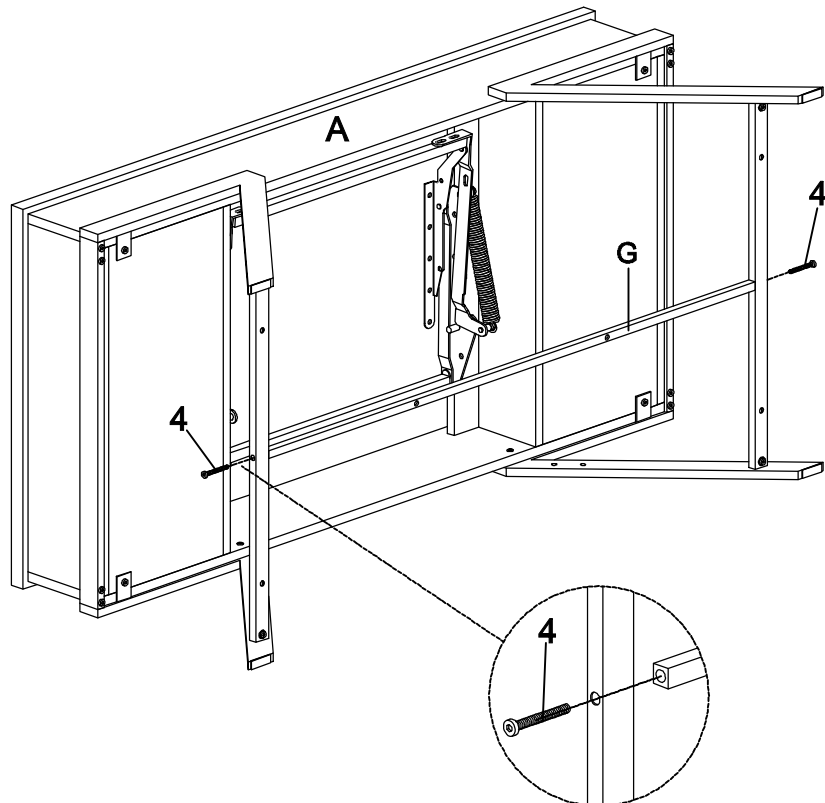

# ASSEMBLY INSTRUCTIONS

## STEP 4

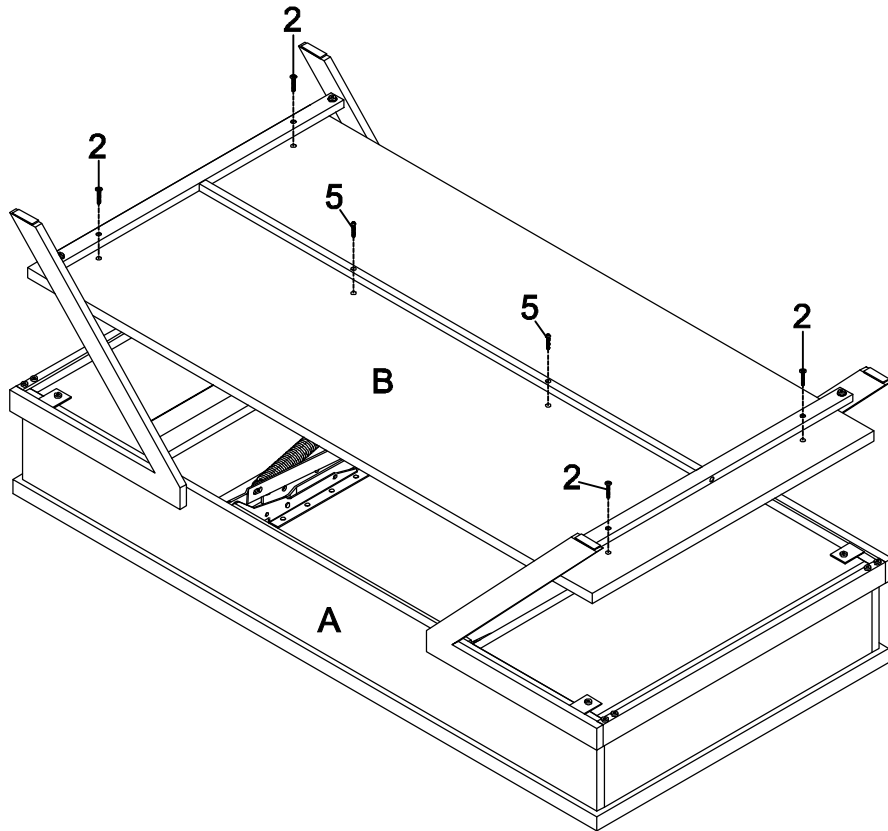

## STEP 5

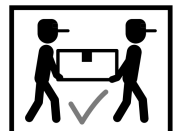
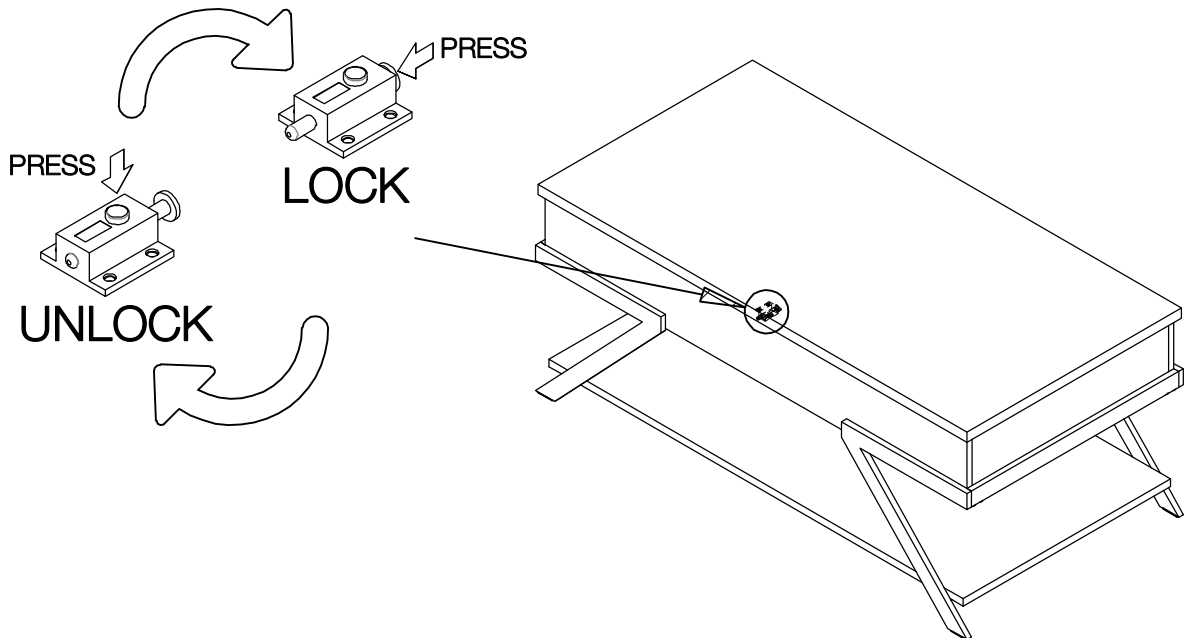

# ASSEMBLY INSTRUCTIONS

**Product Size : 1207 X 597 X 495~737 H (MM)**

**Product Size : 47.5" X 23.5" X 19.5"~29"**

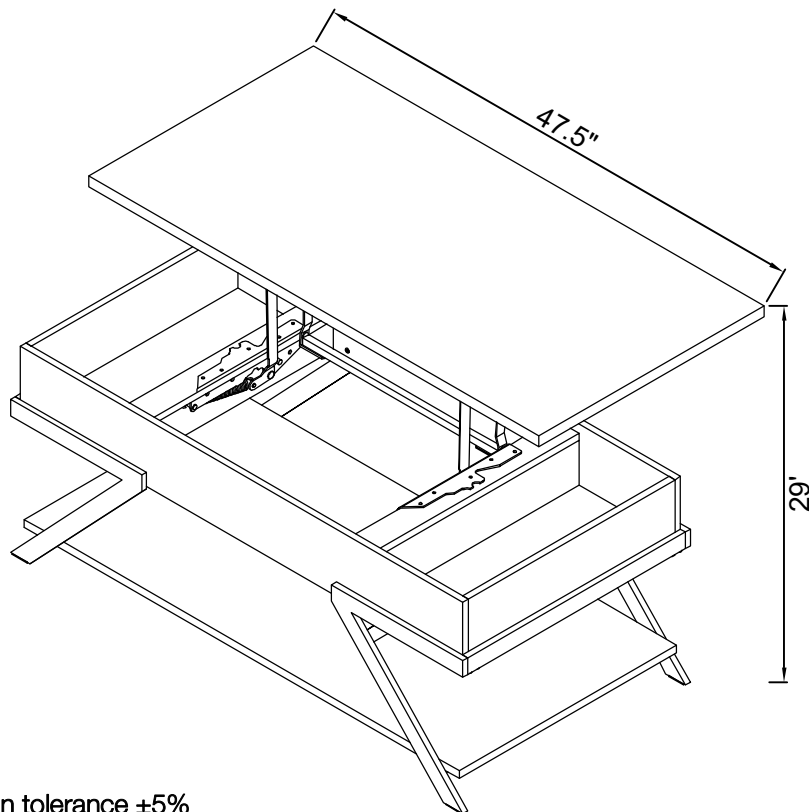
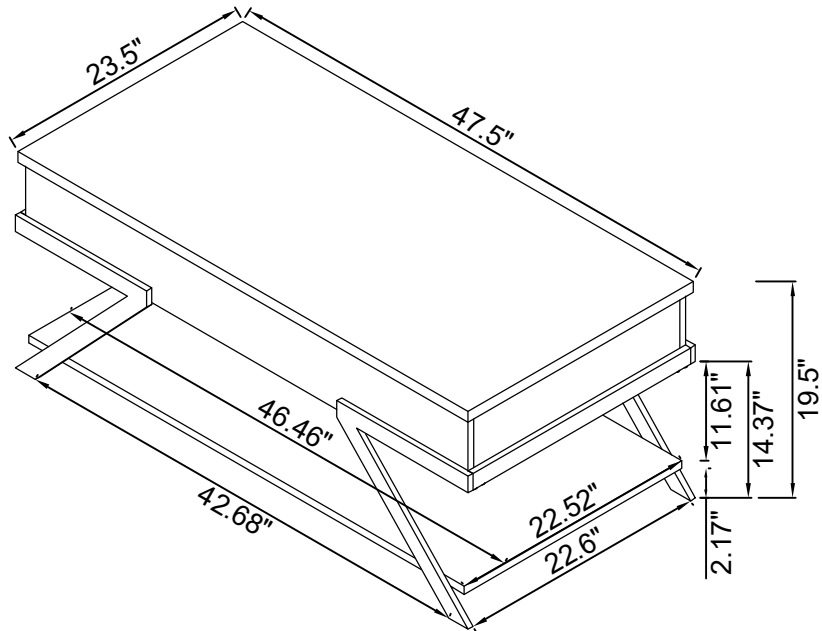

Note : Dimension tolerance  $\pm 5\%$