

USA office: Fontana **AUS** office: Truganina **FRA** office: Saint Vigor d'Ymonville
GBR office: FDS Corporation Limited, Unit 4, Blackacre Road, Great Blakenham,
Ipswich, IP6 0FL, United Kingdom

If you're having difficulty, our friendly
customer team is always here to help.

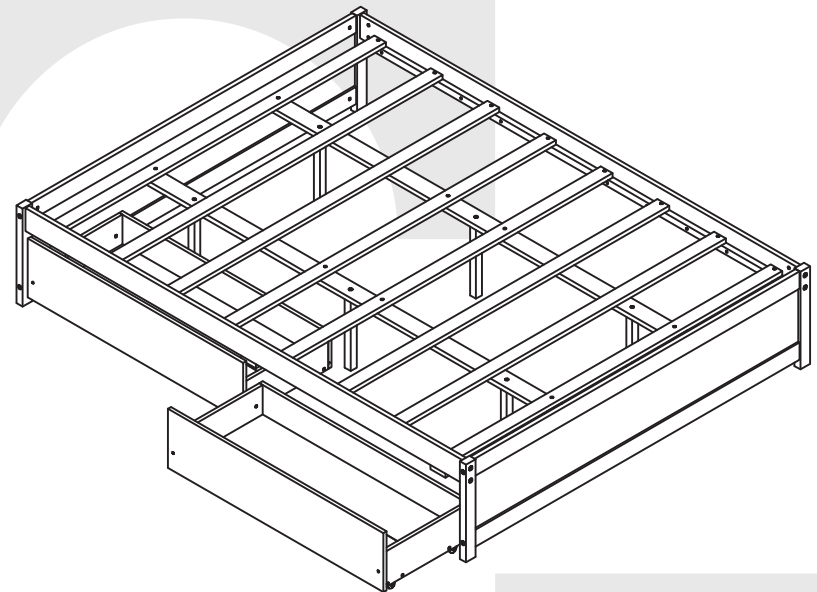

USA:cs.us@costway.com
AUS:cs.au@costway.com
GBR:cs.uk@costway.com
FRA:cs.fr@costway.com



Bed Frame
Cadre de Lit
HU11165-Q

THIS INSTRUCTION BOOKLET CONTAINS **IMPORTANT** SAFETY INFORMATION.
PLEASE READ AND KEEP FOR FUTURE REFERENCE.

EN



Before You Start

- ⚠ Please read all instructions carefully.
- ⚠ Retain instructions for future reference.
- ⚠ Separate and count all parts and hardware.
- ⚠ Read through each step carefully and follow the proper order.
- ⚠ We recommend that, where possible, all items are assembled near to the area in which they will be placed in use, to avoid moving the product unnecessarily once assembled.
- ⚠ Always place the product on a flat, steady and stable surface.
- ⚠ Keep all small parts and packaging materials for this product away from babies and children as they potentially pose a serious choking hazard.

FR



Avant de Commencer

- ⚠ Veuillez lire attentivement toutes les instructions.
- ⚠ Conservez les instructions pour vous y référer ultérieurement.
- ⚠ Vérifiez toutes les pièces et les accessoires.
- ⚠ Lisez attentivement chaque étape et suivez l'ordre correct.
- ⚠ Nous recommandons que, dans la mesure du possible, tous les produits soient assemblés à proximité de la zone où ils seront utilisés, afin d'éviter tout déplacement inutile du produit une fois assemblé.
- ⚠ Placez toujours le produit sur une surface plane et stable.
- ⚠ Conservez toutes les petites pièces de ce produit et les matériaux d'emballage hors de portée des bébés et des enfants, car ils pourraient présenter un risque d'étouffement.

EN



Return / Damage Claim Instructions

- ⚠ **DO NOT discard the box / original packaging.**
In case a return is required, the item must be returned in original box. Without this your return will not be accepted.
- ⚠ **Take a photo of the box markings.**
A photo of the markings (text) on the side of the box is required in case a part is needed for replacement. This helps our staff identify your product number to ensure you receive the correct parts.
- ⚠ **Take a photo of the damaged part (if applicable).**
A photo of the damage is always required to file a claim and get your replacement or refund processed quickly. Please make sure you have the box even if it is damaged.
- ⚠ **Send us an email with the images requested.**
Email us directly from marketplace where your item was purchased with the attached images and a description of your claim.

FR



Instructions De Retour / Réclamation De Dommages

- ⚠ **NE PAS jeter la boîte/l'emballage d'origine.**
Dans le cas où un retour est requis, l'article doit être retourné dans sa boîte d'origine. Sans cela, votre retour ne sera pas accepté.
- ⚠ **Prenez une photo des marquages de la boîte.**
Une photo des marquages (texte) sur le côté de la boîte est requise au cas où une pièce serait nécessaire pour le remplacement. Cela aide notre personnel à identifier votre numéro de produit pour s'assurer que vous recevez les bonnes pièces.
- ⚠ **Prenez une photo des dommages (le cas échéant).**
Une photo des dommages est toujours requise pour déposer une réclamation et obtenir rapidement votre remplacement ou votre remboursement. Assurez-vous d'avoir la boîte même si elle est endommagée.
- ⚠ **Envoyez-nous un e-mail avec les images demandées.**
Envoyez-nous un e-mail directement depuis le marché où votre article a été acheté avec les images ci-jointes et une description de votre réclamation.

Detail View / Vue Détaillée

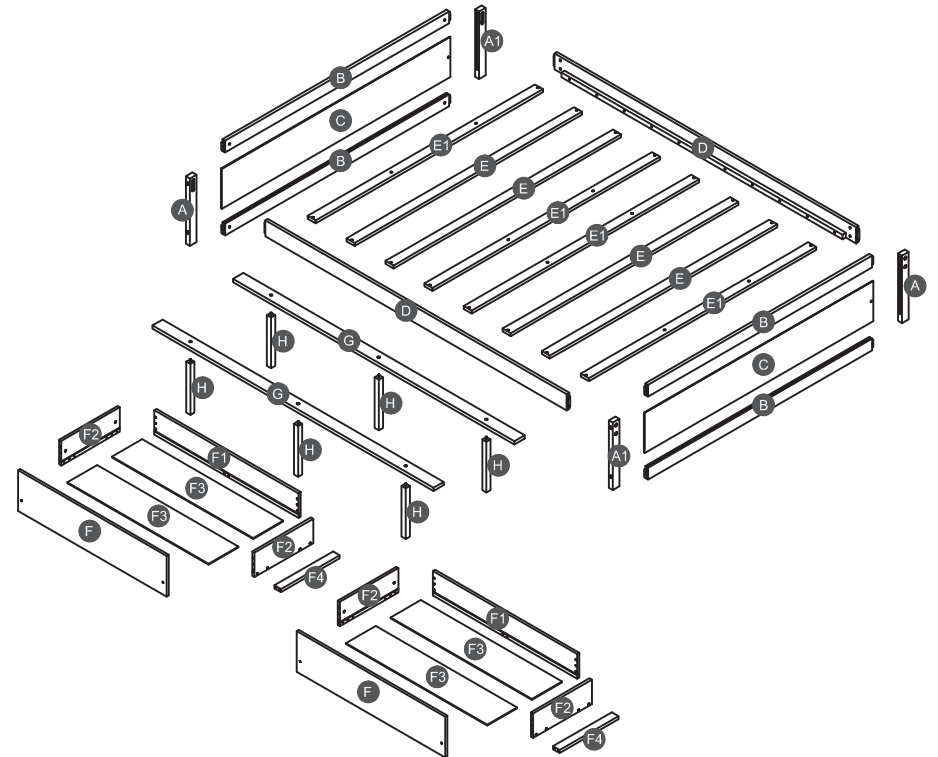
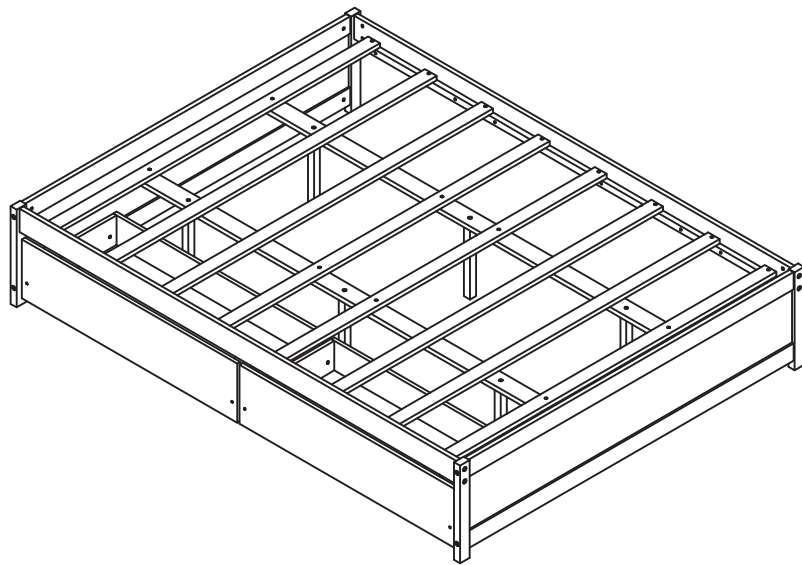

Part List / Liste des Pièces

A x 2



Legs (left front/right back)
/Pieds (gauche avant/droit arrière)

A1 x 2



Legs (left back/right front)
/Pieds (gauche arrière/droit avant)

B x 4



Horizontal bars HB/FB
/Barres horizontales HB/FB

C x 2

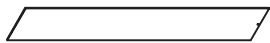

Side panels HB/FB
/Panneaux latéraux HB/FB

D x 2



Side rails
/Rails latéraux

E x 4



Slats
/Lattes

E1 x 4



Slats
/Lattes

F x 2



Front drawer panels
/Panneaux avant des tiroirs

F1 x 2



Back panels of the drawer
/Panneaux arrière du tiroir

F2 x 4

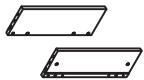

Drawers (left/right)
/Tiroirs (gauche/droite)

F3 x 4



Drawer bottom plates
/Panneaux inférieur des tiroirs

F4 x 2



Drawer supporters
/Supports de tiroir

G x 2



Lower support slats
/Lattes de support inférieures

H x 6

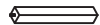

Leg supporters
/Supports de pieds

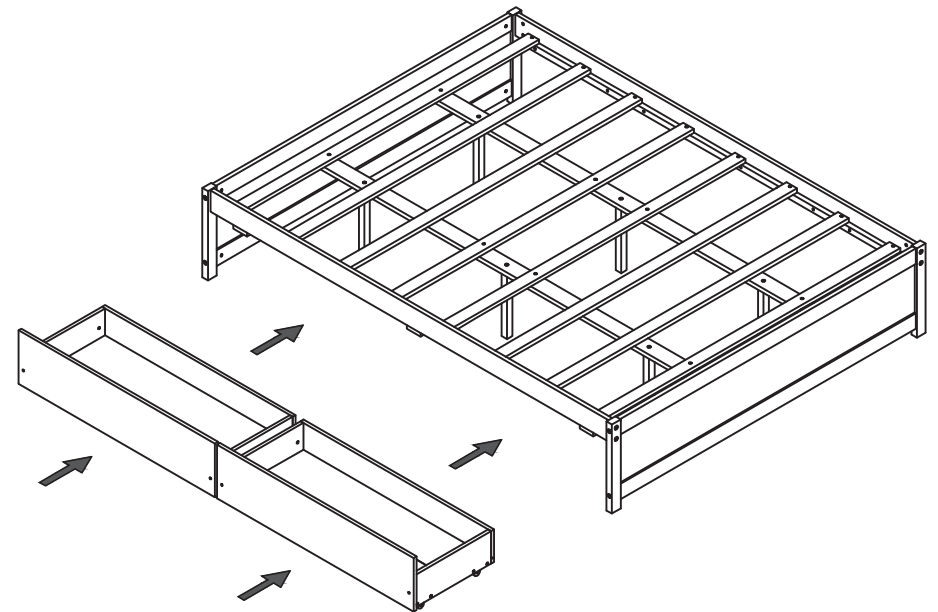

10



EN: Push the drawers under the bed

FR: Poussez les tiroirs sous le lit.

9

2		7		9	
	x8		x8		x16

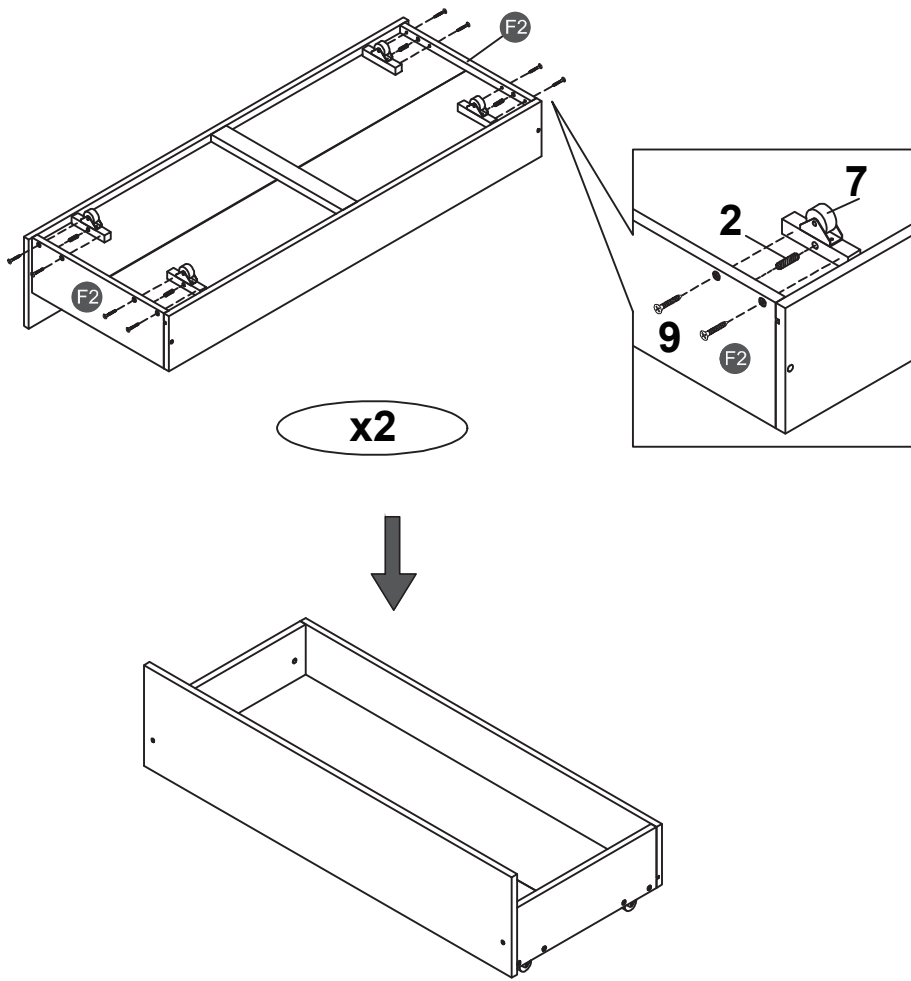

Hardware List / Liste des Accessoires

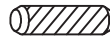
	Ø8*30mm
1	X24

Wooden dowels
/Chevilles en bois

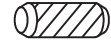
	Ø10*20mm
2	X8

Wooden dowels
/Chevilles en bois

	(Ø15)1/4"*80mm
3	X16

Hex-head bolts
/Boulons à tête hexagonale

	(Ø12)1/4"*60mm
4	X8

Hex-head bolts
/Boulons à tête hexagonale

	(1/4")4.5*58mm
5	X1

Allen key
/Clé Allen

	1/4"*15(9.5mm)
6	X24

Horizontal-hole bolts
/Boulons à trous horizontaux

	100*52*20mm
7	X8

Wheels
/Roues

	80*40*19mm
8	X3

Drawer stoppers
/Butoirs de tiroir

	Ø4*30mm
9	X46

Screws
/Vis

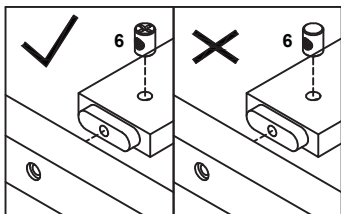
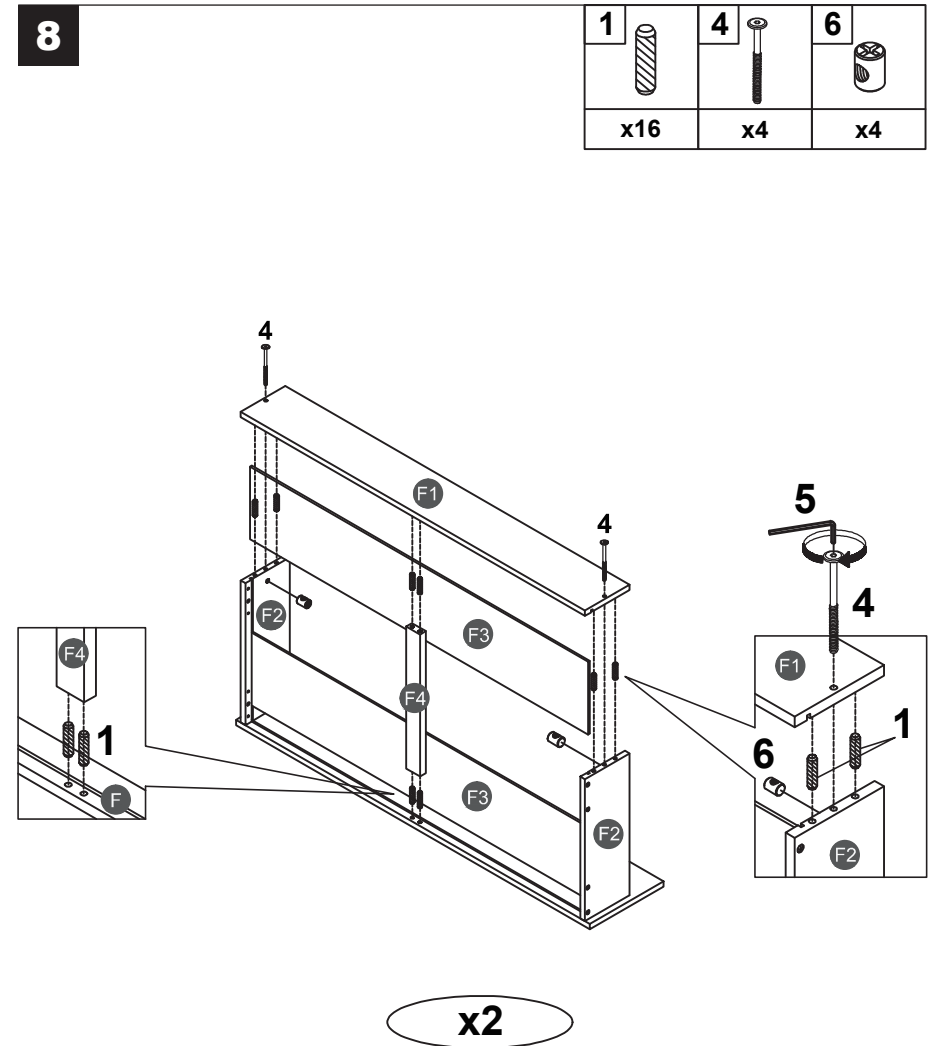
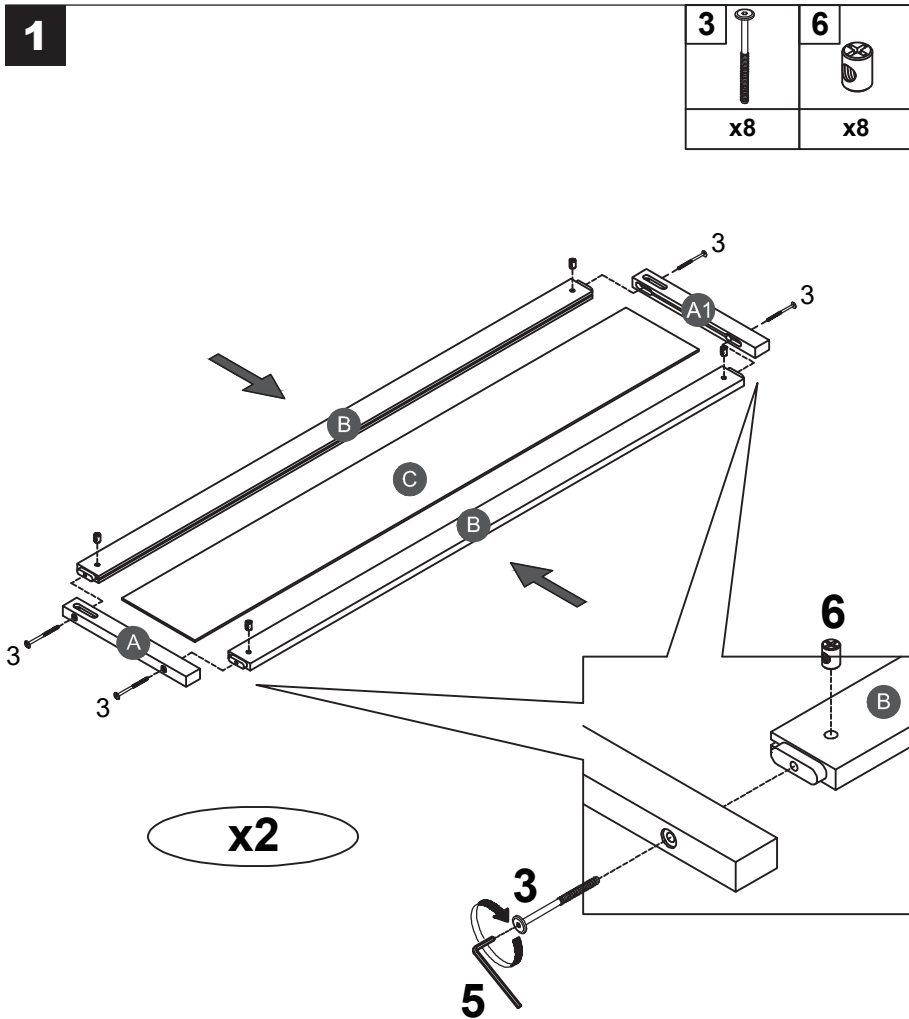

EN:Note: The side of part #6 with the "x" mark needs to be facing up, otherwise it cannot be tightened.

FR:Remarque: le côté de la pièce #6 avec la marque « x » doit être orienté vers le haut, sinon il ne peut pas être serré.

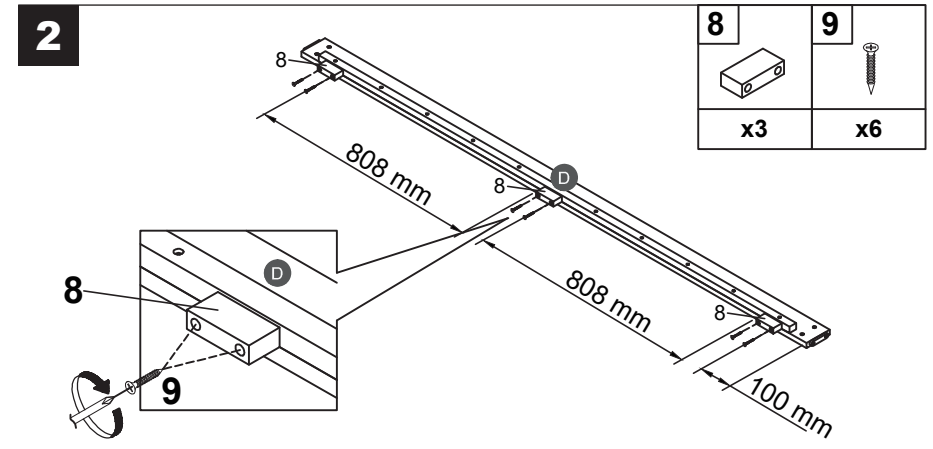
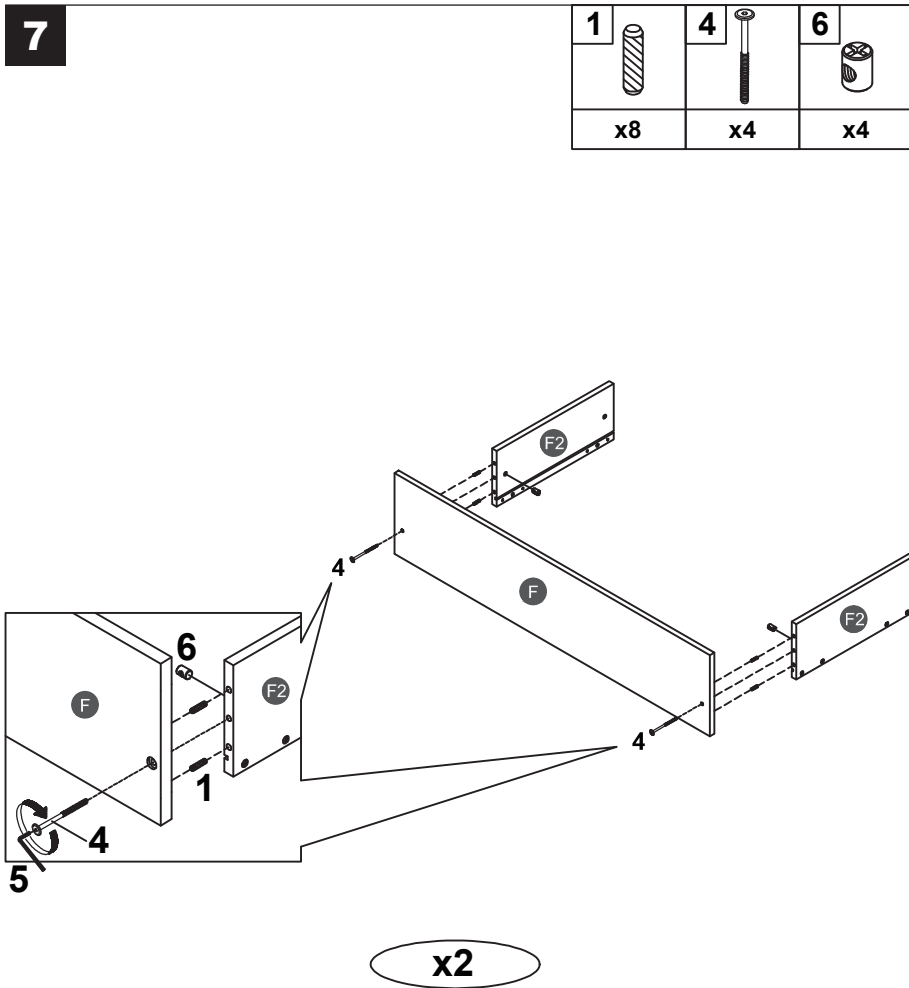

EN: Install drawer stoppers (8) on front side rails (D) by using screws (9).
FR: Installez les butées de tiroir (8) sur les rails latéraux avant (D) à l'aide de vis (9).

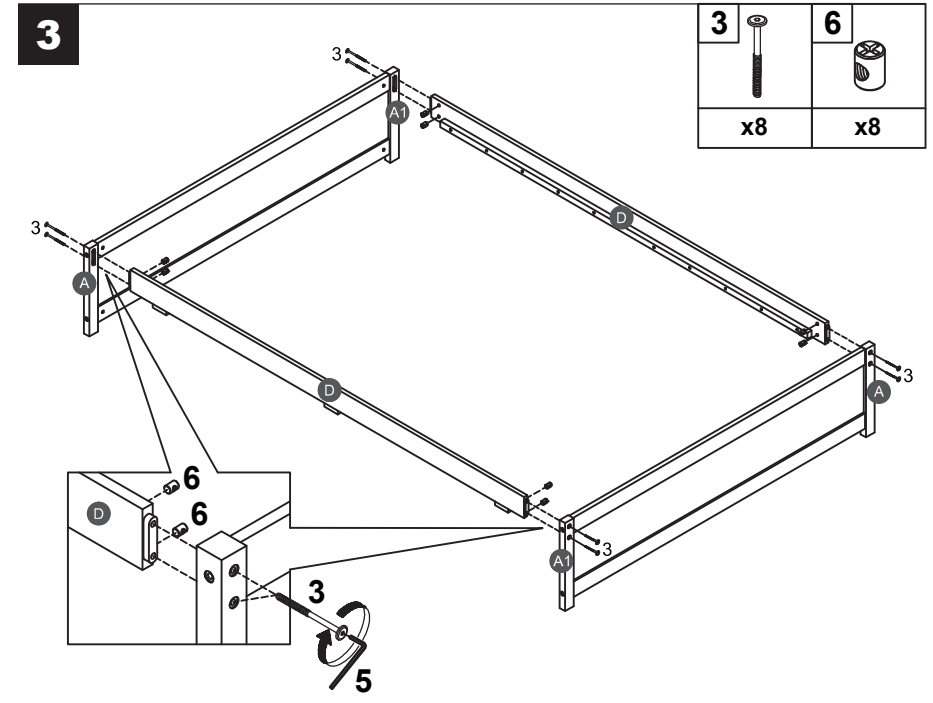

4

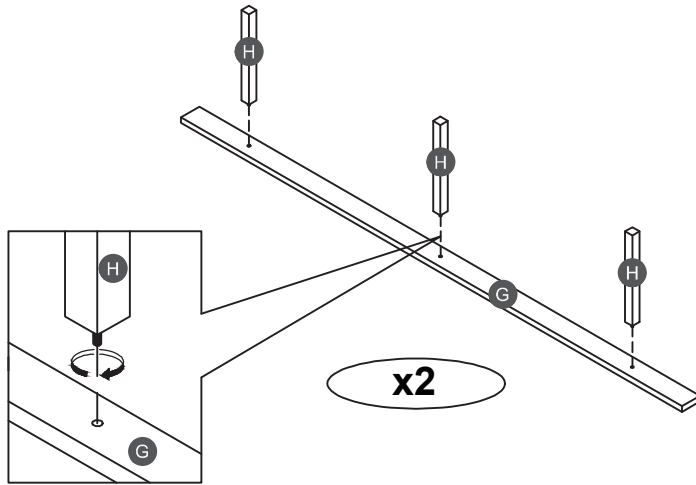

EN: Assemble leg supporters (H) to lower support slats (G) and rotate to secure. Install support slats to bed.

FR: Assemblez les supports de pieds (H) pour abaisser les lattes de support (G) et tournez-les pour les fixer. Installez des lattes de support au lit.

5

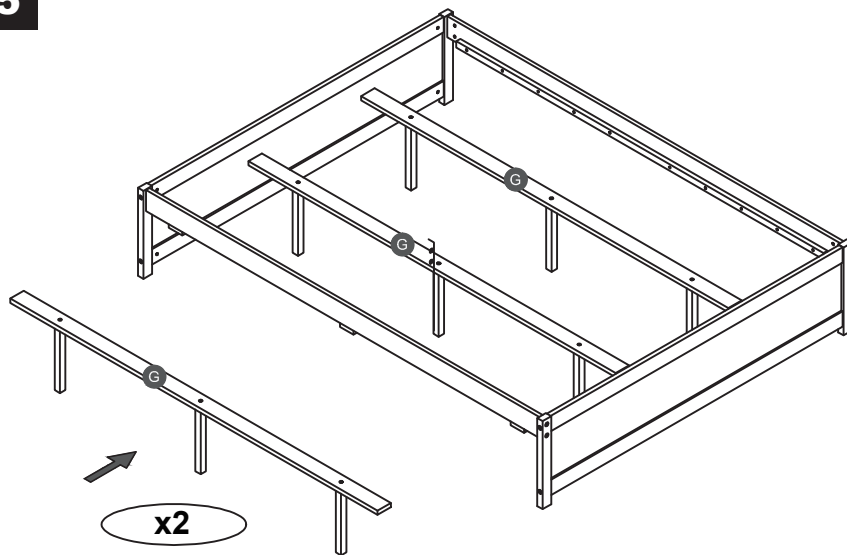

6

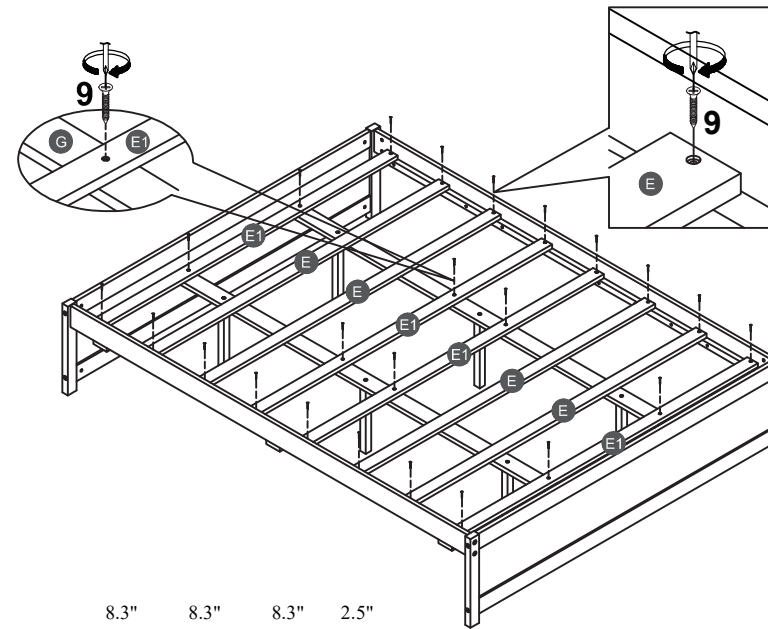

9

x24

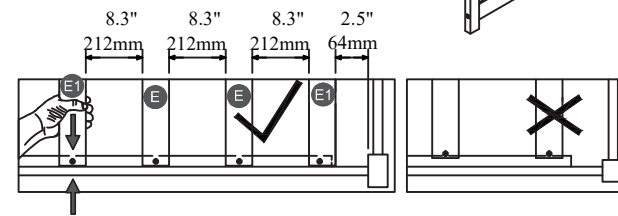

EN: Note: Please make sure the bed slats are close to the side rail before locking the screws to avoid breakage. This step is required for both the left and right sides. Moreover, please do not lock the screws of the bed slats at the outermost edge to avoid damaging

FR: Remarque: Assurez-vous que les lattes du lit sont proches du rail latéral avant de bloquer les vis pour éviter qu'elles ne se cassent. Cette étape est nécessaire pour les côtés gauche et droit. En outre, veuillez ne pas bloquer les vis des lattes de lit sur le bord extérieur pour éviter de les endommager.