

ASSEMBLY INSTRUCTIONS DINING CHAIR

ASSEMBLY
REQUIREMENTS

1-PERSON
ASSEMBLY

45 MINUTES
ASSEMBLY TIME
PER CHAIR
(APPROXIMATE)

TOOLS REQUIRED
(NOT PROVIDED)

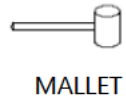

Thank you for purchasing our product!

Please refer and use this assembly instruction to assemble the product. Contact our customer service department in case there are any missing or damage parts or hardware. Replacement parts are normally shipped within 2 or 3 days



PRODUCTS PURCHASED THROUGH OUR AUTHORIZED VENDORS ONLY ARE ELIGIBLE FOR REPLACEMENT PARTS

We appreciate your business!

THIS PRODUCT IS FOR INDOOR AND HOUSEHOLD USE ONLY - NOT FOR COMMERCIAL USE.

ASSEMBLY PREPARATION

1. Remove all packing materials, staples and packing straps from the carton.
2. Refer to Parts List and Hardware List. Ensure all the parts, hardware and quantities are correct before assembly. Contact customer service for missing part.
3. Place all wooden parts on a clean, flat and soft surface (e.g. carpet or rug) to prevent parts from getting scratched.

SAFETY PRECAUTION

1. KEEP ALL HARDWARE PARTS OUT OF REACH OF CHILDREN.
2. DISPOSE PLASTIC PACKAGING MATERIAL IMMEDIATELY TO AVOID ANY RISK OF SUFFOCATION TO CHILDREN AND ANIMALS.

TIPS FOR ASSEMBLY

1. Allow ample room for assembly and in close proximity to where product will be placed.
2. Assemble the product on a surface that does not scratch or damage the exterior gloss and finish of the furniture.
3. Identify all of the parts, hardware and quantities required for each step.
4. During assembly, do not over-tighten any fittings as this may cause damage.
5. DO NOT USE POWER TOOLS TO ASSEMBLE THIS PRODUCT.
6. Always place the product on a flat, level surface.
7. Do not sit or stand on the partially assembled product; only use the product for which it is intended.

CARE AND MAINTENANCE







- Wipe clean with a soft, dry cloth; avoid the use of harsh chemicals or household cleaners as they may damage the exterior finish of the furniture.
- Hardware may loosen over time. Periodically, check that all connections are tight; re-tighten as necessary.
- Solid wood is impacted by heat and humidity fluctuations which may cause small joint separations or hairline cracks; place the furniture away from direct sunlight and air conditioning vents, heating vents or units to protect the furniture.

ASSEMBLY INSTRUCTIONS DINING CHAIR

PARTS LIST (FOR 2 CHAIRS)



NO.	COMPONENT	QTY.
P1	CHAIR SEAT	2
P2	FRONT LEG	4
P3	CHAIR BACK	2

HARDWARE LIST (FOR 2 CHAIRS)

NO.	DESCRIPTION	QTY.	EXTRA
H1	JCBC SCREW M6 X 35 	4	1
H2	JCBC SCREW M6 X 80 	16	1
H3	SPRING WASHER 	20	2
H4	FLAT WASHER 	20	2
H5	ALLEN KEY 	1	
H6	LEG STUD 	8	2

* Extra Hardware For Spare Use

STEP 1

H1 x 2		M6 x 35mm
H3 x 2		
H4 x 2		

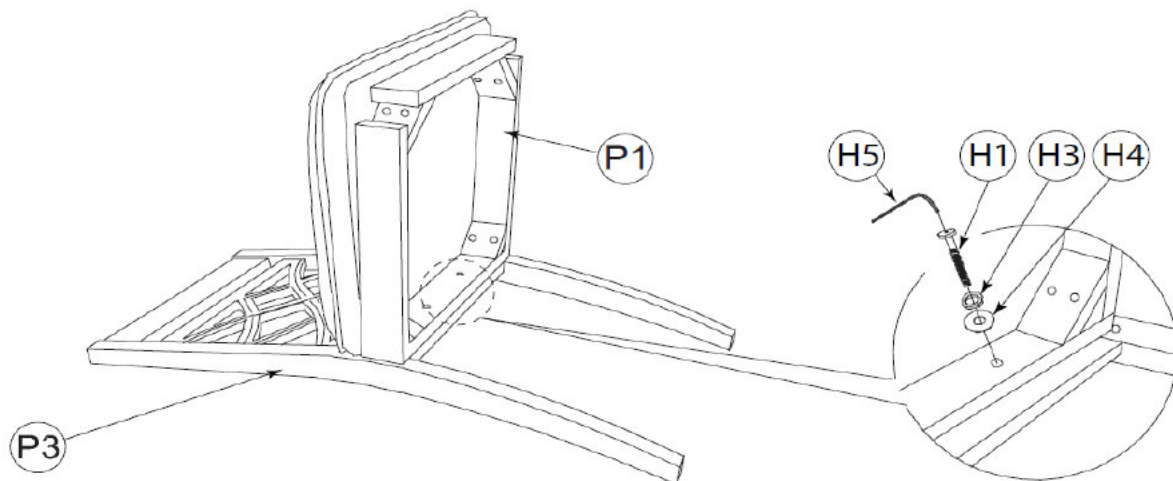



**DO NOT FULLY
TIGHTEN.**

- Place Chair Back (P3) on a flat & soft material that does not scratch or damage the part.
- Place Chair Seat (P1) on (P3) as shown. Fasten the two parts at the center using JCBC Screw (H1) fitted with Spring Washer (H3) and Flat Washer (H4). Use Allen Key (H5) to drive (H1). Do not tighten (H1) completely at this time.

ASSEMBLY INSTRUCTIONS DINING CHAIR

STEP 2

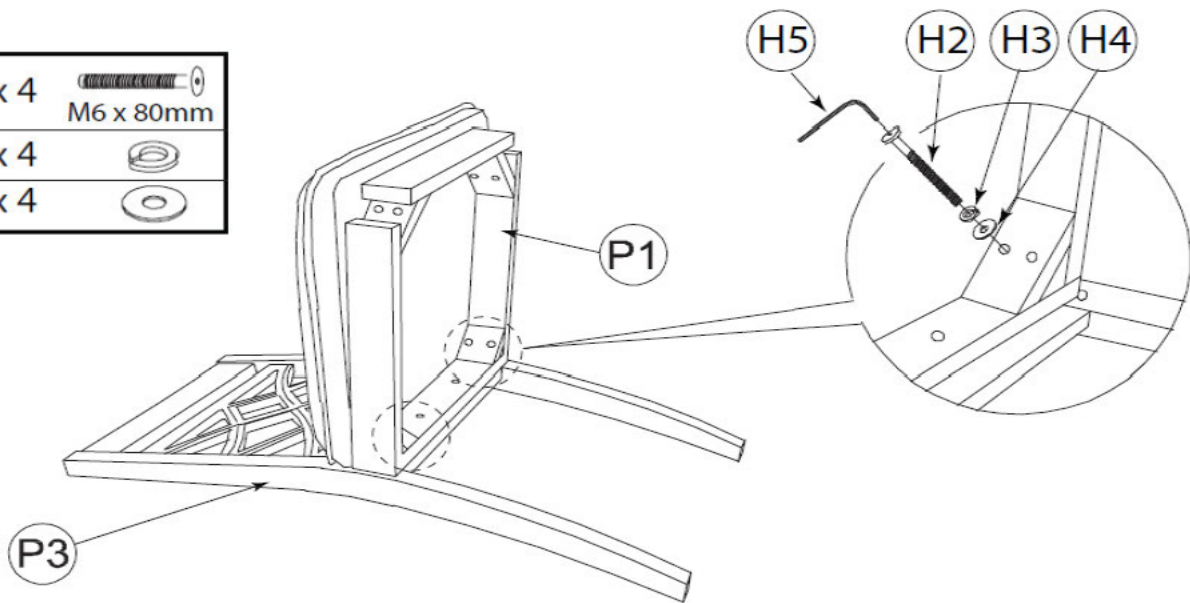

H2 x 4	
M6 x 80mm	
H3 x 4	
H4 x 4	



a) At each rear corner of (P1), align the screw holes on the corner block to the screw holes on each rear leg. Next, insert Screw (H2) fitted with Spring Washer (H3) and Flat Washer (H4) into each of the screw hole. Use Allen Key (H5) to drive (H2). Do not tighten completely until all four screws are in place.

b) Tighten Screw (H1) completely at this time.

STEP 3

H2 x 4	
M6 x 80mm	
H3 x 4	
H4 x 4	

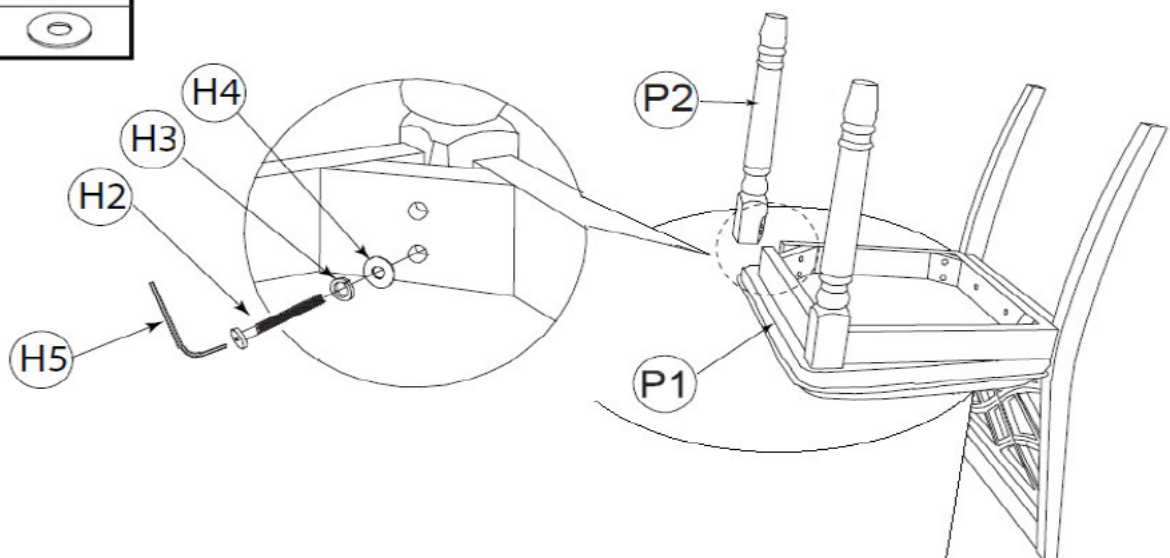

a) Place the assembly from Step 2, bottom-side up as shown on an elevated surface (e.g. table top).

b) Place a Front Leg (P2) against a front corner of (P1) as shown, and align the screw holes on (P2) to the screw holes on front corner block of (P1).

c) Insert Screw (H2) fitted with Spring Washer (H3) and Flat Washer (H4) into each of the screw hole on the corner block. Use Allen Key (H5) to drive (H2). Do not tighten (H2) completely until both screws are in place. Do not over-tighten the screws.

d) Use the same procedure above to install the other Front Leg (P2).

ASSEMBLY INSTRUCTIONS DINING CHAIR

STEP 4

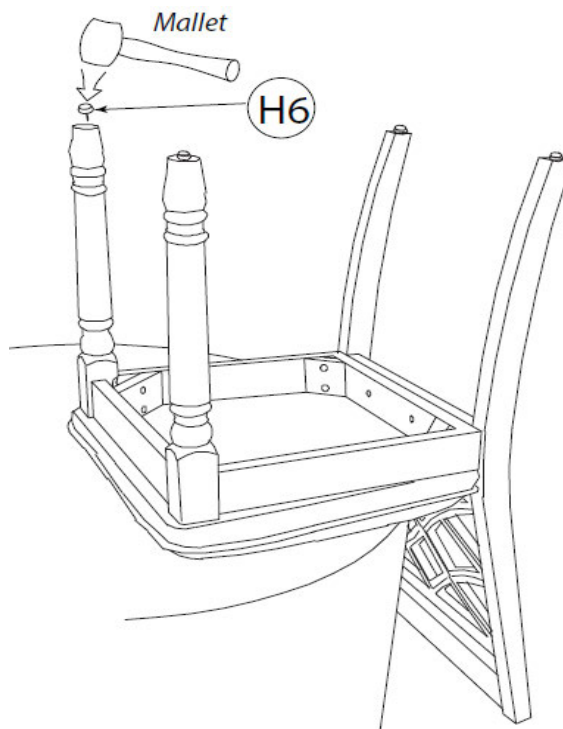
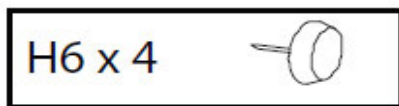

Use a mallet to nail Leg Stud (H6) to the bottom of each leg.

STEP 5

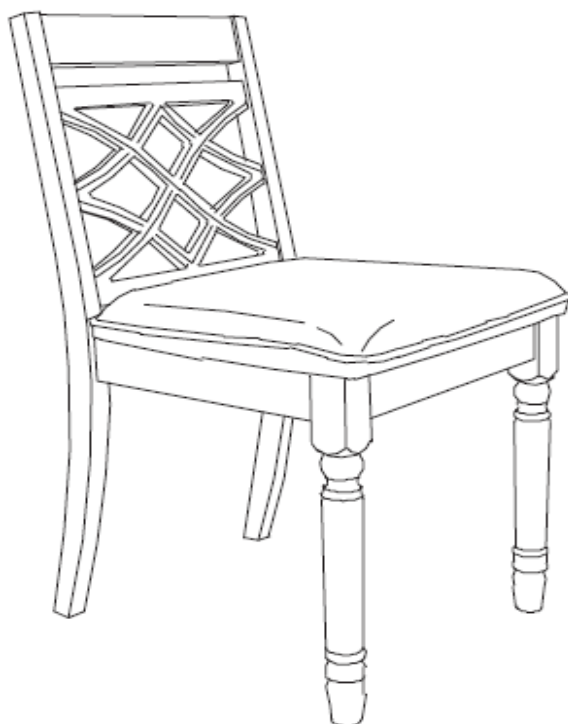

Set the chair right-side up.
The assembly of the chair is complete.