

User Manual

Manual del usuario

Manuel d'utilisateur



LIMITED 90 DAYS WARRANTY**GARANTÍA LIMITADA DE 90 DÍAS****GARANTIE LIMITEE DE 90 JOURS**

This product is covered by a limited warranty that is effective for 90 days from the date of purchase. If, during the limited warranty period, a part is found to be defective or breaks, we will offer replacement parts at no cost to you, the customer. The only exceptions to the warranty include mainframes, table tops, playing surfaces, batteries or tools.

The above warranty will not apply in cases of damages due to improper usage, alteration, misuse, abuse, accidental damage or neglect.

This Limited Warranty gives you specific legal rights and you may also have other rights vary from one State (province) to another.

A PURCHASE RECEIPT (or other proof of purchase) will be required before any warranty service is initiated. For all requests for warranty service, please feel free to contact our Consumer Service Department.

Please be aware of your product's Limited Warranty for the return/refund policy from the store. We, at Medal Sports, cannot handle the product which is out of product's limited warranty since we only provide available parts. Thank you!

PLEASE CONTACT US BEFORE RETURNING THE PRODUCT TO THE STORE!

Este producto está cubierto por una garantía limitada que tiene una vigencia de 90 días a partir de la fecha de su compra. Durante el período de la garantía limitada, si una parte defectuosa o quebrada es encontrada, nosotros ofreceremos una reparación o un reemplazo de la partes sin ningún costo para usted, nuestro cliente. Las únicas excepciones de la garantía incluyen unidades centrales, tableros de mesa, superficies de juego, pilas o herramientas.

La susodicha garantía no se aplicará en los casos de daños debido al uso impropio, la alteración, el mal uso, el abuso, el daño accidental o la negligencia.

Esta garantía limitada le da a usted derechos legales específicos, usted también puede tener otros derechos que varían de un estado (provincia) a otro.

EL RECIBO DE LA COMPRA (U otra prueba de compra) sería requerida antes que cualquier servicio de garantía fuera iniciada. Para todo pedido por servicio de garantía, por favor siéntase libre de ponerse en contacto con nuestro Departamento de Servicio de Consumidor.

Por favor tenga en cuenta sobre la Garantía Limitada de su producto para la política de vuelta/reembolso desde la tienda. Nosotros, Medal Sports, no podemos manejar el producto que está fuera del límite de garantía ya que proporcionamos solamente partes disponibles. ¡Gracias!

¡POR FAVOR PÓNGASE EN CONTACTO CON NOSOTROS ANTES DE DEVOLVER EL PRODUCTO A LA TIENDA!

Ce produit est couvert par une garantie limitée valable 90 jours à compter de la date d'achat. Si pendant cette période une pièce est jugée défectueuse ou se casse, nous la remplacerons gratuitement. Les seules exceptions à la garantie comprennent les armatures principales, les dessus de table, les surfaces de jeu, les piles ou les outils.

La garantie ci-dessus ne s'applique pas en cas de dommages occasionnés par une mauvaise utilisation, une altération, un abus, des un dommage accidentel ou une négligence.

Cette garantie limitée vous accorde des droits légaux spécifiques ainsi que d'autres droits variant d'un état (province) à un autre.

UNE FACTURE D'ACHAT (ou toute autre preuve d'achat) sera exigée avant toute intervention sous garantie. Pour toute demande d'intervention sous garantie, veuillez contacter notre Service Clientèle.

Comprenez votre garantie limitée de produit en ce qui concerne notre politique de retour/remboursement depuis le magasin. Chez Medal Sports, nous ne pouvons pas traiter un produit qui n'est plus sous garantie puisque nous ne pouvons que fournir les pièces disponibles. Remerciements!

VEUILLEZ NOUS CONTACTER AVANT DE RETOURNER LE PRODUIT AU MAGASIN!



WE ARE READY TO HELP

DO NOT RETURN TO STORE

ESTAMOS LISTOS AYUDA

NO DEVOLVERLO A LA TIENDA

NOUS SOMMES PRÊTS À VOUS AIDER

NE PAS RAPPORTER EN MAGASIN

Please Contact | Por favor Contactar | Veuillez contacter

MD SPORTS

Customer Service
Toll Free

Servicio al Cliente
Llamada Gratuita

Service Clientèle
Appel Gratuit

877-472-4296

Mon.-Fri.,
9:00 a.m. to 5:00 p.m. EST

Lunes a Viernes,
9:00 a.m. a 5:00 p.m. ET

Du lundi au vendredi de
9:00 a 17 heures HNE

For additional resources and
Frequently Asked Questions,
please visit us at

Por mayor información y
Preguntas Frecuentes, favor
visitarnos en

Pour toute information
complémentaire ou réponse
aux questions fréquentes,
veuillez vous rendre sur

www.medalsports.com

TOOLS REQUIRED

Phillips Screwdriver - **Not Included**
 Allen Key - **Included**
 Wrench - **Included**

HERRAMIENTAS NECESARIAS

Destornillador Phillips - **No incluido**
 Llave Allen - **Incluido**
 Llave Inglesa - **Incluido**

OUTILS REQUIS

Tournevis cruciforme - **Non inclus**
 Clé hexagonale - **Incluse**
 Clé anglaise - **Incluse**



RECOMMENDED

Electric Screwdrivers may be helpful during assembly; however, please set a low torque and use extreme caution.



RECOMENDADO

Los destornilladores eléctricos pueden ser de gran ayuda durante el ensamblado; sin embargo, por favor ajuste el par de giro bajo y sea extremadamente precavido.



RECOMMANDÉ

Un tournevis électrique peut être utile pour l'assemblage; utilisez cependant une vitesse de rotation lente et avec prudence.

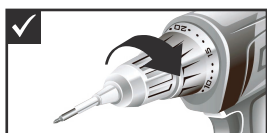

Power Tools: **Set to Low Torque**
 Herramientas eléctricas: **Establecer a baja velocidad**
 Visseuse électrique: **Couple faible**



High Torque Over Tightened
 Una alta velocidad puede apretar demasiado
 Un couple élevé peut créer des dommages

! IMPORTANT NOTICE

1. Please do not sit, climb or lean on the product.
2. Please do not drag the product when moving it in order to avoid damaging the legs.
3. This is not a children's toy.
4. Assembly required.
5. DO NOT over tighten bolts and screws.

! AVISO IMPORTANTE

1. Por favor no se siente, suba o incline sobre el producto.
2. Por favor no arrastre el producto cuando lo mueva de lugar para evitar daño en las patas de la mesa.
3. Este no es un juguete para niños.
4. Se requiere ensamblaje.
5. NO apriete en exceso los tornillos y los pernos.

! NOTE IMPORTANTE

1. Veuillez ne pas vous asseoir, grimper ou vous appuyer sur la produit.
2. Veuillez ne pas déplacer la produit en la tirant pour ne pas endommager les pieds.
3. Ce n'est pas un jeu d'enfant.
4. Assemblage requis.
5. NE PAS serrer excessivement les boulons et les vis.



At least 6 adults needed
 Se necesitan al menos 6 adultos
 Il faut au moins 6 adultes



No children in assembly area
 No deben estar los niños en el area de ensamble
 Pas d'enfants dans la zone d'assemblage



Keep away from pets in assembly area
 Mantener alejados a los animales domesticos del area de ensamble
 Tenir les animaux de compagnie à distance



Do not use or keep product outdoors. For indoor use only. No wet/humid conditions.
 No usar o guardar el producto en el exterior. Solo para uso en interior. No utilizar ni guardar el producto en lugares húmedos o mojados.
 N'utilisez ni ne stockez ce produit en extérieur. Uniquement pour utilisation en intérieur. Ne pas exposer à l'humidité.

CARE INSTRUCTIONS

- To prolong the life of your game, clean your game regularly. Please only use furniture polish spray to clean the exterior surfaces of the product. This will remove dirt, sweat, and other debris that can build up over time and damage the materials.

INSTRUCCIONES DE CUIDADO

- Para prolongar la vida útil de tu juego, límpialo regularmente. Por favor use solamente spray de pulido para muebles para limpiar la superficie exterior del producto. Esto eliminará la suciedad, el sudor y otros desechos que pueden acumularse con el tiempo y dañar los materiales.

INSTRUCTIONS D'ENTRETIEN

- Pour prolonger la durée de vie de votre jeu, nettoyez-le régulièrement. Veuillez utiliser seulement le vernis pour meuble pour nettoyer les surfaces extérieures du produit de jeu. Cela permettra d'éliminer la saleté, la sueur et les autres débris qui peuvent s'accumuler avec le temps et endommager les matériaux.

PARTS IDENTIFIER

IDENTIFICADOR DE PIEZAS

IDENTIFICATEUR DE PIÈCES

PART NUMBER
NÚMERO DE PIEZA
NUMÉRO D'ARTICLE

PART
PIEZA
PIÈCE

PART NAME

1

FOR FIG. 1
PARA LA FIG. 1
POUR LA FIG. 1

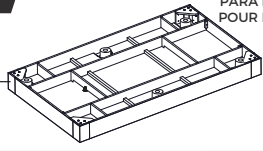







x1

Mainframe	Unidad principal	Unité centrale
-----------	------------------	----------------

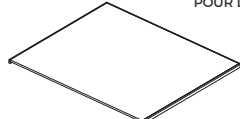
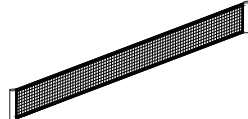
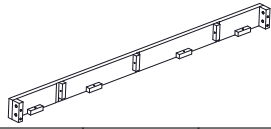
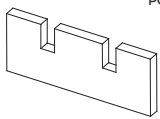
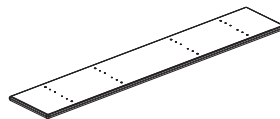
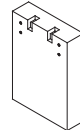
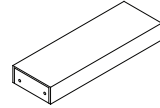
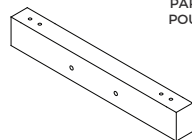
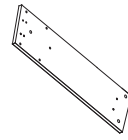
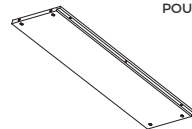
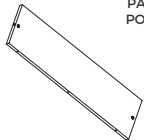
FIG. NUMBER
NÚMERO DE FIG.
NUMÉRO FIG.

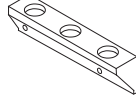
QUANTITY
CANTIDAD
QUANTITÉ

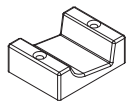
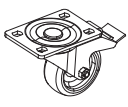

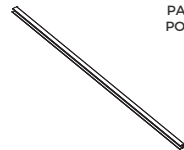
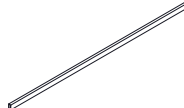
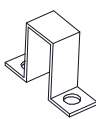
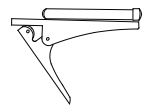
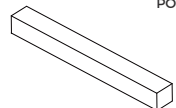

NOM DE LA PIÈCE
NOMBRE DE PIEZA

<p>2</p> <p>FOR FIG. 1 PARA LA FIG. 1 POUR LA FIG. 1</p>  <p>x4</p> <table border="1"> <tr> <td>Leg</td> <td>Pata</td> <td>Pied</td> </tr> </table>	Leg	Pata	Pied	<p>3</p> <p>FOR FIG. 8 PARA LA FIG. 8 POUR LA FIG. 8</p>  <p>x2</p> <table border="1"> <tr> <td>Table Top</td> <td>Tablero de mesa</td> <td>Dessus de table</td> </tr> </table>	Table Top	Tablero de mesa	Dessus de table	<p>4</p> <p>FOR FIG. 9 PARA LA FIG. 9 POUR LA FIG. 9</p>  <p>x1</p> <table border="1"> <tr> <td>Net</td> <td>Red</td> <td>Filet</td> </tr> </table>	Net	Red	Filet	<p>5</p> <p>FOR FIG. 3 PARA LA FIG. 3 POUR LA FIG. 3</p>  <p>x4</p> <table border="1"> <tr> <td>Bench Leg Panel</td> <td>Panel de pata de banco</td> <td>Panneau de jambe de banc</td> </tr> </table>	Bench Leg Panel	Panel de pata de banco	Panneau de jambe de banc
Leg	Pata	Pied													
Table Top	Tablero de mesa	Dessus de table													
Net	Red	Filet													
Bench Leg Panel	Panel de pata de banco	Panneau de jambe de banc													
<p>6</p> <p>FOR FIG. 6 PARA LA FIG. 6 POUR LA FIG. 6</p>  <p>x6</p> <table border="1"> <tr> <td>Bench - Support Board</td> <td>Banco - Tablero de soporte</td> <td>Banc - Plateau de support</td> </tr> </table>	Bench - Support Board	Banco - Tablero de soporte	Banc - Plateau de support	<p>7</p> <p>FOR FIG. 3 PARA LA FIG. 3 POUR LA FIG. 3</p>  <p>x2</p> <table border="1"> <tr> <td>Bench</td> <td>Banco</td> <td>Banc</td> </tr> </table>	Bench	Banco	Banc	<p>8</p> <p>FOR FIG. 4, 6 PARA LA FIG. 4, 6 POUR LA FIG. 4, 6</p>  <p>x4</p> <table border="1"> <tr> <td>Bench Leg</td> <td>Pata de banco</td> <td>Jambe de banc</td> </tr> </table>	Bench Leg	Pata de banco	Jambe de banc	<p>9</p> <p>FOR FIG. 12 PARA LA FIG. 12 POUR LA FIG. 12</p>  <p>x1</p> <table border="1"> <tr> <td>Cue Rack - Base Panel-A</td> <td>Estante de tacos-panel de base-A</td> <td>Support de queue de billard-panneau inférieur-A</td> </tr> </table>	Cue Rack - Base Panel-A	Estante de tacos-panel de base-A	Support de queue de billard-panneau inférieur-A
Bench - Support Board	Banco - Tablero de soporte	Banc - Plateau de support													
Bench	Banco	Banc													
Bench Leg	Pata de banco	Jambe de banc													
Cue Rack - Base Panel-A	Estante de tacos-panel de base-A	Support de queue de billard-panneau inférieur-A													
<p>10</p> <p>FOR FIG. 12 PARA LA FIG. 12 POUR LA FIG. 12</p>  <p>x2</p> <table border="1"> <tr> <td>Cue Rack - Leg Base</td> <td>Estante de tacos - Bases de pata</td> <td>Support de queue de billard - Base pied</td> </tr> </table>	Cue Rack - Leg Base	Estante de tacos - Bases de pata	Support de queue de billard - Base pied	<p>11</p> <p>FOR FIG. 11 PARA LA FIG. 11 POUR LA FIG. 11</p>  <p>x2</p> <table border="1"> <tr> <td>Cue Rack - End Apron</td> <td>Estante de tacos - Delantal final</td> <td>Support de queue de billard - Tablier final</td> </tr> </table>	Cue Rack - End Apron	Estante de tacos - Delantal final	Support de queue de billard - Tablier final	<p>12</p> <p>FOR FIG. 10 PARA LA FIG. 10 POUR LA FIG. 10</p>  <p>x2</p> <table border="1"> <tr> <td>Cue Rack - Side Apron</td> <td>Estante de tacos - Delantal lateral</td> <td>Support de queue de billard - Tablier latéral</td> </tr> </table>	Cue Rack - Side Apron	Estante de tacos - Delantal lateral	Support de queue de billard - Tablier latéral	<p>13</p> <p>FOR FIG. 10 PARA LA FIG. 10 POUR LA FIG. 10</p>  <p>x1</p> <table border="1"> <tr> <td>Cue Rack - Base Panel-B</td> <td>Estante de tacos-panel de base-B</td> <td>Support de queue de billard-panneau inférieur-B</td> </tr> </table>	Cue Rack - Base Panel-B	Estante de tacos-panel de base-B	Support de queue de billard-panneau inférieur-B
Cue Rack - Leg Base	Estante de tacos - Bases de pata	Support de queue de billard - Base pied													
Cue Rack - End Apron	Estante de tacos - Delantal final	Support de queue de billard - Tablier final													
Cue Rack - Side Apron	Estante de tacos - Delantal lateral	Support de queue de billard - Tablier latéral													
Cue Rack - Base Panel-B	Estante de tacos-panel de base-B	Support de queue de billard-panneau inférieur-B													
<p>14</p> <p>FOR FIG. 2 PARA LA FIG. 2 POUR LA FIG. 2</p>  <p>x4</p> <table border="1"> <tr> <td>Leg Leveler</td> <td>Nivelador de pata</td> <td>Niveleur de pied</td> </tr> </table>	Leg Leveler	Nivelador de pata	Niveleur de pied	<p>15</p> <p>FOR FIG. 11 PARA LA FIG. 11 POUR LA FIG. 11</p>  <p>x2</p> <table border="1"> <tr> <td>Table Top Lock</td> <td>Bloqueo de tablero de mesa</td> <td>Serrure de dessus de table</td> </tr> </table>	Table Top Lock	Bloqueo de tablero de mesa	Serrure de dessus de table	<p>16</p> <p>FOR FIG. 13 PARA LA FIG. 13 POUR LA FIG. 13</p>  <p>x2</p> <table border="1"> <tr> <td>Cue Mount</td> <td>Soporte de taquera</td> <td>Monture de queue</td> </tr> </table>	Cue Mount	Soporte de taquera	Monture de queue	<p>17</p> <p>FOR FIG. 13 PARA LA FIG. 13 POUR LA FIG. 13</p>  <p>x4</p> <table border="1"> <tr> <td>Cue Clip</td> <td>Clip de caña</td> <td>Clip de queue</td> </tr> </table>	Cue Clip	Clip de caña	Clip de queue
Leg Leveler	Nivelador de pata	Niveleur de pied													
Table Top Lock	Bloqueo de tablero de mesa	Serrure de dessus de table													
Cue Mount	Soporte de taquera	Monture de queue													
Cue Clip	Clip de caña	Clip de queue													
<p>18</p> <p>FOR FIG. 13 PARA LA FIG. 13 POUR LA FIG. 13</p>  <p>x4</p> <table border="1"> <tr> <td>Table Top Bracket</td> <td>Soporte para superficie de mesa</td> <td>Support de table sup</td> </tr> </table>	Table Top Bracket	Soporte para superficie de mesa	Support de table sup	<p>19</p> <p>FOR FIG. 12 PARA LA FIG. 12 POUR LA FIG. 12</p>  <p>x2</p> <table border="1"> <tr> <td>Caster with Lock</td> <td>Ruedecita con Cerradura</td> <td>Roulette avec verrou</td> </tr> </table>	Caster with Lock	Ruedecita con Cerradura	Roulette avec verrou	<p>20</p> <p>FOR FIG. 12 PARA LA FIG. 12 POUR LA FIG. 12</p>  <p>x2</p> <table border="1"> <tr> <td>Caster</td> <td>Rueda</td> <td>Roulette</td> </tr> </table>	Caster	Rueda	Roulette	<p>21</p> <p>FOR FIG. 8 PARA LA FIG. 8 POUR LA FIG. 8</p>  <p>x1</p> <table border="1"> <tr> <td>Trim Strip</td> <td>Fleje de adorno</td> <td>Bande garniture</td> </tr> </table>	Trim Strip	Fleje de adorno	Bande garniture
Table Top Bracket	Soporte para superficie de mesa	Support de table sup													
Caster with Lock	Ruedecita con Cerradura	Roulette avec verrou													
Caster	Rueda	Roulette													
Trim Strip	Fleje de adorno	Bande garniture													
<p>22</p> <p>FOR FIG. 5 PARA LA FIG. 5 POUR LA FIG. 5</p>  <p>x4</p> <table border="1"> <tr> <td>Cross Bar</td> <td>Barra transversal</td> <td>Barre transversale</td> </tr> </table>	Cross Bar	Barra transversal	Barre transversale	<p>23</p> <p>FOR FIG. 7 PARA LA FIG. 7 POUR LA FIG. 7</p>  <p>x16</p> <table border="1"> <tr> <td>Bracket</td> <td>Sporte</td> <td>Support</td> </tr> </table>	Bracket	Sporte	Support	<p>24</p> <p>FOR FIG. 9 PARA LA FIG. 9 POUR LA FIG. 9</p>  <p>x2</p> <table border="1"> <tr> <td>Net Post</td> <td>Poste de red</td> <td>Poteau du filet</td> </tr> </table>	Net Post	Poste de red	Poteau du filet	<p>25</p> <p>FOR FIG. 8 PARA LA FIG. 8 POUR LA FIG. 8</p>  <p>x1</p> <table border="1"> <tr> <td>Table Tennis Support</td> <td>Soporte de tenis de mesa</td> <td>Support de tennis de table</td> </tr> </table>	Table Tennis Support	Soporte de tenis de mesa	Support de tennis de table
Cross Bar	Barra transversal	Barre transversale													
Bracket	Sporte	Support													
Net Post	Poste de red	Poteau du filet													
Table Tennis Support	Soporte de tenis de mesa	Support de tennis de table													

ACCESSORIES

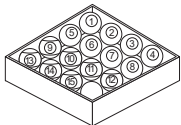
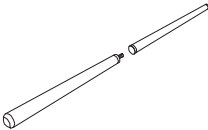
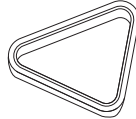
ACCESORIOS

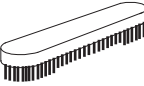









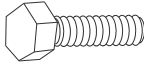

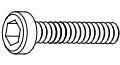

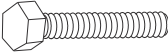
ACCESSOIRES

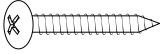
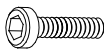
26  x1			27  x2			28  x1			29  x2		
Billiard Ball Set	Bola de billar	Ensemble boules de billard	Cue	Taco	Queue de billard	Triangle	Triángulo	Triangle	Chalk	Tiza	Craie
30  x1			31  x2			32  x2					
Brush	Cepillo	Brosse	Table Tennis Ball	Bola de tenis de mesa	Balle de tennis de table	Table Tennis Paddle	Paleta de tenis de mesa	Raquette de tennis de table			

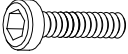
HARDWARE

HARDWARE

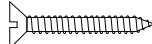
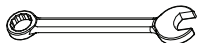

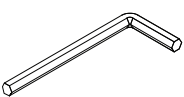

MÉTAUX

A1  x12 FOR FIG. 1 PARA LA FIG. 1 POUR LA FIG. 1			A2  x12 FOR FIG. 1 PARA LA FIG. 1 POUR LA FIG. 1			A3  x16 FOR FIG. 3 PARA LA FIG. 3 POUR LA FIG. 3			A4  x74 FOR FIG. 3, 7, 11, 12 PARA LA FIG. 3, 7, 11, 12 POUR LA FIG. 3, 7, 11, 12		
M12x30mm Bolt	Perno M12x30mm	Boulon M12x30mm	M12 Washer	Arandela M12	Rondelle M12	1/4"x1-3/4" Bolt	Perno 1/4"x1-3/4"	Boulon 1/4"x1-3/4"	1/4" Washer	Arandela 1/4"	Rondelle 1/4"
A5  x16 FOR FIG. 4, 6 PARA LA FIG. 4, 6 POUR LA FIG. 4, 6			A6  x24 FOR FIG. 4, 6, 11, 12 PARA LA FIG. 4, 6, 11, 12 POUR LA FIG. 4, 6, 11, 12			A7  x12 FOR FIG. 7 PARA LA FIG. 7 POUR LA FIG. 7			A8  x48 FOR FIG. 7, 12 PARA LA FIG. 7, 12 POUR LA FIG. 7, 12		
5/16"x1-3/4" Bolt	Perno 5/16"x1-3/4"	Boulon 5/16"x1-3/4"	5/16" Washer	Arandela 5/16"	Rondelle 5/16"	T4x1-1/4" Screw	Tornillo T4x1-1/4"	Vis T4x1-1/4"	1/4"x3/4" Bolt	Perno 1/4"x3/4"	Boulon 1/4"x3/4"
A9  x6 FOR FIG. 10 PARA LA FIG. 10 POUR LA FIG. 10			A10  x10 FOR FIG. 11 PARA LA FIG. 11 POUR LA FIG. 11			A11  x2 FOR FIG. 11 PARA LA FIG. 11 POUR LA FIG. 11			A12  x2 FOR FIG. 11 PARA LA FIG. 11 POUR LA FIG. 11		
T4x1" Screw	Tornillo T4x1"	Vis T4x1"	1/4"x2-1/4" Bolt	Perno 1/4"x2-1/4"	Boulon 1/4"x2-1/4"	5/16"x1-1/8" Bolt	Perno 5/16"x1-1/8"	Boulon 5/16"x1-1/8"	5/16" Nut	Tuerca 5/16"	Écrou 5/16"
A13  x4 FOR FIG. 12 PARA LA FIG. 12 POUR LA FIG. 12			A14  x12 FOR FIG. 13 PARA LA FIG. 13 POUR LA FIG. 13			A15  x8 FOR FIG. 13 PARA LA FIG. 13 POUR LA FIG. 13			A16  x1		
5/16"x3-1/2" Bolt	Perno 5/16"x3-1/2"	Boulon 5/16"x3-1/2"	F3x14mm Screw	Tornillo F3x14mm	Vis F3x14mm	F3x1" Screw	Tornillo F3x1"	Vis F3x1"	Wrench - A	Llave inglesa - A	Clé anglaise - A
A17  x1			A18  x1								
Wrench - B	Llave inglesa - B	Clé anglaise - B	Allen Key	Llave Allen	Clé hexagonale						

PRE-INSTALLED PARTS

PIEZAS PREINSTALADAS

PIÈCES PRÉINSTALLÉES

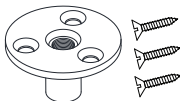
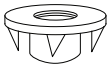
P1  FOR FIG. 10 PARA LA FIG. 10 POUR LA FIG. 10 x10			P2  FOR FIG. 1 PARA LA FIG. 1 POUR LA FIG. 1 x2			P3  FOR FIG. 1 PARA LA FIG. 1 POUR LA FIG. 1 x4			P4  FOR FIG. 1 PARA LA FIG. 1 POUR LA FIG. 1 x6		
Barrel Nut	Tuerca de barril	Écrou à manchon	Adjustable Bracket	Corchete regulable	Support réglable	Round Nut with Screws - A	Tuerca redonda con tornillos - A	Écrou rond avec vis - A	Pocket	Bolsillo	Poche
P5  FOR FIG. 4, 6 PARA LA FIG. 4, 6 POUR LA FIG. 4, 6 x16			P6  FOR FIG. 1 PARA LA FIG. 1 POUR LA FIG. 1 x12			P7  FOR FIG. 12 PARA LA FIG. 12 POUR LA FIG. 12 x4					
Pad	Almohadilla	Bloc	Round Nut with Screws - B	Tuerca redonda con tornillos - B	Écrou rond avec vis - B	Nut	Tuerca	Écrou en			

BEFORE ASSEMBLY

1. Find a clean, level place to begin the assembly of your product.
2. Verify that you have all listed parts as shown on the part list pages. If any parts are missing, call our customer service.

ANTES DE MONTAR

1. Encuentre un lugar limpio y nivelado para comenzar el ensamblaje del producto.
2. Compruebe que tenga todas las piezas que se muestran en la lista de piezas. Si falta alguna pieza, llame a nuestro servicio al cliente.

AVANT L'ASSEMBLAGE







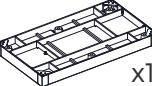

1. Trouvez un endroit propre et plat pour commencer à assembler votre produit.
2. Vérifiez que vous avez toutes les pièces énumérées comme indiqué sur les pages de liste des pièces. S'il y a des pièces qui manquent, appelez notre service à la clientèle.

ASSEMBLY

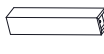
MONTAJE

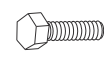
ASSEMBLAGE

FIG. 1

- 1  x1
- P2  x2
- P4  x6
- 2  x4
- P3  x4
- P6  x12
- A1  x12
- A2  x12
- A16  x1
- A17  x1

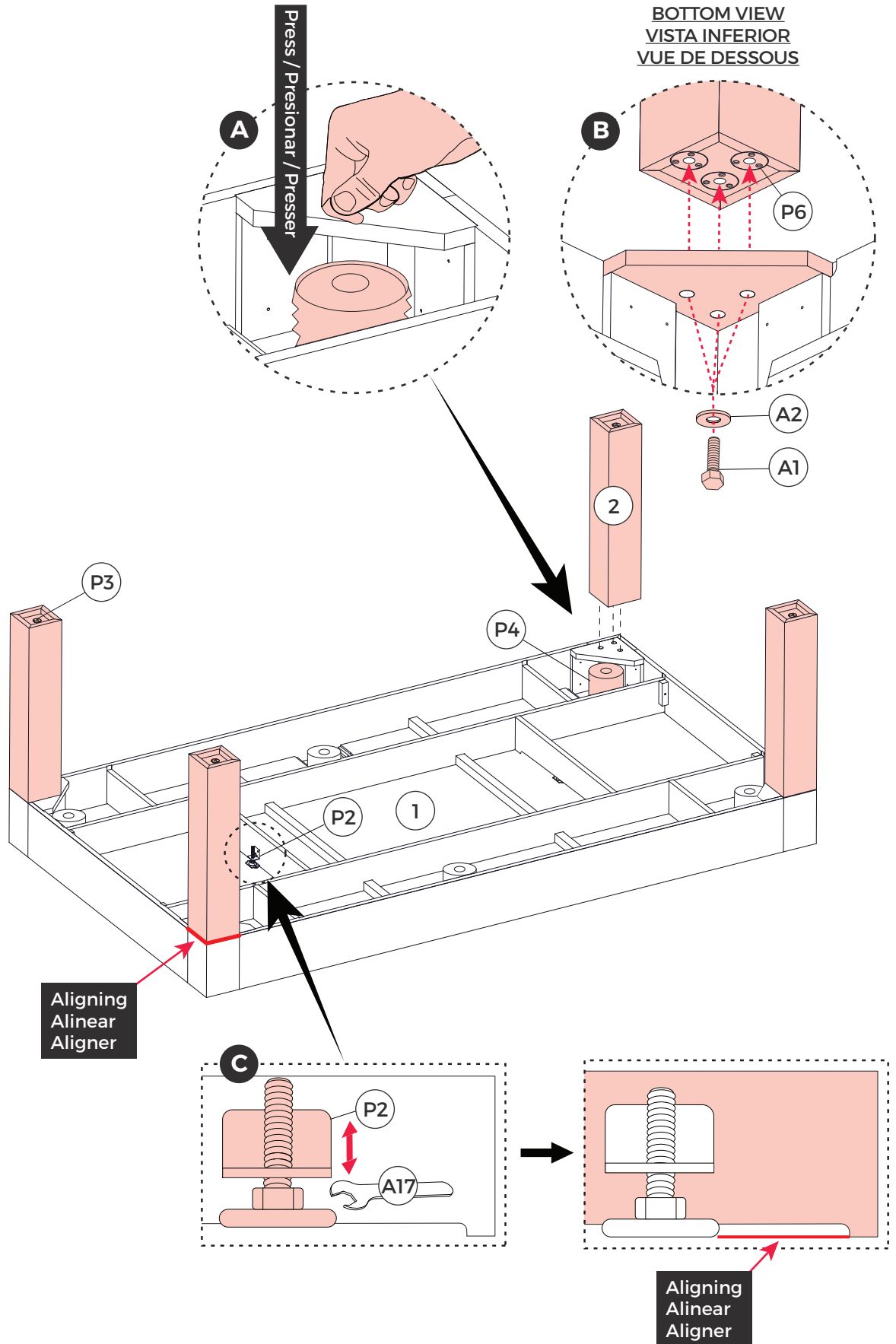

ASSEMBLY

MONTAJE

ASSEMBLAGE

FIG. 2



x4

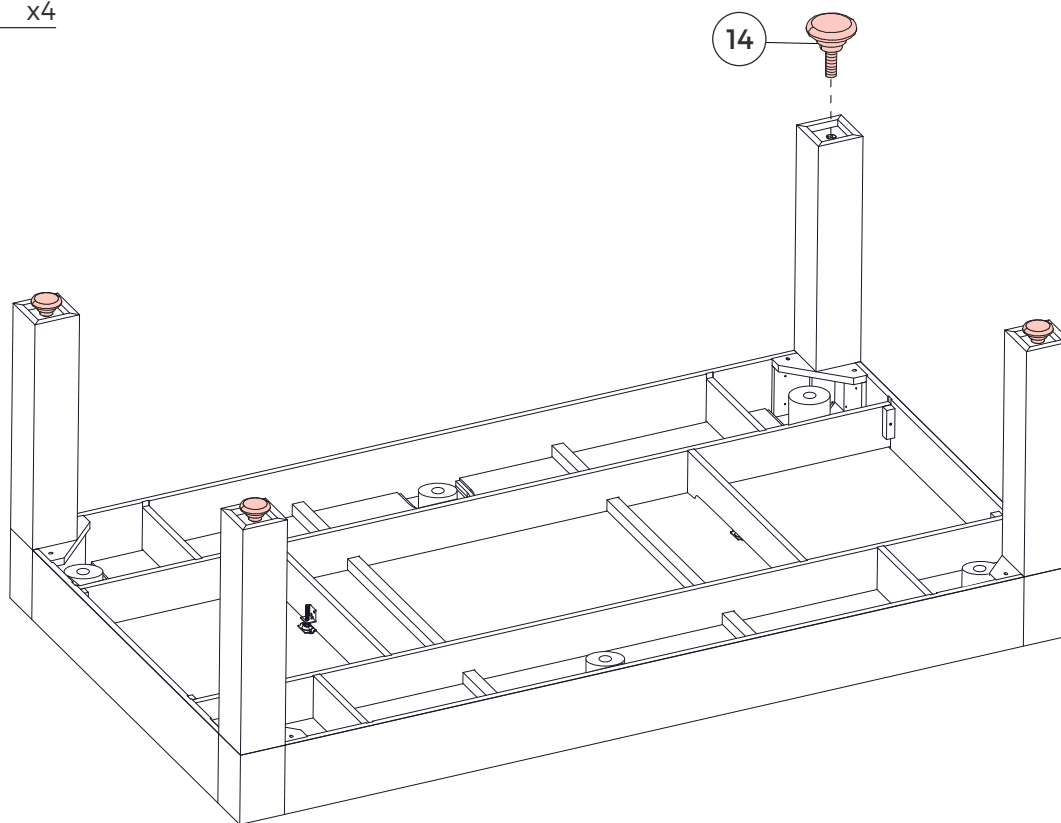

Note: Go back and make sure that all connections are tight.
 Nota: Vuelva y asegúrese que todas las conexiones están apretadas.
 Note : Revérifiez que toutes les connexions sont bien serrées.

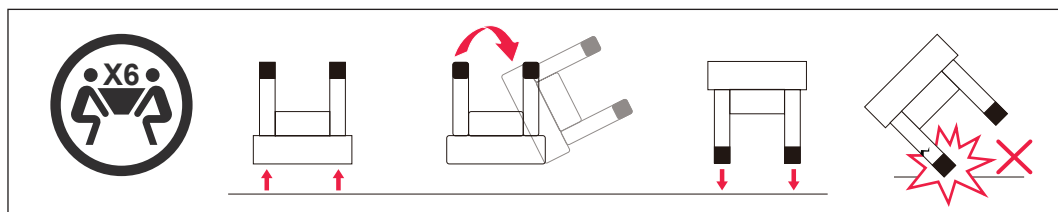
**⚠ CAUTION**

1. Lift the table off the ground.
2. Turn the table over.
3. Place it on all feet at the same time on the ground.

⚠ PRECAUCIÓN

1. Levante la mesa del suelo.
2. Voltee la mesa.
3. Coloque las patas de la mesa sobre el piso al mismo tiempo.

⚠ ATTENTION

1. Soulevez la table du sol.
2. Retournez-la.
3. Placez ses pieds sur le sol simultanément.

HOW TO LEVEL YOUR TABLE

CÓMO NIVELAR SU MESA

COMMENT NIVELER VOTRE TABLE

STEP 1 PASO 1 ÉTAPE 1

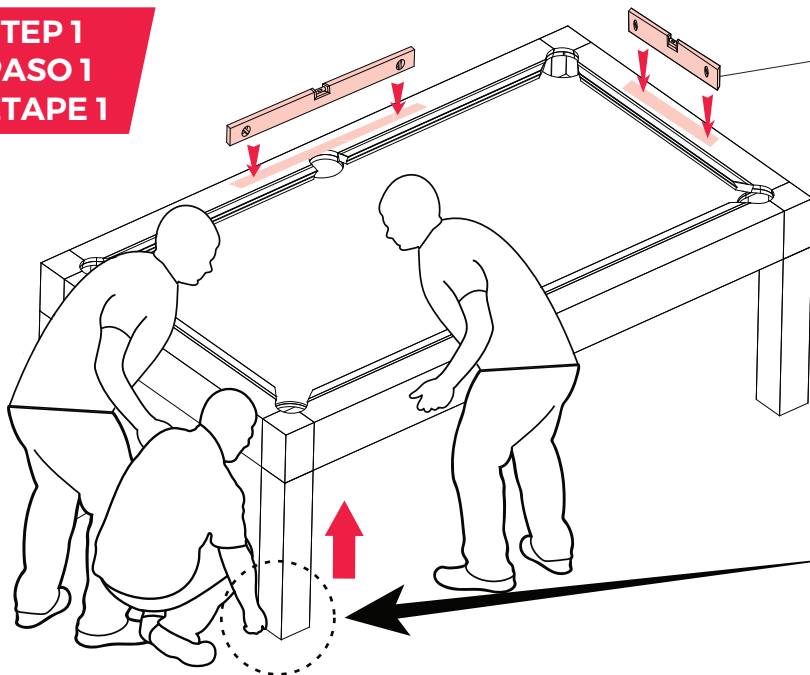

Level (Not included)
Nivel (No incluido)
Niveau (Non inclus)

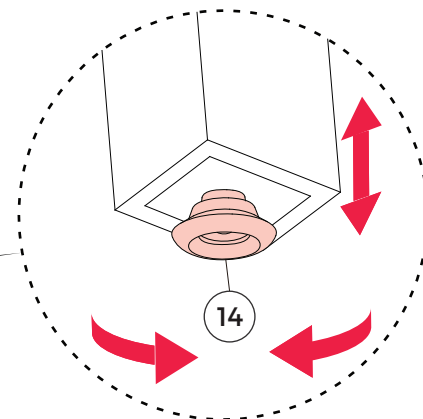

STEP 2 PASO 2 ÉTAPE 2

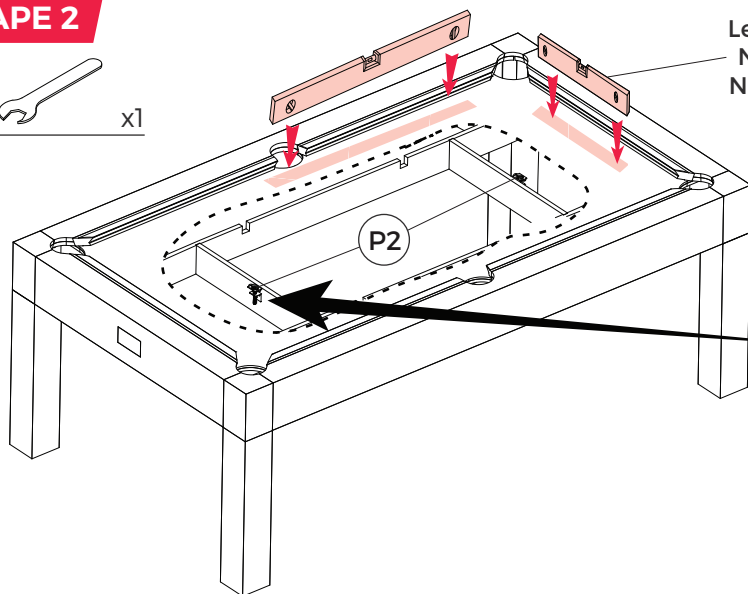

Level (Not included)
Nivel (No incluido)
Niveau (Non inclus)

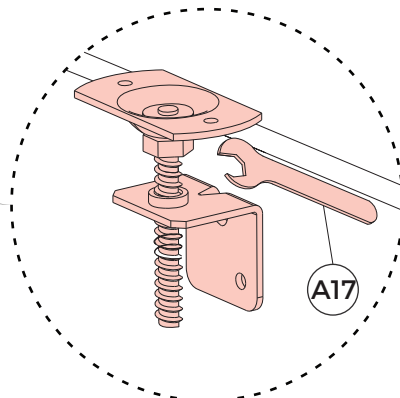

ADJUST CONCAVE TABLE AJUSTAR LA MESA CÓNCAVA POUR AJUSTER LA TABLE CONCAVE

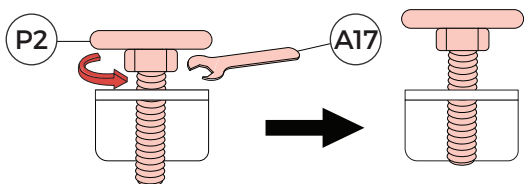

ADJUST CONVEX TABLE AJUSTAR LA MESA CONVEXA POUR AJUSTER LA TABLE CONVEXE

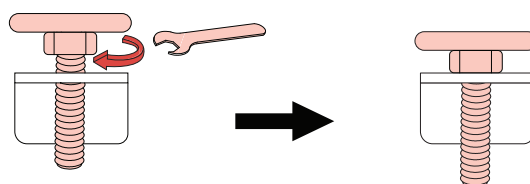

ASSEMBLY

MONTAJE

ASSEMBLAGE

FIG. 3

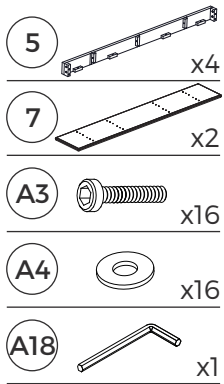

Note: Do NOT tighten the bolts at this step.
 Nota: Que No ajustes los pernos en este paso.
 Note : Ne pas serrer les boulons à ce stage.

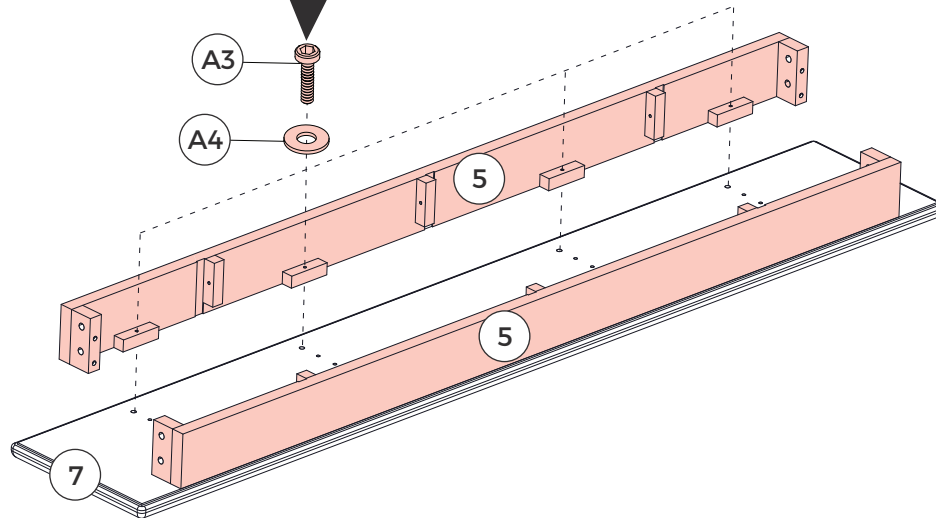

2 SETS
 2 SETS
 2 ENSEMBLES

FIG. 4

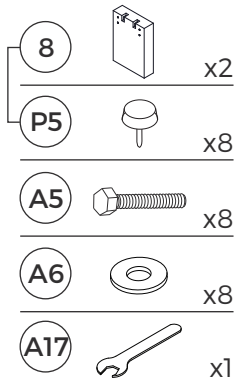

Note: Do NOT tighten the bolts at this step.
 Nota: Que No ajustes los pernos en este paso.
 Note : Ne pas serrer les boulons à ce stage.

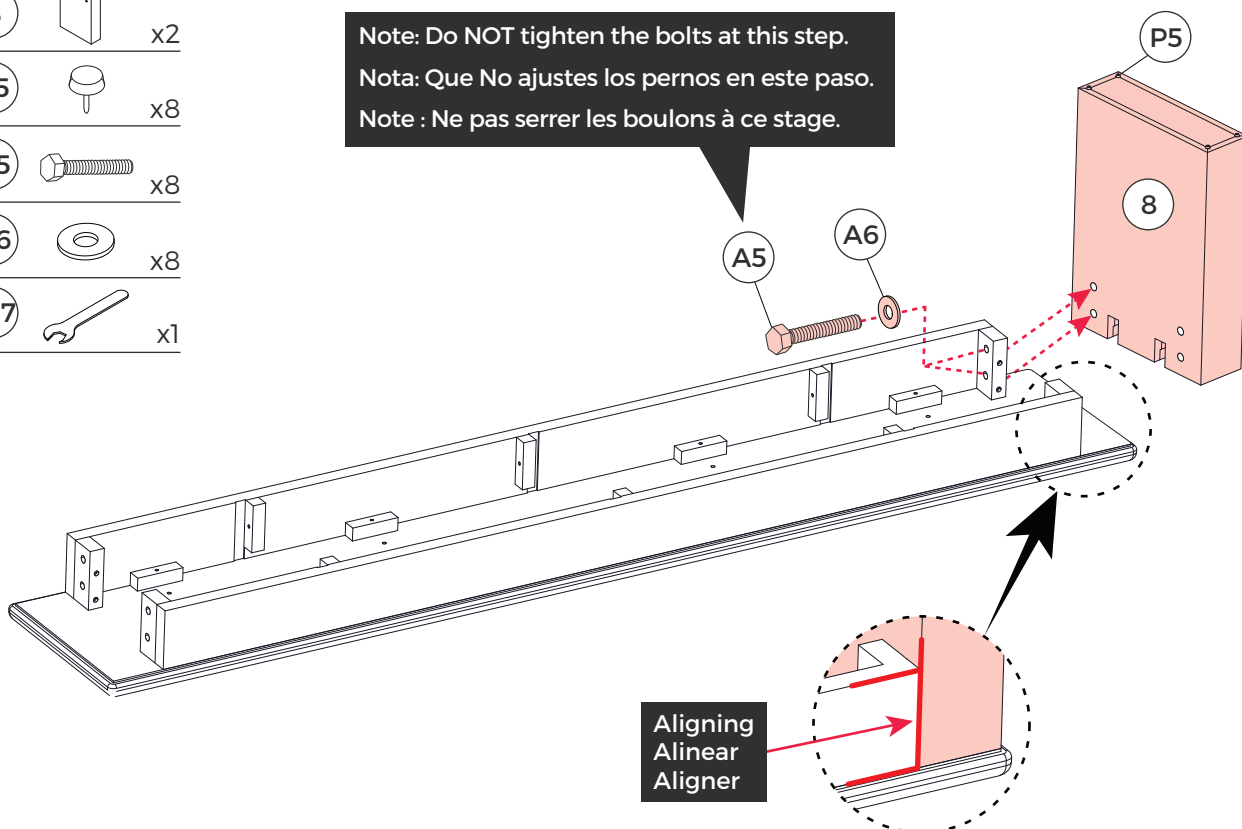

ASSEMBLY

MONTAJE

ASSEMBLAGE

FIG. 5

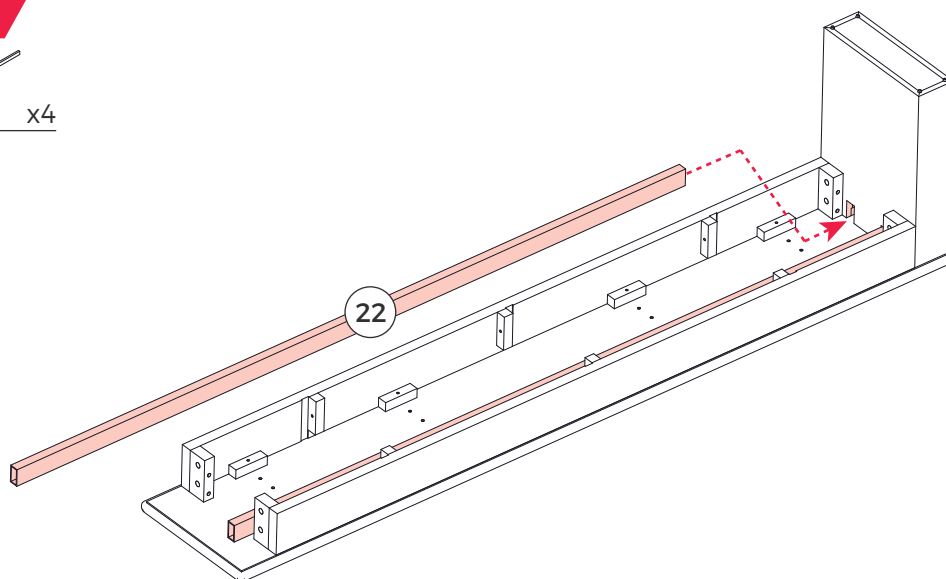
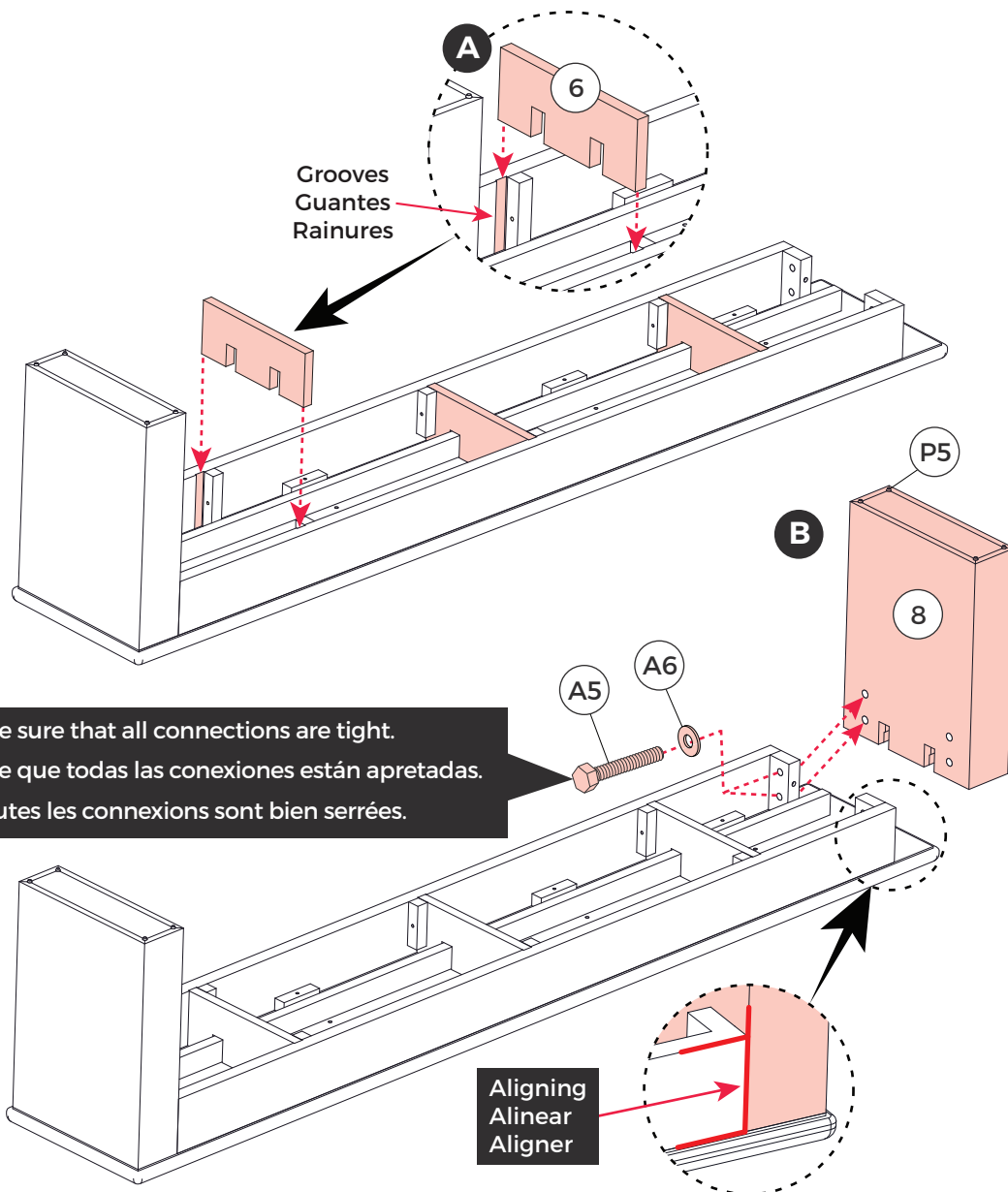
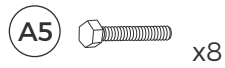
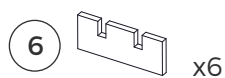

FIG. 6







ASSEMBLY

MONTAJE

ASSEMBLAGE

FIG. 7

-  x16
 x32
 x12
 x32
 x1

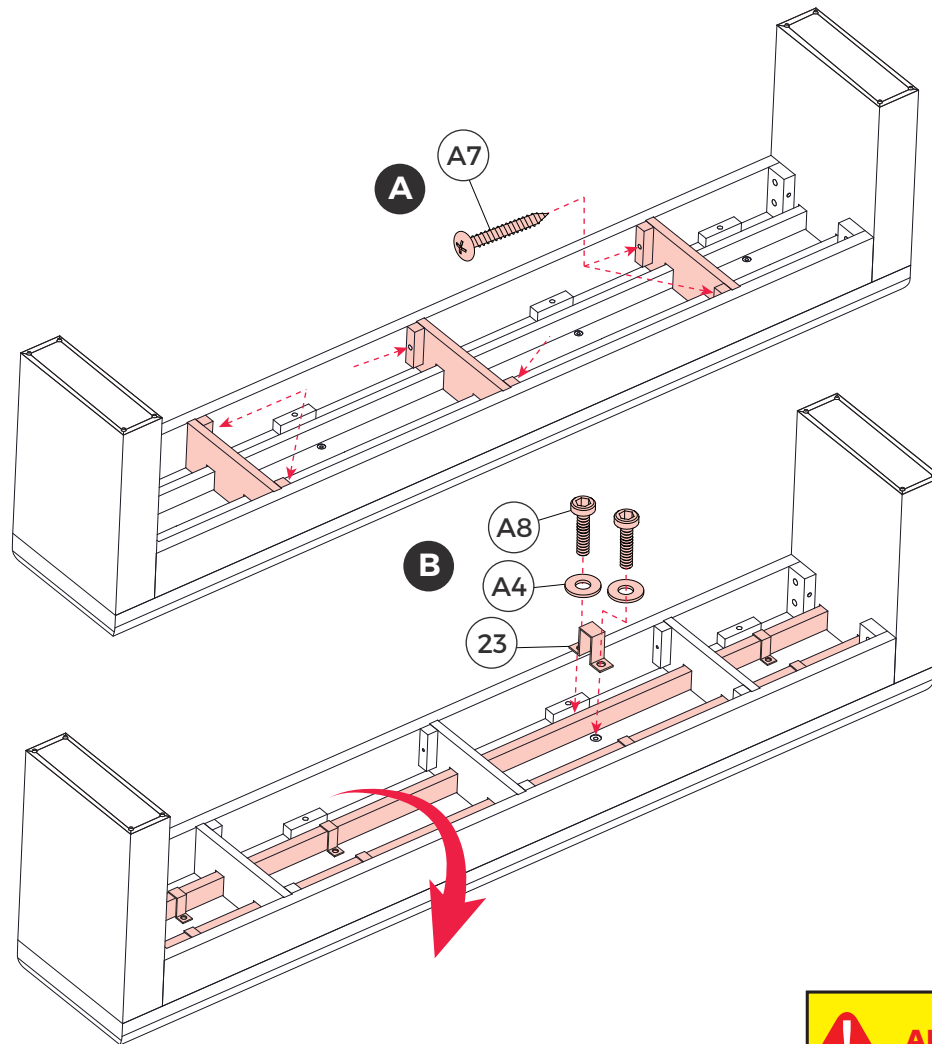
 **TIP**

PER SEAT CAN SUPPORT UP TO:
136 kg / 300 lb

 **CONSEJO**

CADA ASIENTO PUEDE
SOPORTAR HASTA:
136 kg / 300 lb

 **CONSEIL**

CHAQUE SIÈGE SUPPORTERA
JUSQU'À :
136 kg / 300 livres

 **WARNING**

Be careful when moving
the bench on the floor.

 **ADVERTENCIA**

Tenga cuidado al mover el
banco en el piso.

 **ATTENTION**

Soyez prudent lorsque vous
déplacez un banc sur le sol.

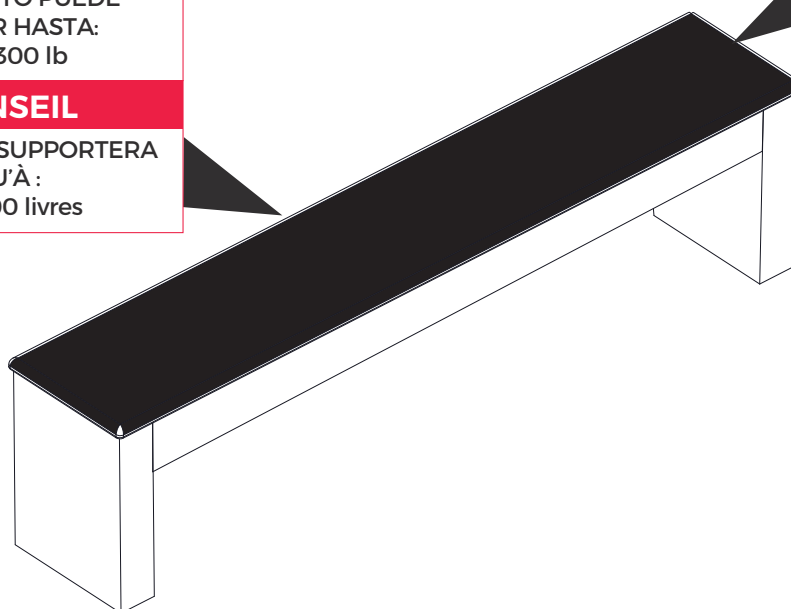



ASSEMBLY

MONTAJE

ASSEMBLAGE

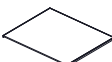
FIG. 8

- 3  x2
- 21  x1
- 25  x1

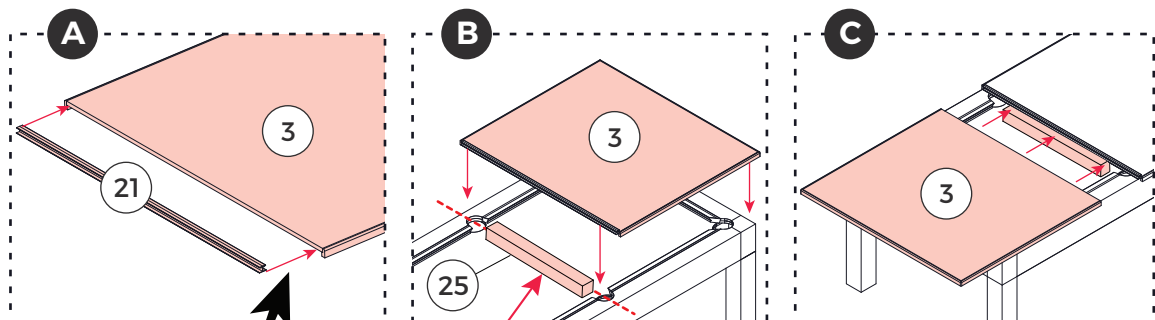

Center
Centro
Centre

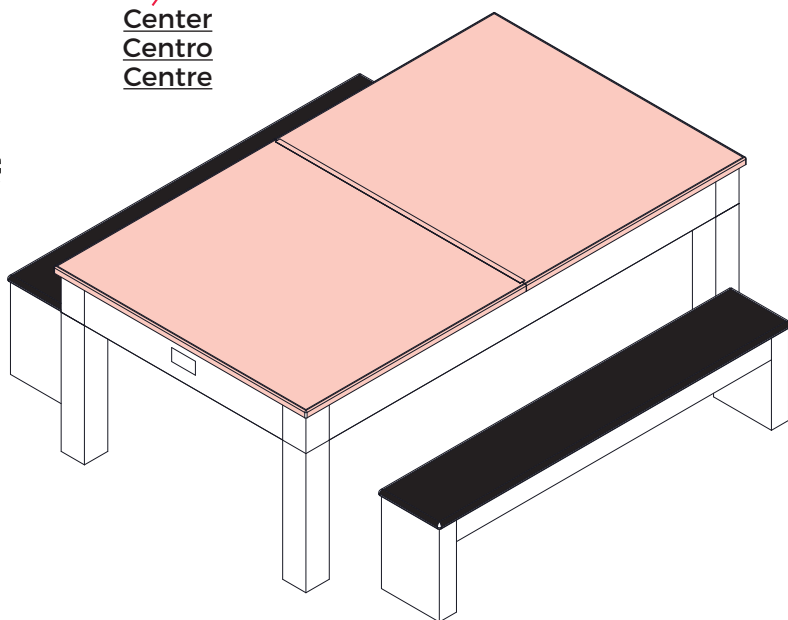
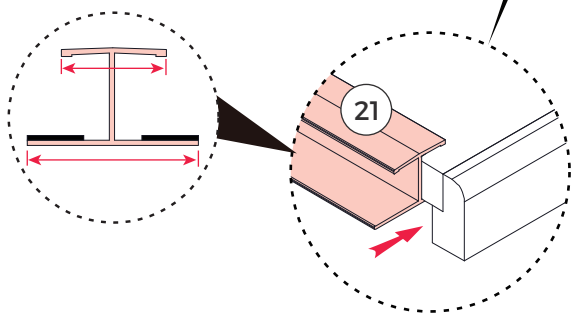

DINING TOP

MESA DE COMEDOR

TABLE À MANGER

FIG. 9

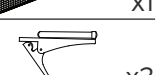
- 4  x1
- 24  x2

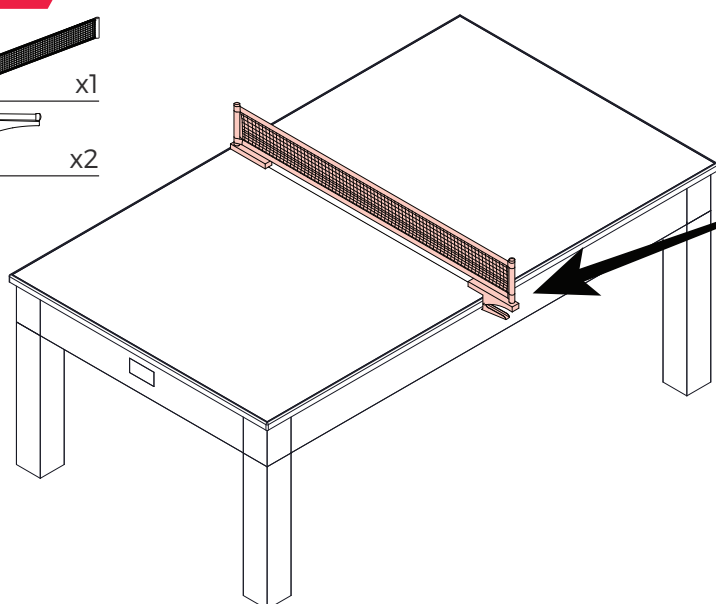

Center
Centro
Centre

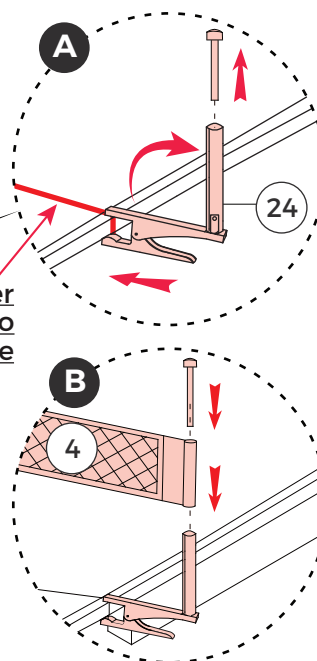

GAME 2: TABLE TENNIS

JUEGO 2: TENIS DE MESA





JEU 2: TENNIS DE TABLE

ASSEMBLY

MONTAJE

ASSEMBLAGE

FIG. 10

- 12  x2
- P1  x8
- 13  x1
- P1  x2
- A9  x6

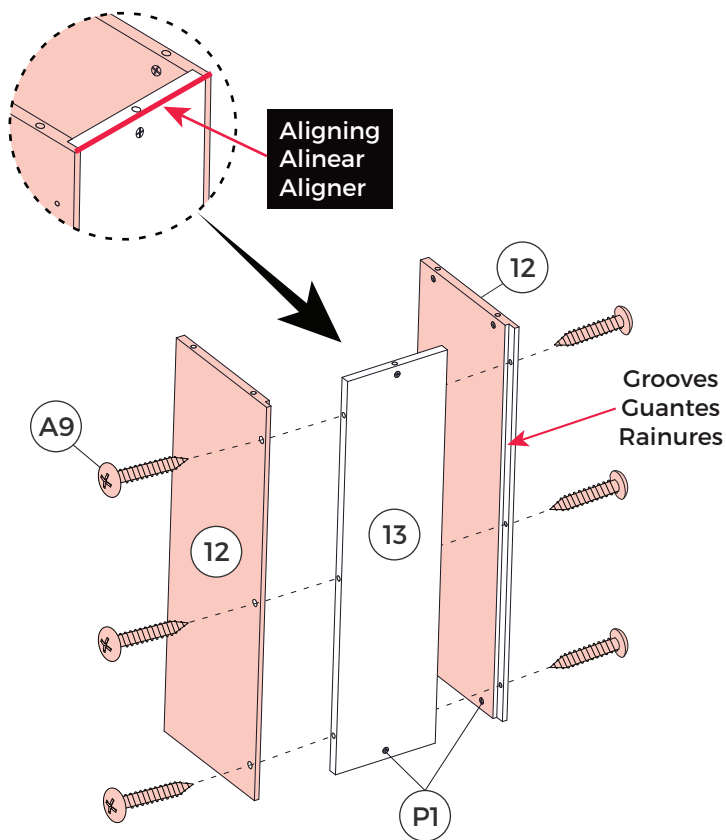
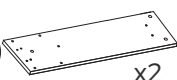







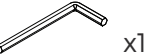
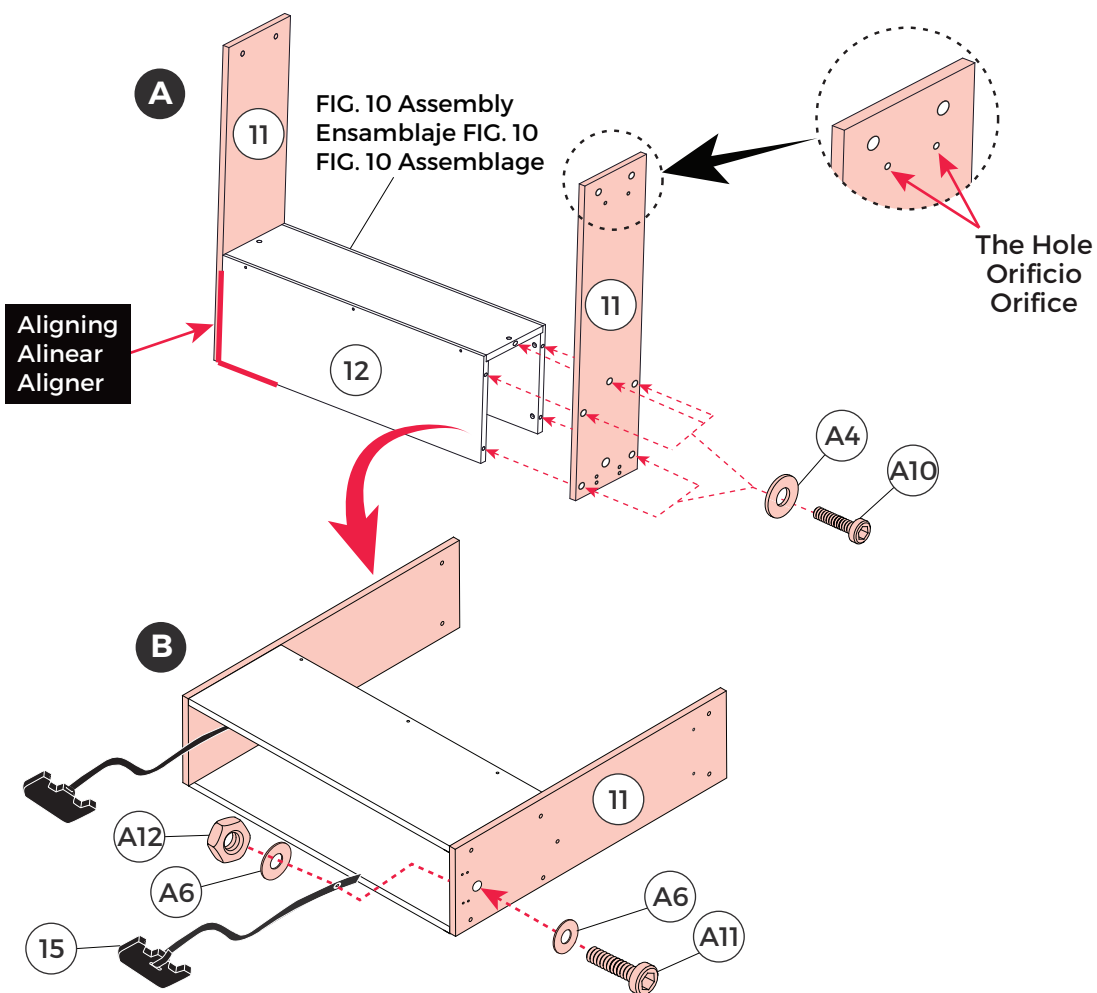

FIG. 11

- 11  x2
- 15  x2
- A4  x10
- A6  x4
- A10  x10
- A11  x2
- A12  x2
- A17  x1
- A18  x1



ASSEMBLY

MONTAJE

ASSEMBLAGE

FIG. 12

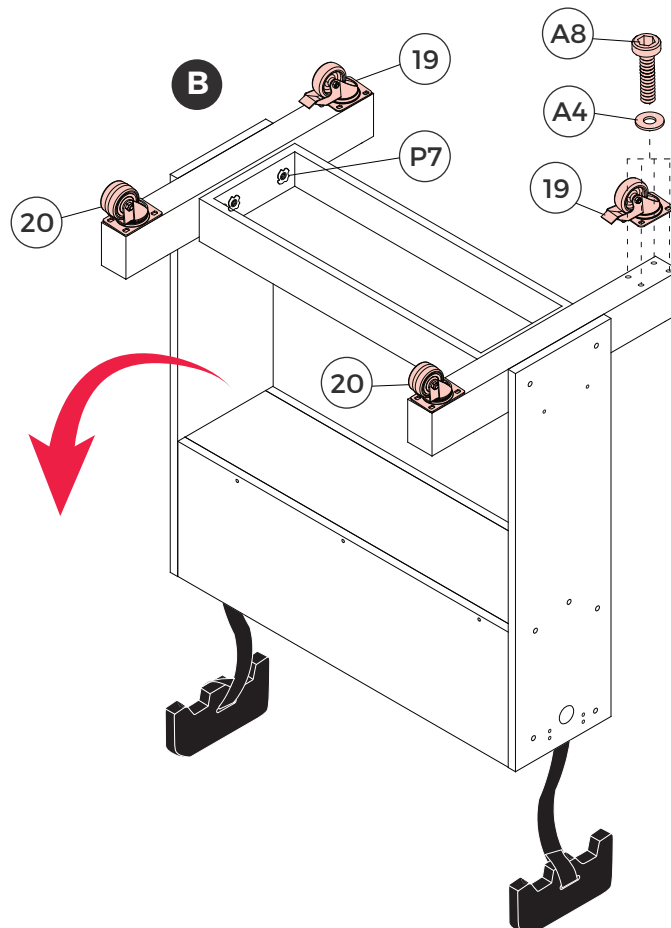
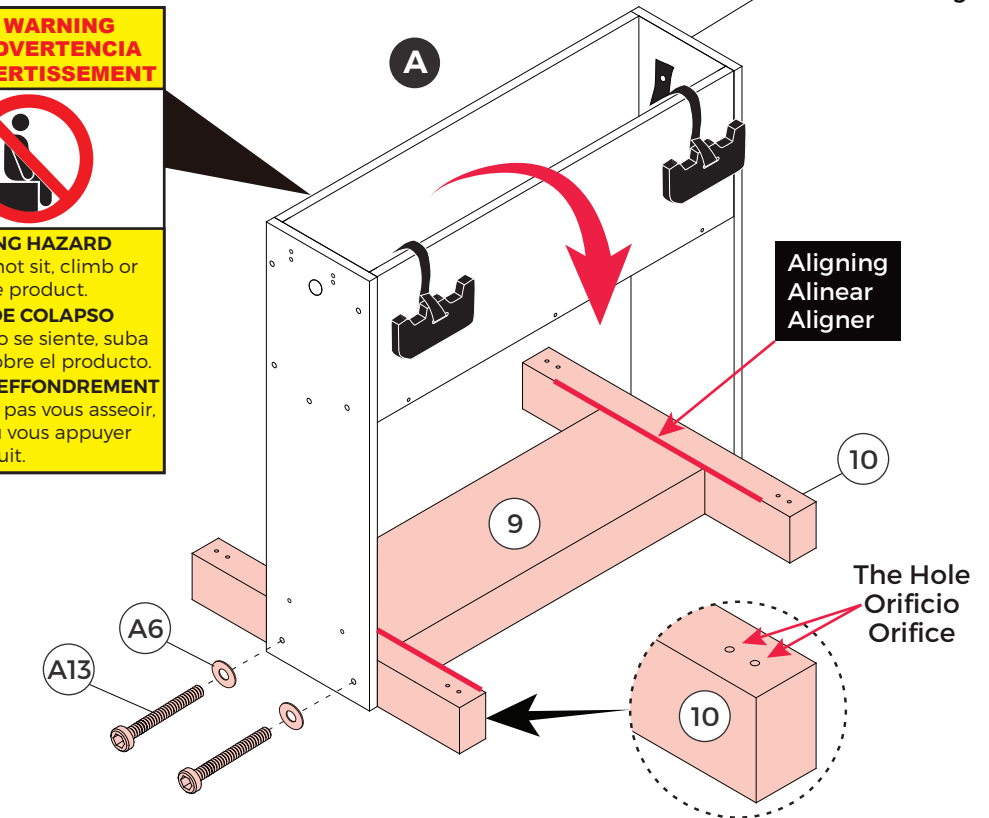
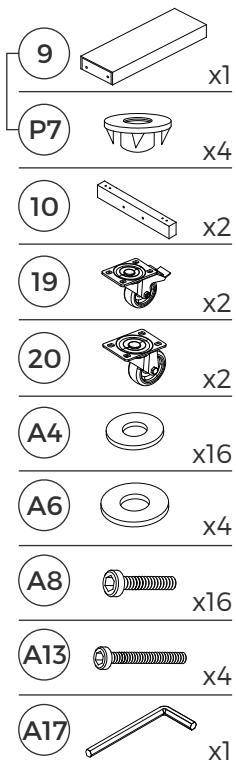





ASSEMBLY

MONTAJE

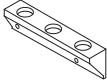
ASSEMBLAGE

FIG. 13

- 16**  x2
- 17**  x4
- 18**  x4
- A14**  x12
- A15**  x8

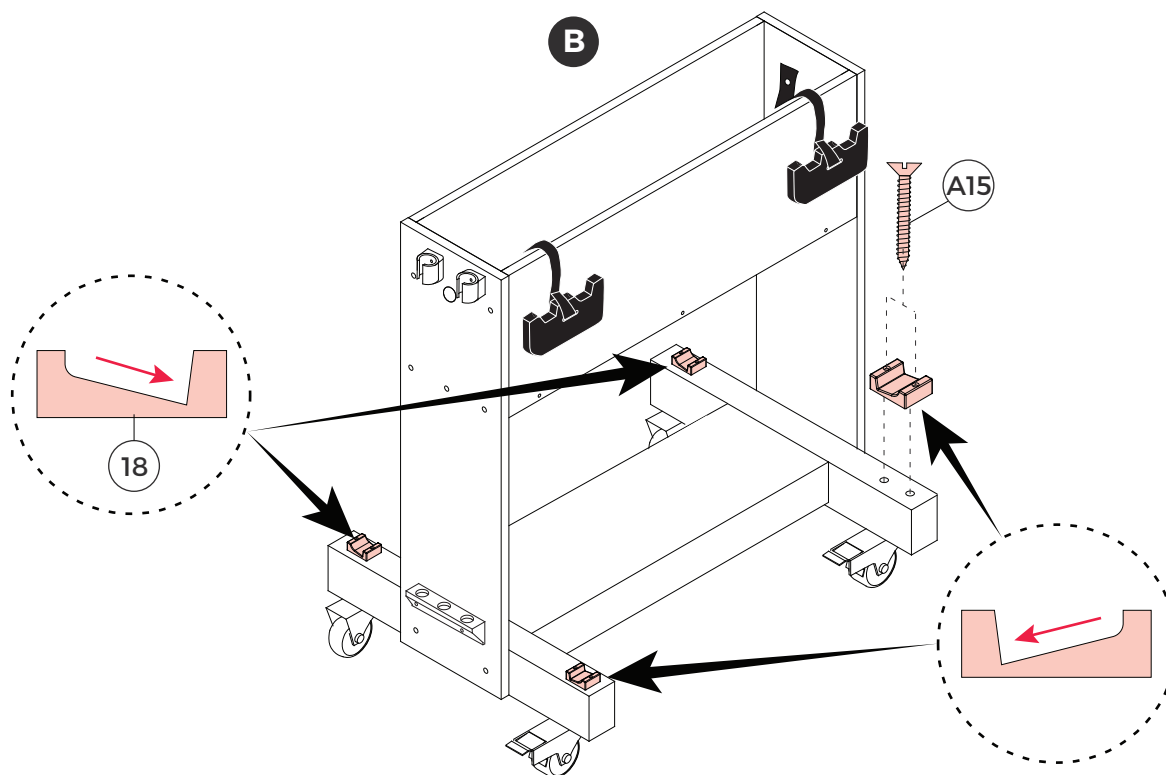
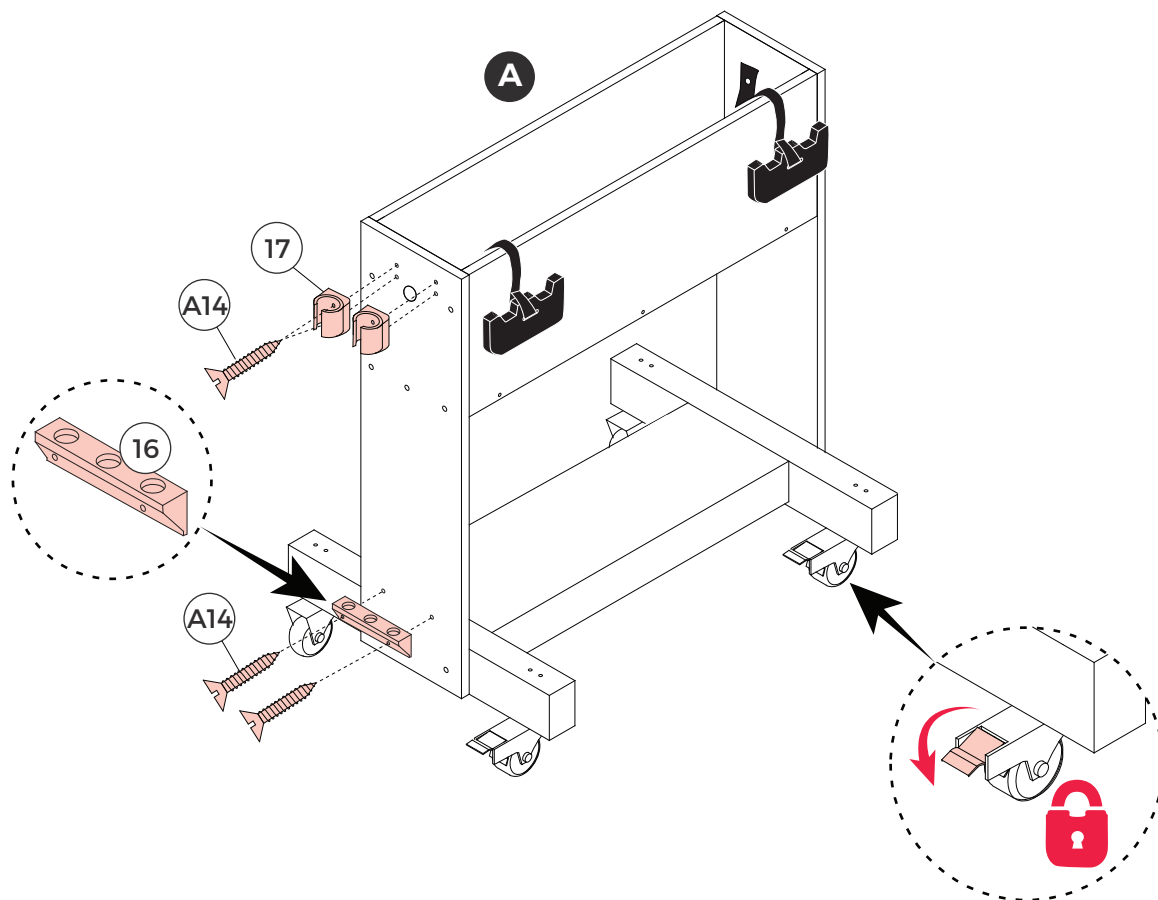

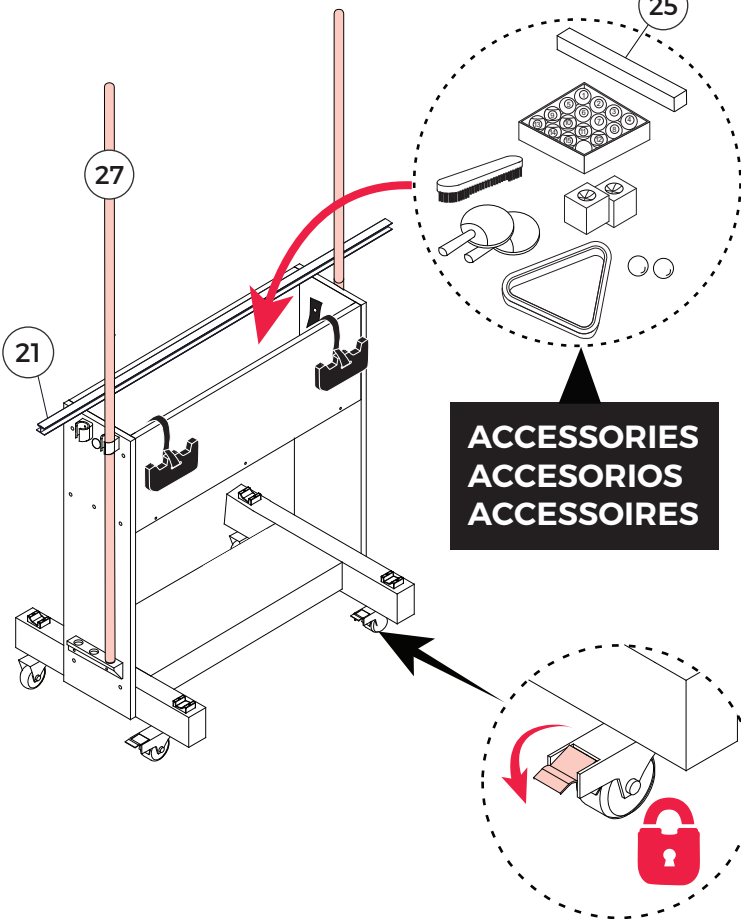
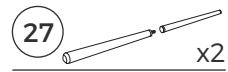
STEP 1
PASO 1
ÉTAPE 1STEP 2
PASO 2
ÉTAPE 2

ACCESSORIES
ACCESORIOS
ACCESSOIRES

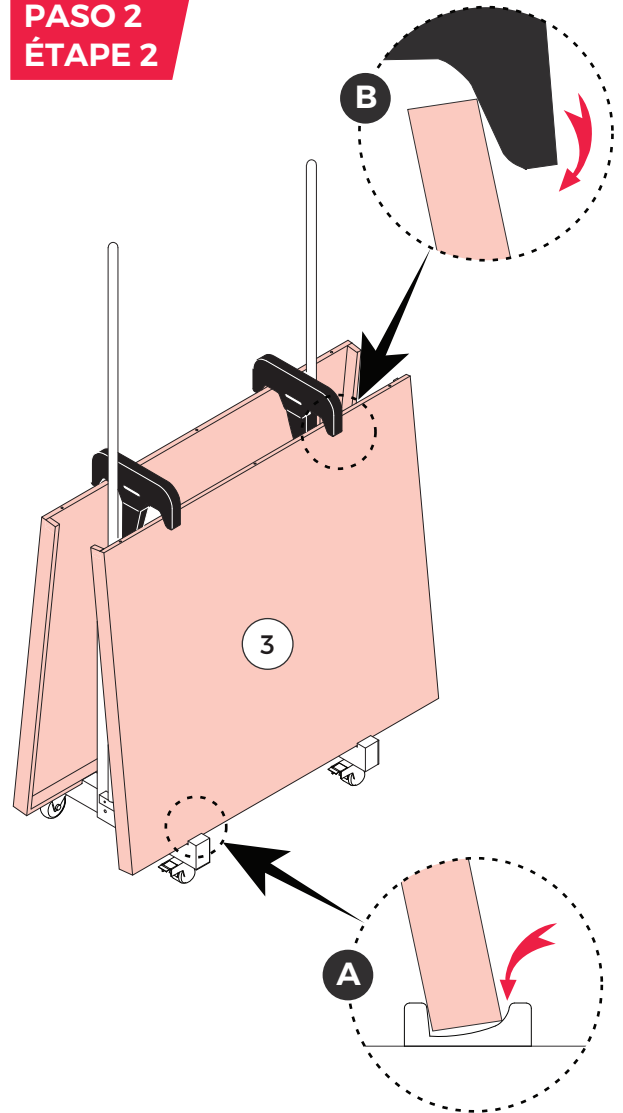

⚠ WARNING

When the table top is in the storage position, always keep the upper and lower snaps in place to prevent the sides from falling.

⚠ ADVERTENCIA

Cuando el tablero de la mesa esté en su posición de almacenamiento, siempre mantenga los broches superior e inferior en su lugar para evitar que los lados se caigan.

⚠ ATTENTION

Lorsque le dessus de table est en position de rangement, maintenez le verrou supérieur et inférieur en place pour empêcher les côtés de tomber.



