

Depending on different series, the cushions may vary .



HEY YOU, DO NOT TIGHTEN ALL THE BOLTS UNTIL THE COMPLETION OF THE ASSEMBLY.

*If the holes are not aligned properly during installation, please loosen the bolts and try again .

**Assembly
video**



For any missing hardware, damaged parts and other problems.
WELCOME to email us at: service@behousewell.com

Or call at 1-888-733-8169 Toll free

Between 9AM and 5PM Eastern time, Monday through Friday

***Don't fully tighten all the bolts till the very end!**

PRE-ASSEMBLY PREPARATION:

- A cordless drill is recommended for ease of assembly.
- Clear out the space for assembly and lay out all of the parts based on the Parts List, extra room will allow you to easily determine if all the pieces are present.
- Keep small parts and pieces away from children until fully assembled.

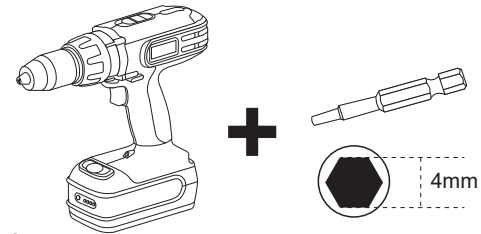

A1

Left
arm
1PC

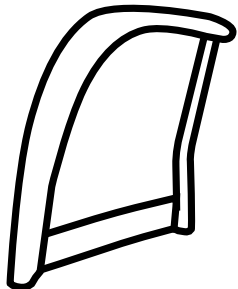

C

Seat
1PC

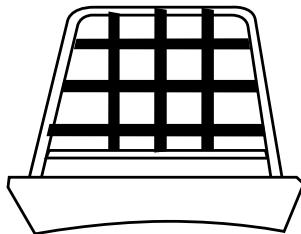

J

Seat
Cushion
1PCS



A2

Right
arm
1PC

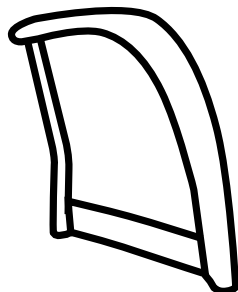

D

Base
1PC

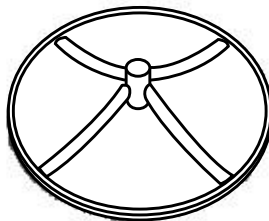

K

Back
Cushion
1PC

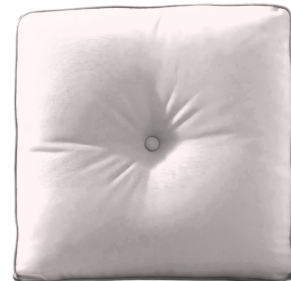

B



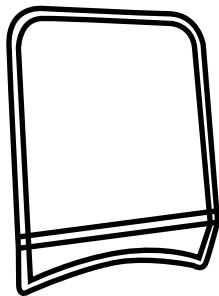

Back
1PC

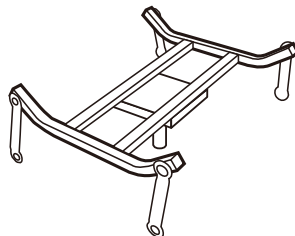

E

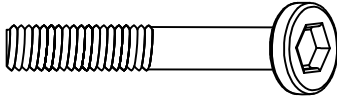
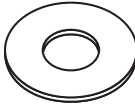
U-Shape
Fitting
1PC



F	Bolts		12
G	Washers		8
H	Nuts		4
I	Allen Wrench		1
L	Wrench		1

Step 1

Attach left arm A1 to back B with 2pcs bolts F and 2pcs washers G , using Allen wrench I .

Note : Don't fully tighten the bolts !

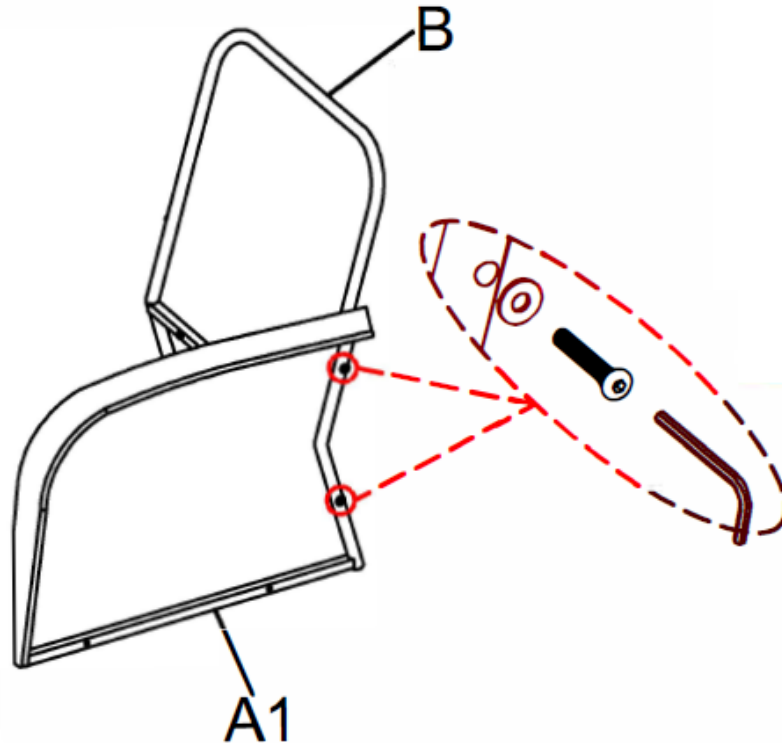
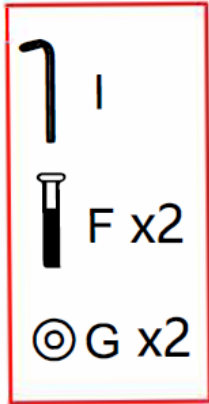

Step 2

Attach right arm A2 to back B with 2pcs bolts F and 2pcs washers G , using Allen wrench I .

Note : Don't fully tighten the bolts !

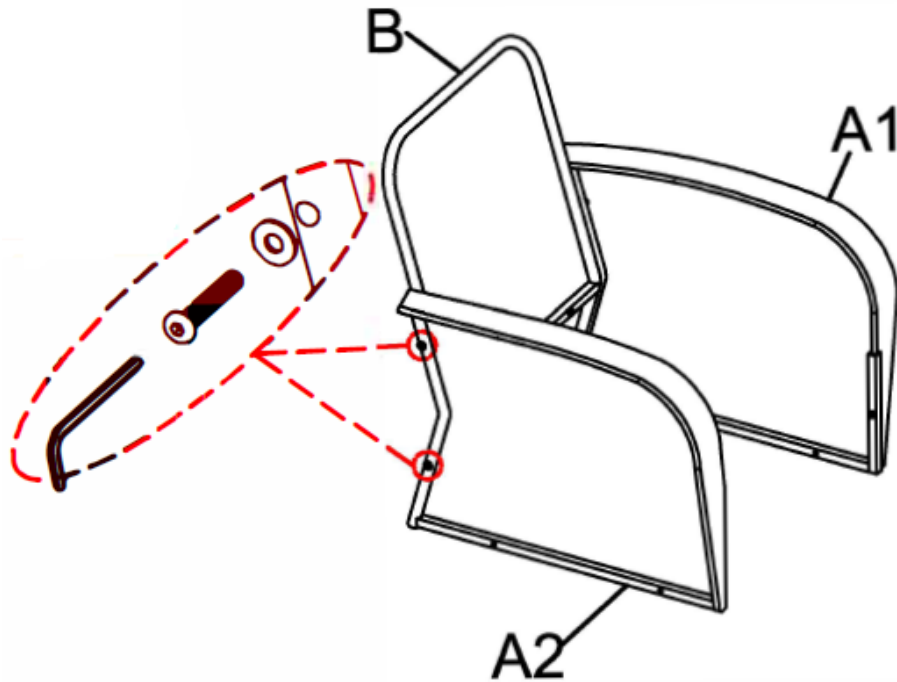
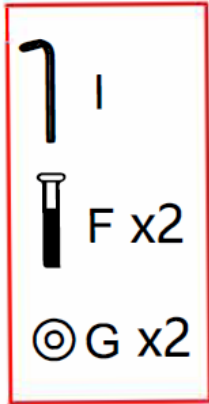

Step 3 Attach right arm A2 and left arm A1 to seat C with 2pcs bolts F and 2pcs washers G , using Allen wrench I .

Note : Don't fully tighten the bolts !

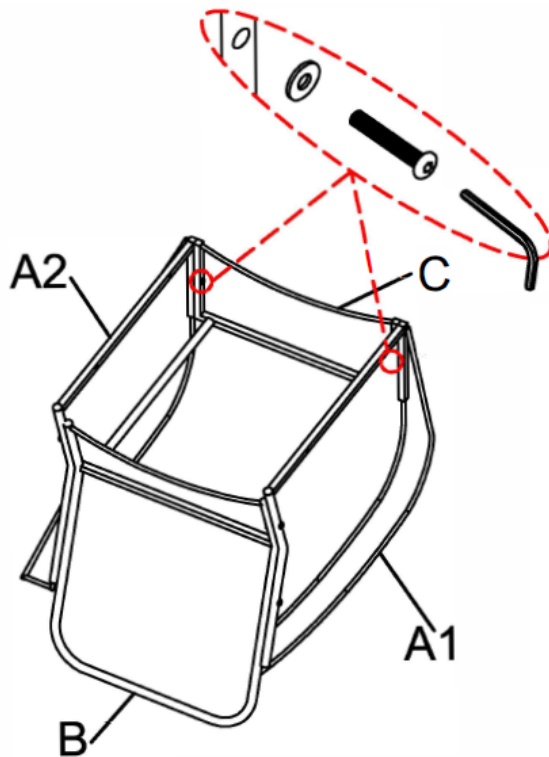
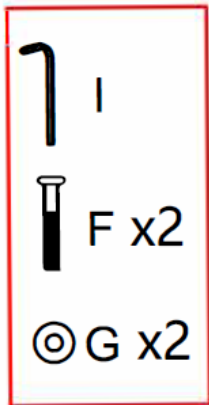

Step 4 Attach back B to seat C with 2pcs bolts F and 2pcs washers G , using Allen wrench I .

Note : Don't fully tighten the bolts !

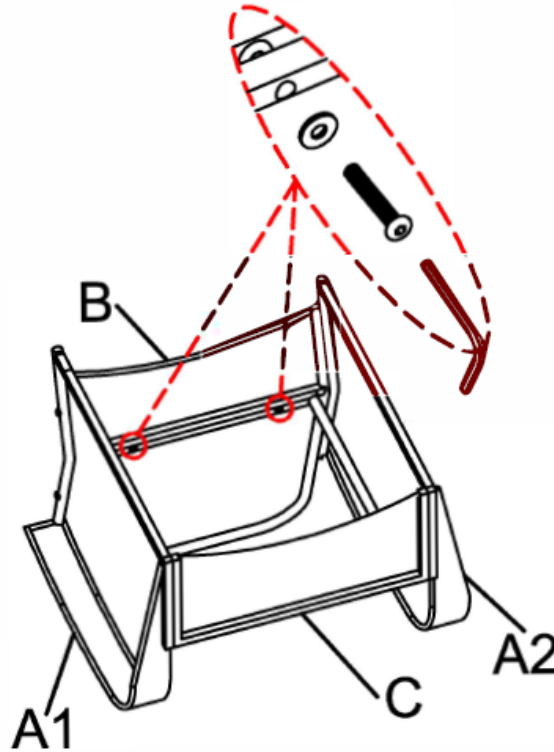
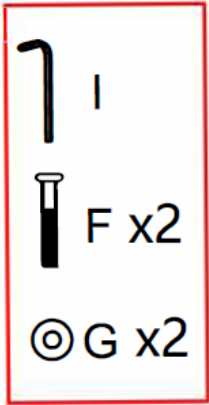

Step 5 Attach left arm A1 and right arm A2 to E with 4pcs bolts F and 4pcs nuts H , using Allen wrench I .

Note : Fully tighten all the bolts !

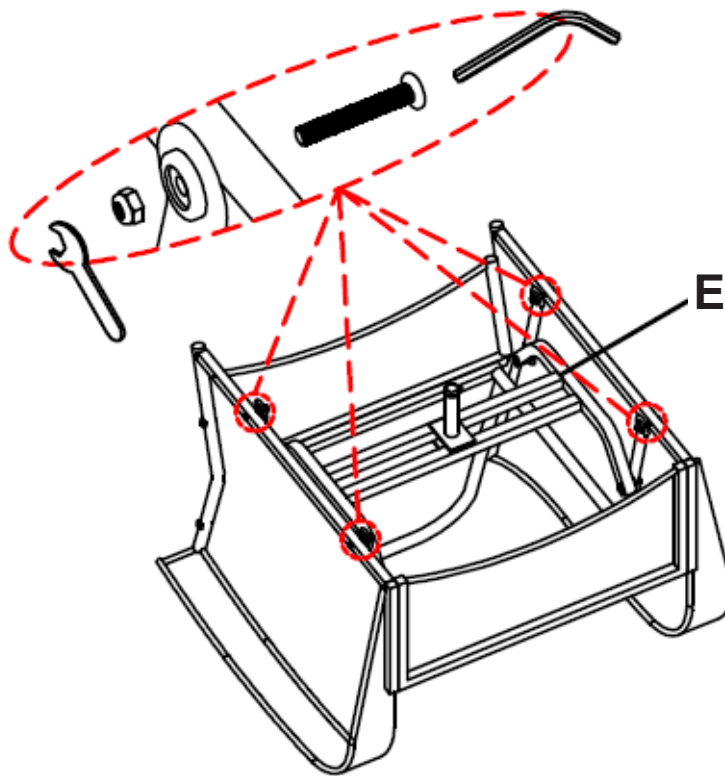
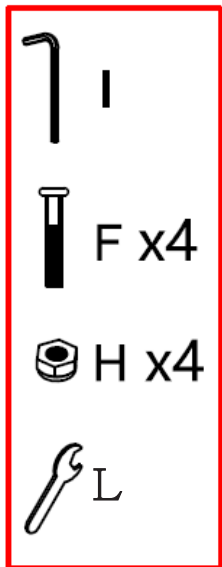

Step 6 Insert chair base (D) into chair bracket(E), then rotate chair base (D) back and forth until it is fully inserted

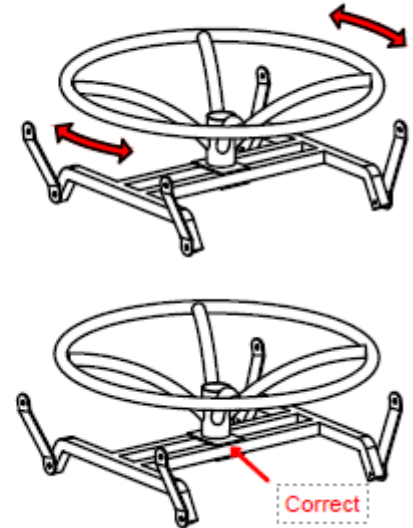
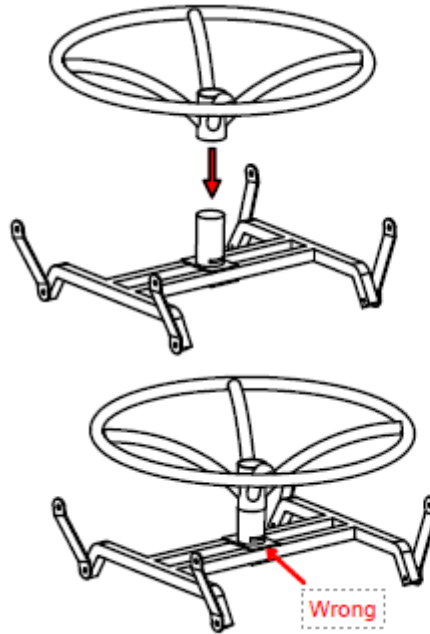
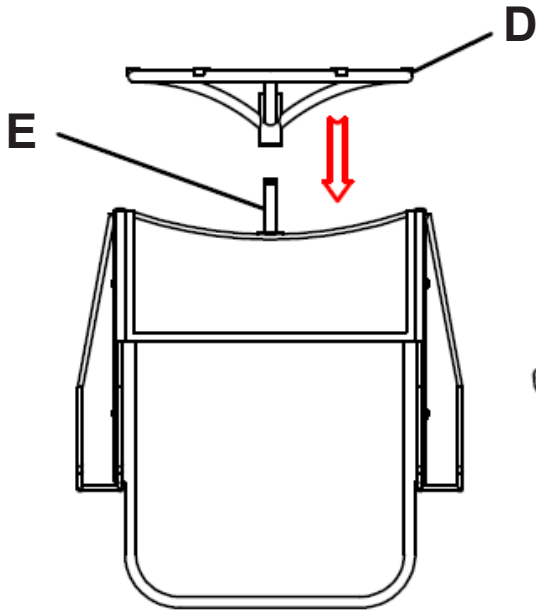

Step 6

Put seat cushion J and back cushion K

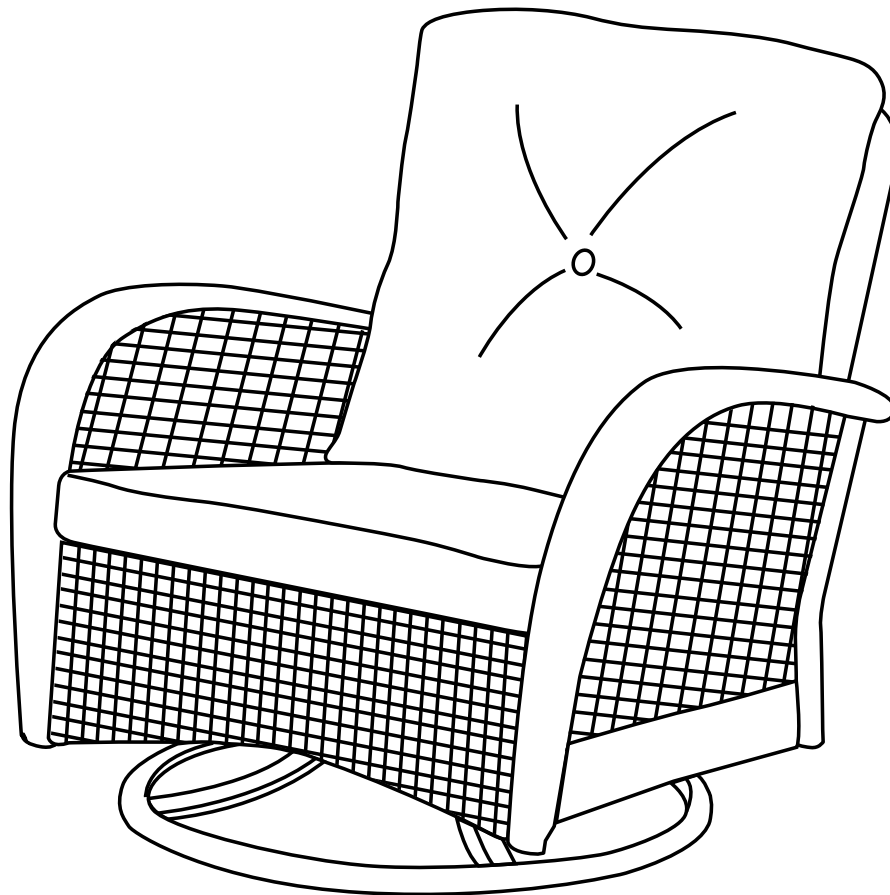

SPECIAL WARNING :

THIS CHAIR IS NOT A TOY. DON'T OVER-SWING THE CHAIR .OVER-SWING THE CHAIR MAYBE MAKE THE CAHIR TIP OVER AND RESULT IN INJURY. DO NOT STAND ON THE CHAIR . ANY IMPROPER USE OF THIS PRODUCT MAY RESULT IN INJURY .



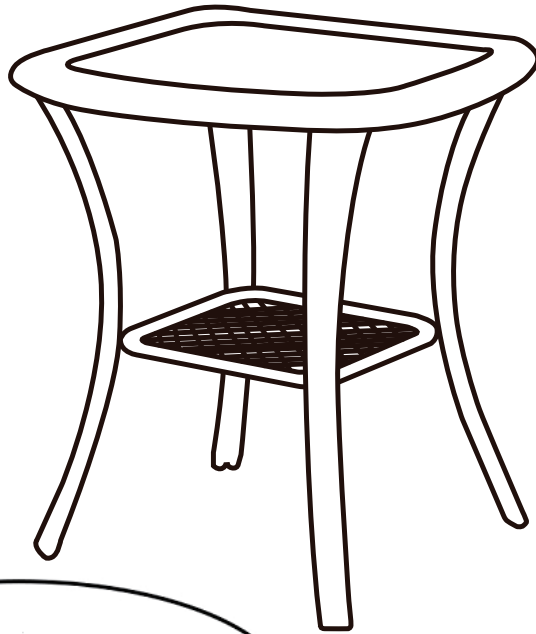





**Assembly
video**

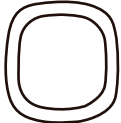

**HEY YOU, DO NOT TIGHTEN ALL THE
BOLTS UNTIL THE COMPLETION OF
THE ASSEMBLY.**

***If the holes are not aligned properly during installation,
please loosen the bolts and try again .**

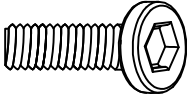
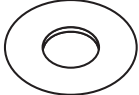
A	Table Top		1
B	Table Leg		4
C	Table Shelf		1

D	Bolts		12
E	Washers		12
F	Allen Wrench		1

(1) Note : Don't fully tighten the bolts !

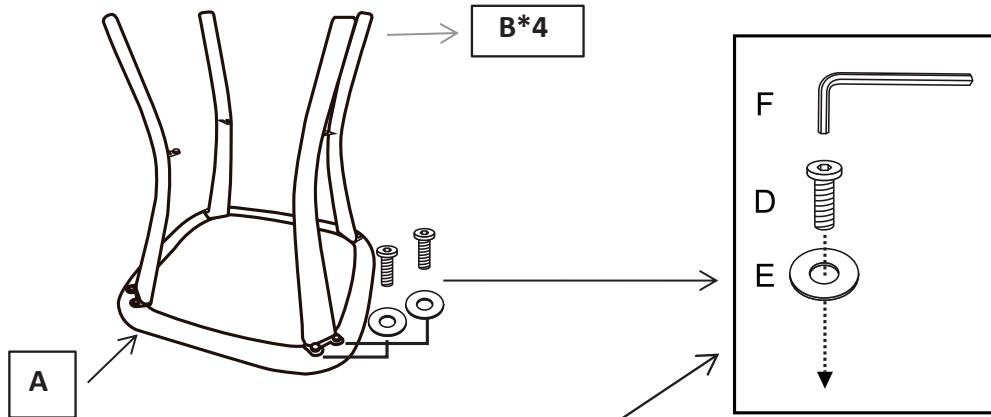

(2)

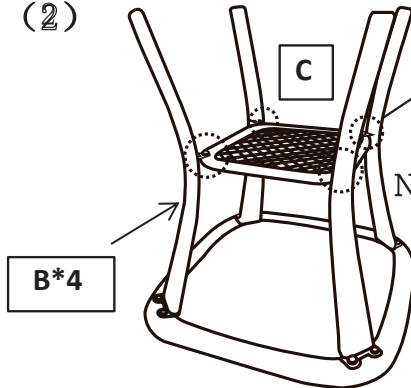

Note : Fully tighten all the bolts !

(3)

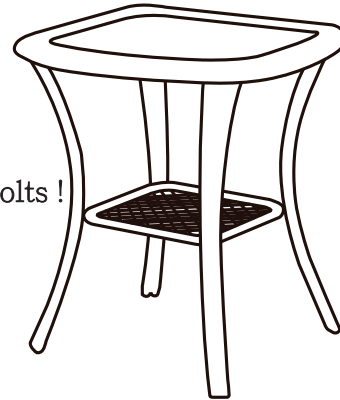

Q & A:

Q: Frame drilling holes not align?

A: If discrepancy less than 1/8 in., please loosen other relative bolts first, then adjust parts position and re-tight all bolts.

if discrepancy more than 1/4 in., it should be parts deformation during violent transportation, please contact us for parts replacement.

Q: Why cushion shrink packing and how to help it rebound faster?

A: We shrink packing cushion is to improve product value to cost, because it can save transport cost a lot. We filled it with more and high-quality filling than normal cushion to make sure it can be fully rebound. Following up this video(<https://youtu.be/IZAIHQ9Ial>)method to speed up rebounding.

Q: Coffee table legs un-even?

A: Loosen bolts, then press table downwards, then tighten bolts again. If it can not solve problem, please contact us for parts replacement.

Q: Wicker colors different on parts?

A: We make wicker stripes to fit for nature environment, colors may various circularly. So when those wicker stripes hand-woven on product randomly, it may looks different on parts.

Q: Why some swivel plate not work well?

A: Swivel plate may need a running-in period like 10~20 cycles. If it still not swivel well, please contact us for swivel plate replacement.

Q: Bolts are not long enough for assembly sometimes?

A: Sometimes gaps maybe larger than the bolts to reach out when assembly, please contact us for longer bolts. After all, those parts are woven by hand-made. But after it assembled and all bolts tightened, the gaps will be disappeared, because wicker parts are flexible surface.

Q: Parts received damaged?

A: Although we had already did our best to pack products well, there are also unpredictable transport damages accident happened from time to time. When it happens, please contact our after-sales email, state the order number/which shopping platform it comes from/one of the parcel tracking number, and provide the relevant pictures of the problem, we will immediately provide you with a suitable replacement parcel.

Q:Received item but missing hardware or parts

A:Please contact our after-sales email, state the order number/which shopping platform it comes from/one of the parcel tracking number, and provide the relevant pictures of the problem, we will immediately provide you with a suitable replacement parcel.