









ASSEMBLY INSTRUCTIONS

PARTS LIST-BOX 1/2

NO	SKETCH	DESCRIPTION	QTY
1		Bolt(ϕ 5/16" * 32mm)	4PCS
2		Bolt(ϕ 1/4" * 63mm)	12PCS
3		Lock washer (5/16")	16PCS
4		Flat washer (5/16" * ϕ 19mm)	16PCS
5		Allen key(4mm)	1PC
C		Base	4PCS

PARTS LIST-BOX 2/2

NO	SKETCH	DESCRIPTION	QTY
A		Table Top	1PC
B		Connecting panel	1PC

Step 1 Remove the Connecting Panel (B) from the Table Top (A) and set it aside. Keep any loose hardware inside the panel for later use.

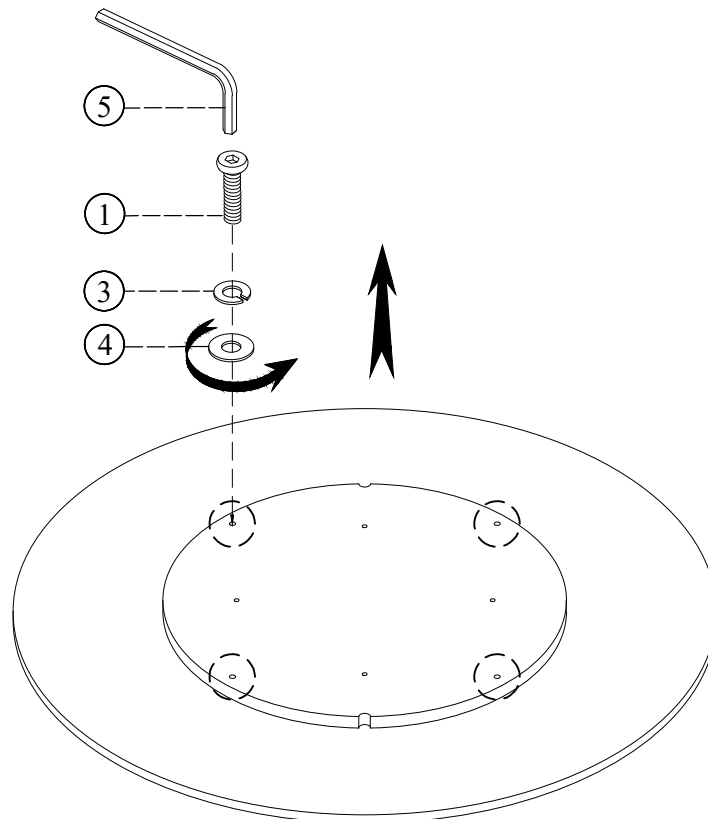

ASSEMBLY INSTRUCTIONS

Step 2 Attach each Base (C) using: Bolt (2) Lock Washer(3) Flat Washer(4)
Secure with the Allen Key (5).
(Do not fully tighten the bolts until all bases are assembled.)

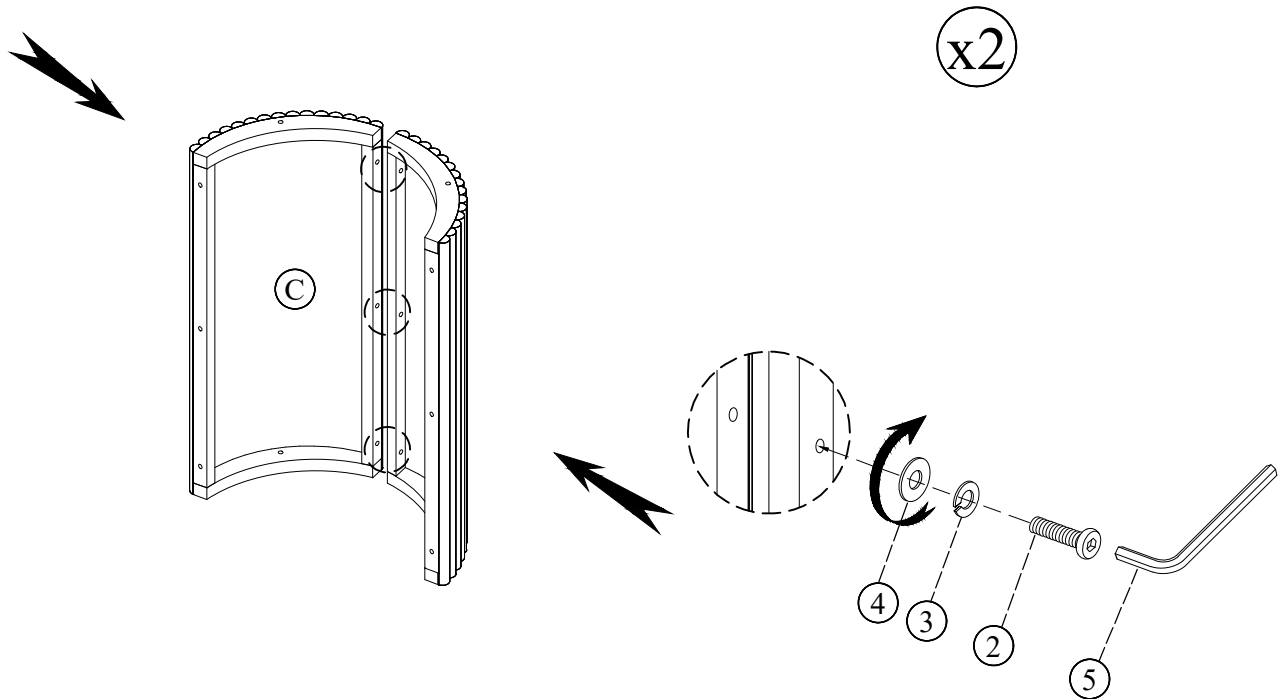

Step 3 Join the two assembled base pairs from Step 2 together, again using:
Bolt (2) LockWasher (3) FlatWasher (4)
Use the Allen Key (5) to secure.
Make any small adjustments so the bases sit flush and the table is level.

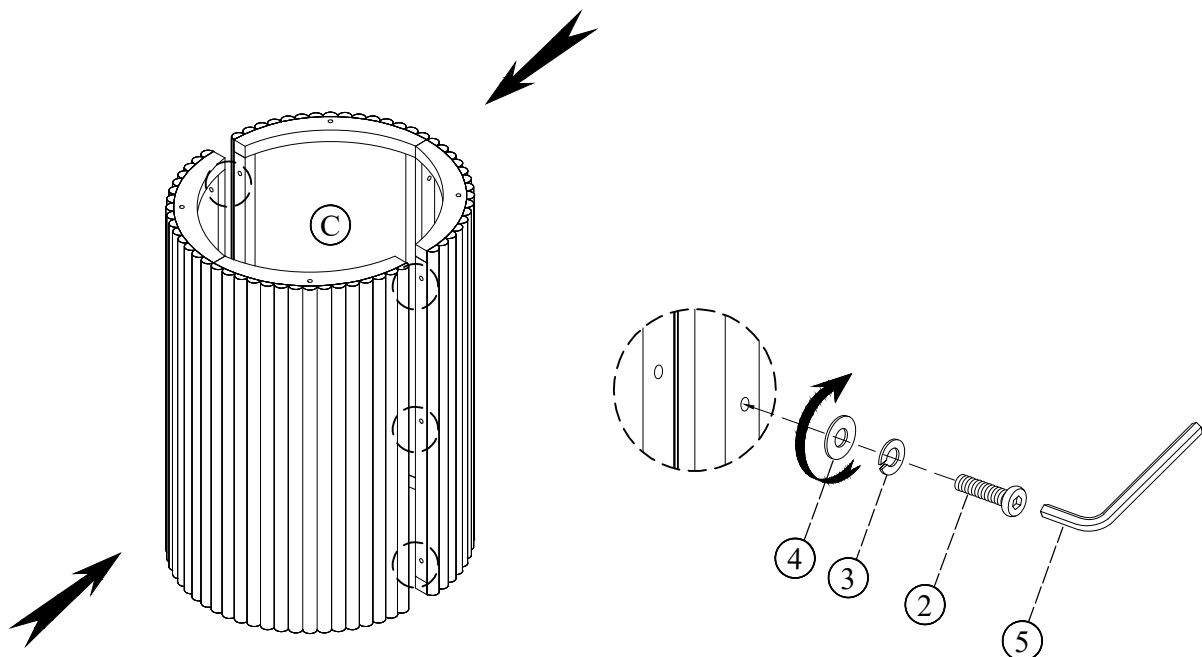

ASSEMBLY INSTRUCTIONS

Step 4 Place the connected base flat on the soft pad as shown in the picture, and you will be able to tighten all the screws more easily.

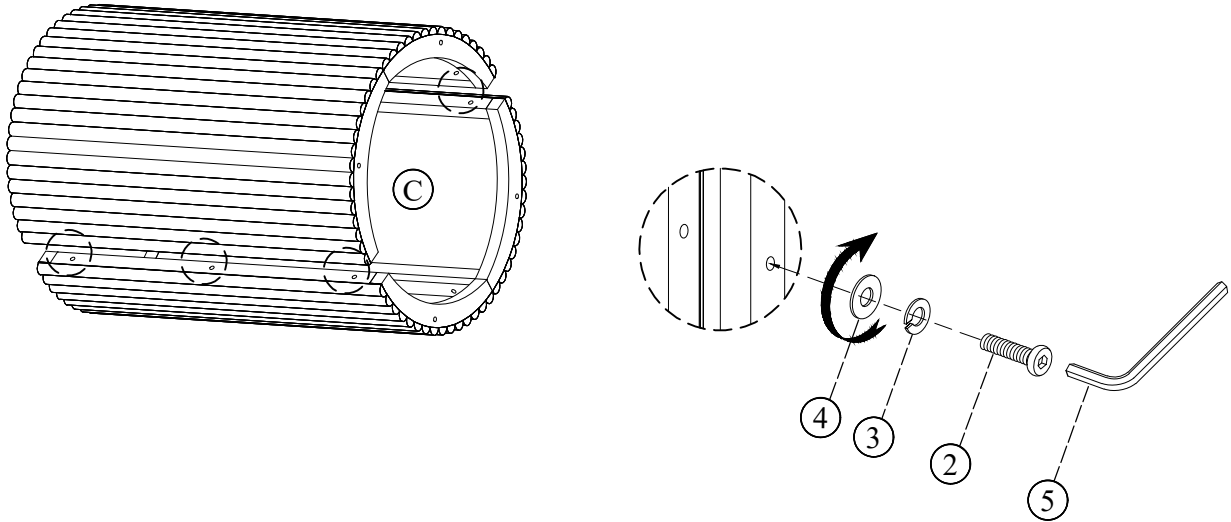

Step 5 Place the Connecting Panel (B) onto the four assembled Bases (C), aligning the holes. Secure with Bolt (1), Lock Washer (3), and Flat Washer (4). Tighten firmly using the Allen Key (5).

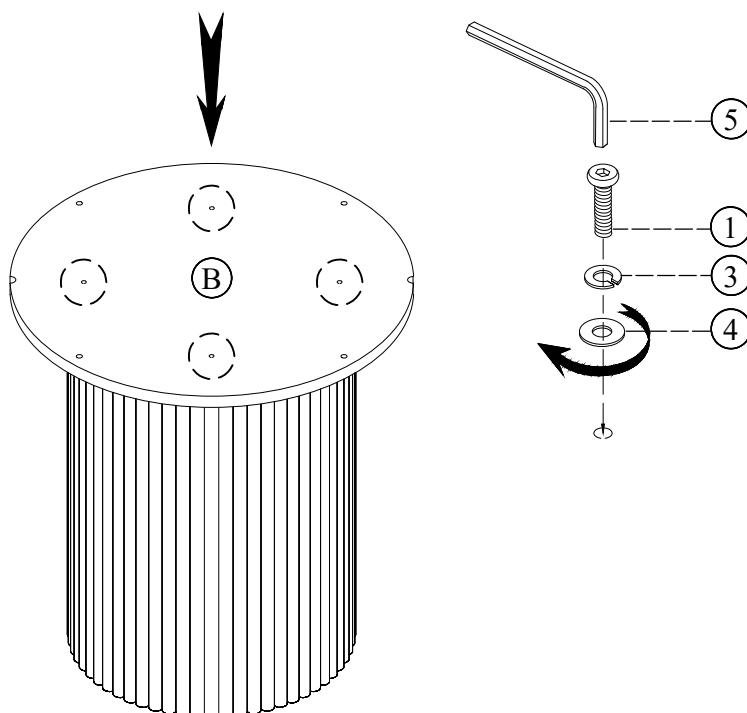

ASSEMBLY INSTRUCTIONS

Step 6 Place the Table Top (A) on the pre-assembled base structure (including the Connecting Panel (B)). Align the outer notches with the holes, and secure using Bolt (1), Lock Washer (3), and Flat Washer (4). Tighten all bolts firmly with the Allen Key (5).

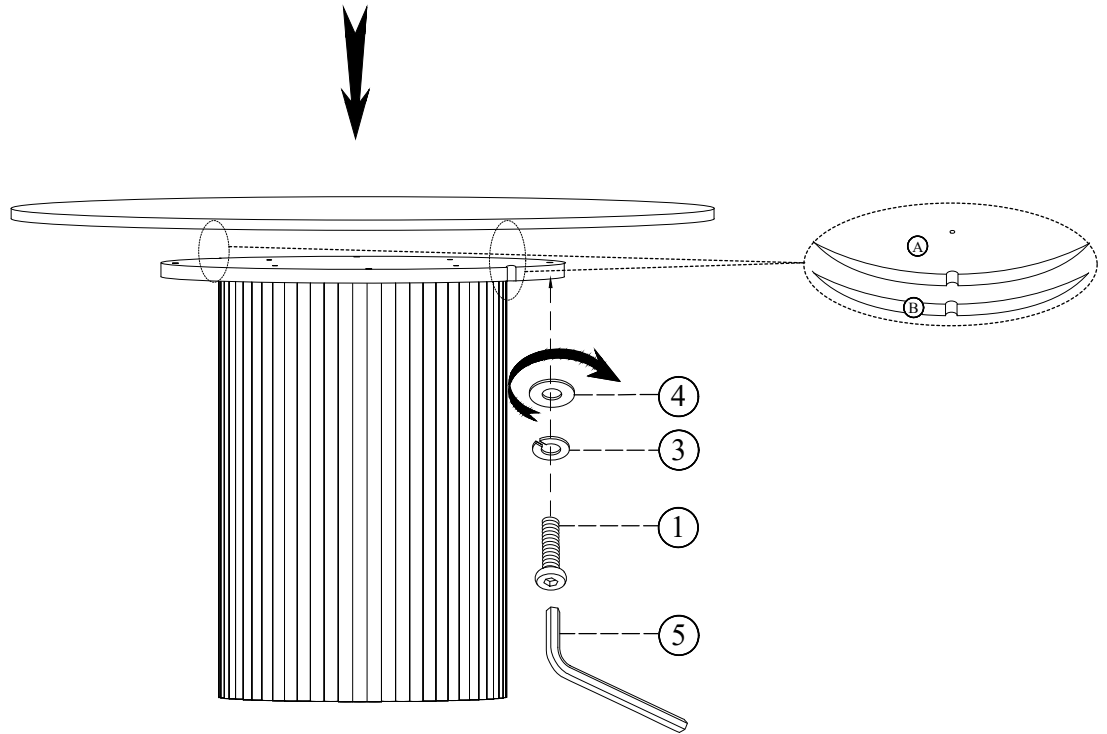

Step 7

