











ASSEMBLY INSTRUCTIONS

Thank you for purchasing this quality product. Be sure to check all packing material care fully for small parts, which may have come loose inside the carton during shipment. Identify and count all parts and compare with the **HARDWARE LIST** below.

HARDWARE / PARTS LOCATION

D1623 DC > Step 1 & 2 hardware > Inside red pack with red tape > Placed underneath seat frame with cushion > Leg > Inside labeled inner carton > Placed underneath seat frame with cushion > Stretcher > Placed aboved seat frame with cushion > Seat frame with cushion > Placed in the bottom.

NO.	DESCRIPTION	SKETCH	QTY
A	Chair Back		1PC
B	Seat Frame With Cushion		1PC
C	Left Front Leg		1PC
D	Right Front Leg		1PC
E	Stretcher		2PCS

NO.		HARDWARE LIST	QTY
1		Bolt (Ø1/4"x70mm)	8Pcs
2		Bolt (Ø1/4"x40mm)	2Pcs
3		Spring Washer (Ø1/4"x11x2mm)	10Pcs
4		Flat Washer (Ø1/4"x19x2mm)	10Pcs
5		Allen Wrench 4mm	1Pc
6		Wood Screw (#4x38mm)	4Pcs

STEP 1

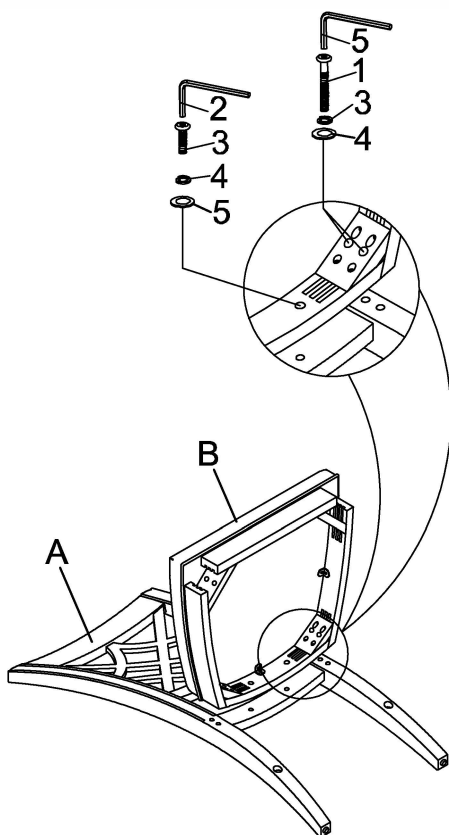

STEP 2

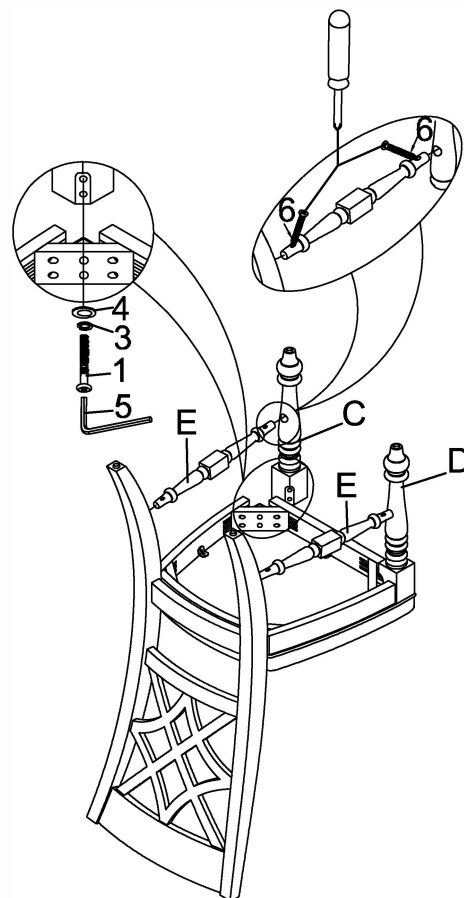

COMPLETED

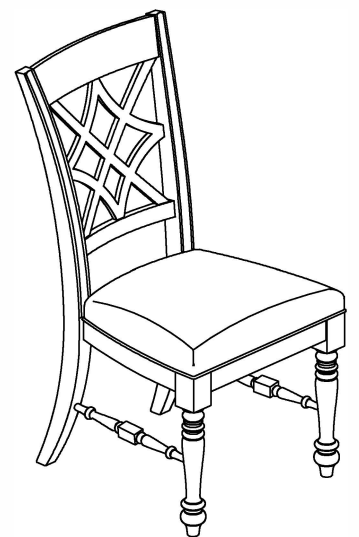

Note: Please **DO NOT** fully tighten all screws and bolts until the entire item is completely assembled