

ASSEMBLY INSTRUCTIONS COASTER FINE FURNITURE



Fine Furniture for every stage of life

800108
COMPUTER DESK

ITEM:800108

ASSEMBLY INSTRUCTIONS

ASSEMBLY TIPS:

1. Remove hardware from box and sort by size.
2. Please check to see that all hardware and parts are present prior to start of assembly.
3. Please follow attached instructions in the same sequence as numbered to assure fast & easy assembly.





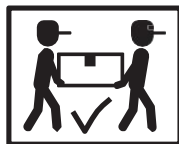



- WARNING!**
1. Don't attempt to repair or modify parts that are broken or defective. Please contact the store immediately.
 2. This product is for home use only and not intended for commercial establishments.

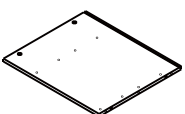
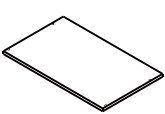
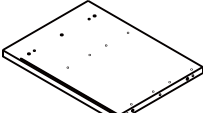
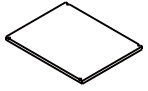
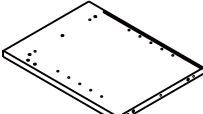
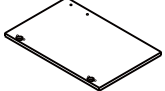
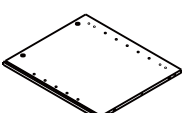
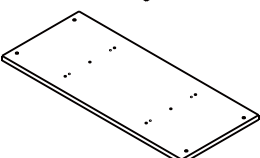
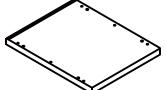
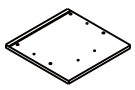
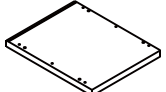

ASSEMBLY TIME

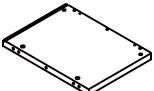
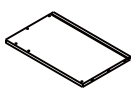
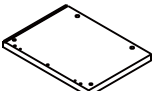
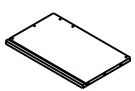
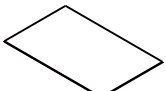
70 MINUTES

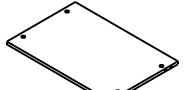
PARTS IDENTIFICATION

A	LEFT SIDE PANEL		1 PC	K	KEYBOARD SHELF		1 PC
B	LEFT DIVIDER PANEL		1 PC	L	ADJUSTABLE SHELF		1 PC
C	RIGHT DIVIDER PANEL		1 PC	M	DOOR		1 PC
D	RIGHT SIDE PANEL		1 PC	N	LARGE TOP PANEL		1 PC
E	LEFT BOTTOM PANEL		1 PC	O	LARGE DRAWER FRONT PANEL		1 PC
F	RIGHT BOTTOM PANEL		1 PC	P	LARGE DRAWER BACK PANEL		1 PC
G	SMALL LEFT TOP PANEL		1 PC	Q	LARGE LEFT DRAWER SIDE PANEL		1 PC
H	SMALL RIGHT TOP PANEL		1 PC	R	LARGE RIGHT DRAWER SIDE PANEL		1 PC
I	SMALL BACK PANEL		2PCS	S	SMALL DRAWER FRONT PANEL		1 PC
J	LARGE BACK PANEL		1 PC	T	SMALL DRAWER BACK PANEL		1 PC

NOTE:

Phillips head screw driver is required in the assembly process; however, manufacturer does not provide this item.

ITEM:800108

U SMALL LEFT
DRAWER SIDE
PANEL 1 PC

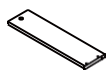

V SMALL RIGHT
DRAWER SIDE
PANEL 1 PC

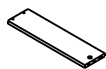

W DRAWER
BOTTOM PANEL 2 PCS

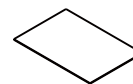

Z

HARDWARE IDENTIFICATION

NO	DESCRIPTION	FIGURE	Q'TY	NO	DESCRIPTION	FIGURE	Q'TY
1	GLUE 40g		1 PC	12	SCREW FOR EURO SLIDE (Ø 3x12mm SR)		28 PCS
2	WOODEN DOWEL Ø 8x30mm		38 PCS	13	HANDLE L=120mm		3 PCS
3	CAM BOLT (Ø 7x35.5mm SR)		20 PCS	14	HANDLE BOLT (Ø 4x28mm SR)		6 PCS
4	CAM LOCK (Ø 15x12mm SR)		20 PCS	15	FOOT 50x50x18mm		8 PCS
5	BOLT (Ø 9.5x55mm) FOR BOTTOM PANEL		12 PCS	16	LONG SCREW (Ø 5x23mm BLK)		16 PCS
6	SCREW FOR DRAWER (Ø 4.3x35mm SR)		8 PCS	17	HINGE (Ø 26 SR)		2 PCS
7	DOOR CATCH		1 PC	18	SCREW FOR HINGE (Ø 4x15mm SR)		8 PCS
8	PIN (Ø 4.9x8mm SR)		4 PCS	19	IRON BAR L=80mm		4 PCS
9	RAIL (L = 350mm SR)		1 SET	20	BOLT FOR IRON BAR (M6x42mm SR)		4 PCS
10	SCREW FOR RAIL (Ø 3.5x12mm SR)		10 PCS	21	IRON BAR Ø 9.5x311mm SR		2 PCS
11	EURO SLIDE (L = 450mm WHT)		2 SET	22	STICKER Ø 20mm		4 PCS

Z9,Z10,Z11,Z13,Z14,Z15,Z17,Z19,Z21 not included in blister packaging.

NOTE:

Phillips head screw driver is required in the assembly process; however, manufacturer does not provide this item.

ITEM: 800108

STEP 1

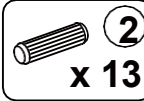
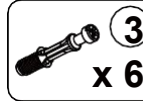
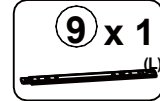
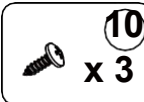
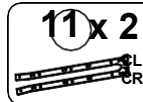
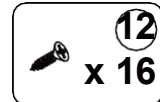
-  2 x 13
-  3 x 6
-  9 x 1
-  10 x 3
-  11 x 2 (L/CR)
-  12 x 16

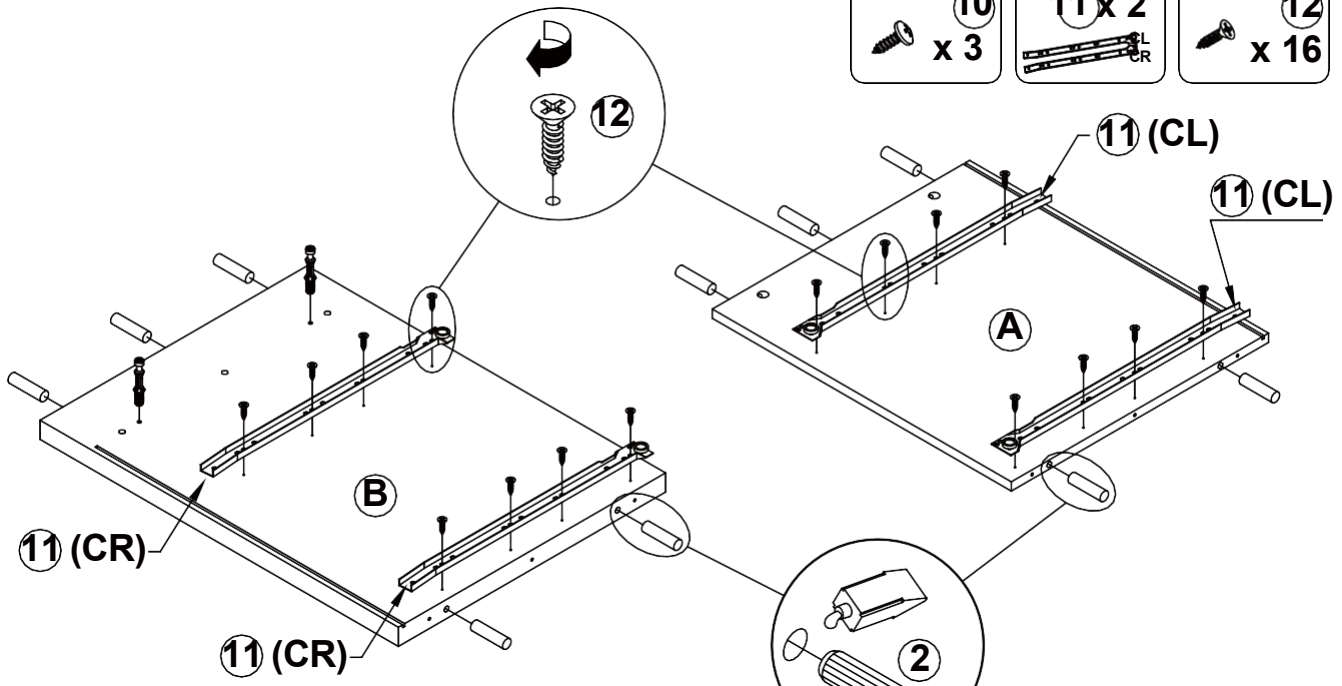

the reverse side

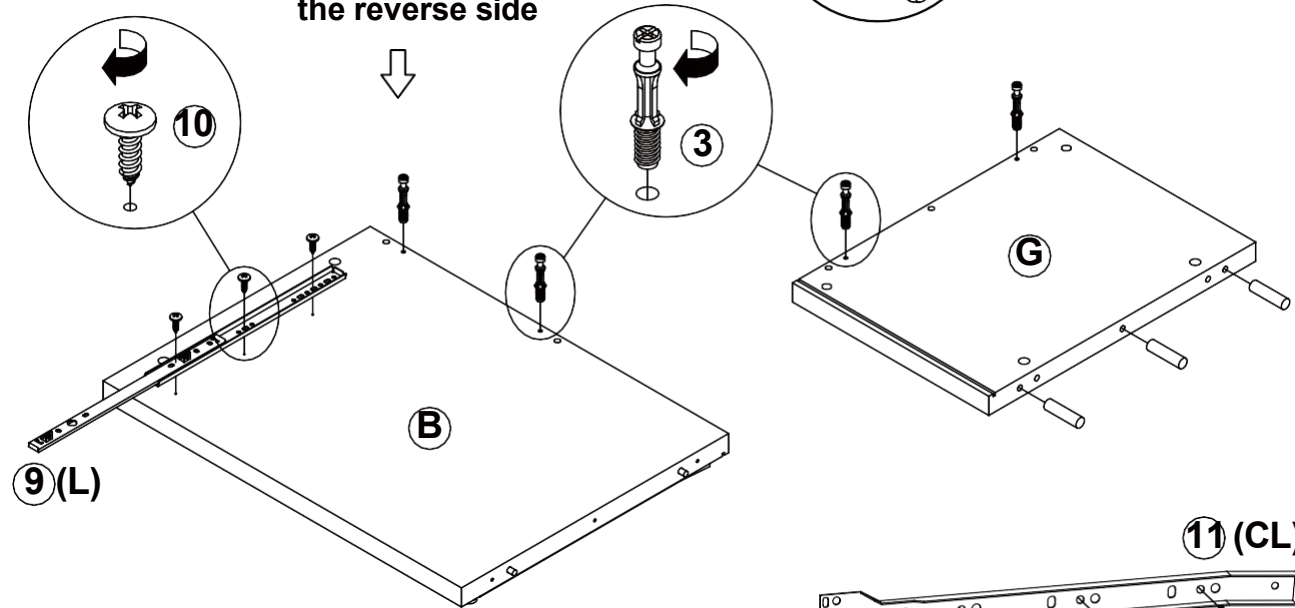

INCORRECT CORRECT

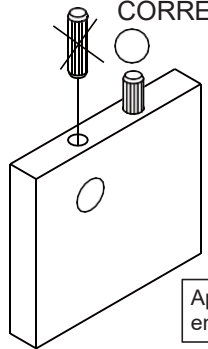

Apply glue on all wooden dowels to ensure integrity of the structure.

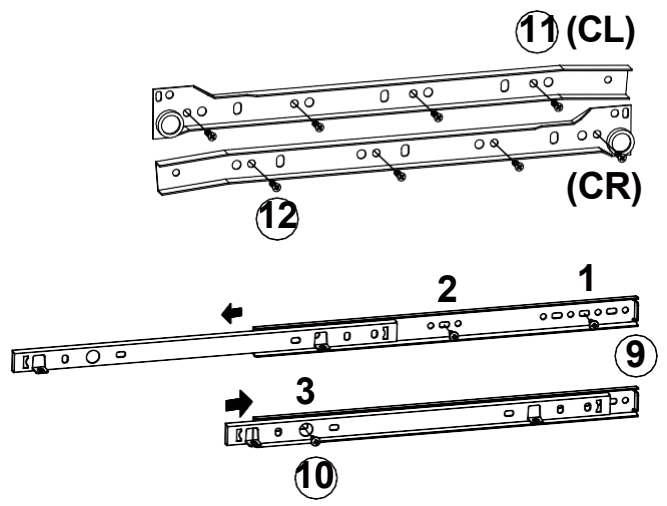

ITEM:800108

STEP 2

Apply glue on all wooden dowels to ensure integrity of the structure.

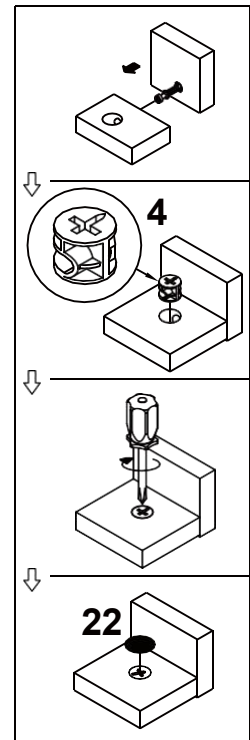
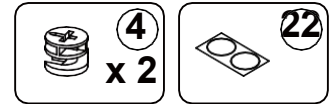
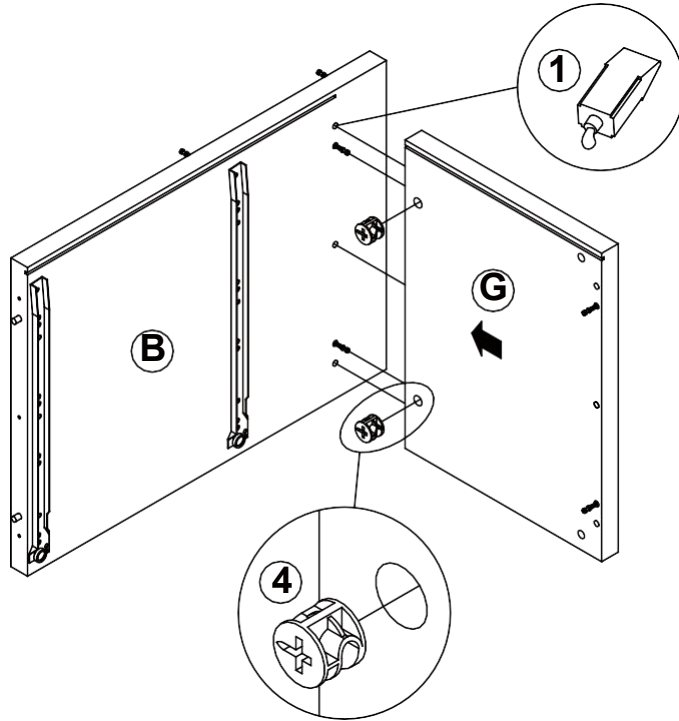

STEP 3

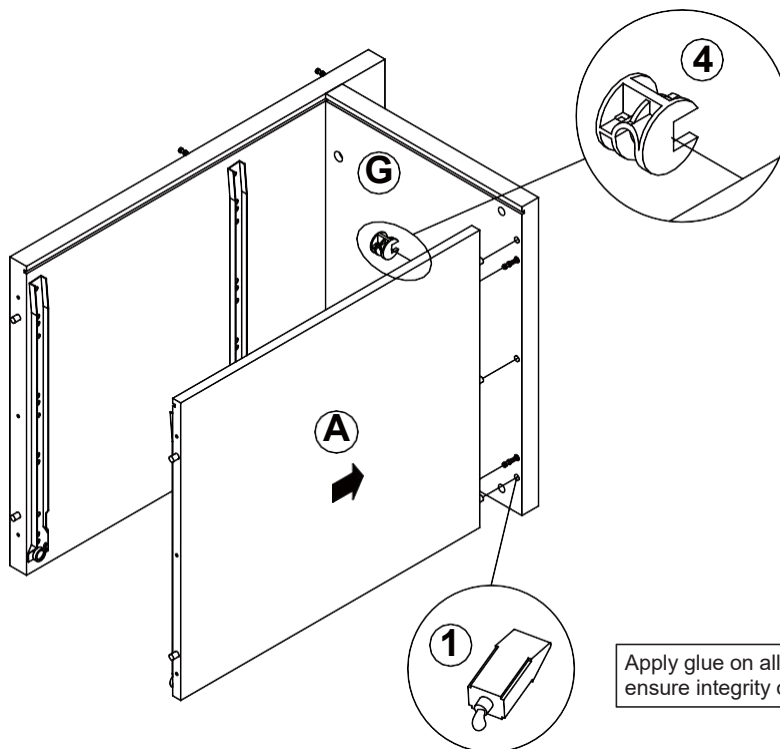

Apply glue on all wooden dowels to ensure integrity of the structure.

ITEM: **800108**

STEP 4

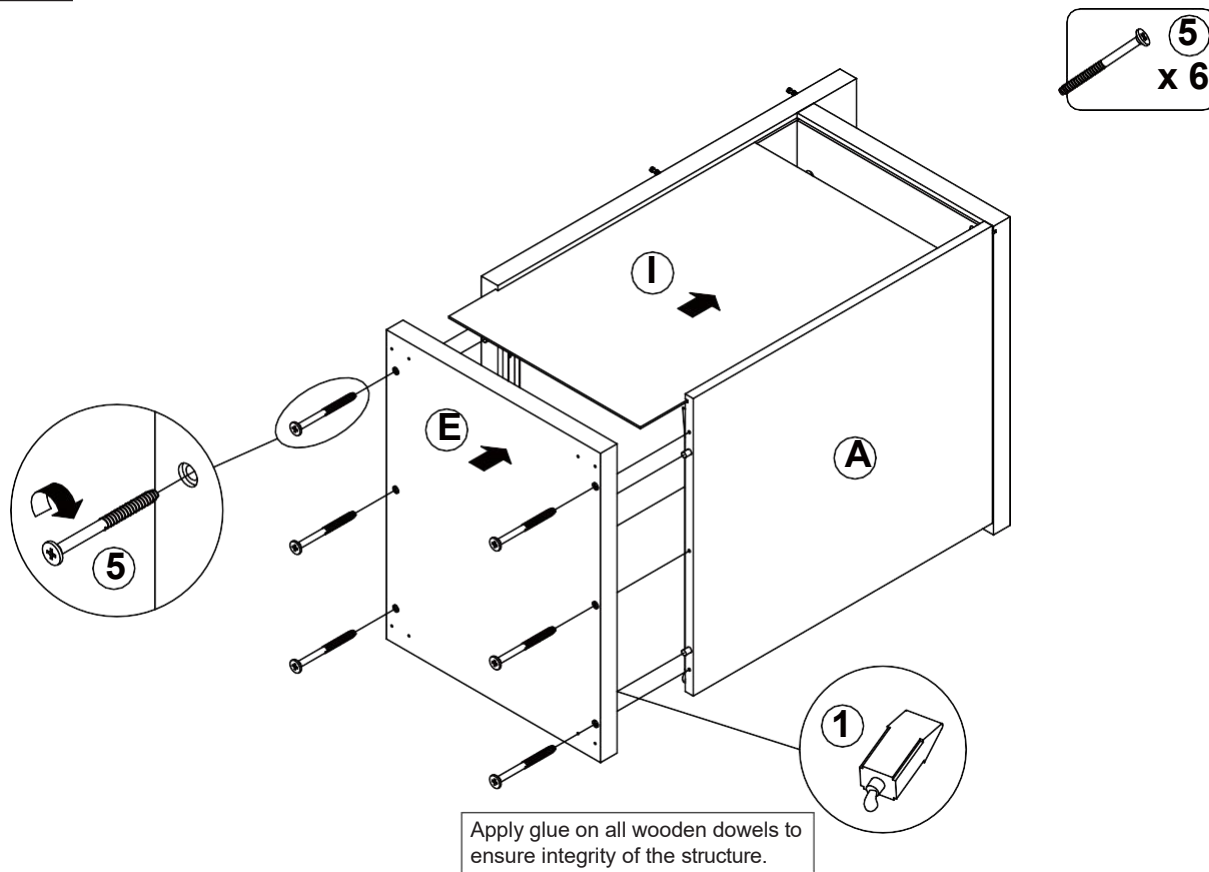

STEP 5

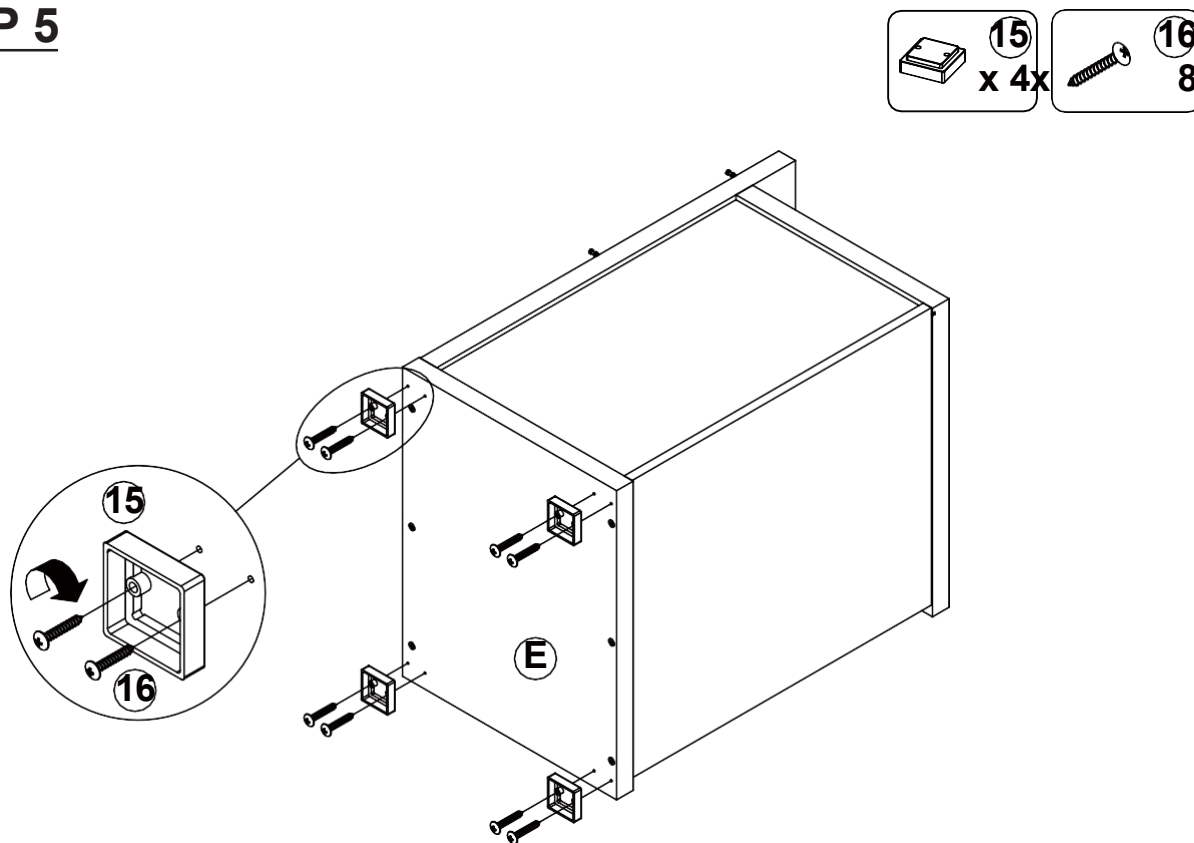

ITEM: 800108

STEP 6

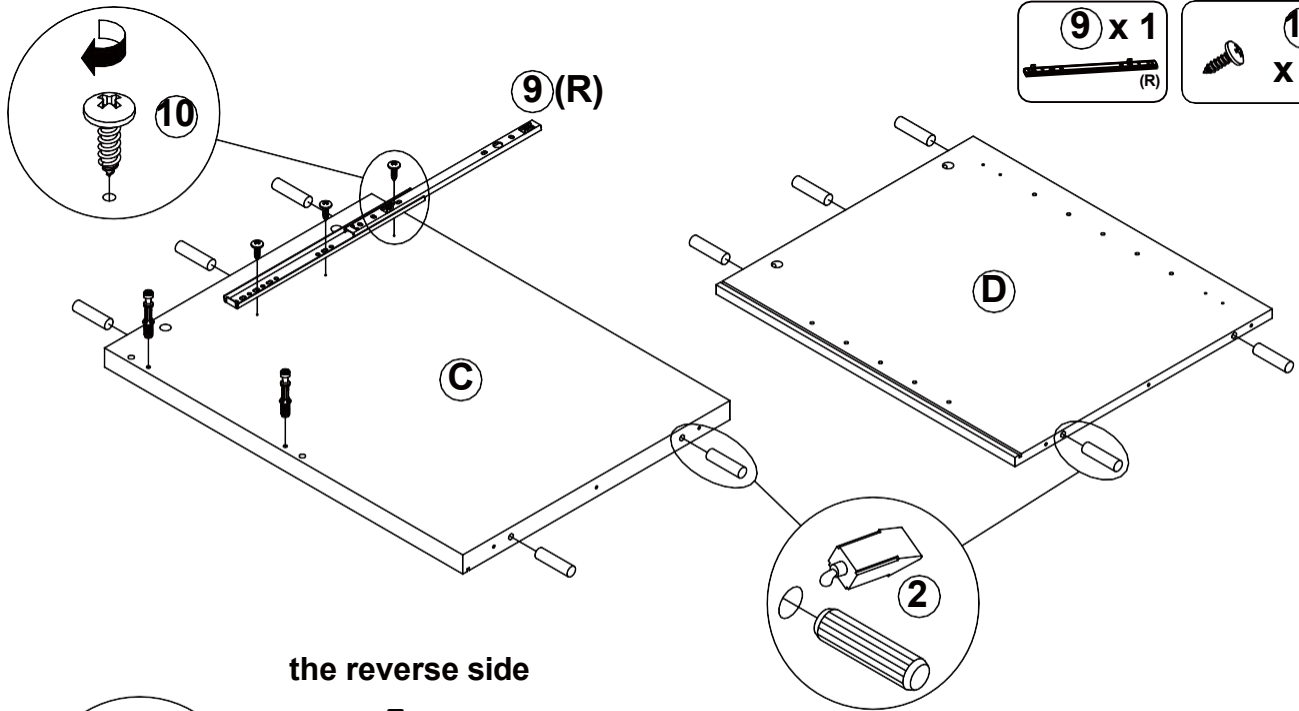
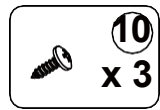
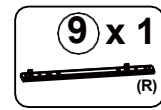
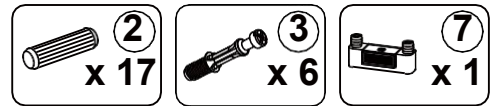

the reverse side

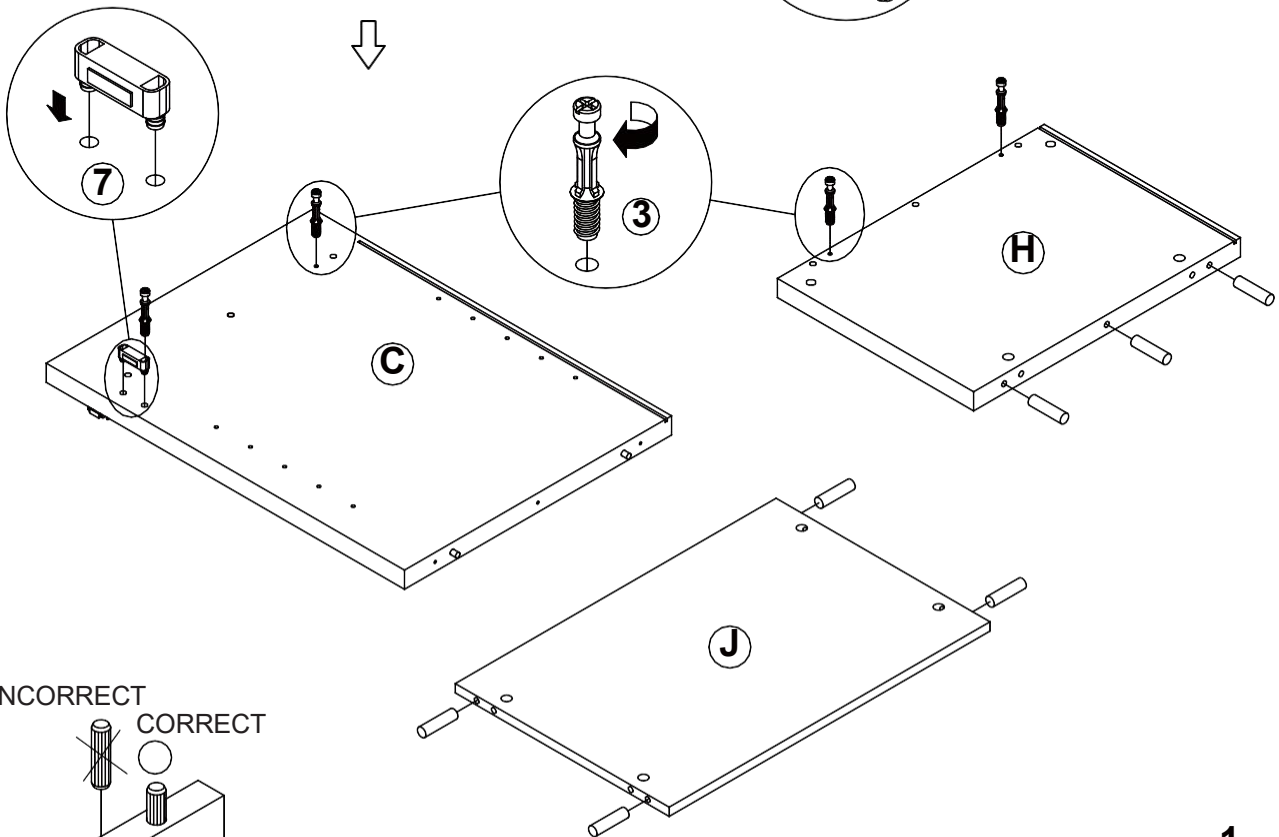

INCORRECT
CORRECT

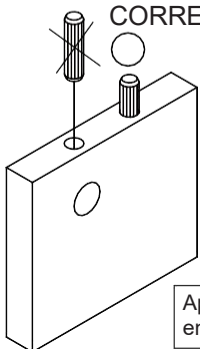

Apply glue on all wooden dowels to ensure integrity of the structure.

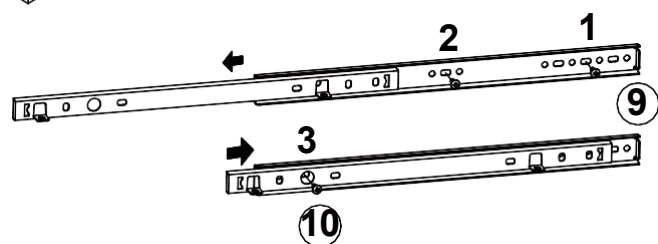

ITEM:800108

STEP 7

Apply glue on all wooden dowels to ensure integrity of the structure.

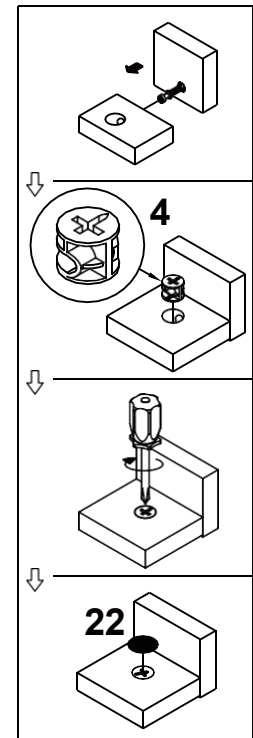
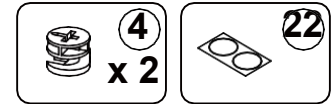
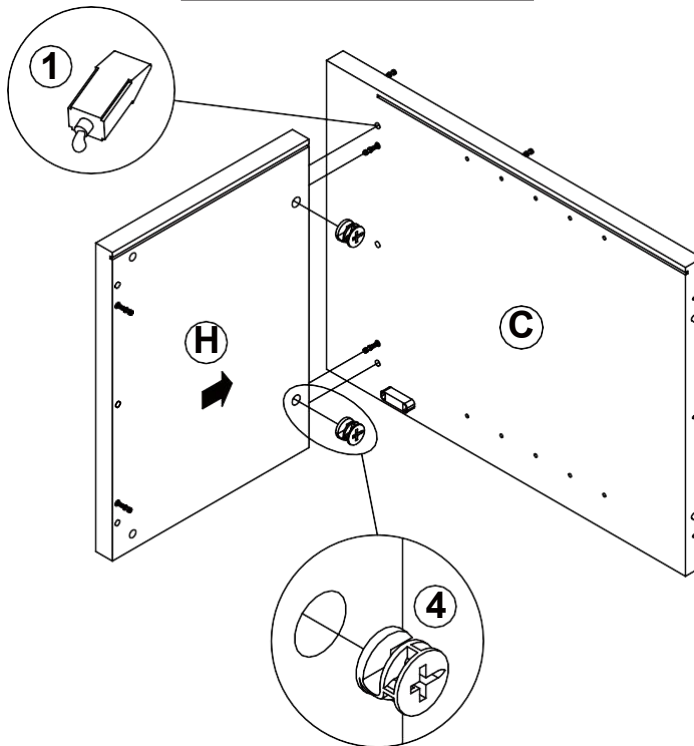

STEP 8

Apply glue on all wooden dowels to ensure integrity of the structure.

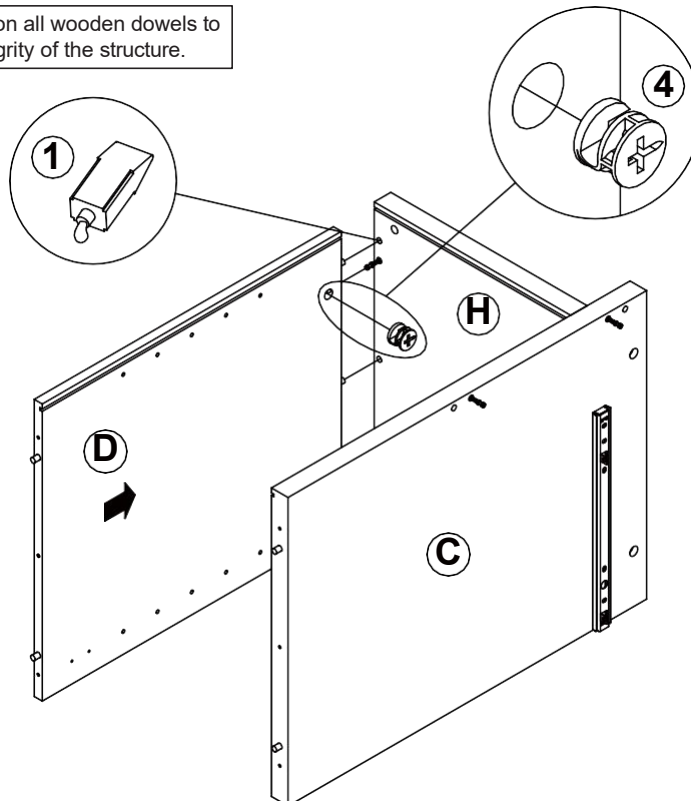

ITEM: **800108**

STEP 9

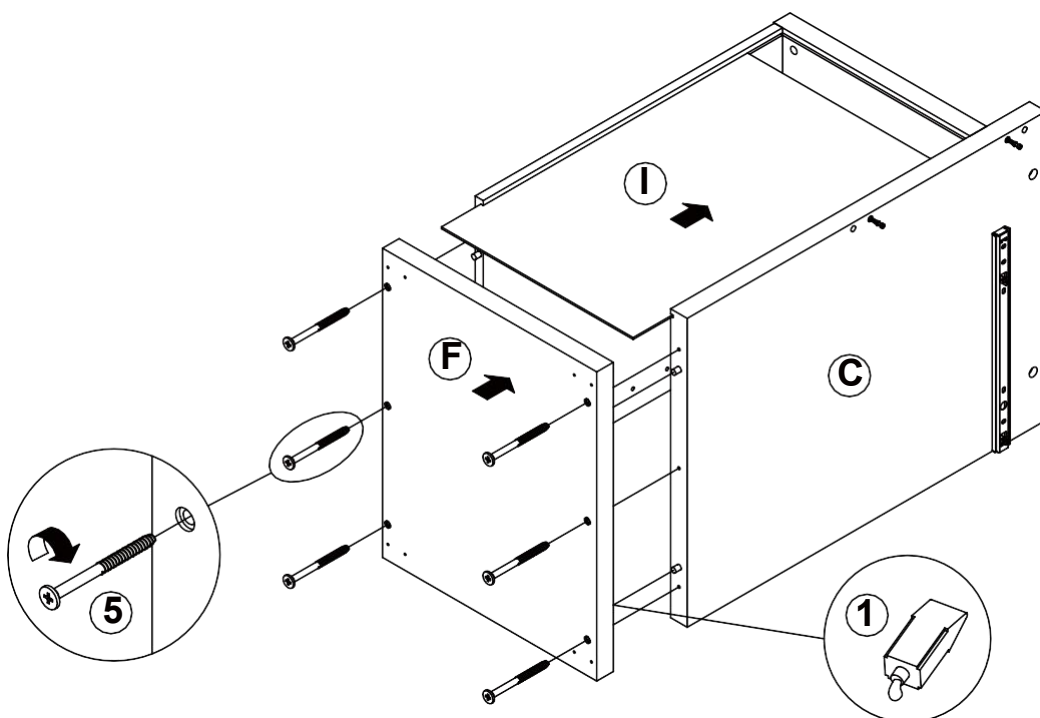
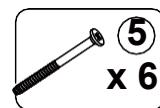

Apply glue on all wooden dowels to ensure integrity of the structure.

STEP 10

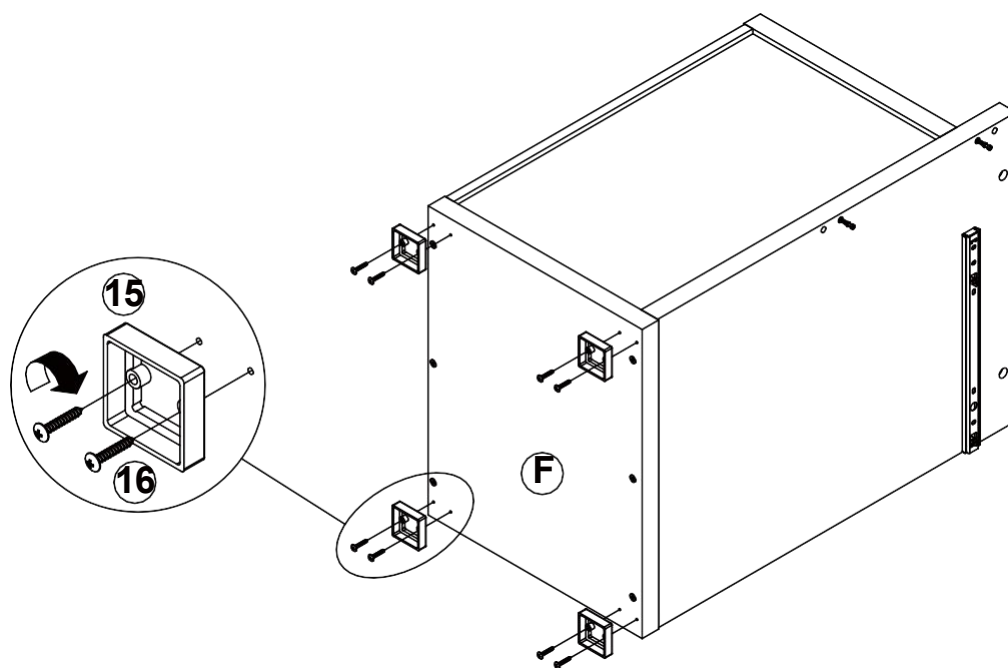
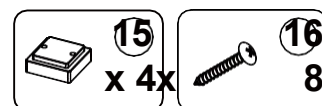

ITEM: 800108

STEP 11

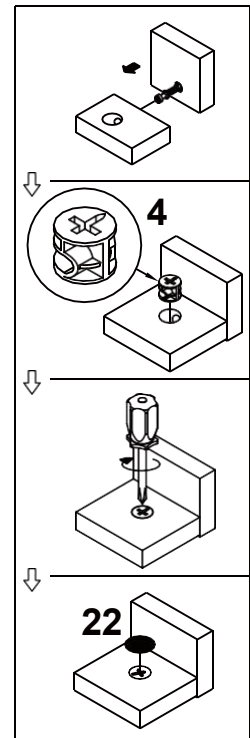
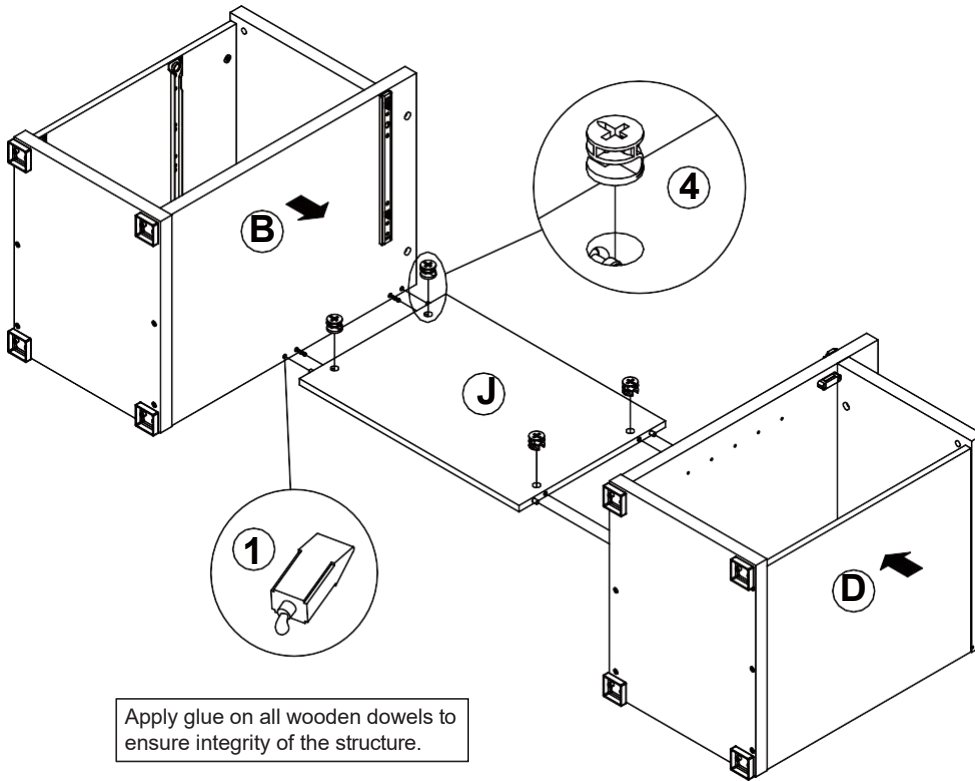
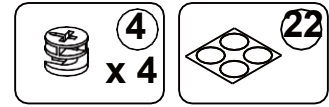

STEP 12

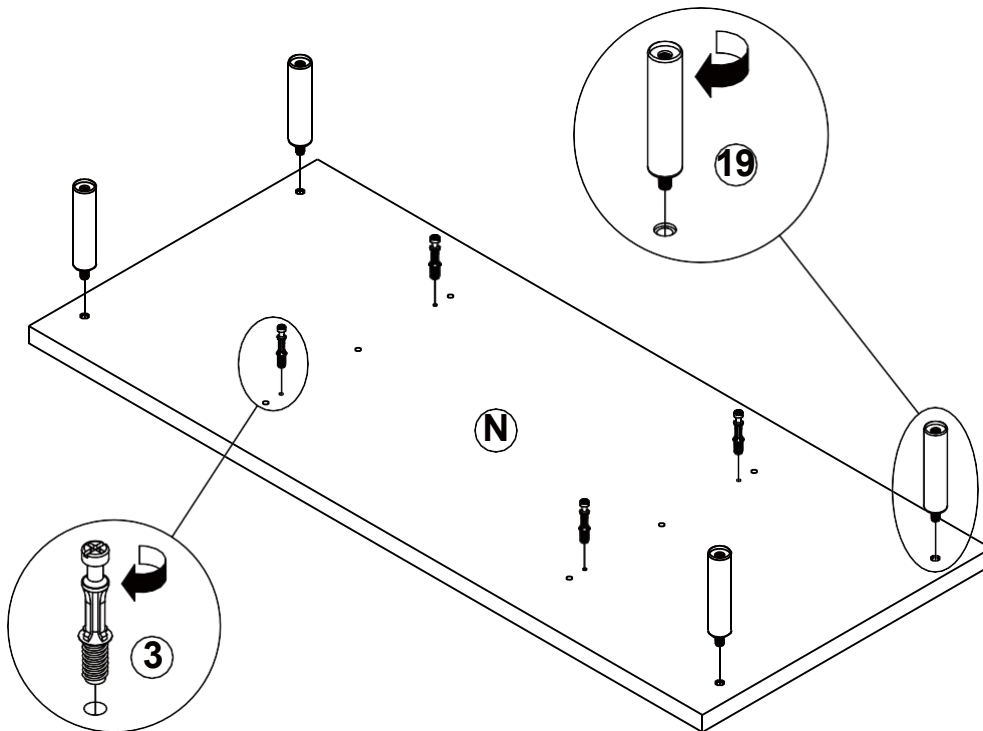
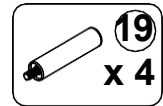
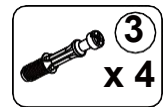

ITEM: 800108

STEP 15

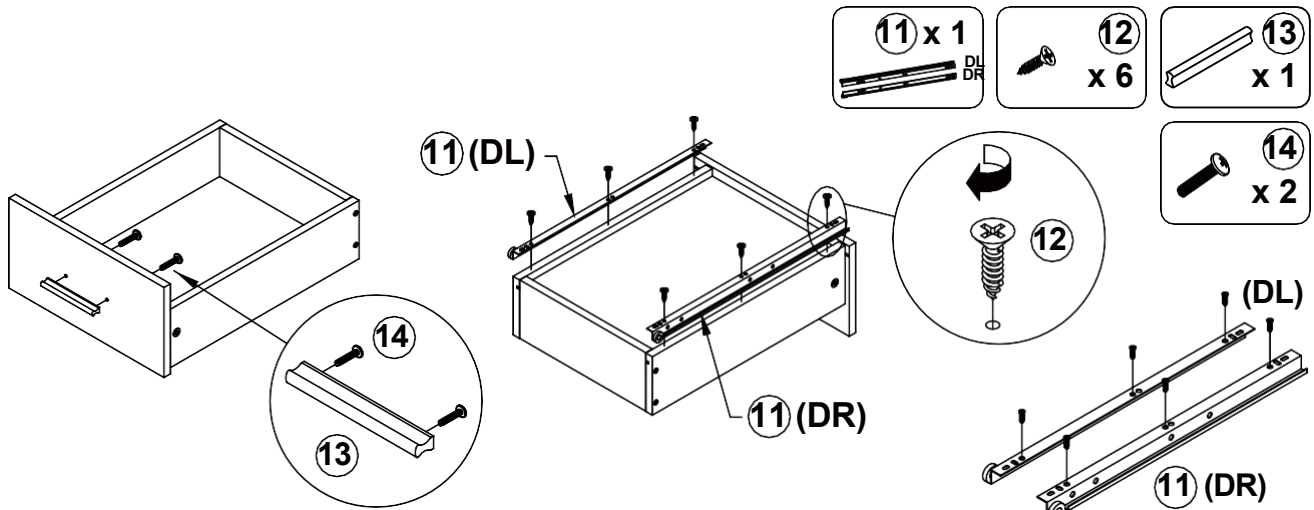

STEP 16

Apply glue on all wooden dowels to ensure integrity of the structure.

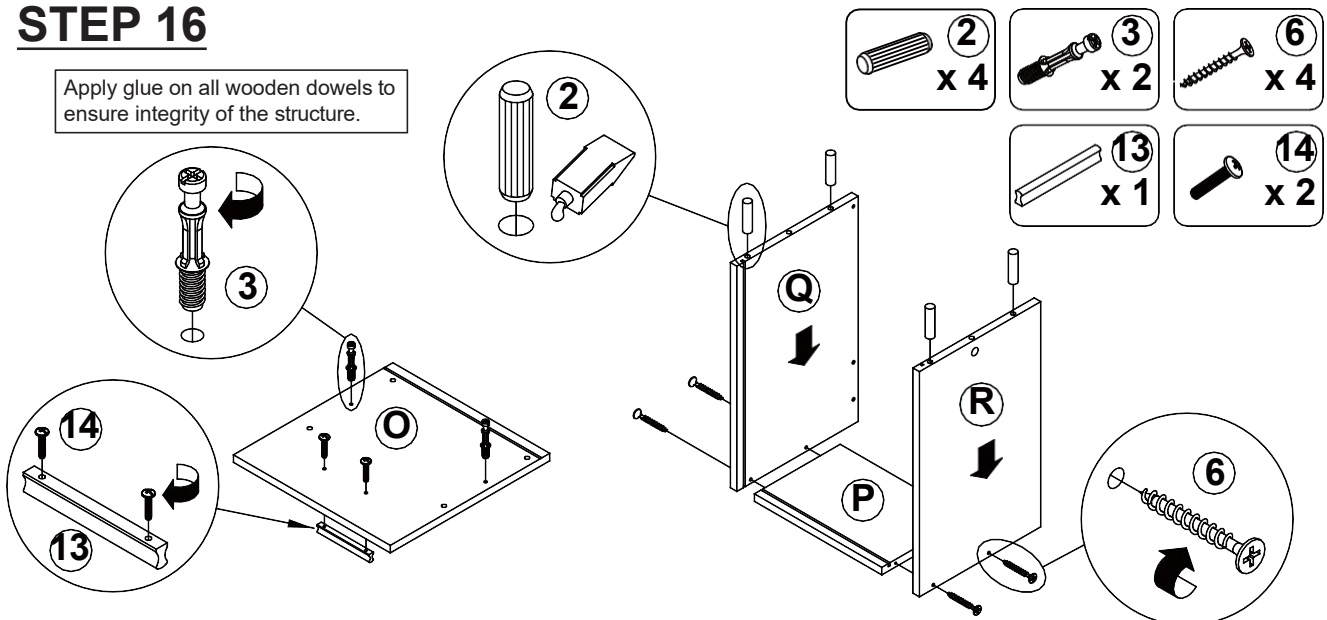

STEP 17

Apply glue on all wooden dowels to ensure integrity of the structure.

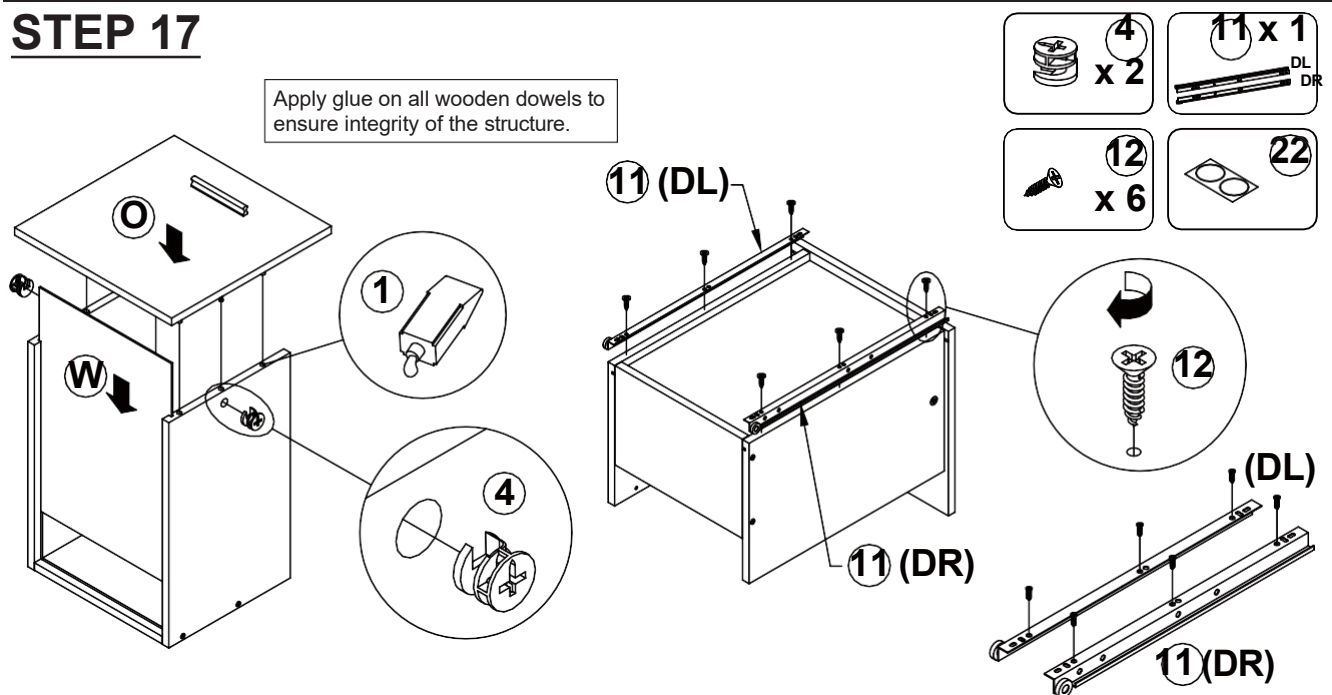

ITEM: 800108

STEP 18

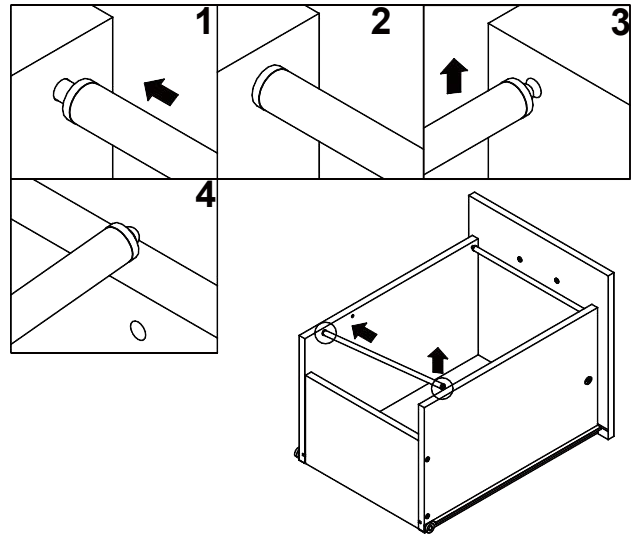
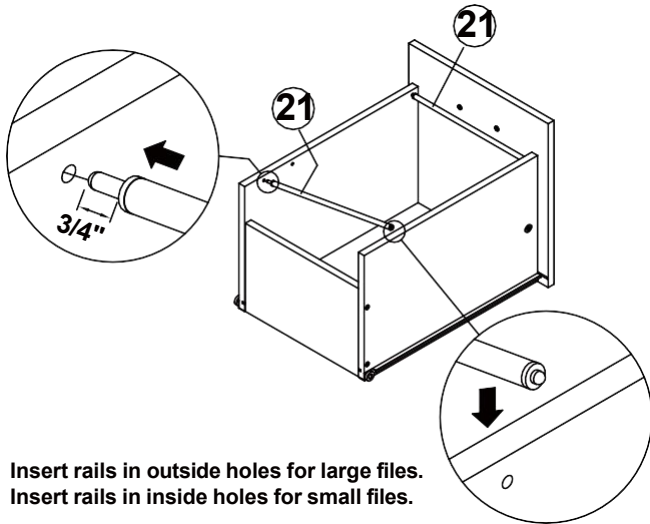

Insert rails in outside holes for large files.
Insert rails in inside holes for small files.

STEP 19

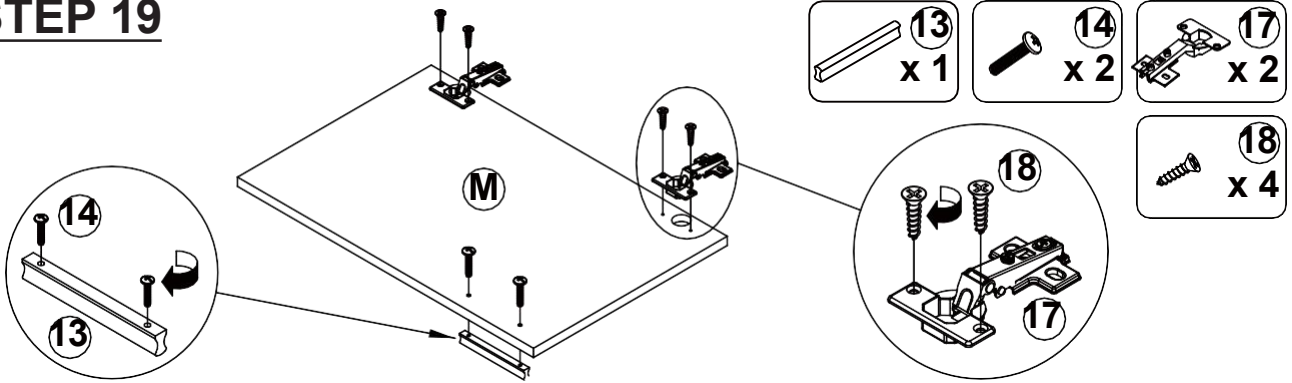

STEP 20

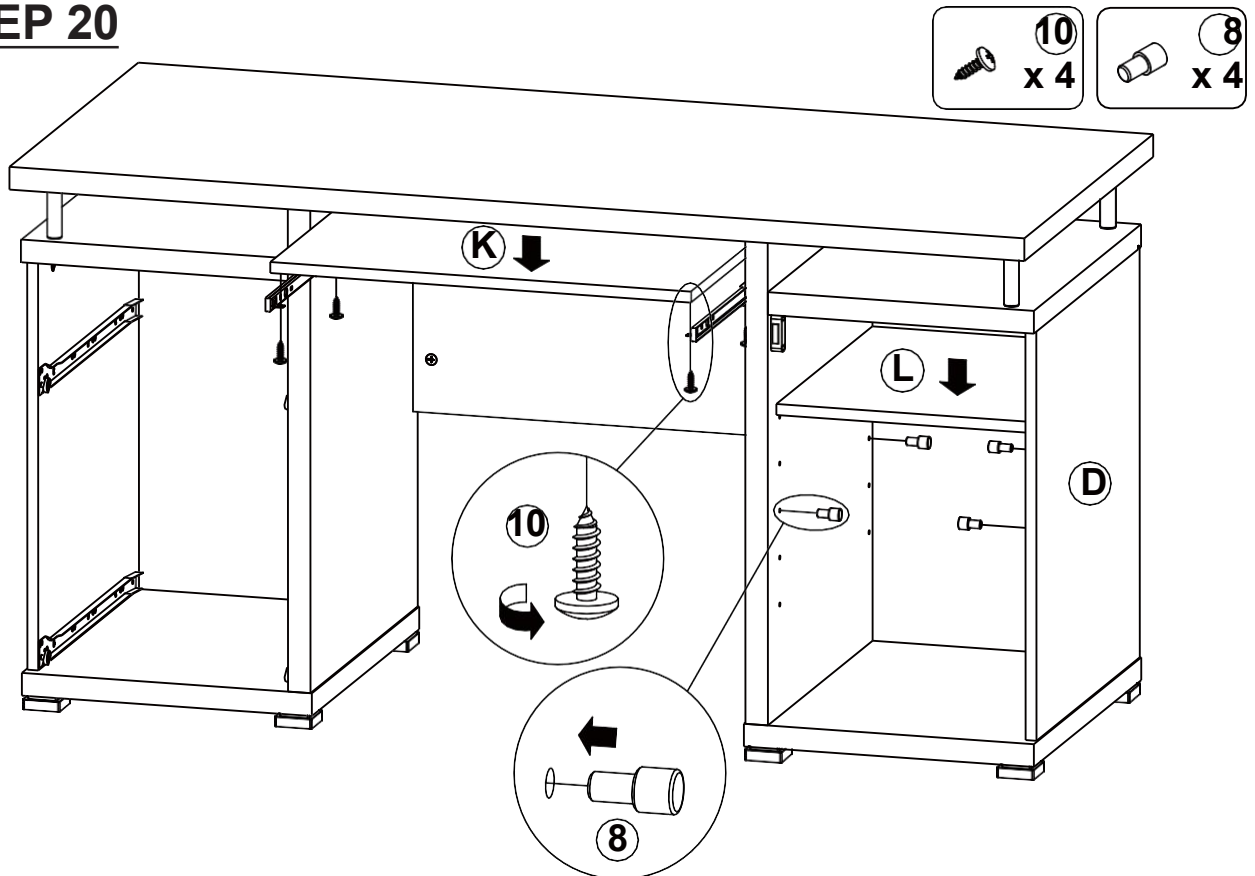

ITEM: **800108**

STEP 21

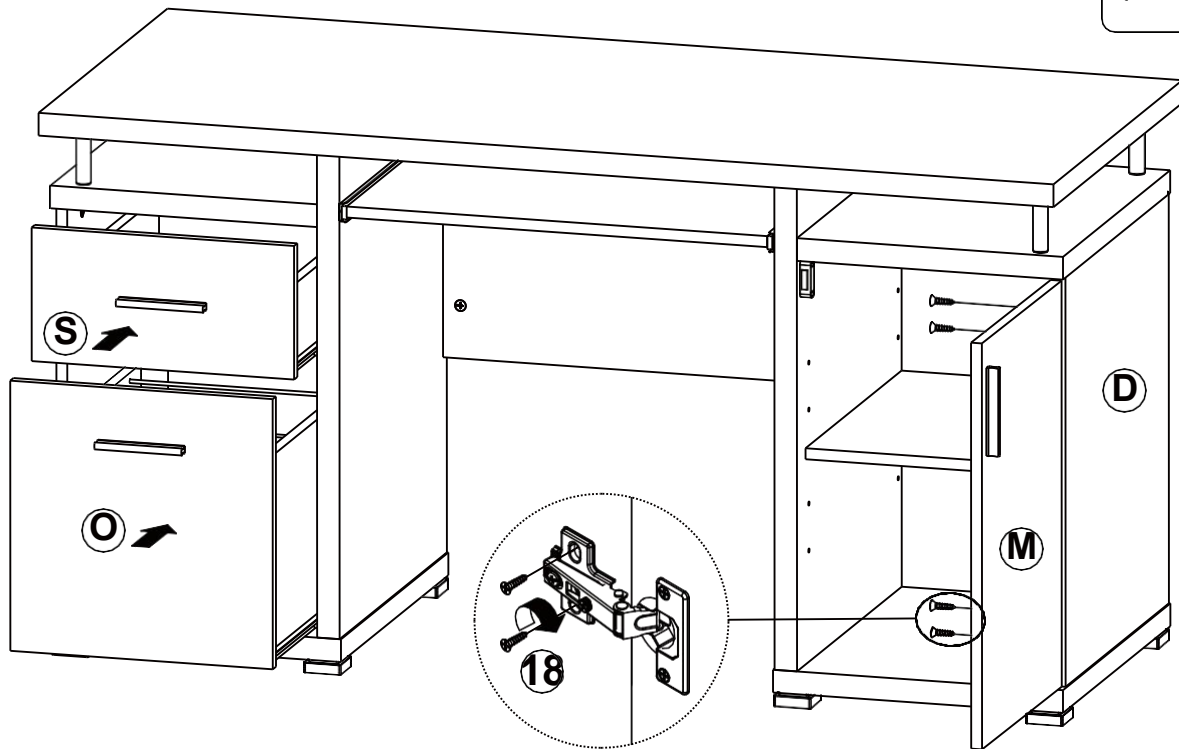

STEP 22
COMPLETE

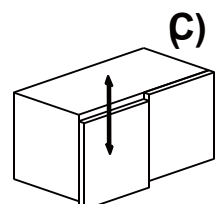
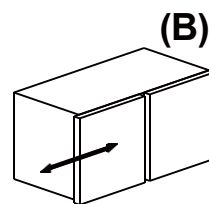
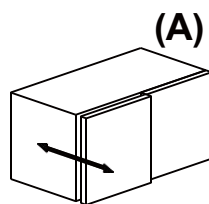
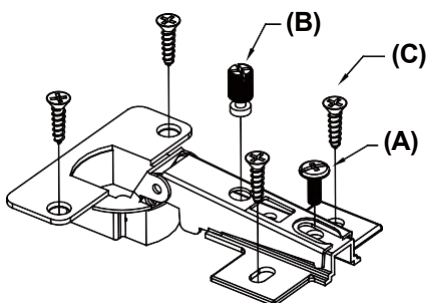
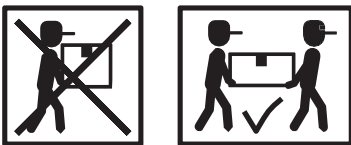
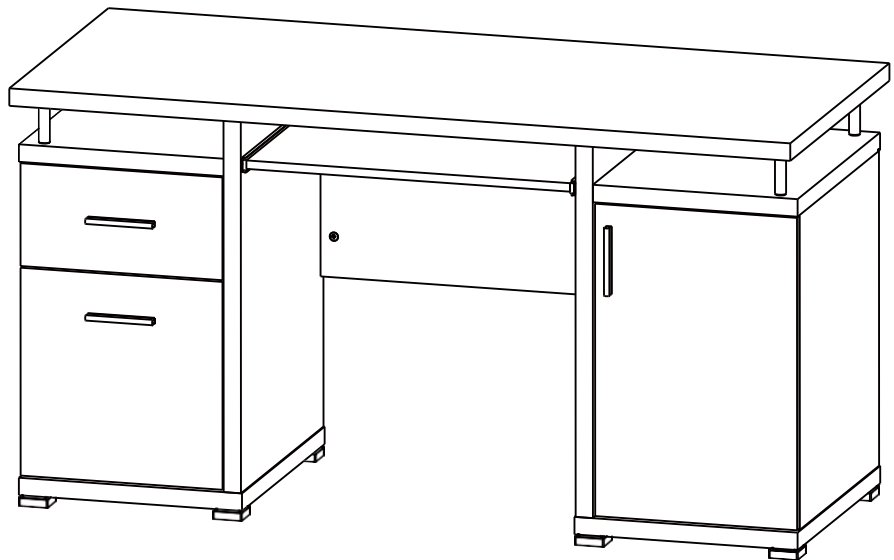

ITEM:800108

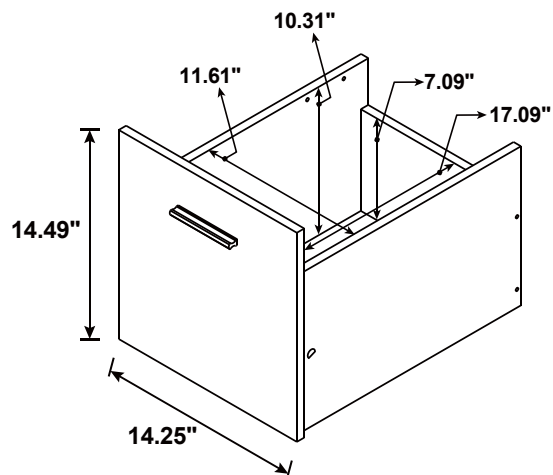
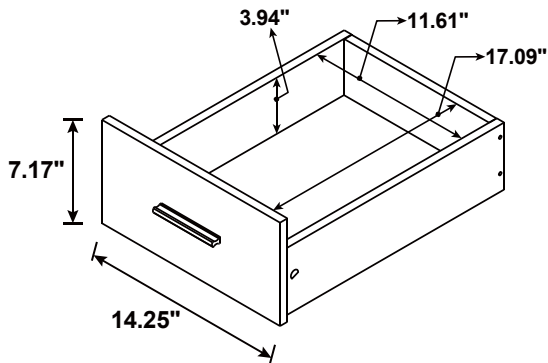
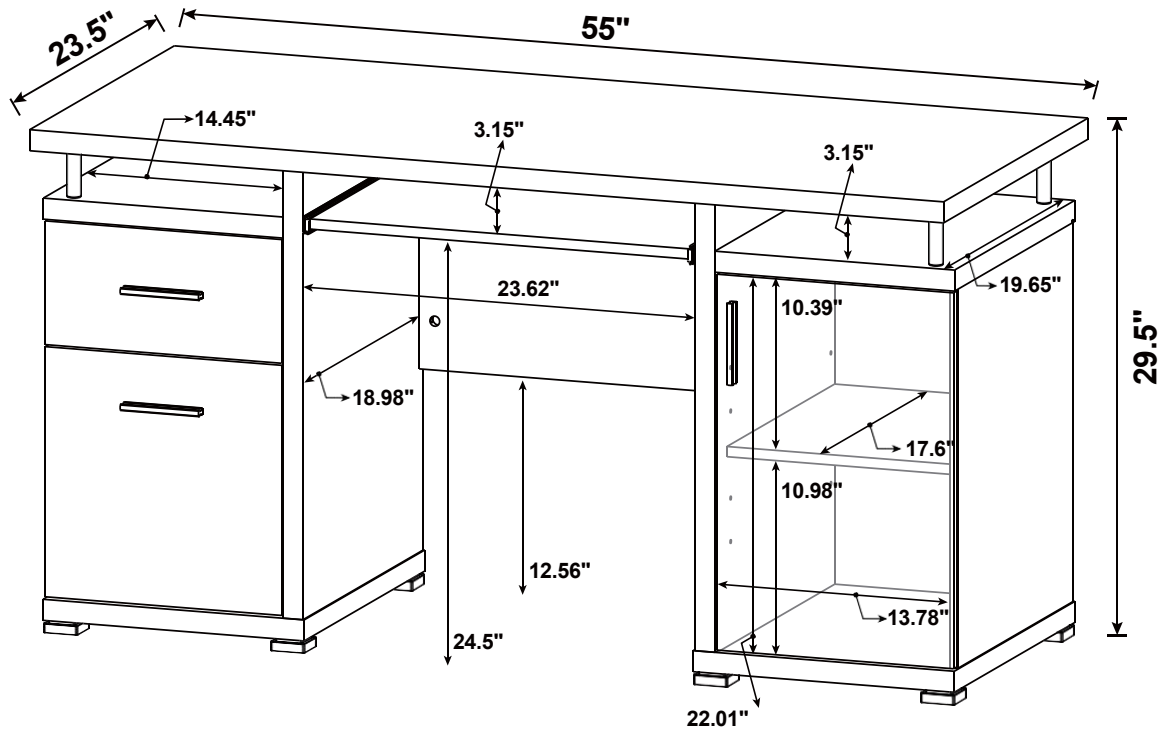

Note : Dimension tolerance $\pm 5\%$