

Montageanleitung

Notice de montage

Assembly instruction

Schuhschrank

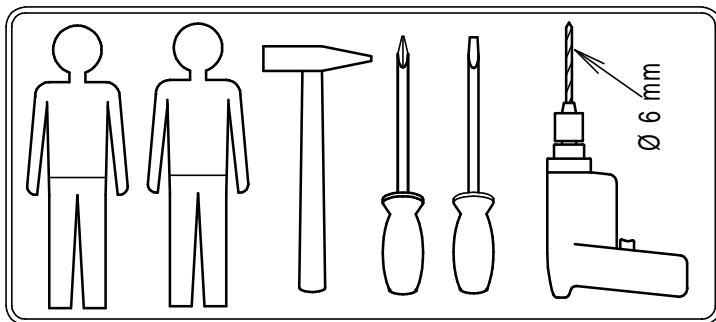
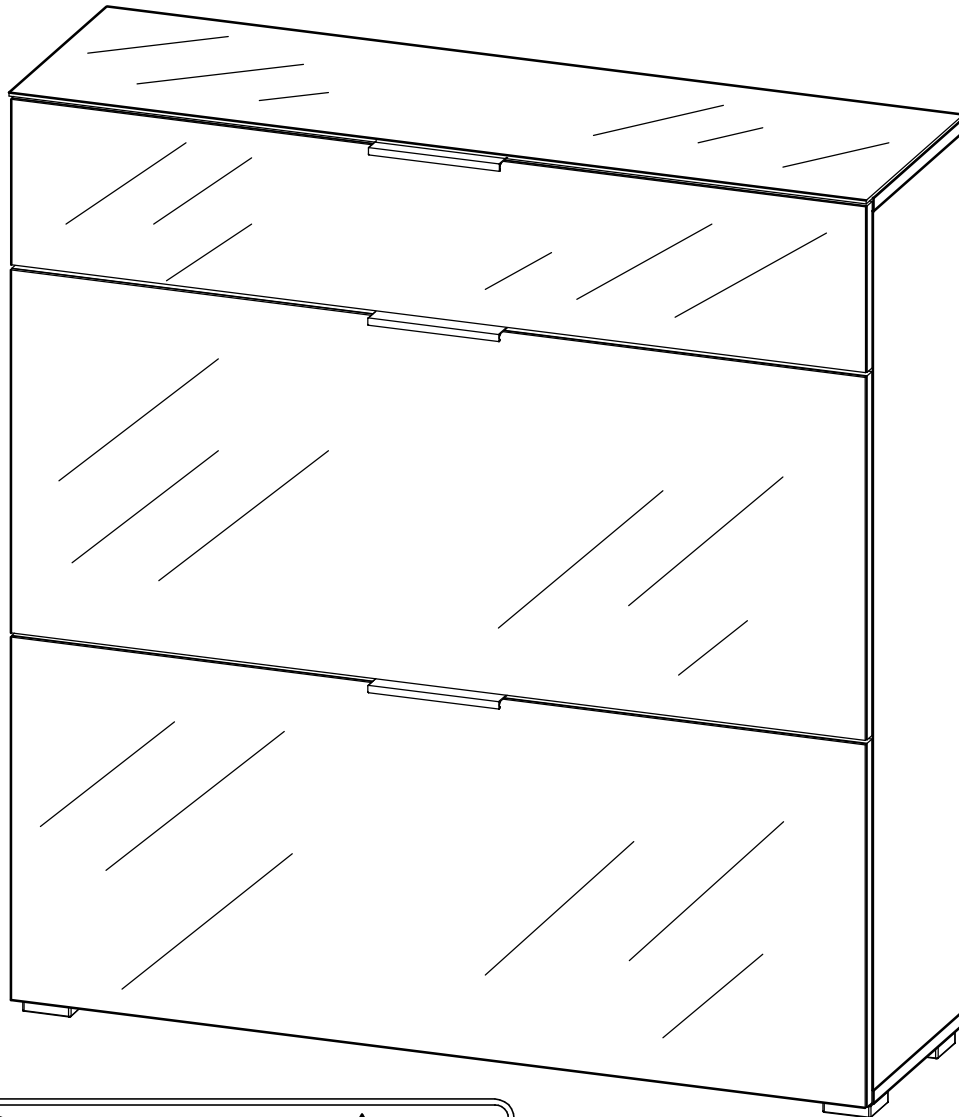

Bitte die Sicherheitshinweise auf der letzten Seite beachten!

Please note: safety instructions on the last page!

Prière de suivre les instructions de sécurité figurant sur la dernière page!

erstellt

geändert

geprüft

Teileliste - liste de pièces - partlist

2218

12x



Ø8 x 30mm

1116

12x



Ø15mm

1114

12x

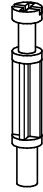

24 mm

1162

8x



5572

3x

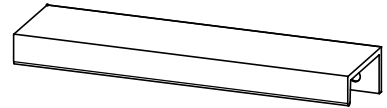

Teilung = 128 mm

5403

4x

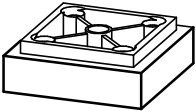

55x55 mm

1071

8x



Ø4x30mm

4220

2x

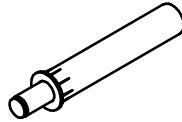

4221

2x

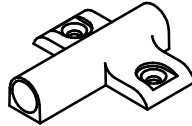

5598

1x

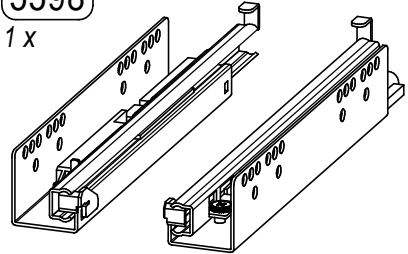

250 mm

5493

2x

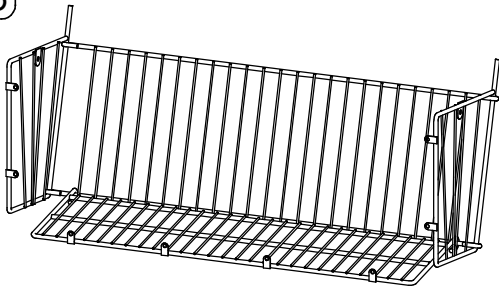

941 x 244 x 250 mm

5494

2x

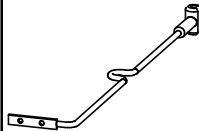

Ø4x247mm

1075

4x



Ø3x13mm

4271

1x

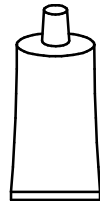

1238

16x



Ø6,3x13

1236

14x



Ø6,3x11

5333

4x

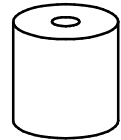

Ø20/Ø6,3x20

4836

1x

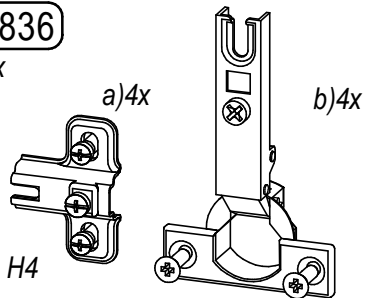

H4

4095

4x

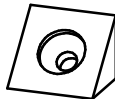

10x10x13mm

1058

4x



Ø3x15mm

1267

6x

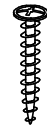

Ø3x16

1416

4x

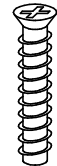

Ø6,3x30

1187

1x



90x30x15

1298

2x

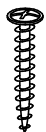

Ø4x15mm

1110

1x



Ø6x30mm

1021

1x

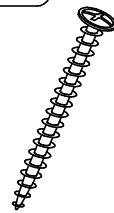

Ø4,5x40mm

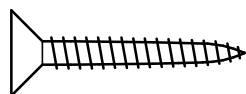

2

erstellt

geändert

geprüft

Teileliste - liste de pièces - partlist

⓪ 1x

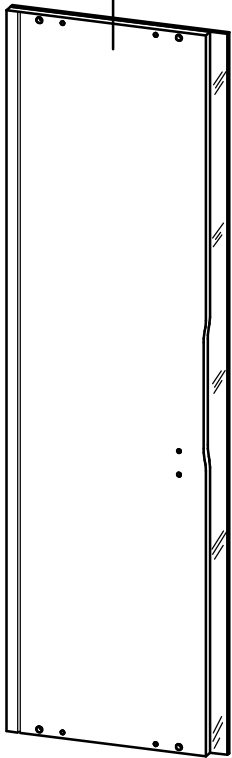

Ⓛ 1x

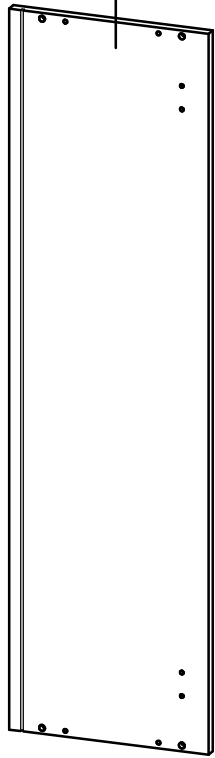

Ⓥ 1x

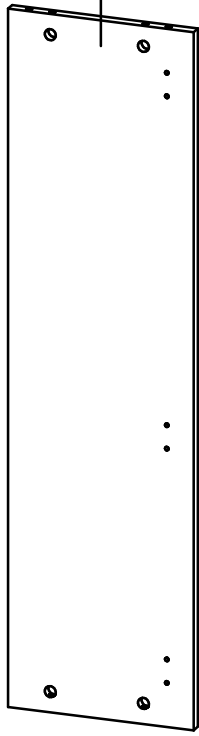

Ⓢ 1x

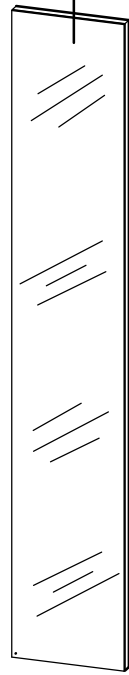

Ⓚ 2x

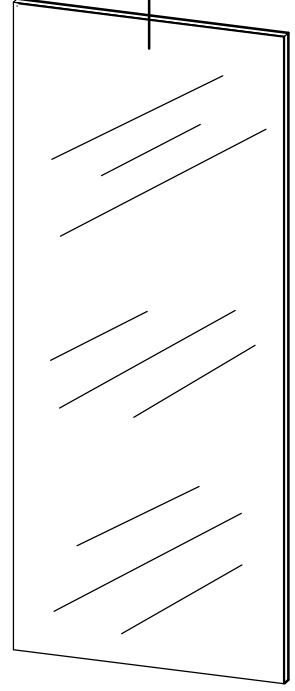

Ⓛ 1x

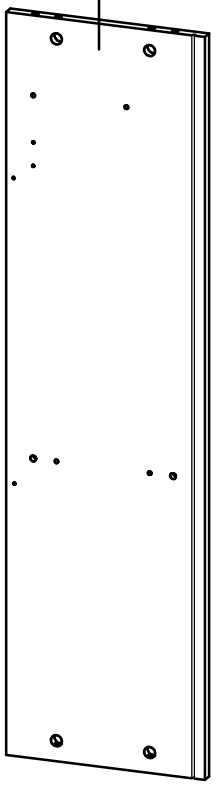

Ⓡ 1x

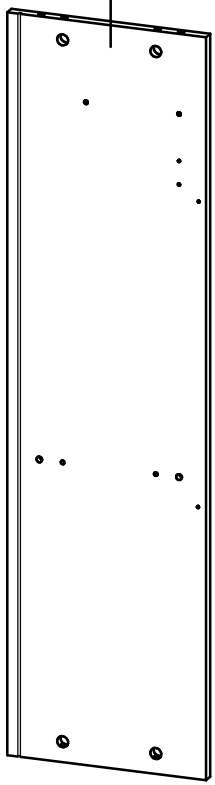

Ⓦ 1x

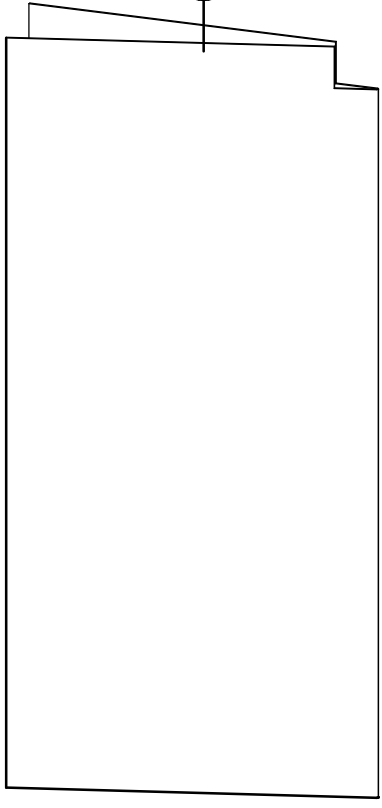

Ⓟ 1x

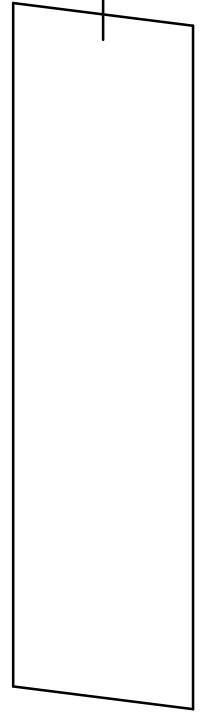

Ⓩ 1x

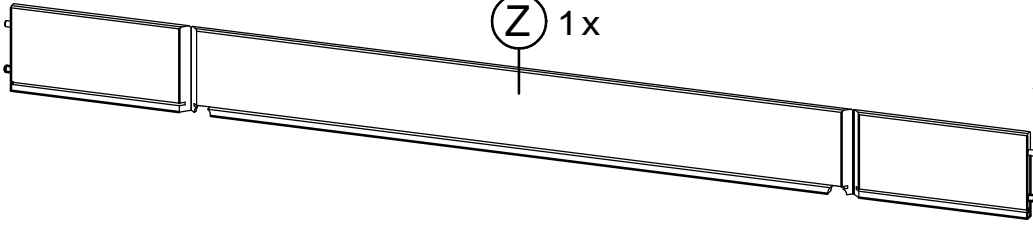

Montageschritte - ordre de montage - assembly instructions

1.

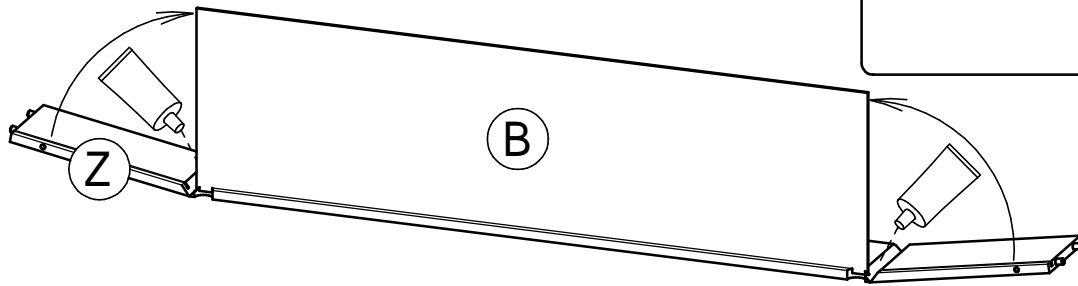
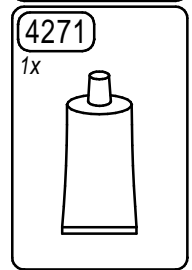
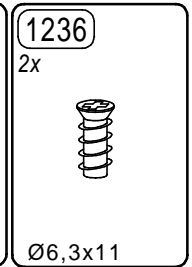
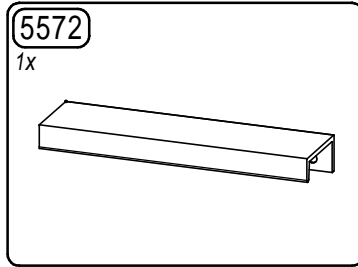

30 min.

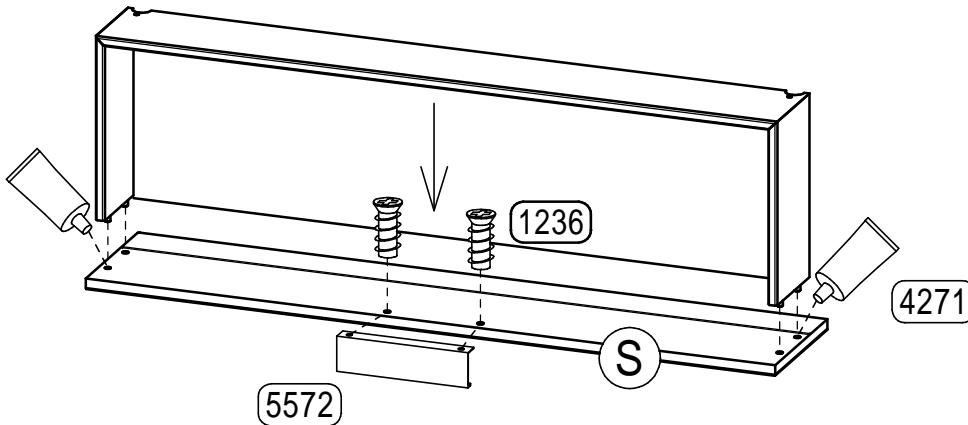
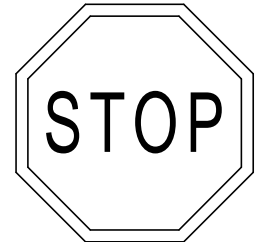

2.

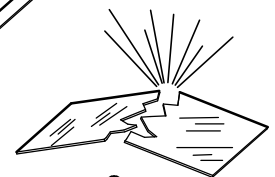
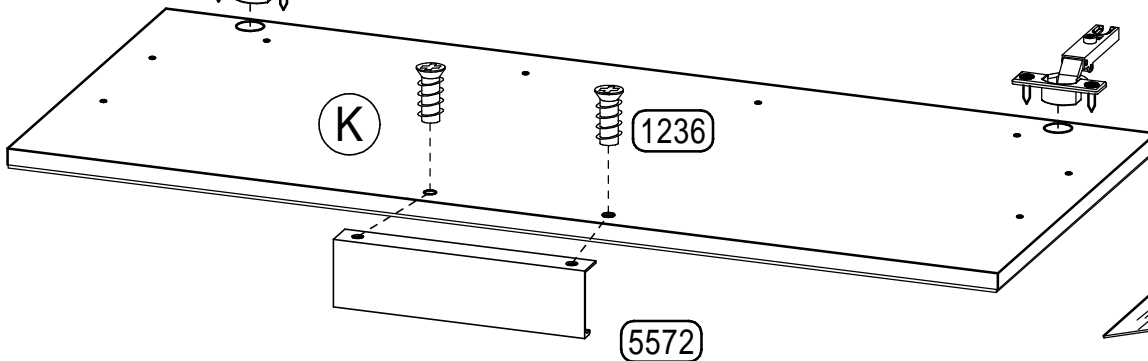
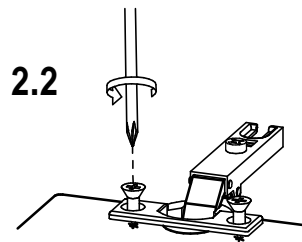
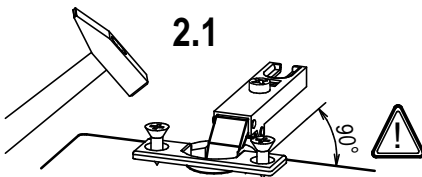
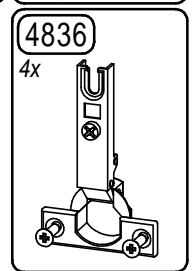
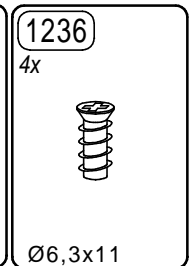
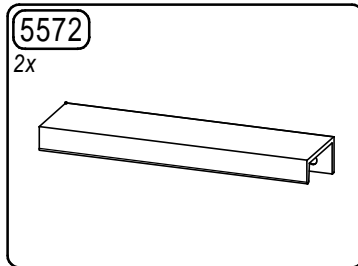

4

erstellt

geändert

geprüft

Montageschritte - ordre de montage - assembly instructions

3.

2x

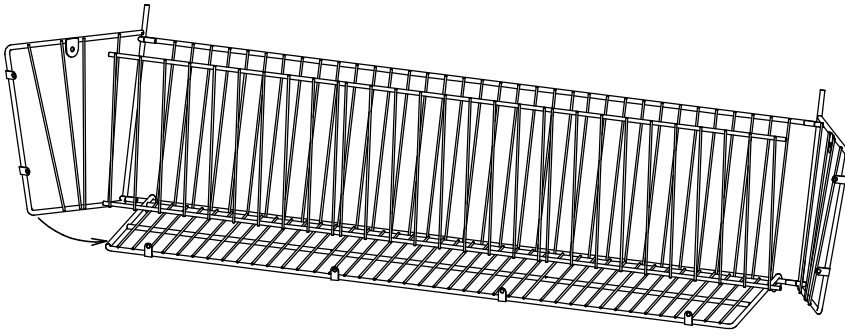

5493

2x

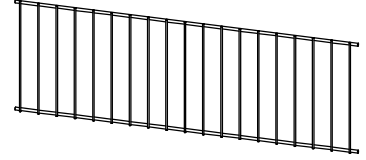
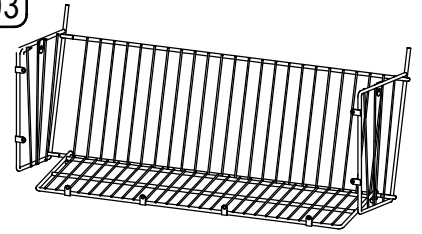

941 x 244 x 250 mm

1238

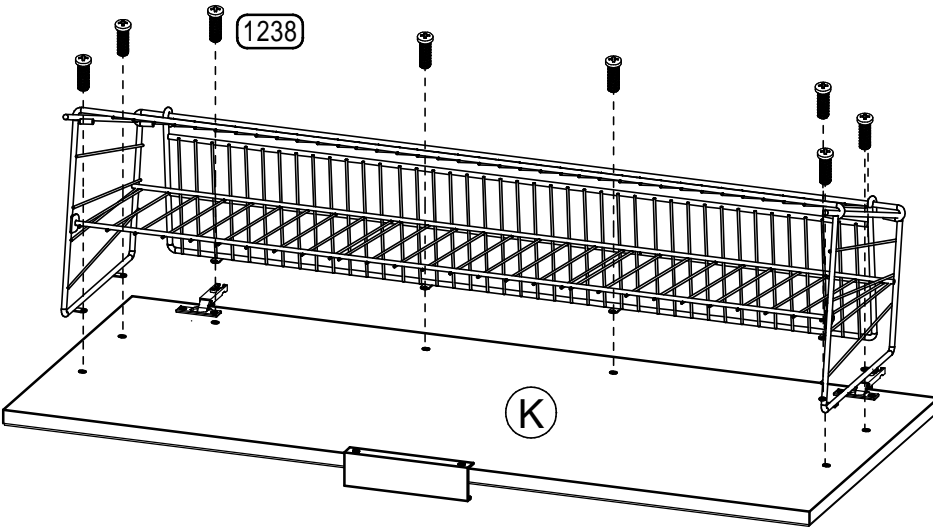

5494

2x

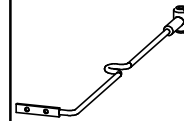

Ø4x247mm

1238

16x



Ø6,3x13

1075

4x



Ø3x13mm

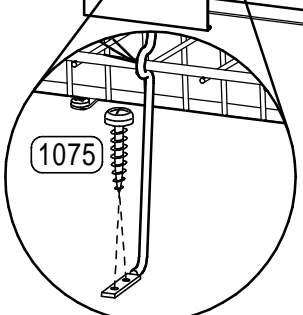
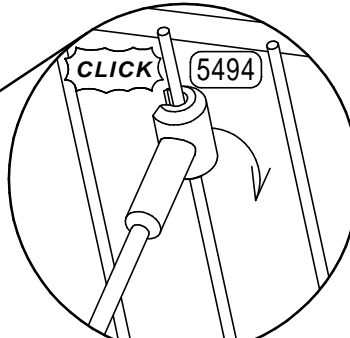

5

erstellt

geändert

geprüft

Montageschritte - ordre de montage - assembly instructions

4.

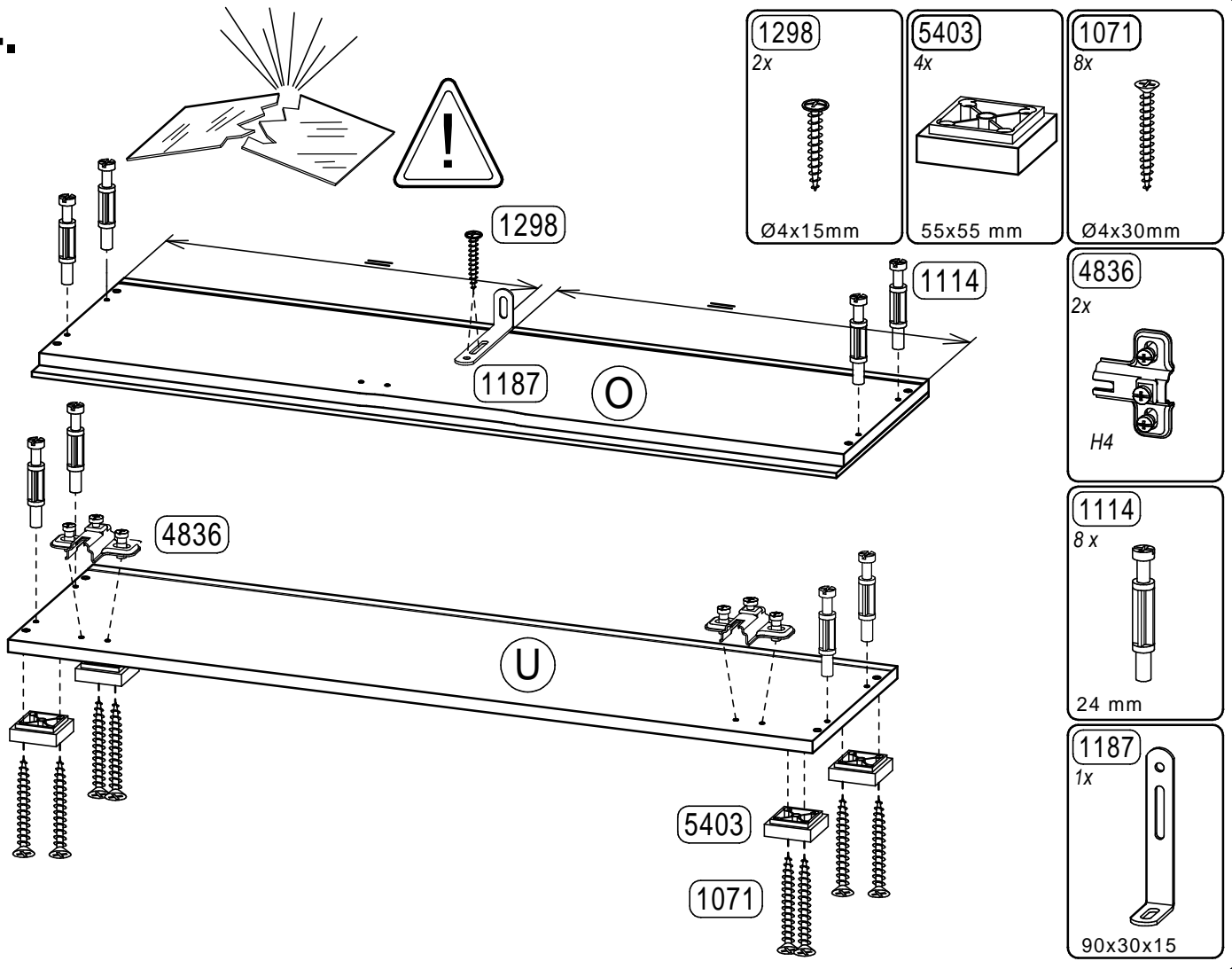

5.

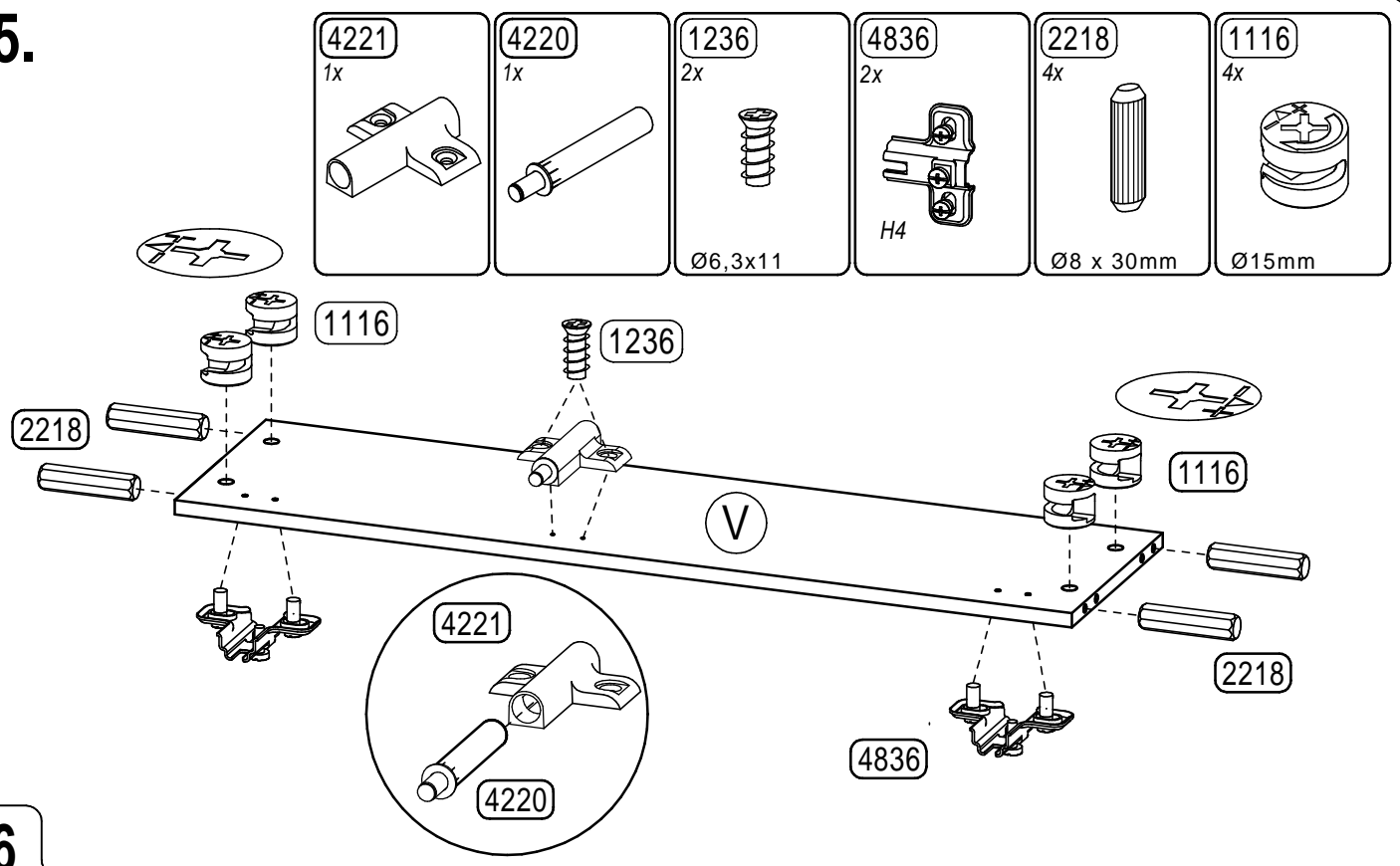

6

erstellt	geändert	geprüft

Montageschritte - ordre de montage - assembly instructions

6.

2218
8 x
Ø8 x 30mm

4220
1x

4221
1x

5598
1 x
250 mm

1236
6 x
Ø6,3x11

1116
8 x
Ø15mm

1114
4x
24 mm

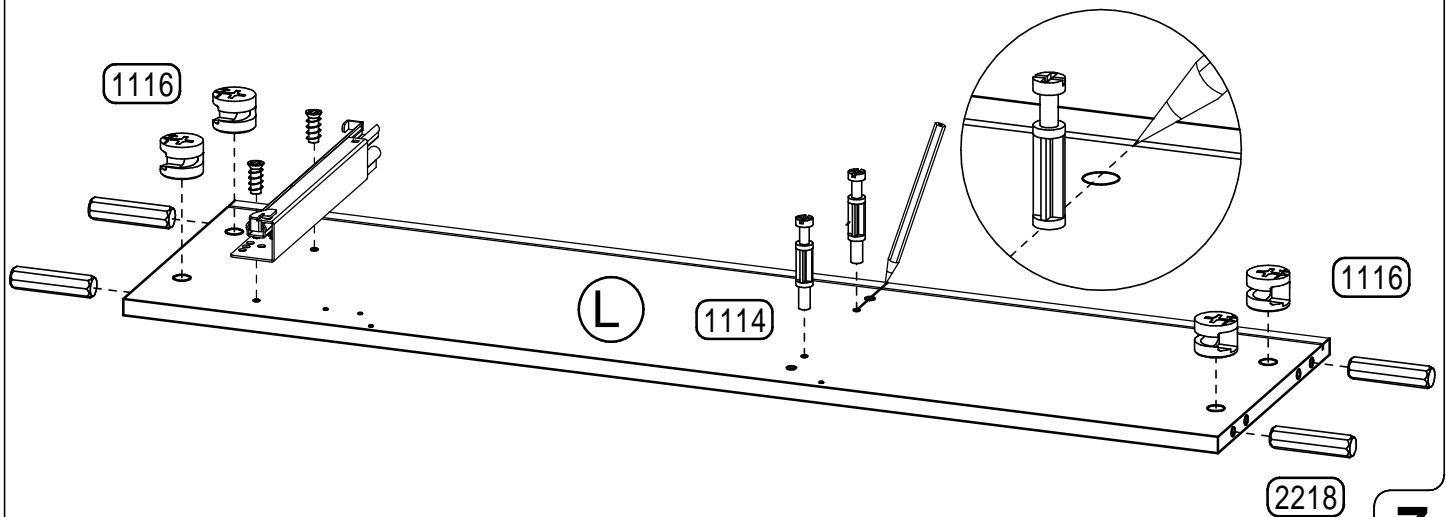
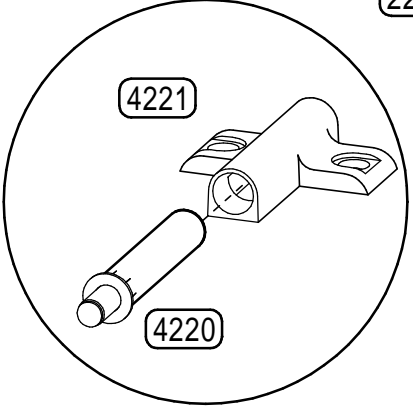
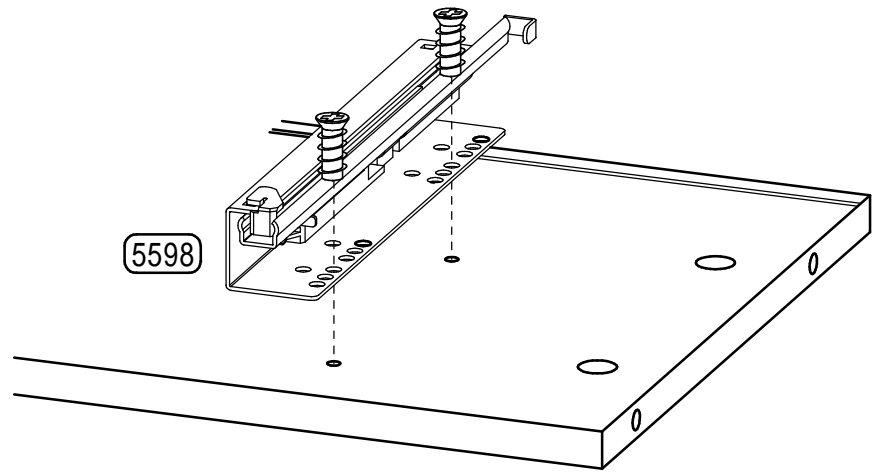
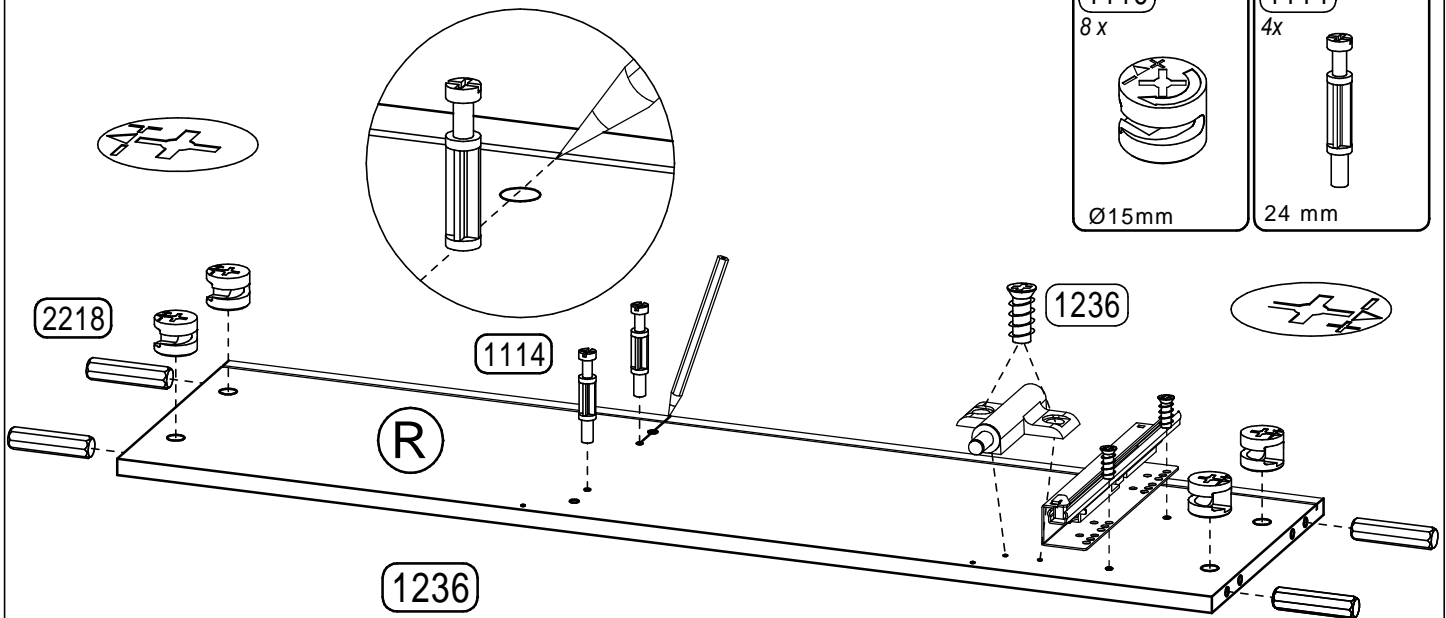

7

erstellt

geändert

geprüft

Montageschritte - ordre de montage - assembly instructions

7.

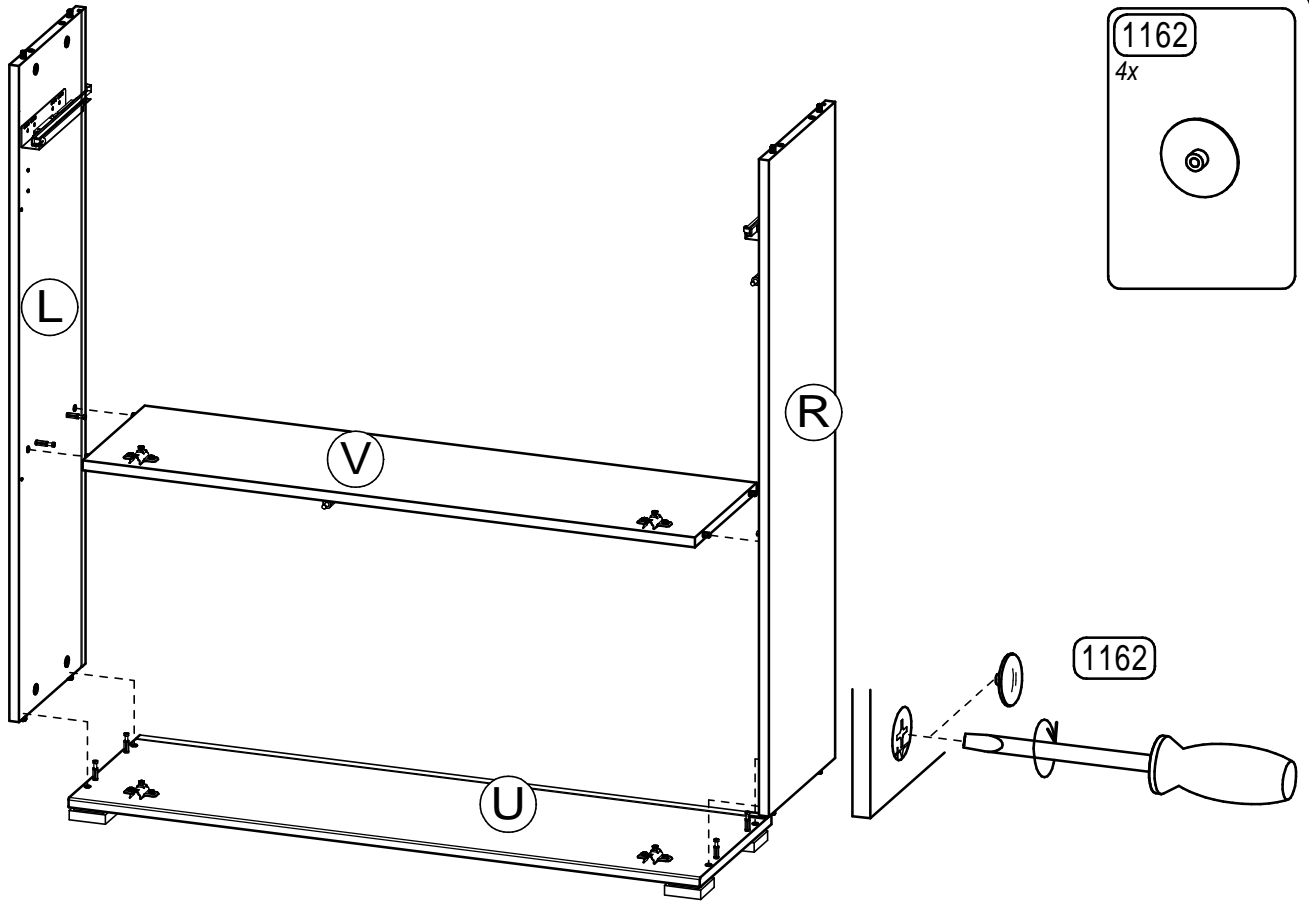

8.

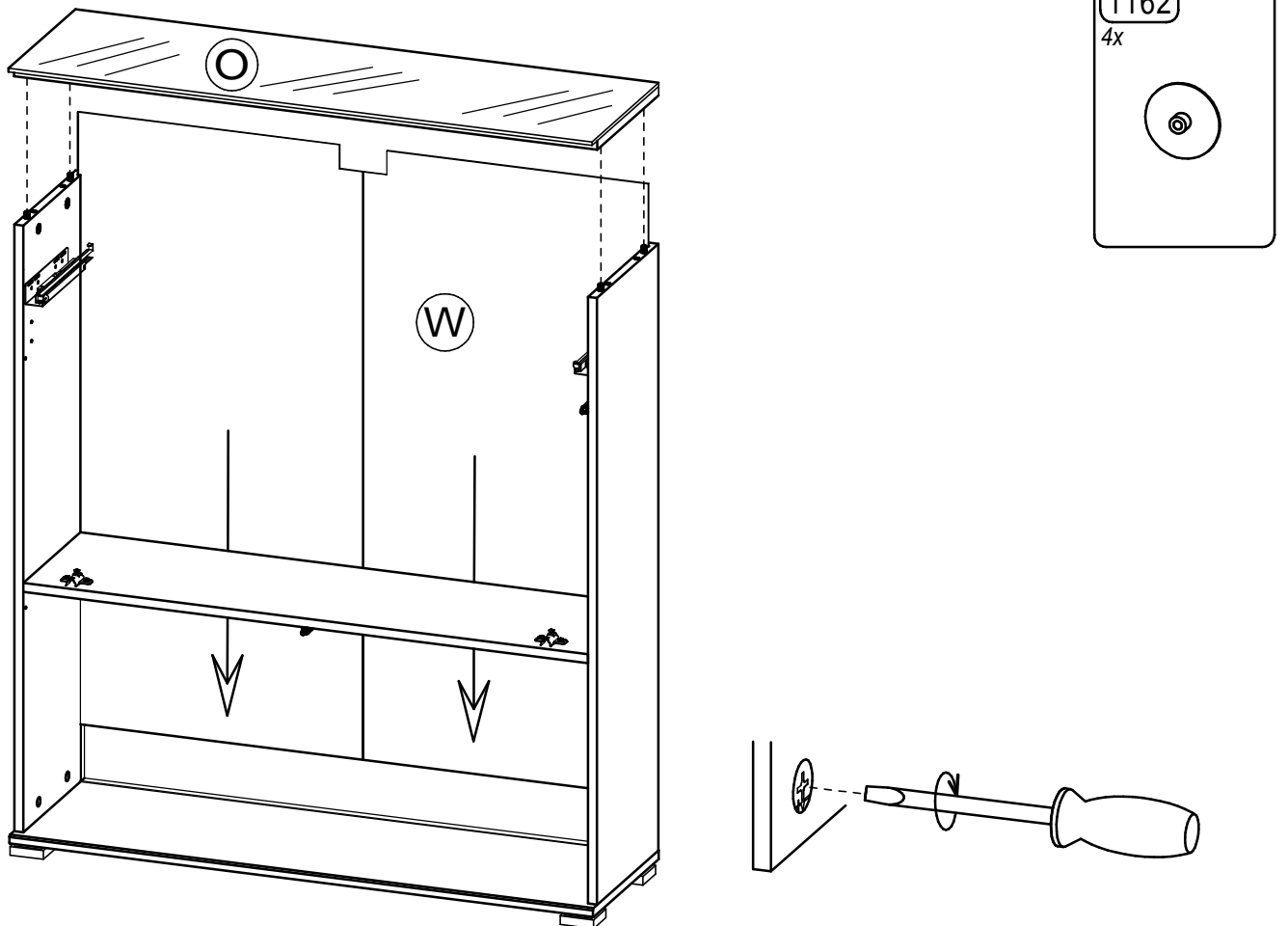

8

erstellt

geändert

geprüft

Montageschritte - ordre de montage - assembly instructions

9.

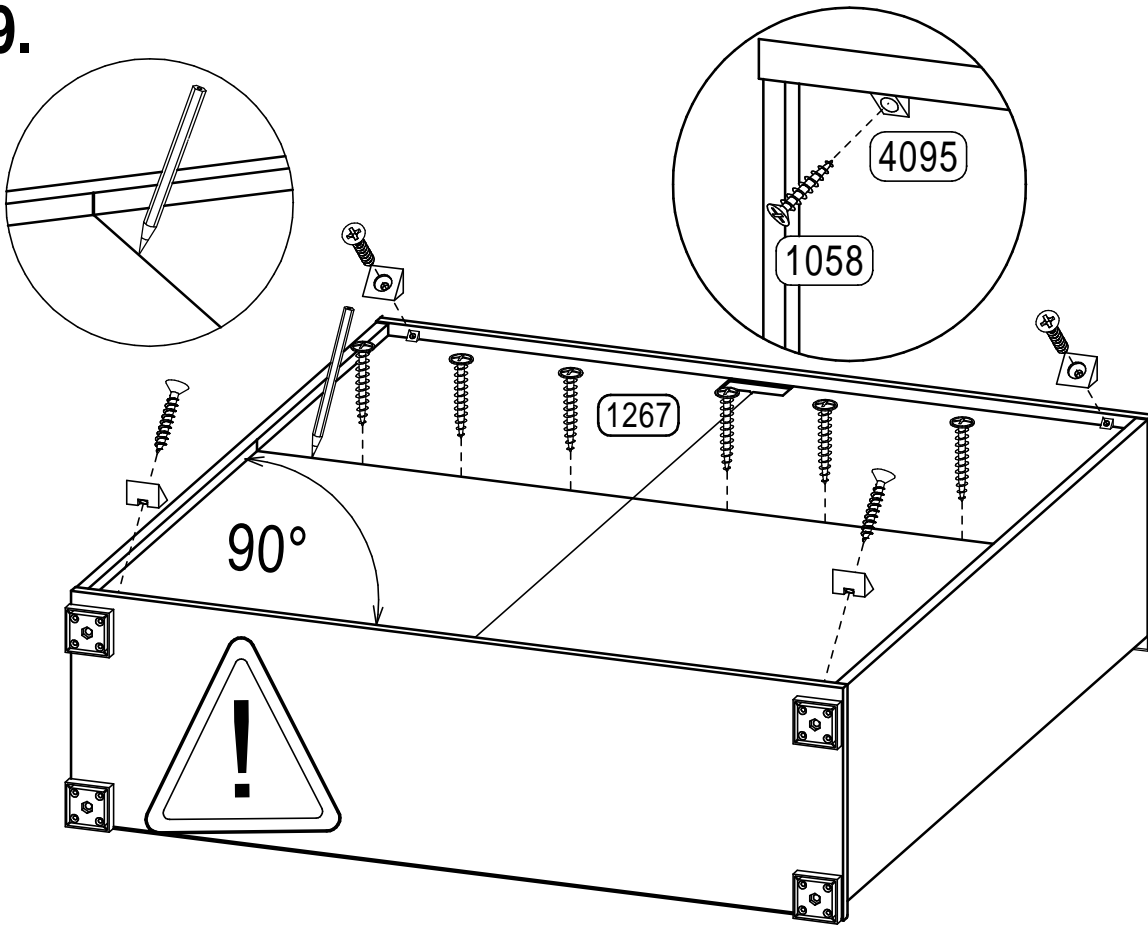

4095

4x



1058

4x



Ø3x15mm

1267

6x

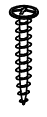

Ø3x16

10.

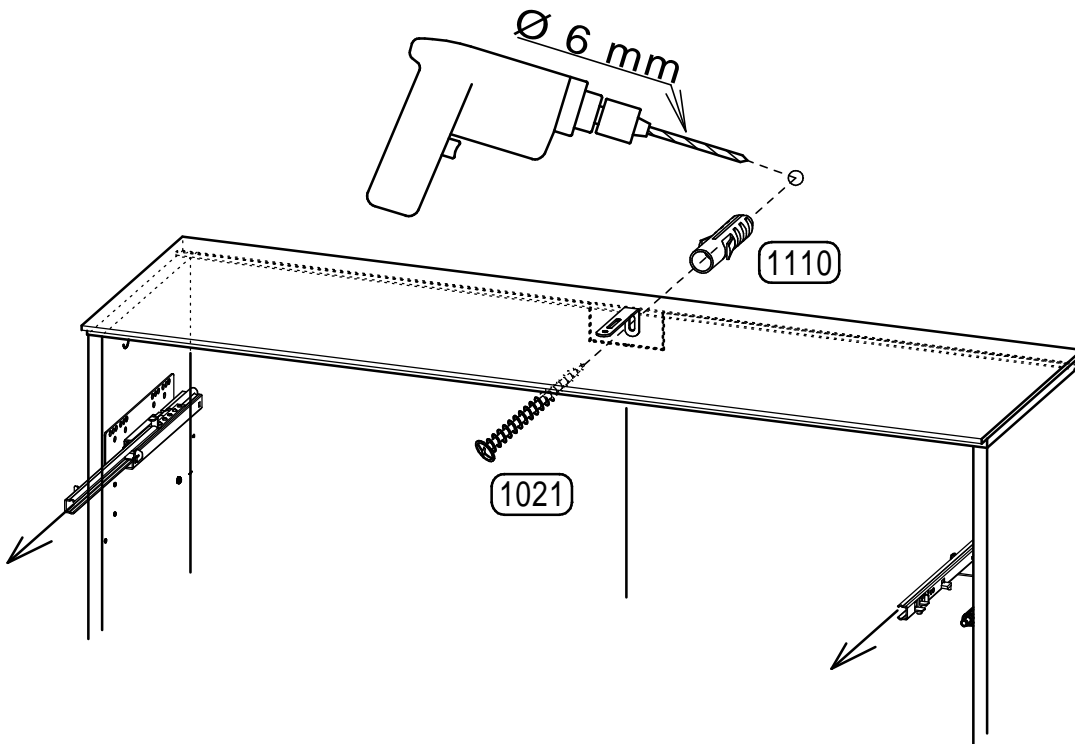

1110

1x



Ø6x30mm

1021

1x

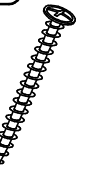

Ø4,5x40mm

9

erstellt

geändert

geprüft

Montageschritte - ordre de montage - assembly instructions

11. 11.2

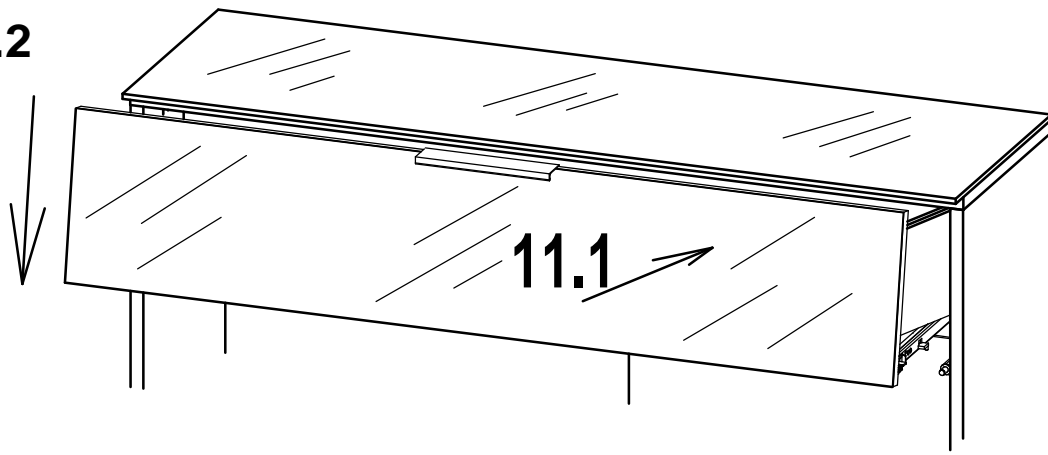

Montage - montage - assembly

Justierung - ajustment - adjustment

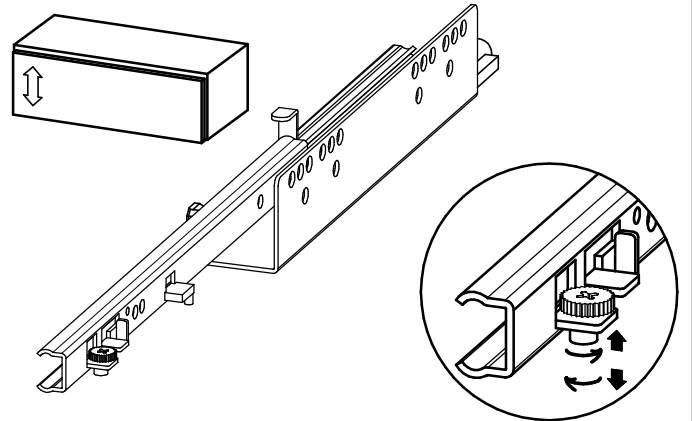
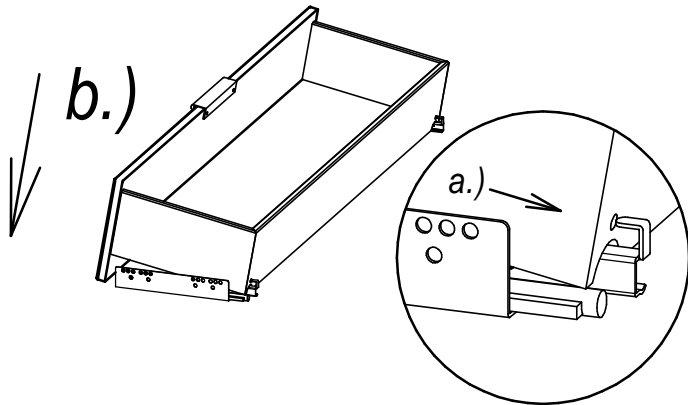

12.

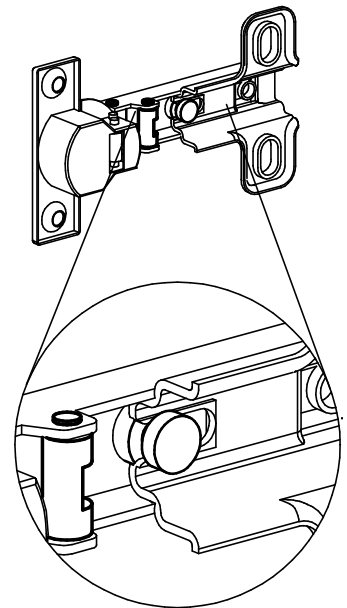
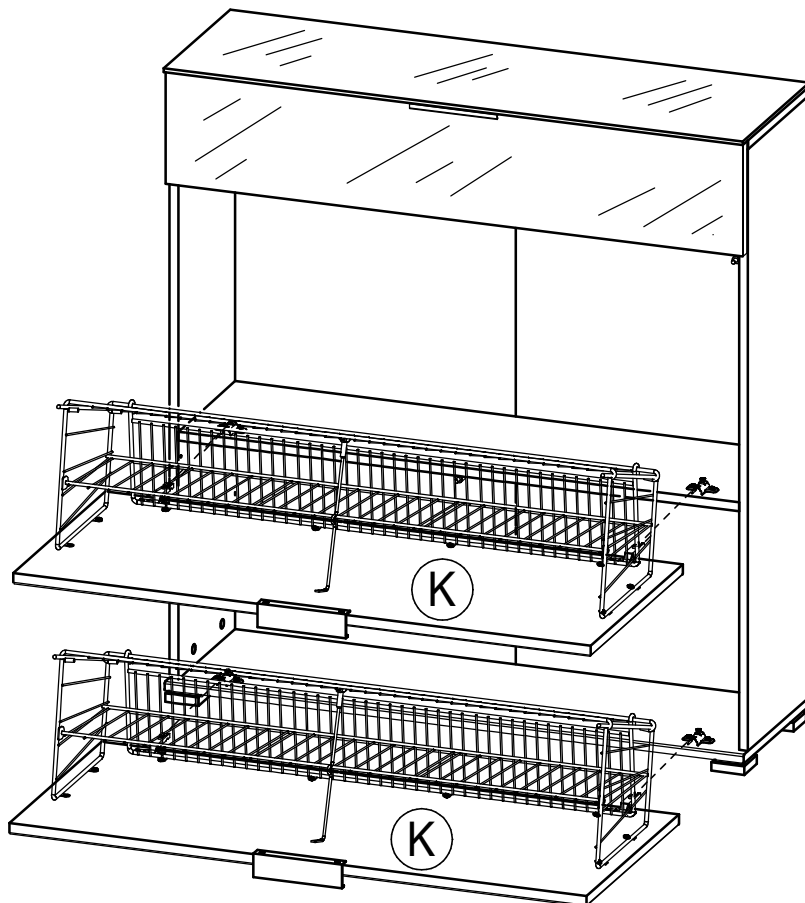

10

erstellt

geändert

geprüft

13.

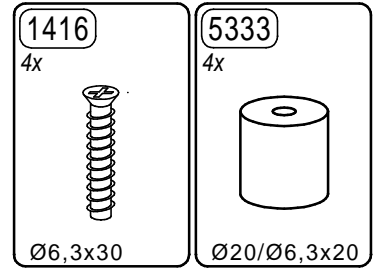

13.1

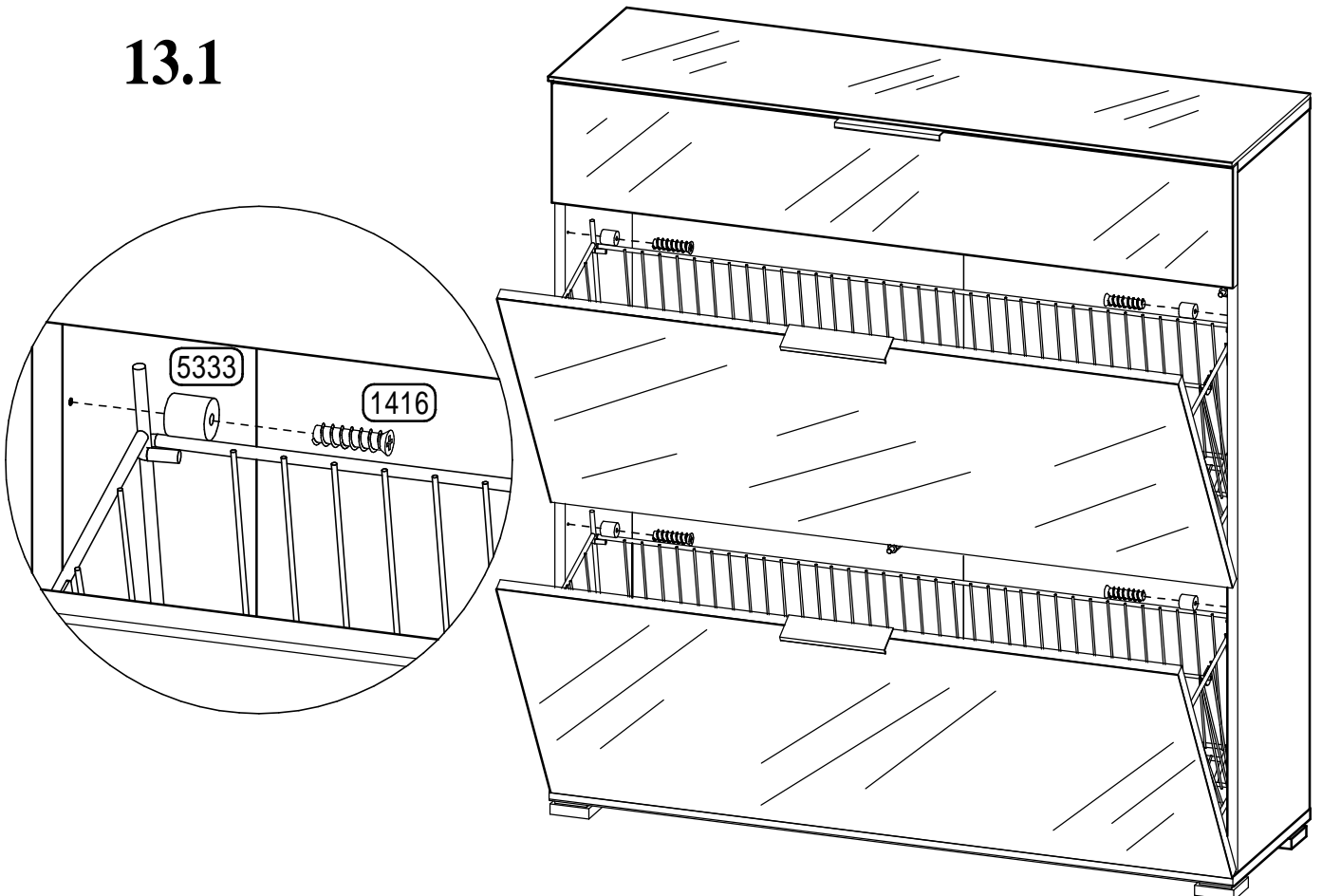

13.2

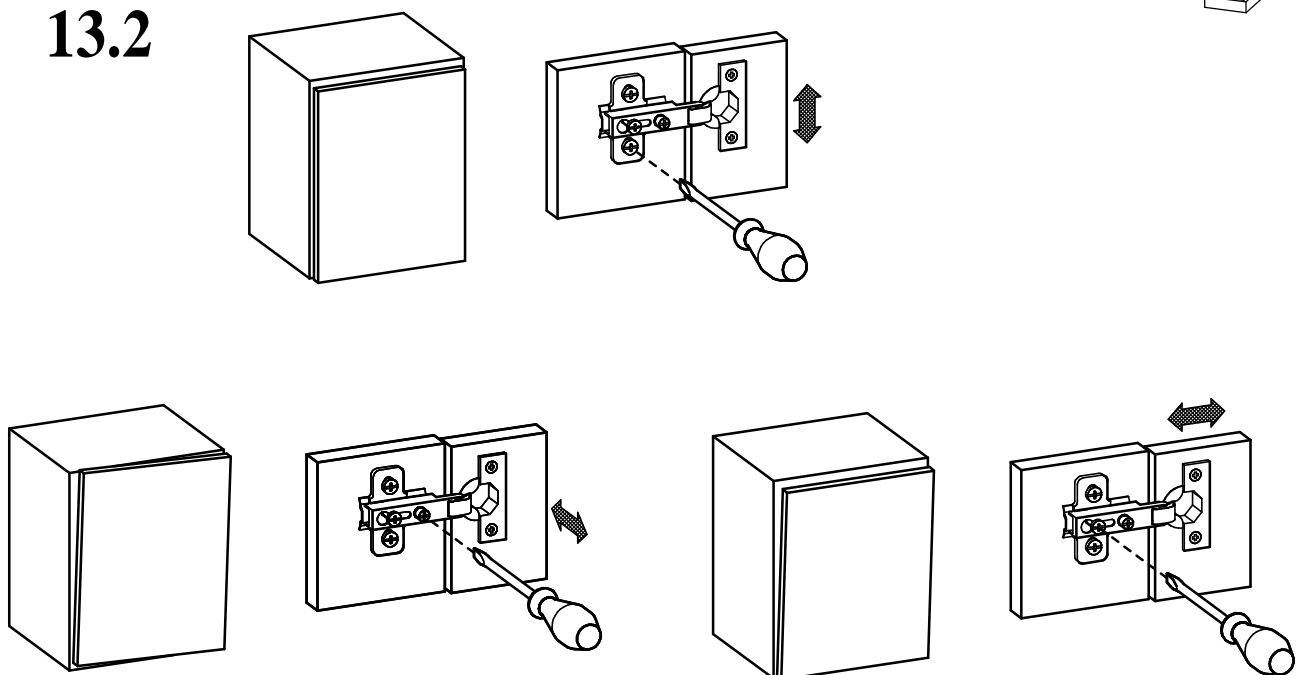

Ersatzteil-Direkt Service

(nur für Deutschland - for germany only - seulement pour Allemagne)

Sehr geehrter Kunde,
sollte ein Möbelteil bzw. Beschlagteil fehlen oder beschädigt sein, senden Sie uns den Artikel bitte **nicht** zurück, sondern fordern Sie der Einfachheit halber Ersatz direkt bei
Tragen Sie Ihren Bedarf in die Tabelle ein und übermitteln Sie uns diese Seite per Post, per Fax, telefonisch oder per e-mail.
Bitte unbedingt die MODELL-Nr. + DEKOR-Nr. (siehe Karton) und die entsprechende Teilebezeichnung (siehe Teileliste) angeben.



Mod. Nr.: _____ Dekor-Nr.: _____

Möbelteile

Teil	beschäd.	fehlt	Anzahl
Z	X		1

Beispiel

Beschlagteile

Teil	beschäd.	fehlt	Anzahl
		X	2

Beispiel

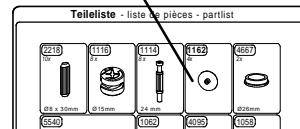
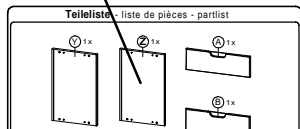

Absender nicht vergessen :

Name:	Strasse u. Nr.:		
PLZ:	Ort :		
Tel.:	Fax:	e-mail:	

Sicherheitshinweise Safety instructions Indications de sécurité



- 1.) Montageanleitung aufmerksam durchlesen
Please read assembly instruction carefully
Prière de bien lire la notice de montage du début à la fin
- 2.) Montage nach Montageanleitung durchführen
Please follow the assembly instruction step by step
Bien suivre le sens du montage indiqué sur la notice
- 3.) Montageanleitung aufbewahren
Please save the assembly instruction
Bien conserver la notice de montage



ACHTUNG! Beschlagbeutel und Beschlagteile von Säuglingen und Kindern fernhalten

ATTENTION! To avoid suffocation keep plastic bag away from children
Contains small parts which may be a choking hazard

ATTENTION! Toutes les pièces détachées livrées dans le colis être mis hors de portée des bébés des et enfants

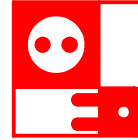

Netzanschluss (230V) nur von einem Fachmann ausführen lassen.
Sanitäranschluss nur von einem Fachmann ausführen lassen.
Mains connection (230V) has to be done by an expert.
Sanitary installation has to be done by an expert.
L'électricité (230V) uniquement à faire par un électricien.
Installation sanitaire à faire par un spécialiste.



Beiliegendes Befestigungsmaterial eignet sich nur für Massivwände.
Für andere Wände müssen Spezialdübel verwendet werden.
Die Festigkeit ist zu Prüfen.

The attached fixing materials is only suitable for solid walls.
For other Types of walls special dowels have to be used.
The firmness have to be checked.

Le matériel defixation ci-joint est exclusivement prévu pour des murs pleins(une fixation spéciale est nécessaire pour cloisons placo,...).
La fermeté est à examiner.

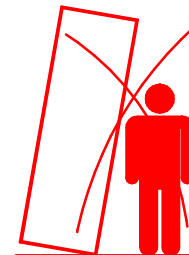

Beiliegende Wandbefestigungen dienen als Kippschutz, unbedingt anbringen!

The attached wall fixing is necessary to avoid tipping and must be fixed!

Les fixations prévues dans le colis préviennent contre le renversement du meuble. Il faut impérativement fixer le meuble au mur, afin d'éviter tout incident!

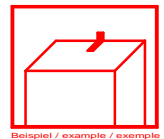

Beispiel / example / exemple

Für Schäden, die durch unsachgemäße Montage entstanden sind, übernehmen wir keine Haftung
For the damages, which have originatet prom improper assembly, we take over no liability.
Pour les dommages qui sont nés par le montage incorrect, nous ne prenons en charge aucune responsabilité.