







Assembly Instructions

ITEM NO.:11037

Thank you for purchasing this quality product. Be sure to check all packing material carefully for small parts that may have come loose inside the carton during shipment. (Note: Loosely thread all screws/bolts first. Once the item is assembled then completely tighten.)

PARTS LIST:				HARDWARE LIST:				
No.	Description	Sketch	Quantity	No.	Sketch	Description	Size	Quantity
1	Top table		1 pc	A		Allen Wrench	ø4*60mm	1 PC
				B		Bolt	ø8**38mm	8 PCS
				C		Lock Washer	ø8*13mm	8 PCS
2	Legs		4pcs	D		Flat Washer	ø8*19mm	8 PCS
				3	Bottom		1pc	

STEP 1:

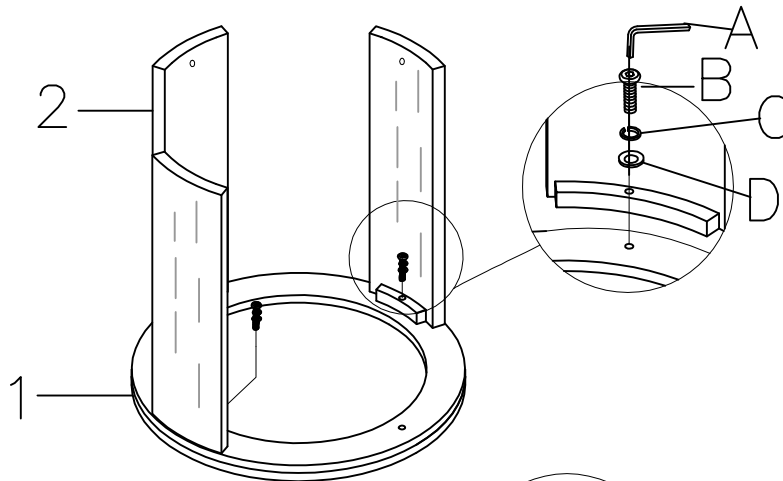

STEP 3:

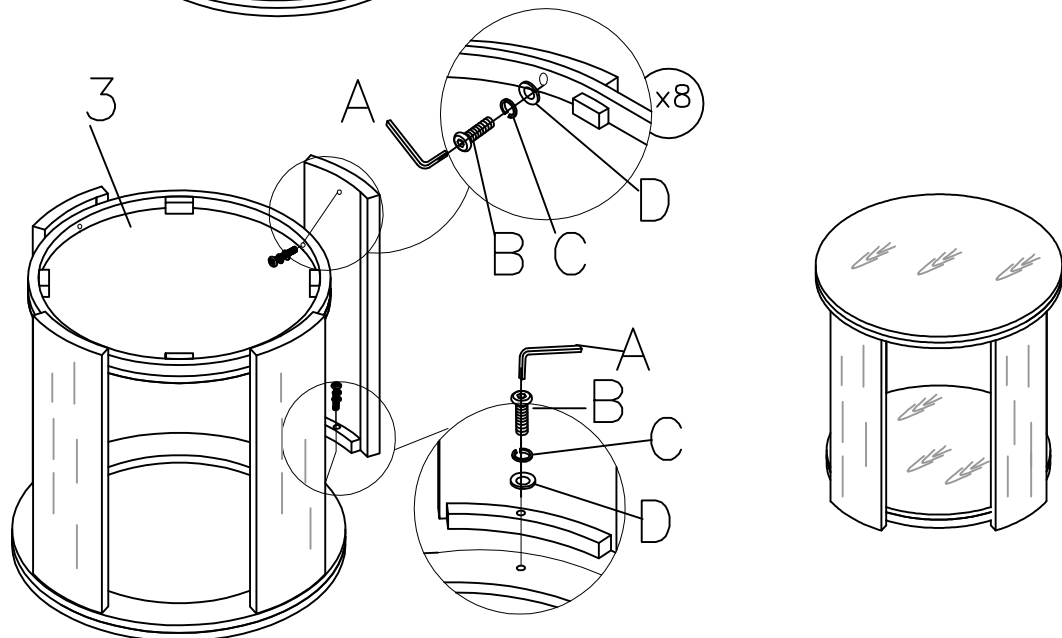

FINISH