

INSTRUCTIONS

Modular Sofa

CARTON A ASSEMBLY	PAGE 3
CARTON B ASSEMBLY	PAGE 10
CARTON C ASSEMBLY	PAGE 17
CARTON A + CARTON B ASSEMBLY	PAGE 19
MUTI-SEATER SOFA ASSEMBLY	PAGE 20

Limited Warranty

Products are warranted against defects in material and workmanship while owned by the " Original Purchaser". The term "Original Purchaser" is defined as that party or entity which purchases furniture from an authorized retailer as shown by the original sales receipt. This warranty does not apply to "as is" or previously owned seating products. We warrant its products to be free from defects in materials and workman-ship(normal wear and tear, fading and stretching excepted), for one year from the date of purchase, except as provided below under the limited warranty.

The exceptions or exclusions to this warranty are as follows:

- 1.Any warranty claim that is submitted after the limited warranty period, or without proper proof of purchase will not include the cost of parts, labor,or delivery.
- 2.This warranty shall not apply to the products which have been subjected to misuse, neglect, alteration, modification, or attachments,either caused by the original purchaser, shipping,storage, accident, fire, or acts of God.

In the event of a defect in material or workmanship covered by this warranty we will repair or replace, at their discretion, without charge the warranted furniture within a reasonable amount of time. We reserve the right to require damaged parts to be returned to us upon request, Natural markings such as cars, brands, grain variations, wrinkles, color variations, etc. will be considered normal characteristics and not construed as defects. We cannot warrant leather against scratching or scuffing, as all leather is subject to blemishes with use.

For claims or questions concerning this warranty, please contact customer Service department . Be prepared to provide your name, address, daytime phone number, the model and purchase order number of the product, date of purchase, and the store where it was purchased. Life fair requires that the original sales receipt be submitted with all requests to confirm that you are the original purchaser according to our written warranty.

This warranty gives you specific rights, and you may also have other rights,which vary from state to state.

NOTICE :

Please retain these instructions for future reference.

- Please read the instruction sheets completely before assembly. Remove all parts from carton and ensure all components included prior to assembly.
- Assemble the sofa on a protected surface to avoid scratching the components of sofa.
- Be careful not to cross-thread screws.
- Do not use power tools.
- Two people are recommended for assembly!
- According to the fabric characteristics of ottoman, please avoid direct-sun exposure.
- If the sofa is smelling, please try to air it for 24-48hours and the smell will go away.
- Sometimes it's because it was packed for a long time,so It's very normal to get that smell.
- Sofa is certified by the environment system. So please don't worry, it won't hurt your health, it's safe to use it.

RETURN/DAMAGE CLAIM INSTRUCTIONS:

- DO NOT discard of the box/original packaging. In case a return is required, the item must be returned in original box. Without this your return will not be accepted.
- Take a photo of the box markings. A photo of the markings (text)on the side of the box or instruction is required in case a part is needed for replacement. This helps our staff identify your product number to ensure you receive the correct parts.
- Take a photo of damage (if applicable). A photo of the damage is always required to file a claim and get your replacement or refund processed quickly. Please make sure you have the box even if it is damaged.
- Send us an email with the images requested. Email us directly from marketplace where your item was purchased with the attached images and a description of your claim.

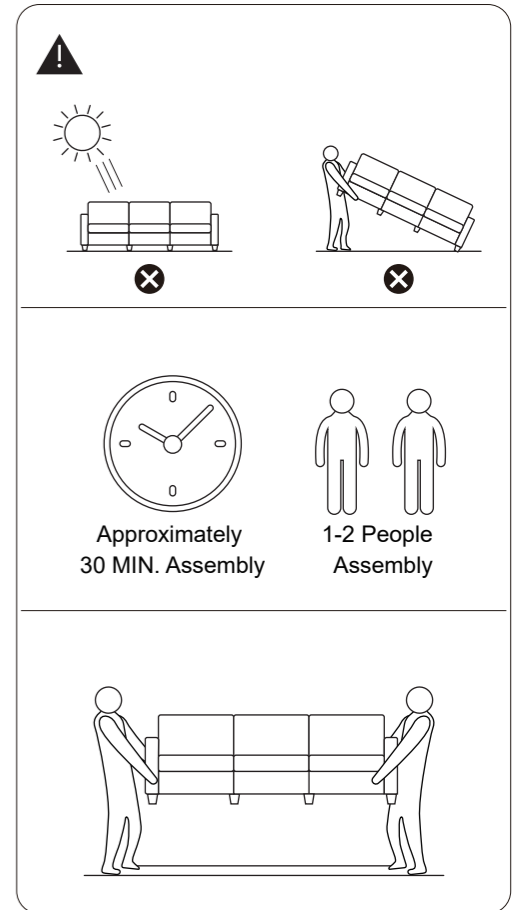

CARTON A PART LIST

A Right Armrest

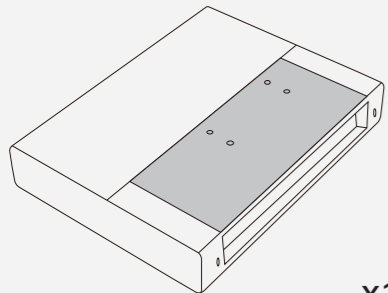

x1

B Left Armrest

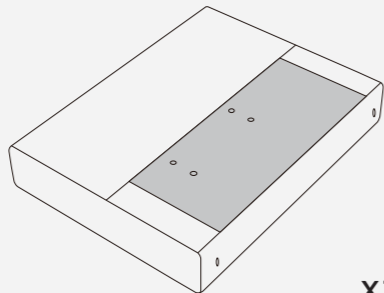

x1

C Plastic Leg

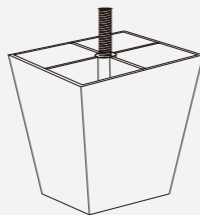

x4

1 Armrest & Backrest Fitting

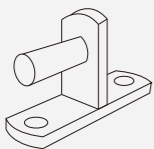

x4

2 Screw

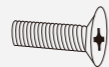

x8

3 Plastic Washer

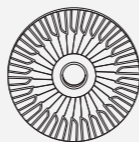

x4

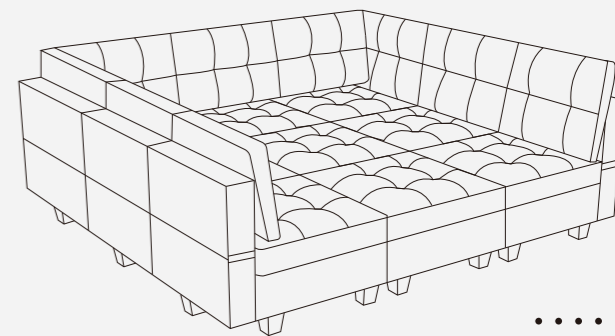
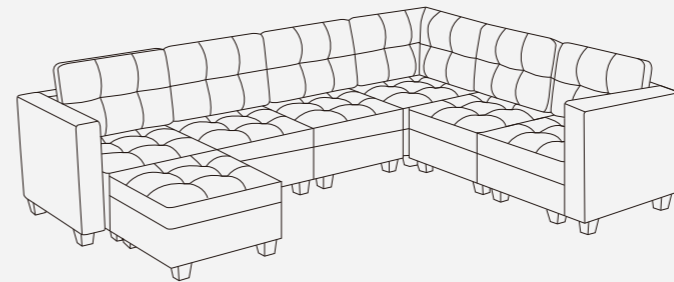
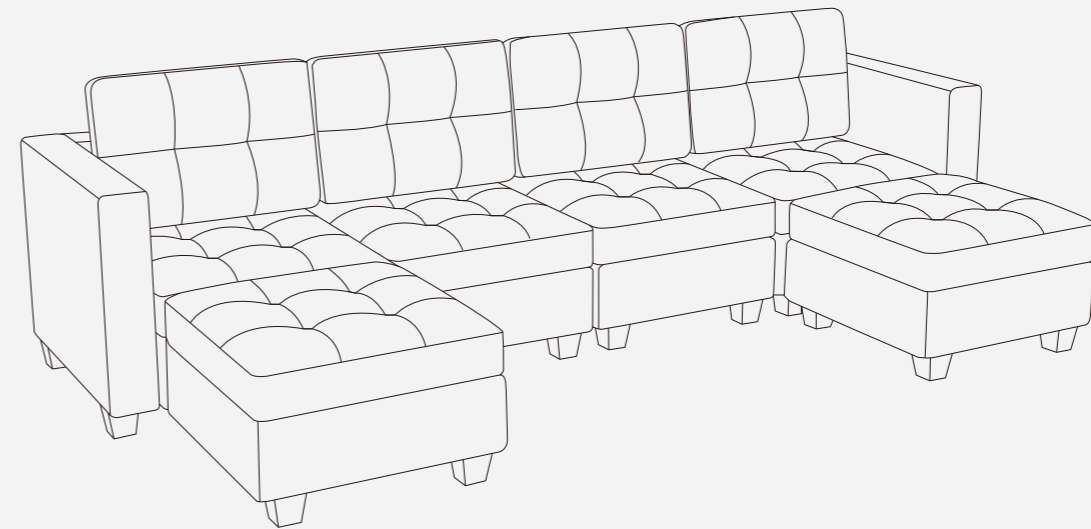

MULTI-SEATER SOFA ASSEMBLY

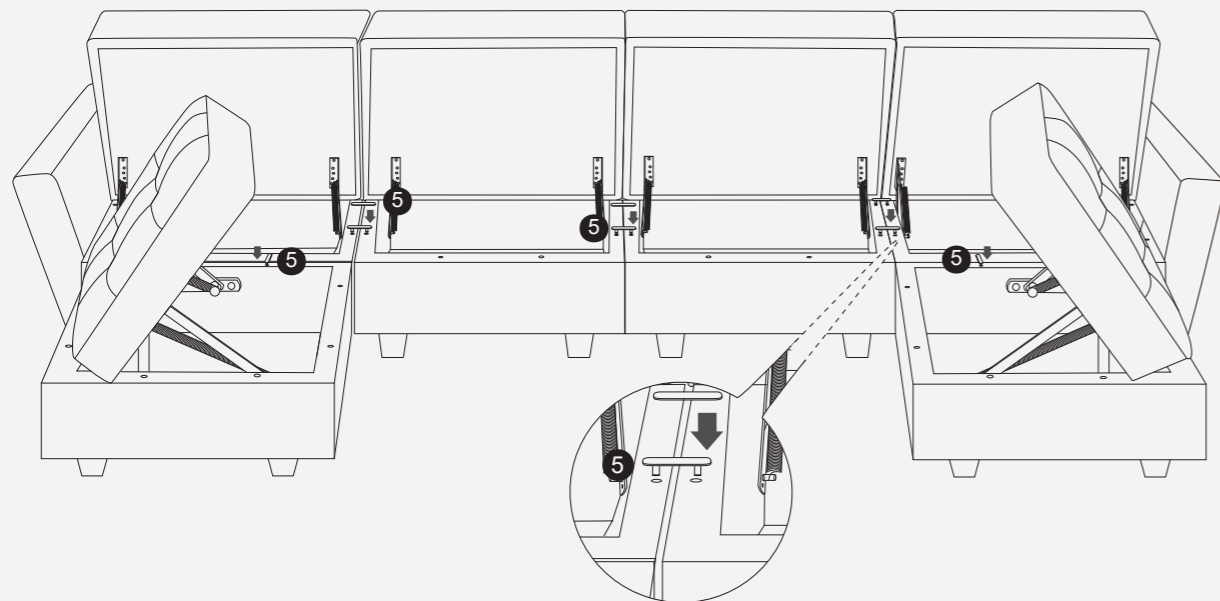

CARTON A ASSEMBLY

Step1:

Armrests are in carton A, Remove all parts from the carton A ,
Place them on protected surface or carpet.

Step2:

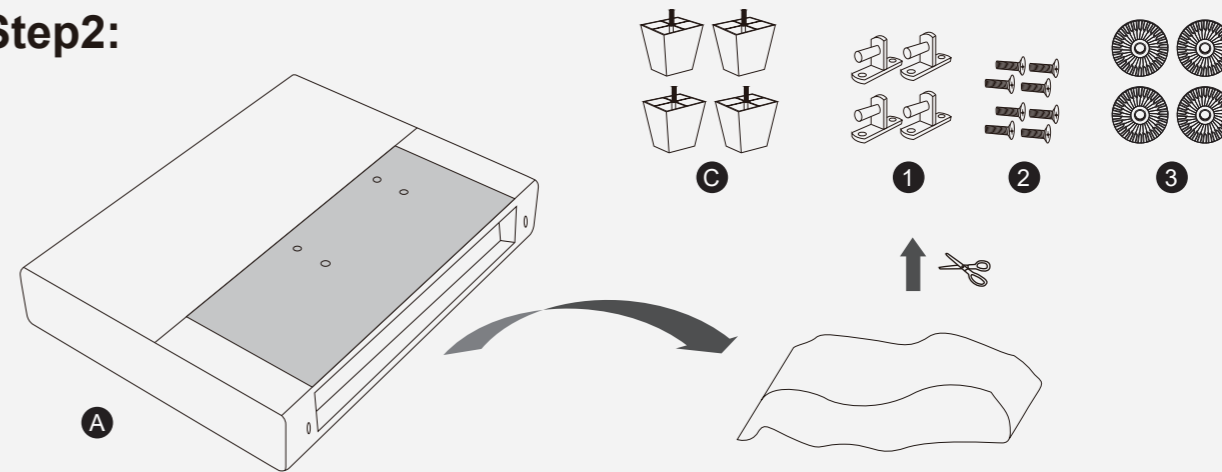

Step3:

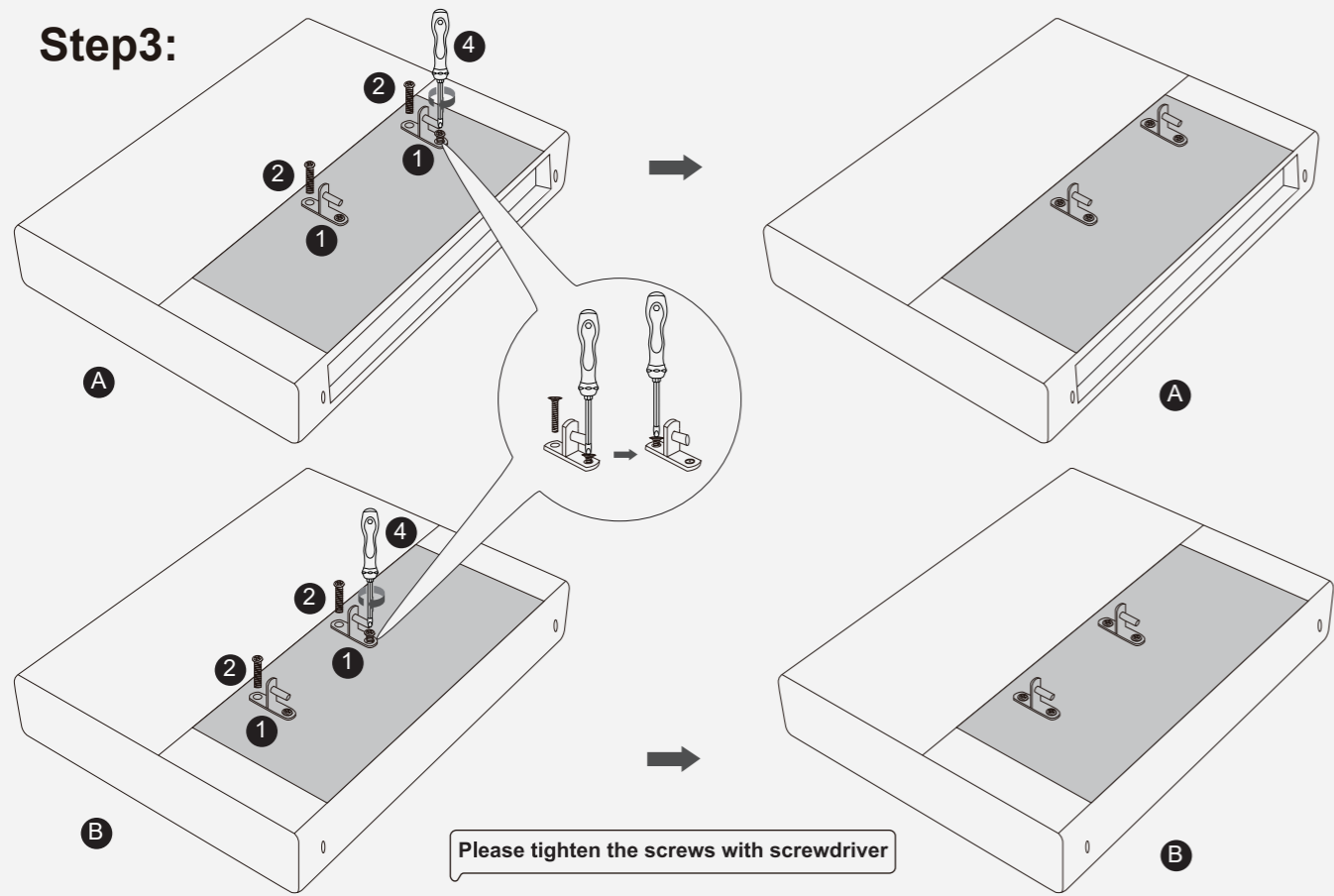

CARTON A + CARTON B

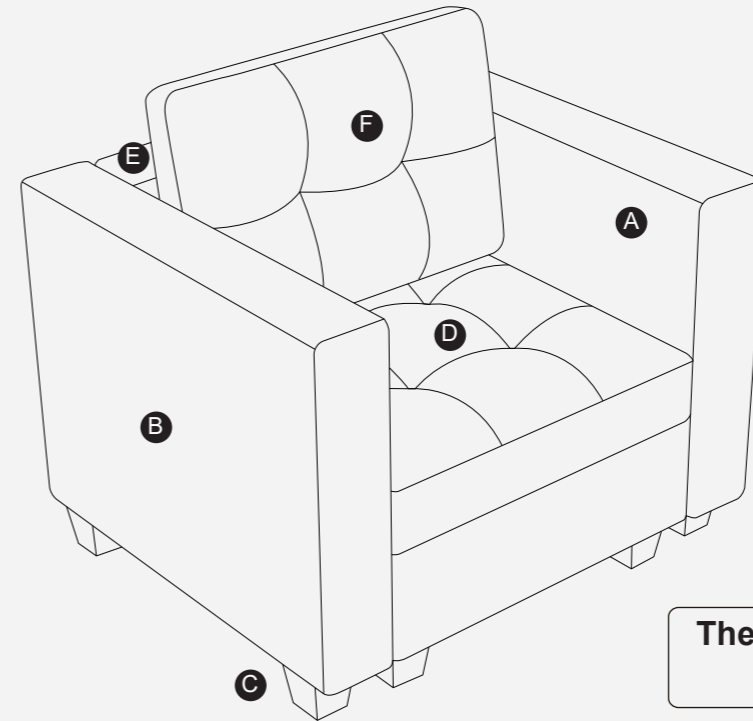

The single sofa chair is made up of 1*CartonA and 1*CartonB

Step4:

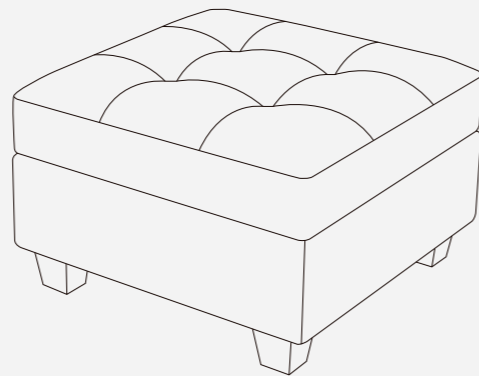
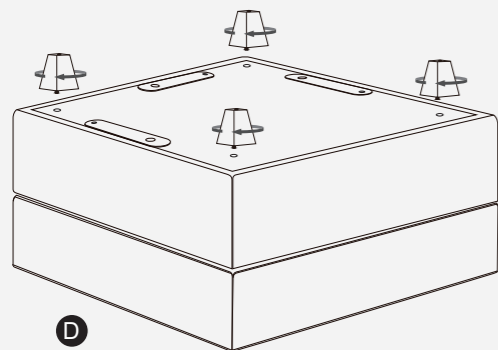
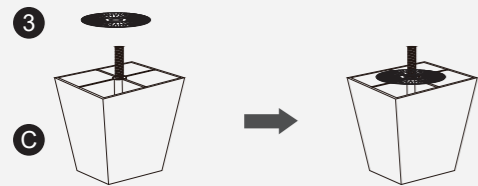

Step4:

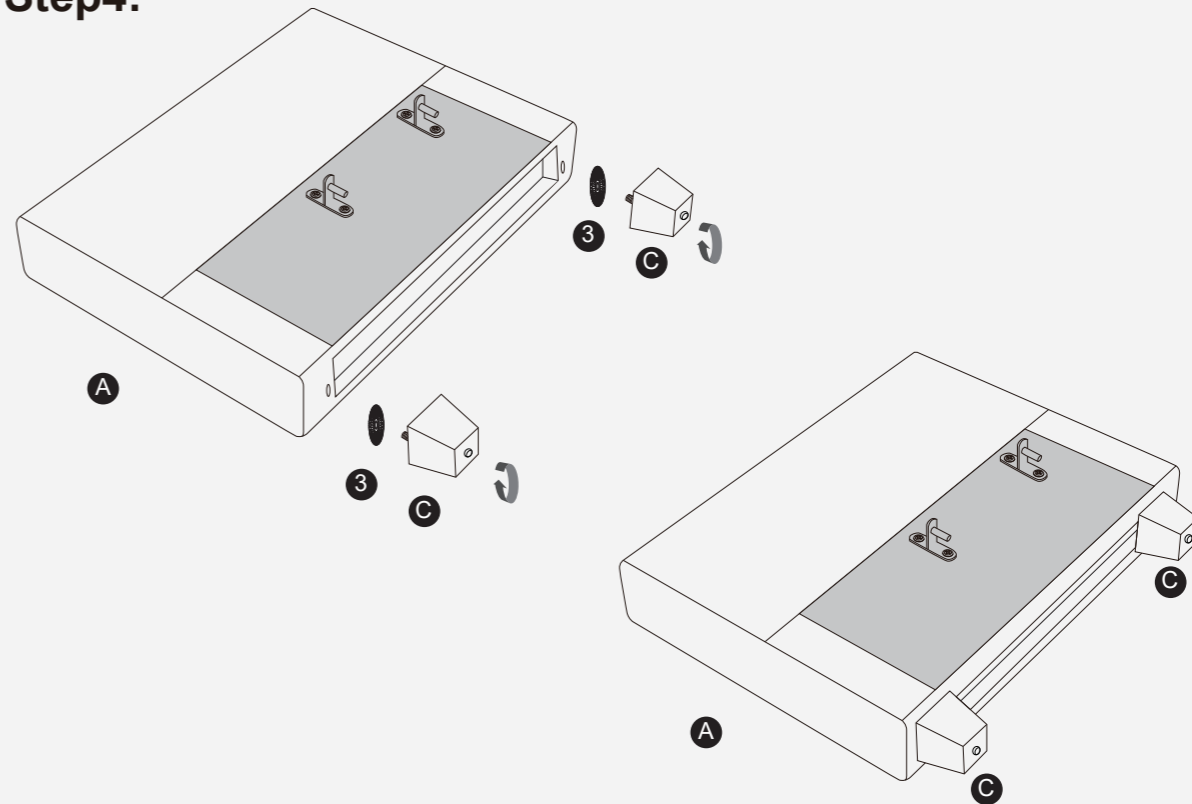

Step5:

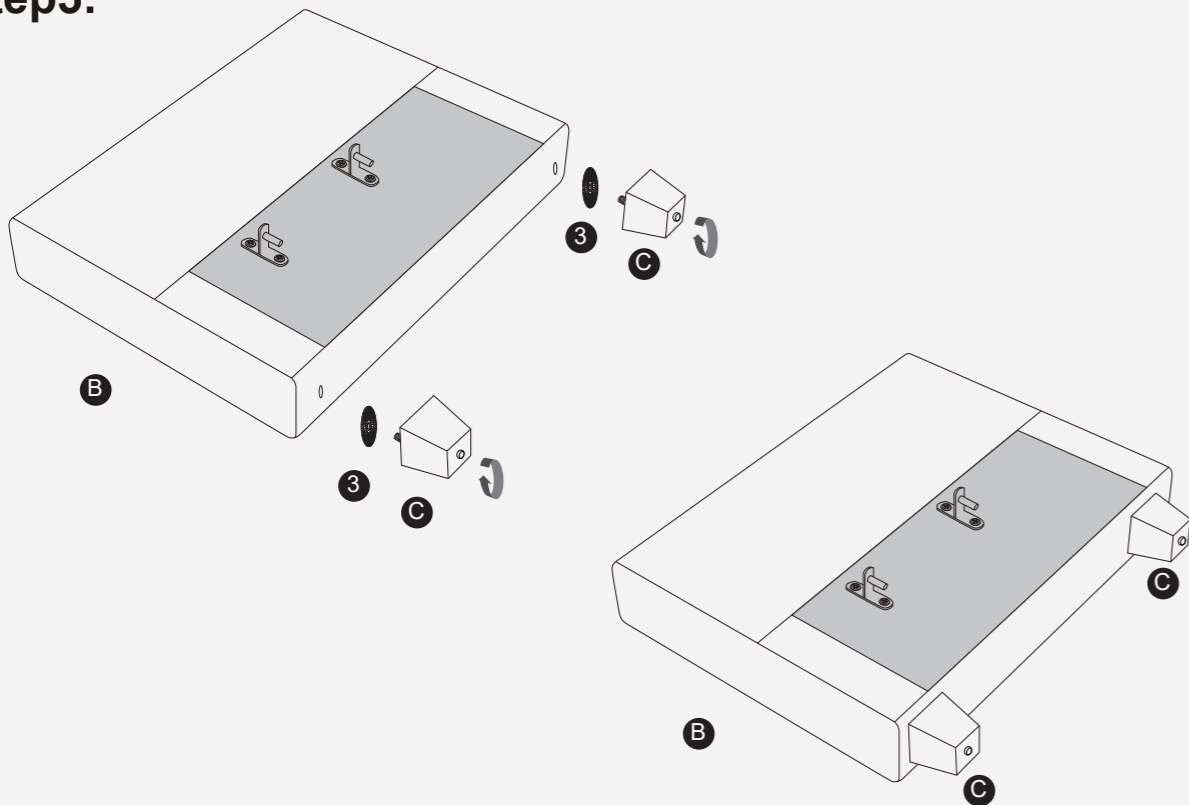

CARTON C ASSEMBLY

Step1:

Seat frame is in carton C ,Remove all parts from the carton C,Place them on protected surface or carpet.

Step2:

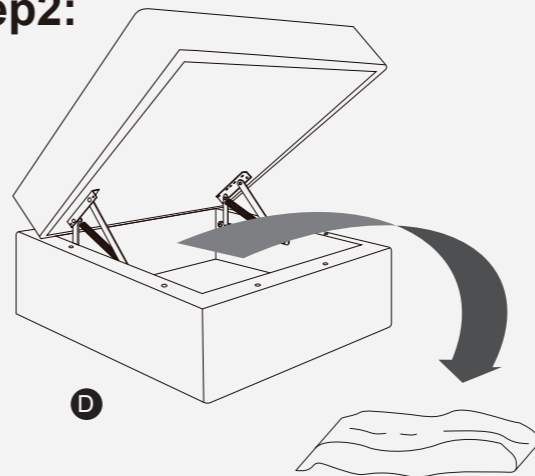

Step3:

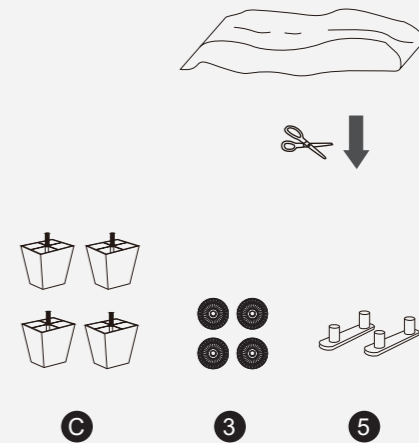

CARTON C PART LIST

D Single Seat Frame

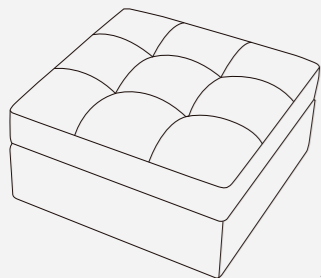

x1

C Plastic Leg

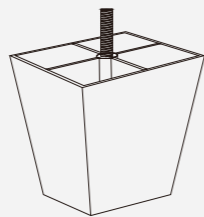

x4

3 Plastic Washer

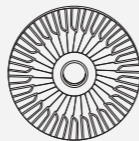

x4

5 Single Seat Fitting

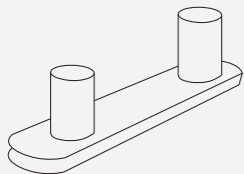

x2

Step6:

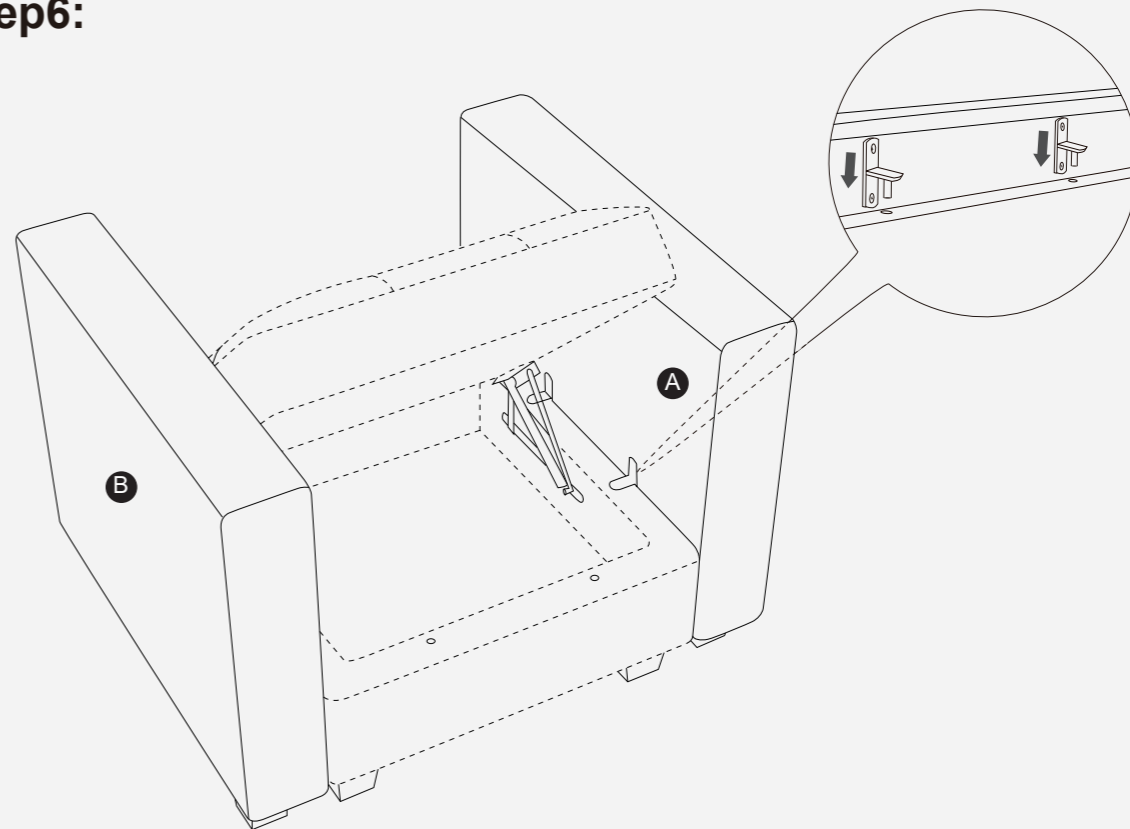

CARTON B PART LIST

D Single Seat Frame

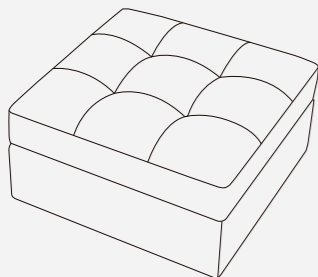

x1

E Backrest

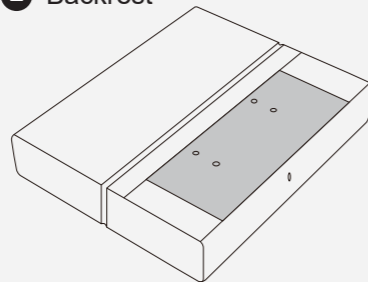

x1

F Pillow

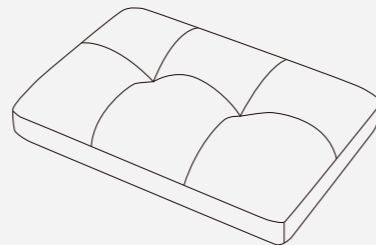

x1

C Plastic Leg

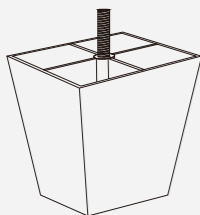

x5

1 Armrest & Backrest Fitting

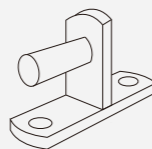

x2

2 Screw



x4

BACKREST ADJUSTMENT

The backrests are adjustable continuously by "pull "or "push".

To adjust the backrests, just pull it to dotted line position (as the picture shows) to get reset first then pull the back frame to the desired position.

Please note that the maximum angle of pulling is 135°.

You can push the backrest back directly and there is no need to get reset.

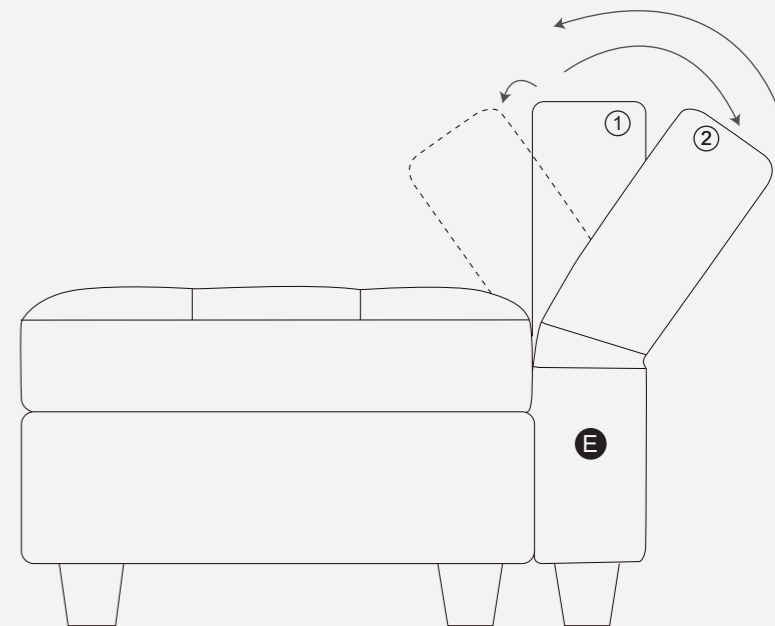

Step8:

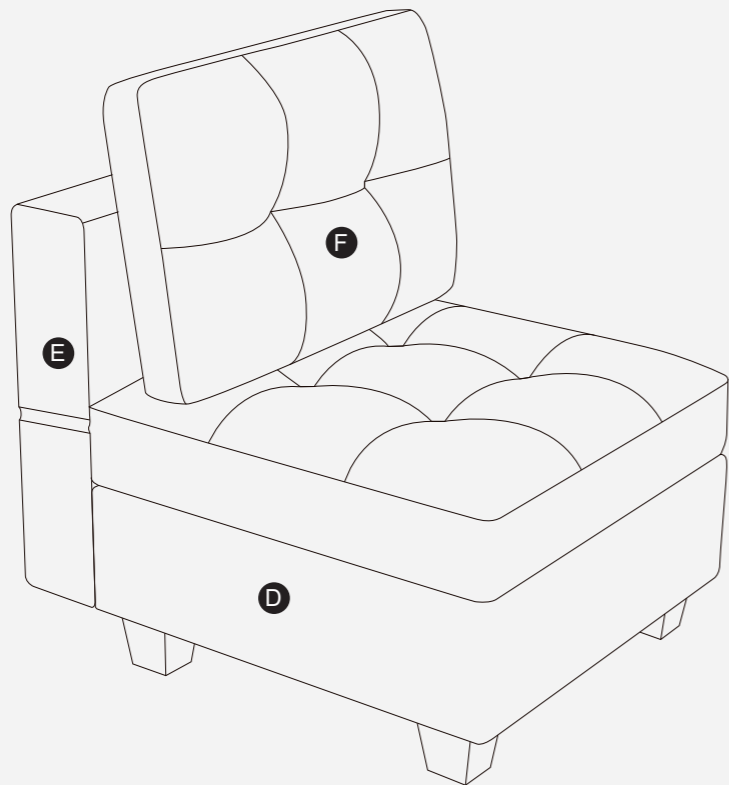

3 Plastic Washer

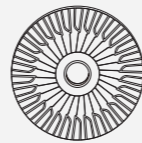

x5

4 Screwdriver



x1

5 Single Seat Fitting

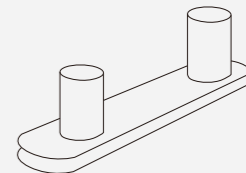

x2

6 Assembly Instructions



x1

Step5:

Please tighten the screws with screwdriver

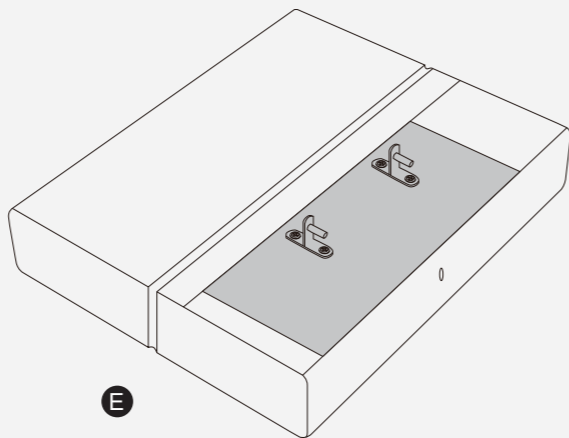
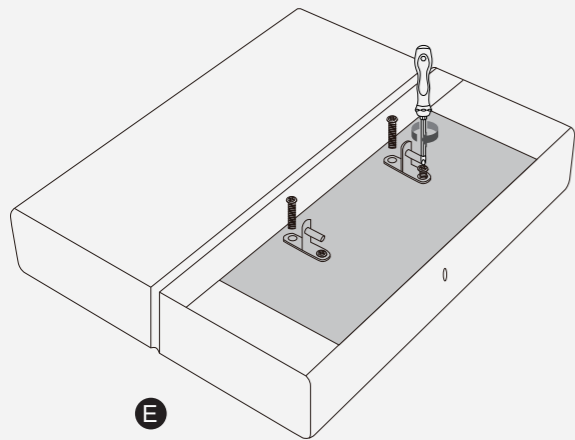

Step3:

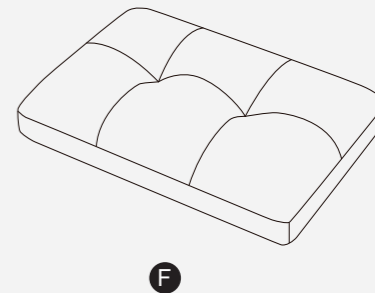
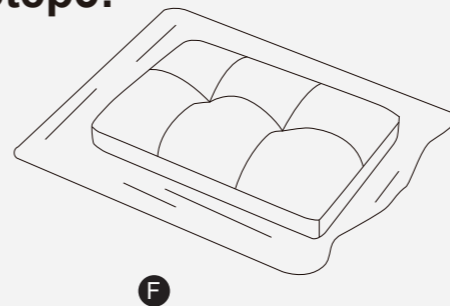

Step4:

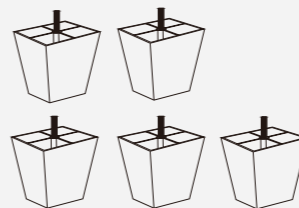

C



3

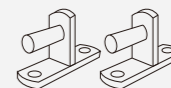

1



2

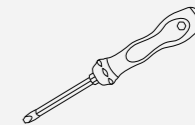

4

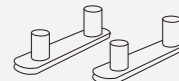

5