

# ASSEMBLY INSTRUCTION

## INSTRUCTIONS D'ASSEMBLEMENT

### ITEM NO: N752P342929







**ATTENTION:**

1. Check to ensure all parts and hardware are present.
- 2. We have provided Extra Hardware of A/B/C/D/E/F/H in case of any bolts missing in the boxes.**
3. Do not fully tighten all bolts until all parts are in place. Failure to follow these instructions may cause the bolt to misalign during assembly.

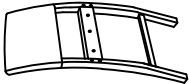







**ATTENTION:**

1. Vérifiez pour vous assurer que toutes les pièces et le matériel sont présents.
- 2. Nous fournissons du matériel supplémentaire pour A/B/C/D/E/F/H au cas où il manque des boulons dans la boîte.**
3. Ne serrez pas complètement tous les boulons jusqu'à ce que toutes les pièces soient en place. Le non - respect de ces instructions peut entraîner des dommages au boulon  
Dislocation lors de l'assemblage.

### Part List

|  |  |   |  |
|--|--|---|--|
| 1<br>   | 2<br>   | 3<br>   | 4<br> |
| Chair Back x 1pc   | Seat Cushion x 1pc   | Front Leg x 1pc   | Front Leg x 1pc  |
| 5<br> | 6<br> | 7<br> |  |
| Side Stretcher x 1pc   | Back Stretcher x 1pc   | Side Stretcher x 1pc  |  |

### Hardware

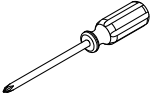
|  |  |  |  |  |
|--|--|--|--|--|
| A<br> | B<br> | C<br> | D<br> | E<br> |
| Ø10*30mm   | Ø1/4x38mm  | Ø1/4x60mm  | Ø1/4x75mm  | Ø1/4x13mm  |
| WOOD DOWEL<br>(1PC+1)  | SHORT BOLT<br>(2PCS+1)   | BOLT (4PCS+1)  | LONG BOLT<br>(4PCS+1)  | LOCK WASHER<br>(10PCS+1)   |
| F<br> | G<br> | H<br> | I<br> |  |
| Ø1/4x19x2mm  | 4mm  | Ø4x45mm  |  |  |
| FLAT WASHER<br>(10PCS+1)   | ALLEN KEY (1PC)  | SCREW (6PCS +1)  | SCREW DRIVER<br>(1PC)  |  |

STEP1 /Étape 1:

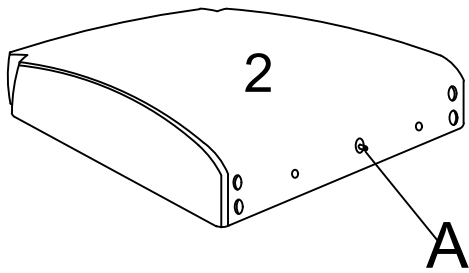

A x1PC

STEP2 /Étape 2:

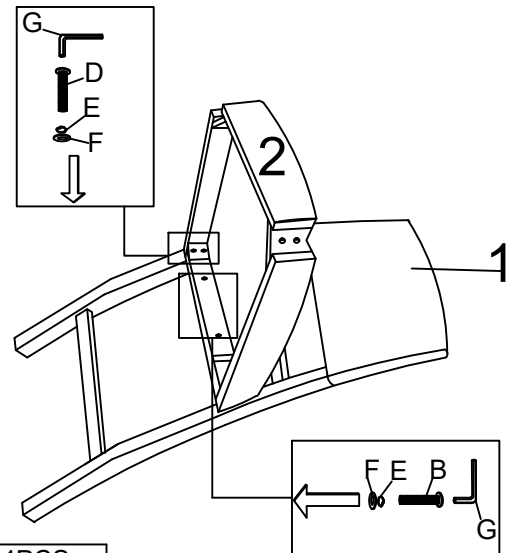

B x2PCS    D x4PCS

E x2PCS    E x4PCS

F x2PCS    F x4PCS

STEP3 /Étape 3:

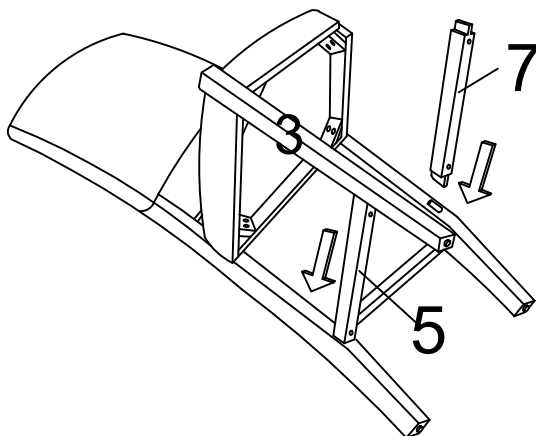

STEP4 /Étape 4:

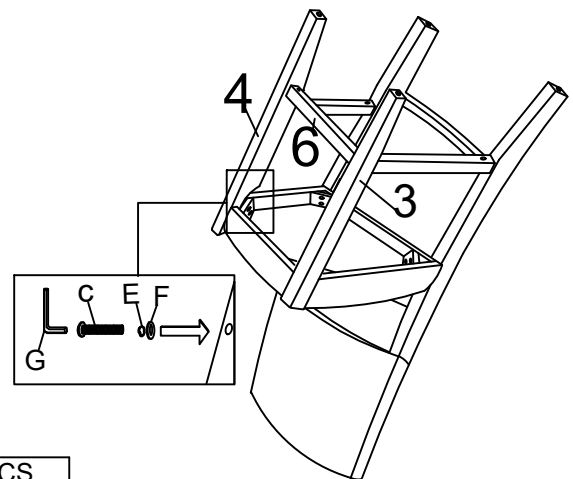

C x4PCS

F x4PCS

E x4PCS

STEP5 /Étape 5:

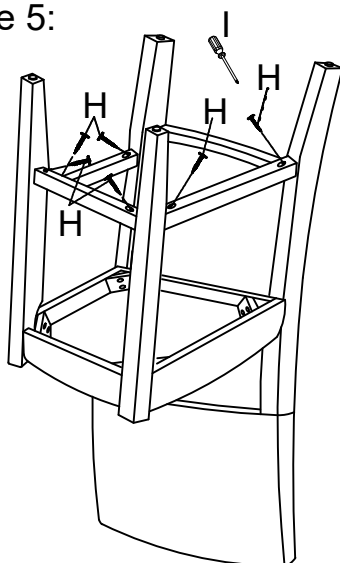

H x6PCS

I x1PCS

