

Corner Sofa*2

If you have any questions about the product, please feel free to contact us.

E-Mail: Patiofurniture Serviceteam@outlook.com

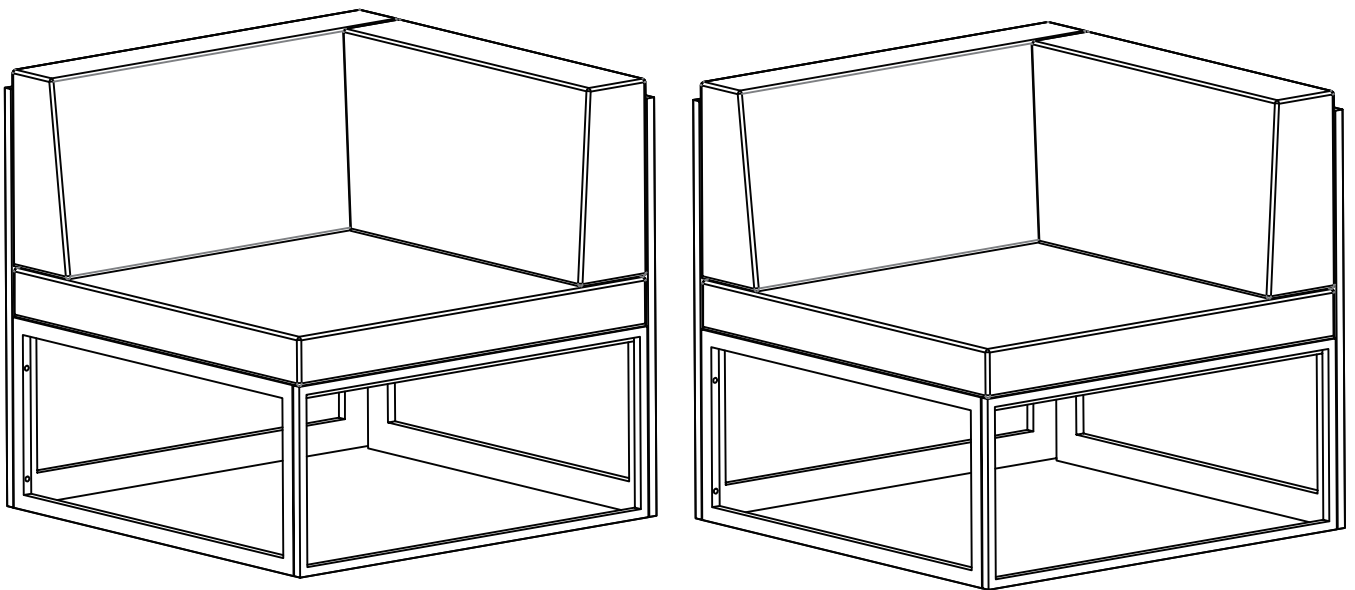

After-sales mailbox:
Patiofurniture Serviceteam@outlook.com

NOTICE



Please keep these instructions for future reference.

Dear Customer

● Thank you for your purchase. When you receive the product, please make sure that all the parts are intact. Then follow the entire installation instructions to install!

● **When installing, please be careful not to tighten the screws immediately! You need to make sure that all the screws are secured to 80%, then tighten them!**

A . The outer box is damaged

B . The product is damaged / bent / cracked while you open the box

C . The parts / accessories / assembly tools are missing

D . The instructions are not clear and can not be referred

E . The product has functional problems

F . Other aspects that you are not satisfied with

Please feel free to contact us for help. Our after-sales team service (Patiofurnitureser-vice@outlook.com) will reply within 24 hours and will do our best to resolve the problem for you.





Please feel free to contact us for help, and provide the following information:Platform/Shop name/Order ID/buyer's name/ receiver's address/Problem description.

o



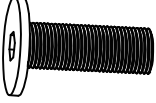
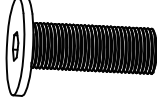
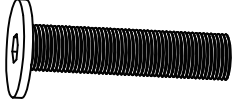
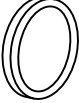

Please keep the original boxes for returns, refunds will be refused for other boxes. Check the integrity of the components and handle them gently during installation!

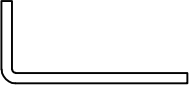
HARDWARE LIST

 <p>S1</p> <p>M6x25</p>	 <p>S2</p> <p>M6x35</p>	 <p>S3</p> <p>M6x60</p>	 <p>S4</p>	 <p>S5</p> <p>Screw head cover</p>
<p>16 pcs</p>	<p>12 pcs</p>	<p>4 pcs</p>	<p>32 pcs</p>	<p>32 pcs</p>
 <p>S6</p>	 <p>E1</p> <p>Waterproof Cover</p>	 <p>T</p>		
<p>8 pcs</p>	<p>2 pcs</p>	<p>1 pc</p>		

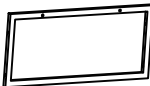
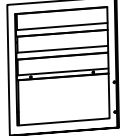
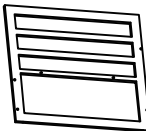
PART LIST

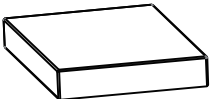
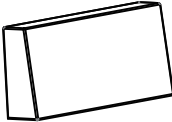
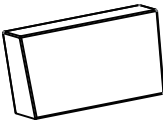
 <p>C1</p> <p>Front side piece</p>	 <p>B2</p> <p>Right side piece</p>	 <p>C3</p> <p>Left back</p>	 <p>C4</p> <p>Back</p>	 <p>C5</p> <p>Seat</p>
<p>2 pcs</p>	<p>2 pcs</p>	<p>2 pcs</p>	<p>2 pcs</p>	<p>2 pcs</p>
 <p>A4</p> <p>Cushion</p>	 <p>A5</p> <p>Big backing</p>	 <p>A6</p> <p>Small backing</p>		
<p>2 pcs</p>	<p>2 pcs</p>	<p>2 pcs</p>		

1. Please ensure that all accessories are complete before starting the installation.
2. Due to the variety of accessories, many accessories may be glued together, please check carefully
3. If any accessories are missing or damaged, please contact the seller immediately.

E-Mail: Patiofurniture Serviceteam@outlook.com

STEP 1

NOTICE

When installing, please be careful not to tighten the screws immediately!
You need to make sure that all the screws are secured to 80%, then tighten them!

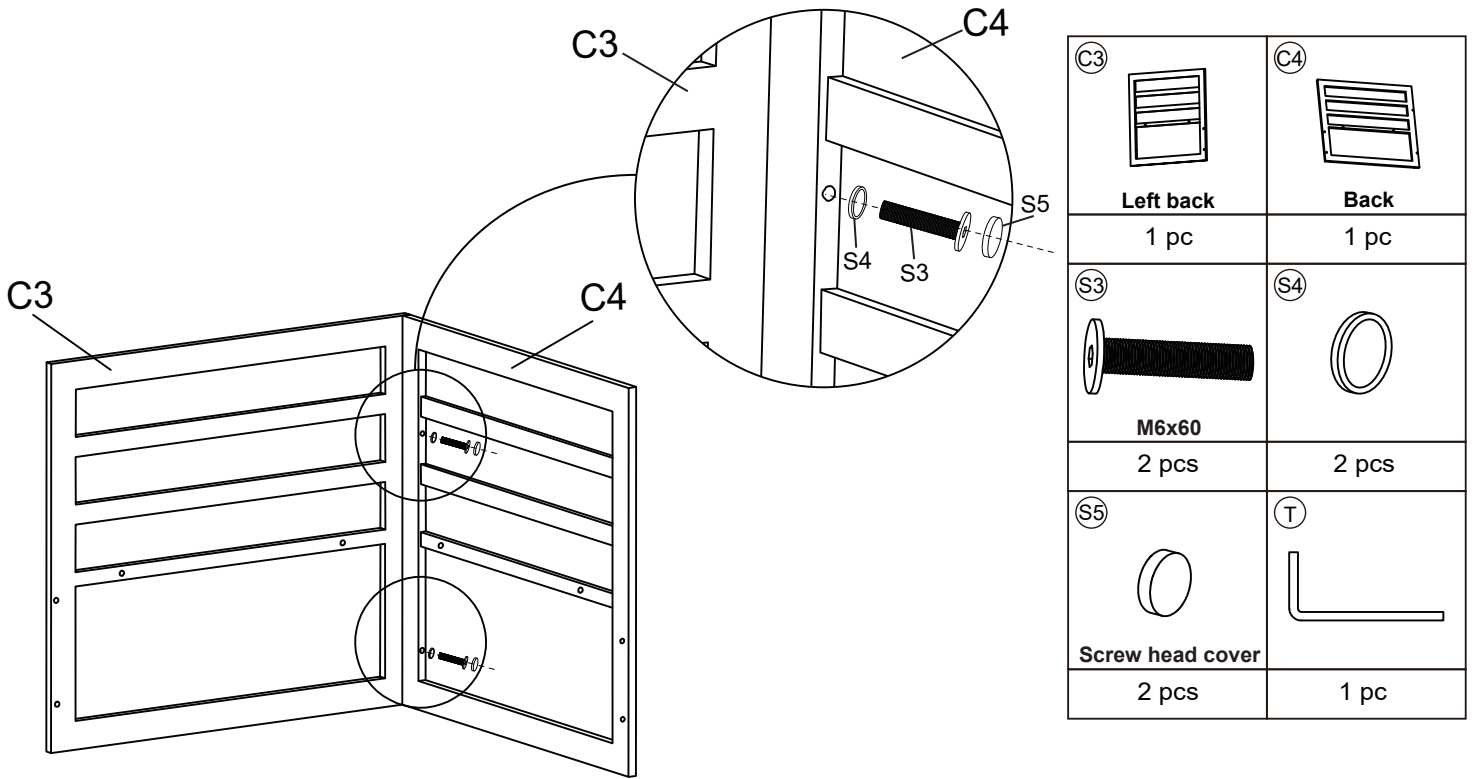



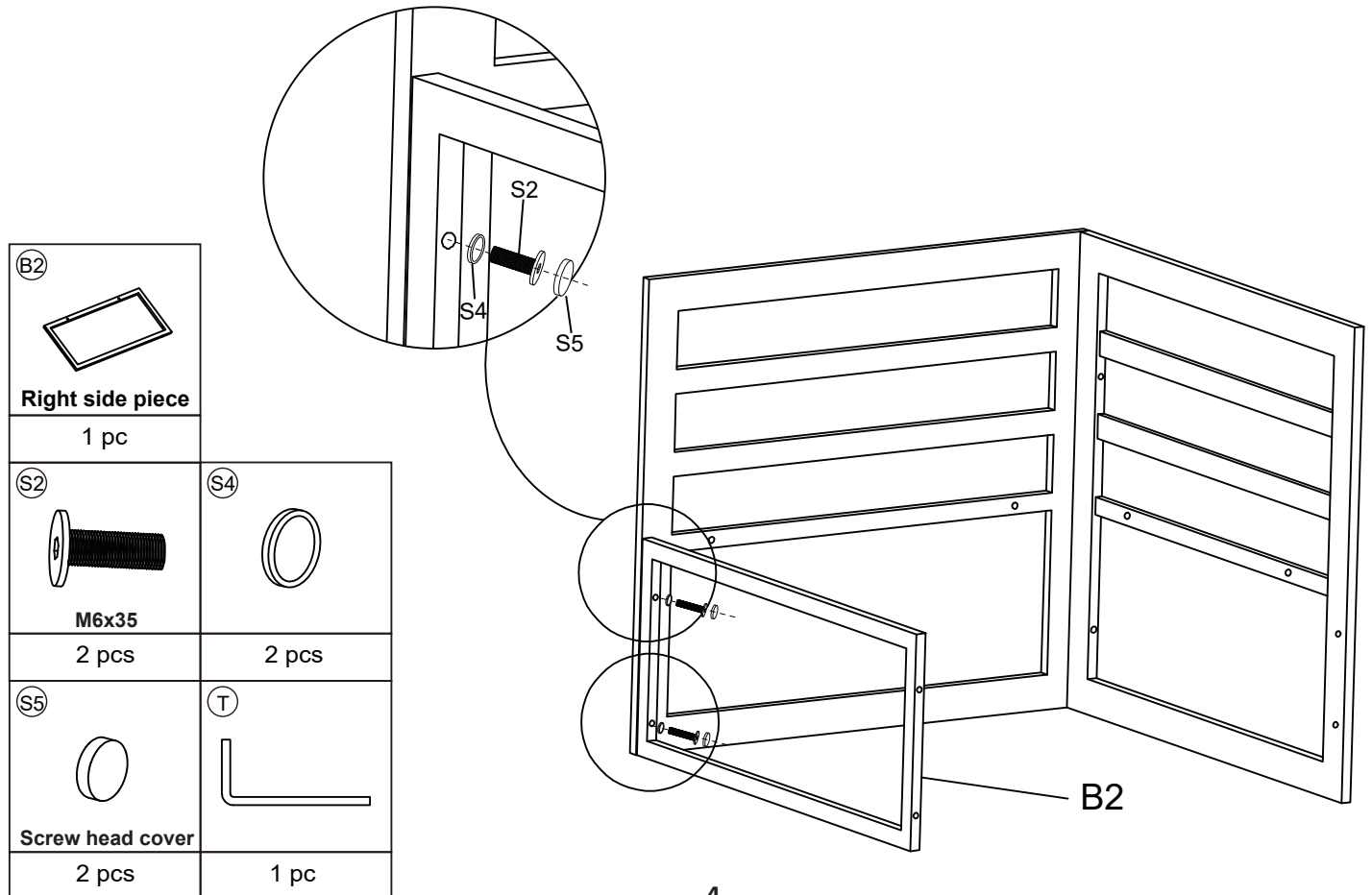

STEP 2

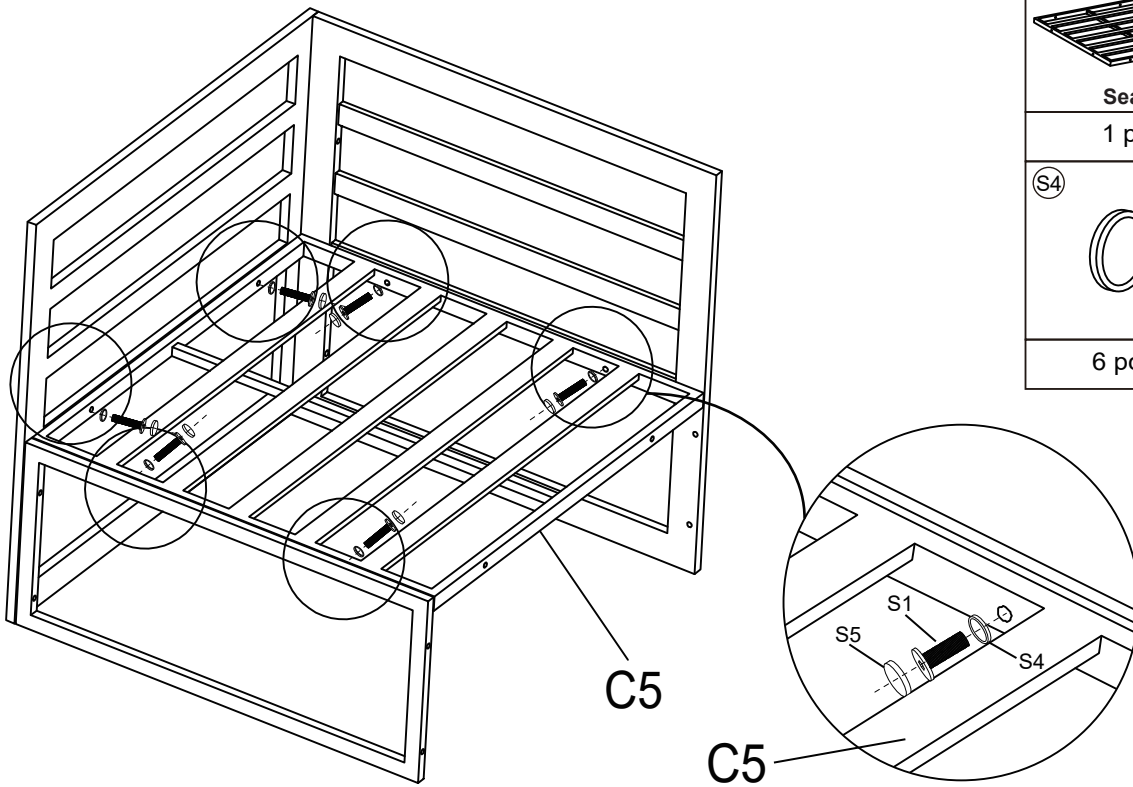

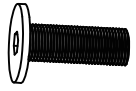





STEP 3

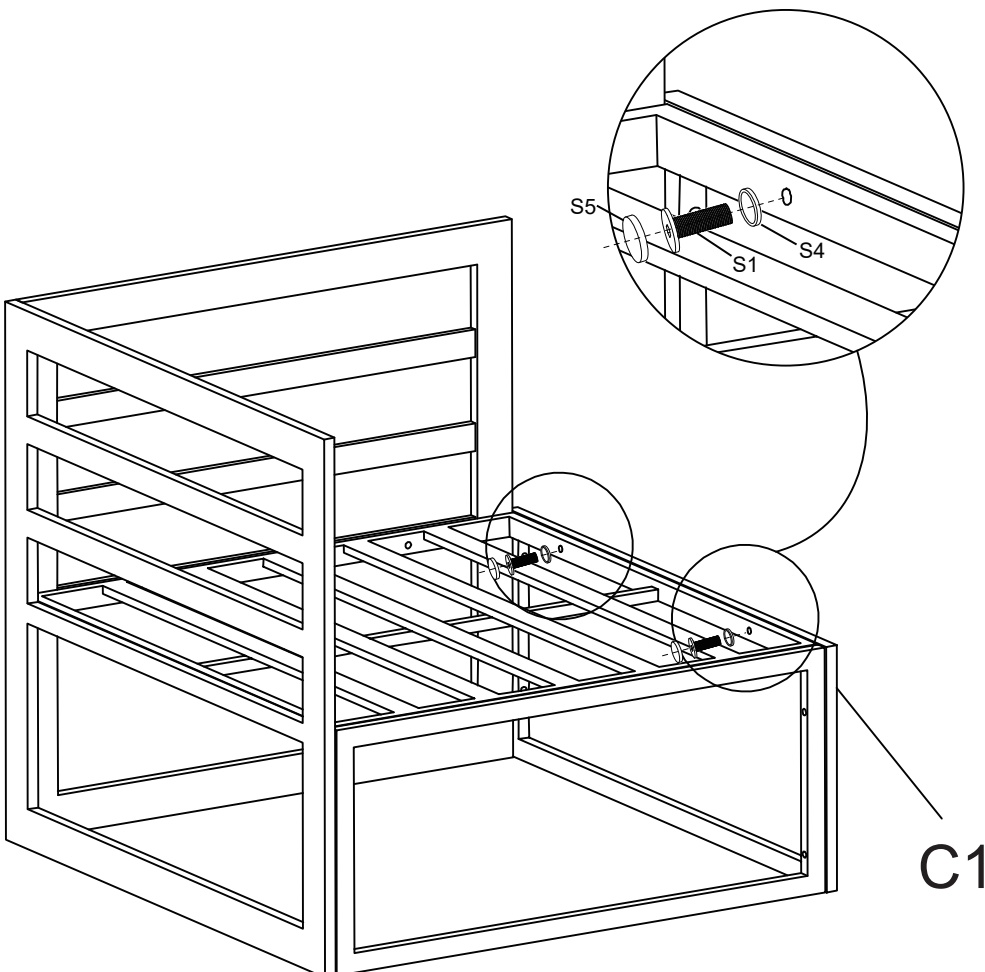

(C5)  Seat	(S1)  M6x25
1 pc	6 pcs
(S4) 	(S5)  Screw head cover
6 pcs	6 pcs
(T) 	
1 pc	

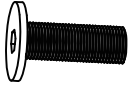

STEP 4

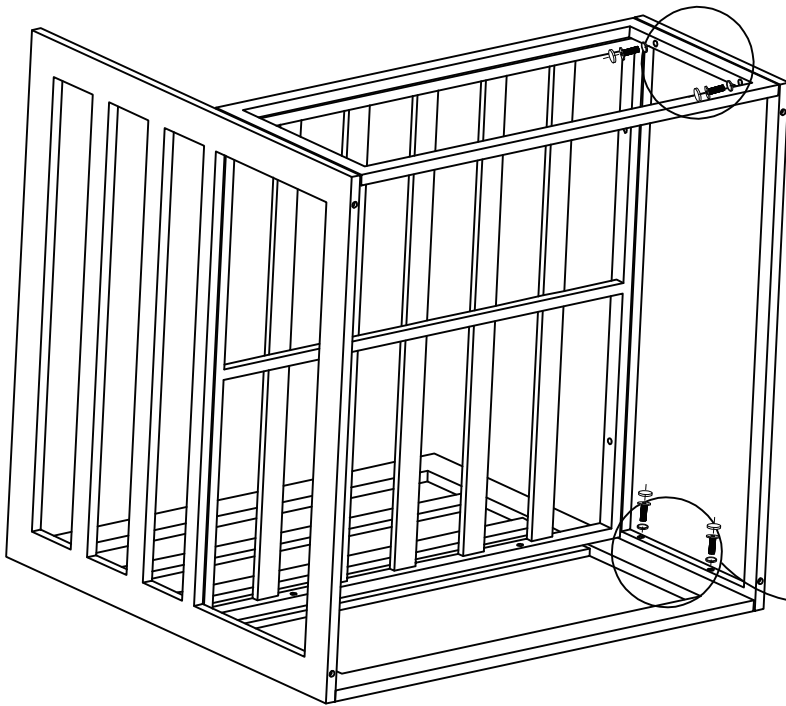

(C1)  Front side piece	(S1)  M6x25
1 pc	2 pcs
(S4) 	(S5)  Screw head cover
2 pcs	2 pcs
(T) 	
1 pc	

STEP 5

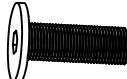

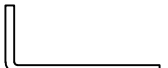
S2  M6x35 4 pcs	S4  4 pcs
S5  Screw head cover 4 pcs	T  1 pc

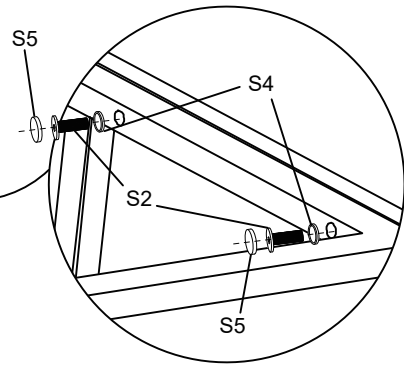

STEP 6

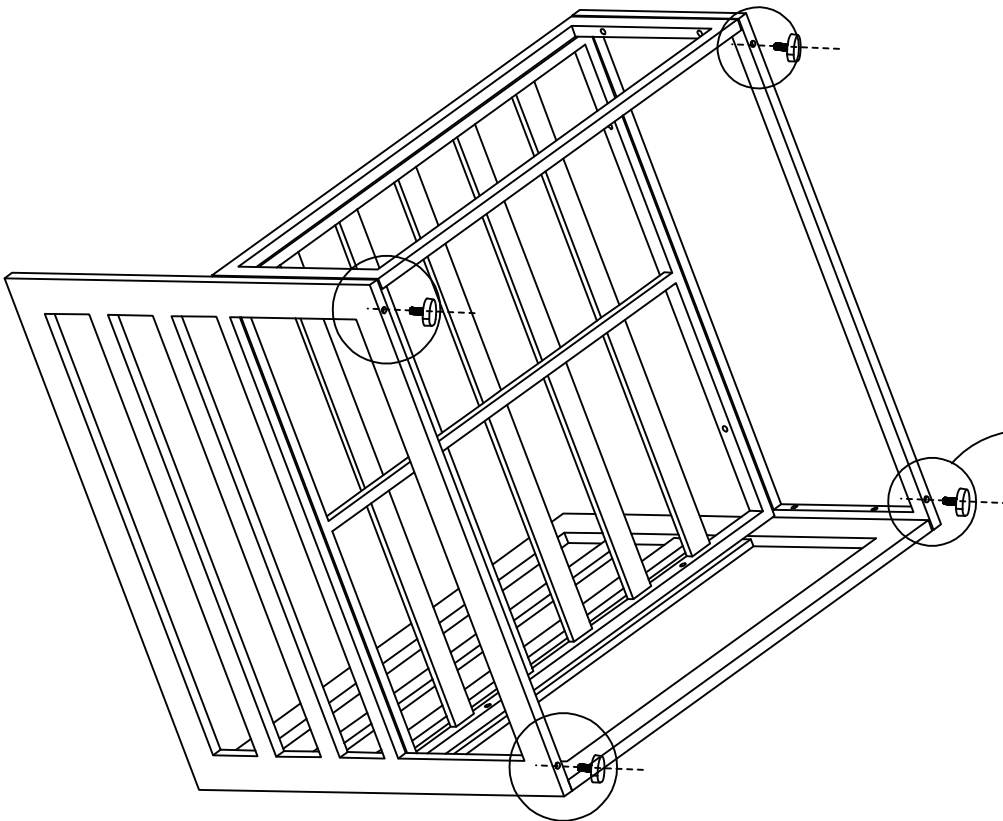

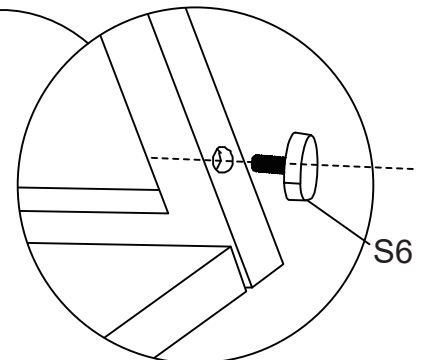

S6  4 pcs



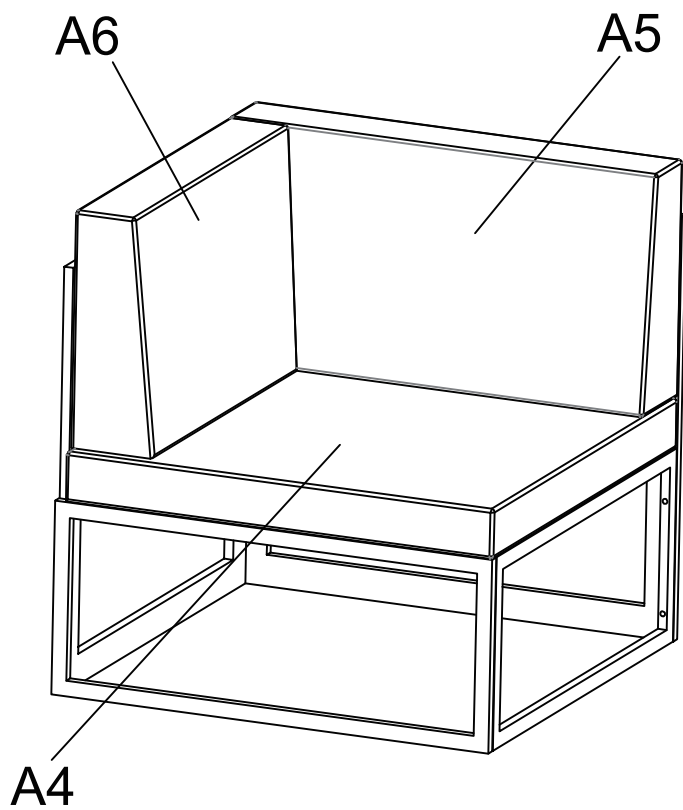

STEP 7

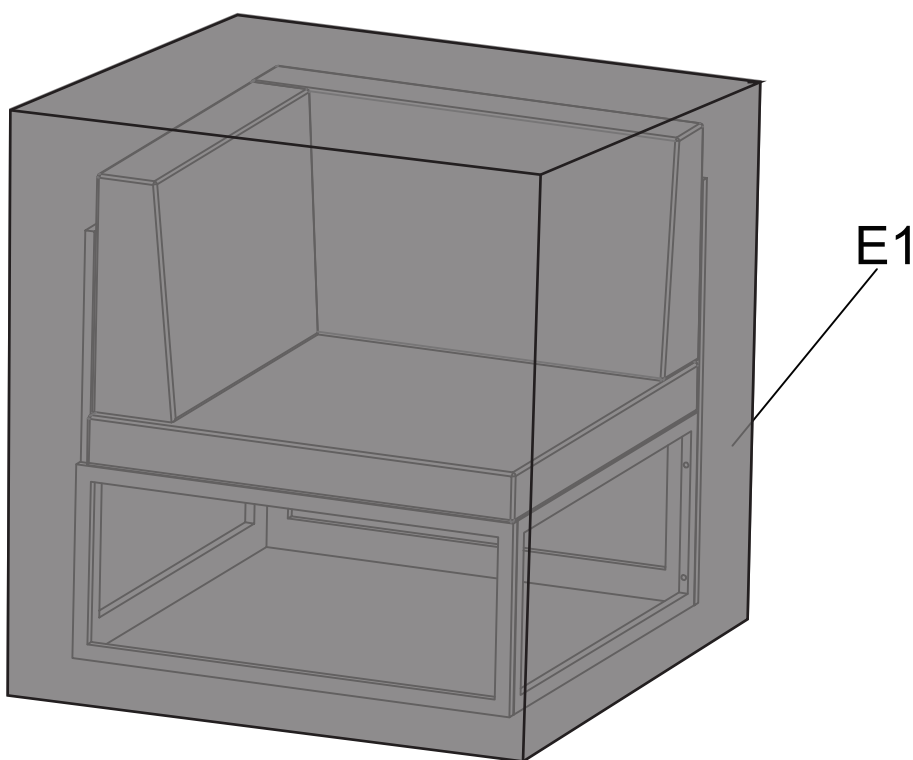

A4	
	Cushion
	1 pc
A5	
	Big backing
	1 pc
A6	
	Small backing
	1 pc

STEP 8



E1	
	Waterproof Cover
	1 pc

STEP 9

**The installation is complete.
Make sure all the screws are fully tighten.**

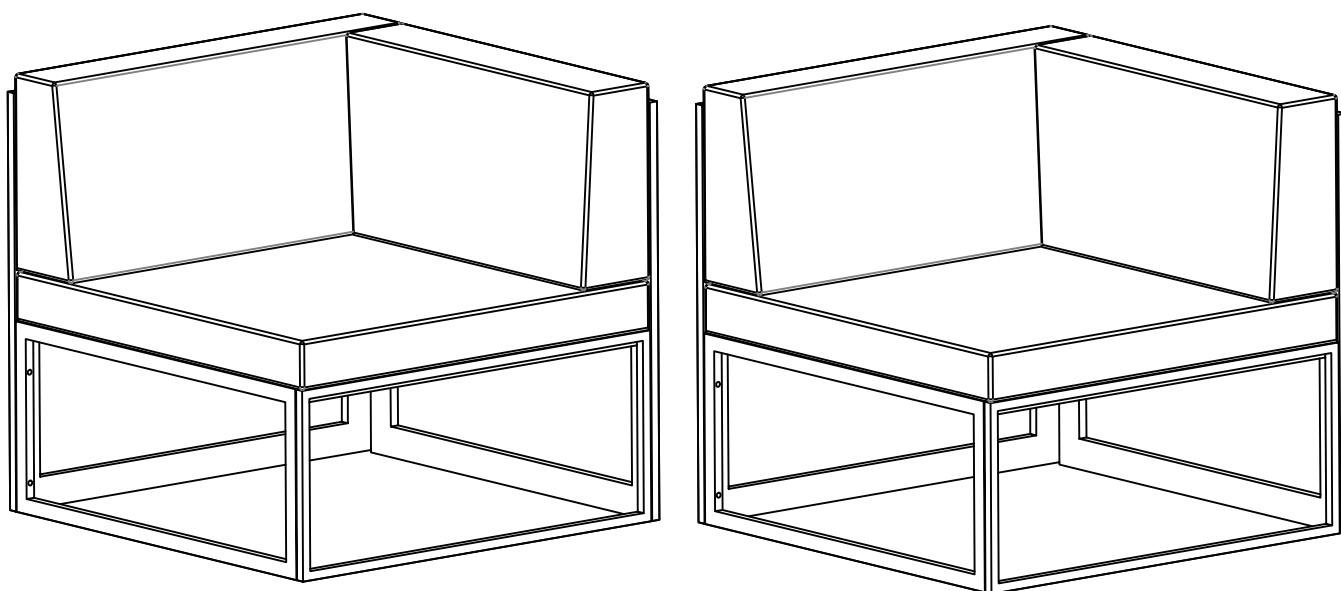

AFTER-SALE SERVICE CARD

If you have any suggestions for our products or find that the products have quality problems, please contact us first, our after-sales team will reply you within 24 hours, and we will do our best to give you solutions until you are satisfied.

Guaranteed Customer Service

Your shopping experience is very important to us!
Feel unsatisfied? **Contact us!**
Have any questions? **Contact us!**

Wanna share how wonderful our smart products makes your home?
Share your pictures with us.
Any suggestions? **Contact us!**
We gotcha back!

✉ Patiofurniture Serviceteam@outlook.com



Single Sofa*2

If you have any questions about the product, please feel free to contact us.

E-Mail: Patiofurniture Serviceteam@outlook.com

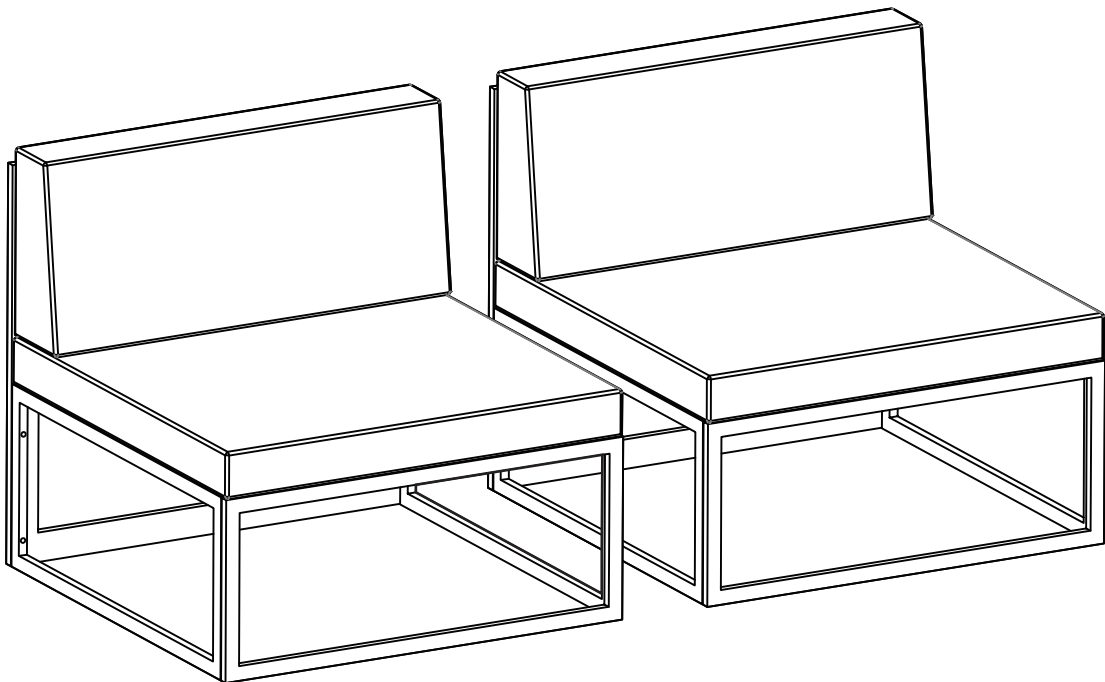

After-sales mailbox:
Patiofurniture Serviceteam@outlook.com

NOTICE



Please keep these instructions for future reference.

Dear Customer

● Thank you for your purchase. When you receive the product, please make sure that all the parts are intact. Then follow the entire installation instructions to install!

● **When installing, please be careful not to tighten the screws immediately! You need to make sure that all the screws are secured to 80%, then tighten them!**

A . The outer box is damaged

B . The product is damaged / bent / cracked while you open the box

C . The parts / accessories / assembly tools are missing

D . The instructions are not clear and can not be referred

E . The product has functional problems

F . Other aspects that you are not satisfied with

Please feel free to contact us for help. Our after-sales team service (Patiofurnitureseviceteam@outlook.com) will reply within 24 hours and will do our best to resolve the problem for you.





Please feel free to contact us for help, and provide the following information: Platform/Shop name/Order ID/buyer's name/ receiver's address/Problem description.

o



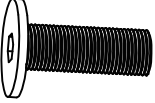
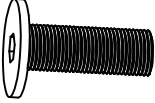
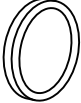

Please keep the original boxes for returns, refunds will be refused for other boxes. Check the integrity of the components and handle them gently during installation!

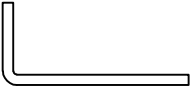
HARDWARE LIST

 S1 M6x25	 S2 M6x35	 S4	 S5 Screw head cover	 S6
16 pcs	16 pcs	32 pcs	32 pcs	8 pcs
 E1 Waterproof Cover	 T			
2 pcs	1 pc			

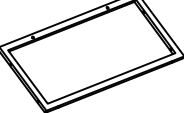
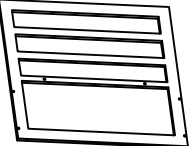
PART LIST

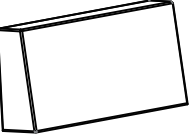
 A1 Large side piece	 B2 Small side piece	 B3 Back	 B4 Seat	 A4 Cushion
2 pcs	4 pcs	2 pcs	2 pcs	2 pcs
 A5 Big backing				
2 pcs				





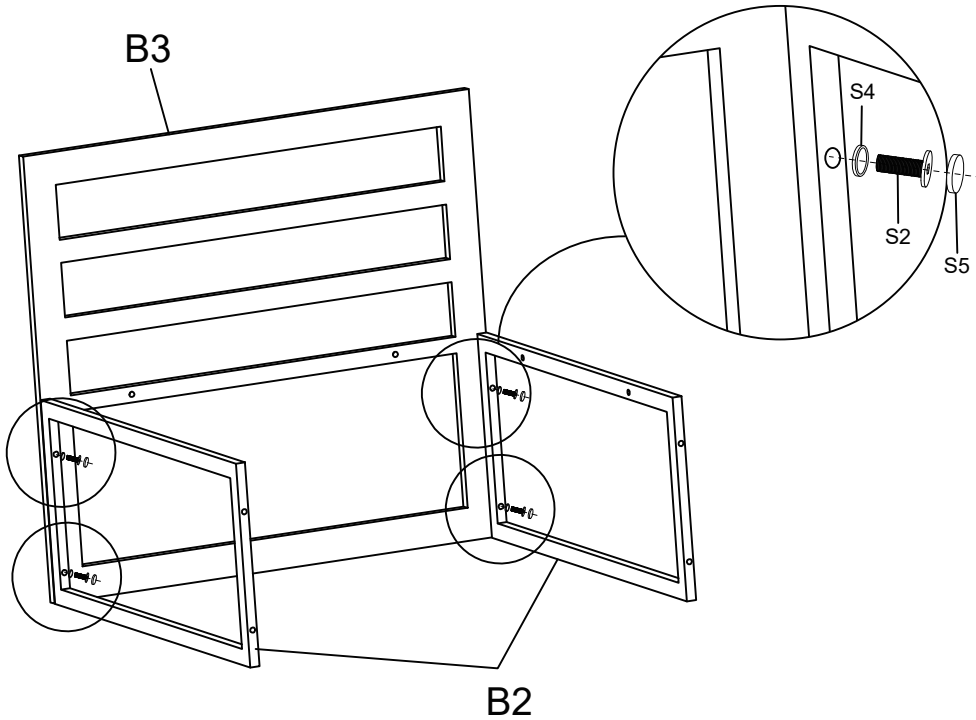

1. Please ensure that all accessories are complete before starting the installation.
 2. Due to the variety of accessories, many accessories may be glued together, please check carefully
 3. If any accessories are missing or damaged, please contact the seller immediately.
- E-Mail: Patiofurniture Serviceteam@outlook.com

STEP 1

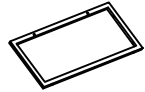
NOTICE

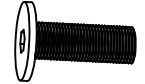



When installing, please be careful not to tighten the screws immediately!
You need to make sure that all the screws are secured to 80%, then tighten them!

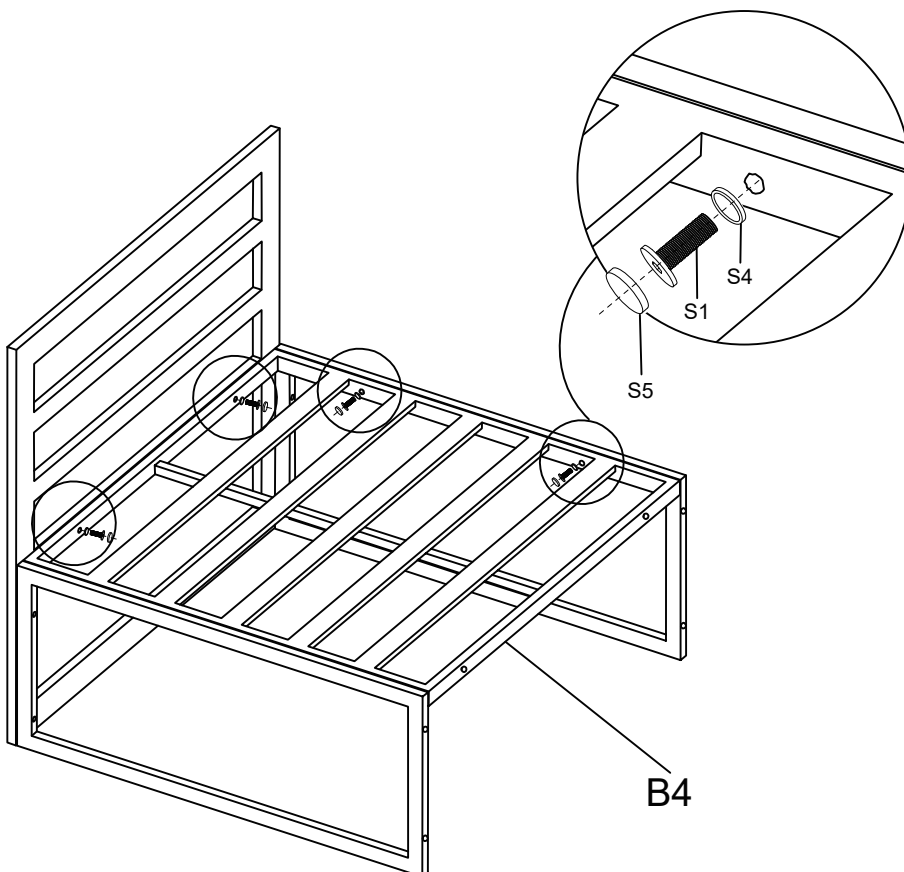

 Small side piece 2 pcs	 Back 1 pc
 M6x35 4 pcs	 S4 4 pcs
 Screw head cover 4 pcs	 T 1 pc

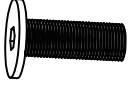

STEP 2



 Seat 1 pc	 M6x25 4 pcs
 S4 4 pcs	 Screw head cover 4 pcs
 T 1 pc	

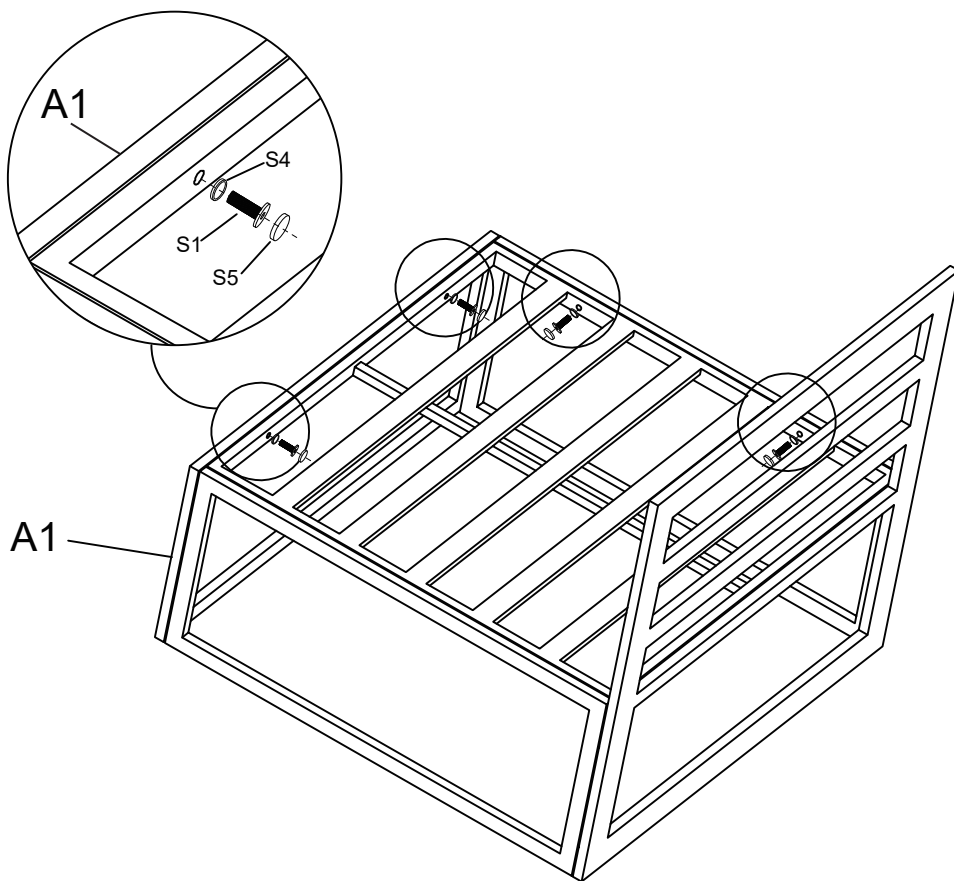

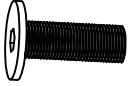
STEP 3

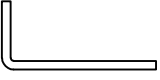

(A1) 	(S1) 
Large side piece	M6x25
1 pc	4 pcs
(S4) 	(S5) 
	Screw head cover
4 pcs	4 pcs
	(T) 
	1 pc

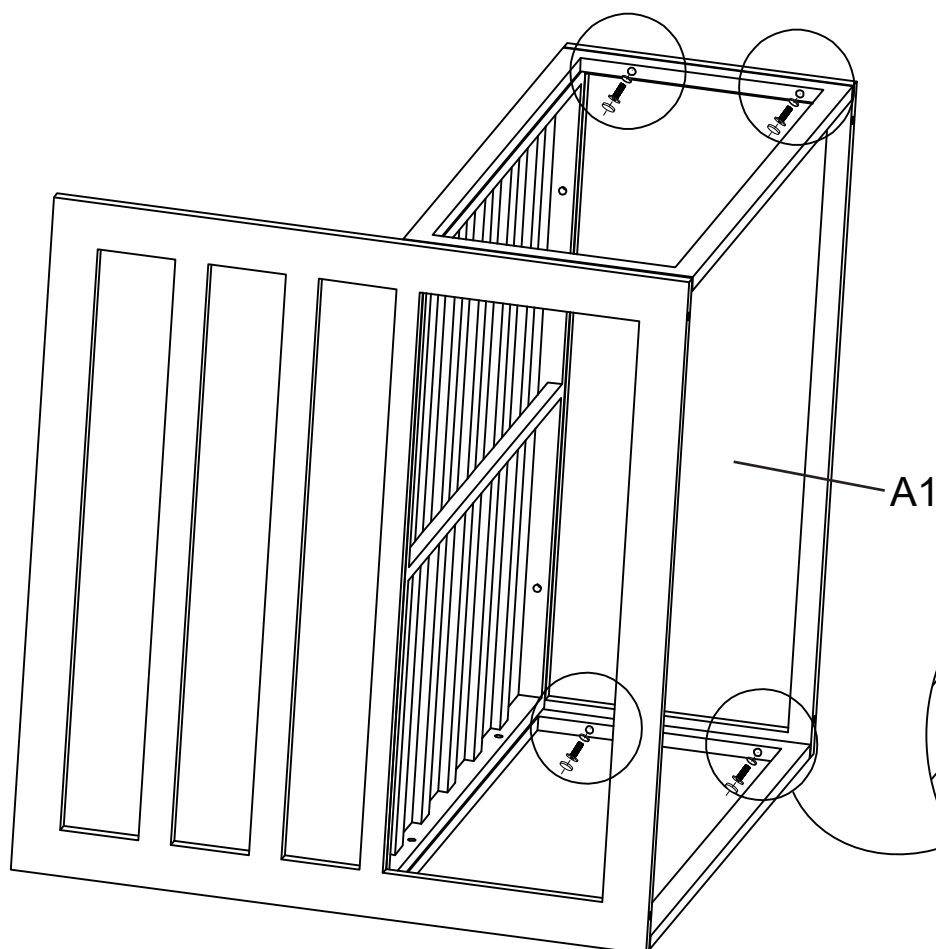
STEP 4

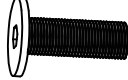

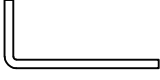
(S2) 	(S4) 
M6x35	
4 pcs	4 pcs
(S5) 	(T) 
Screw head cover	
4 pcs	1 pc

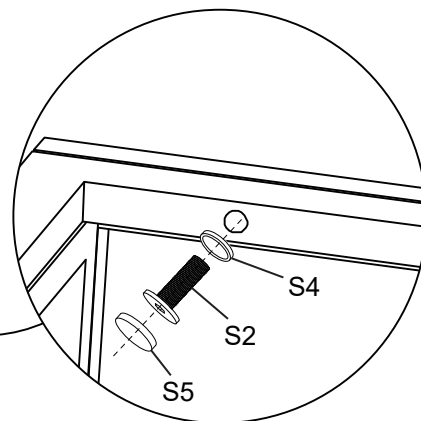

STEP 5

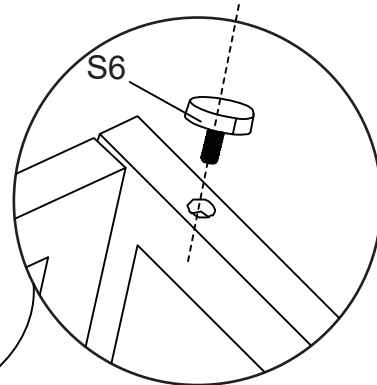
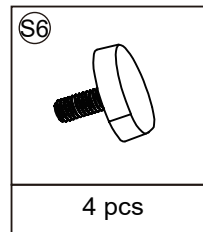
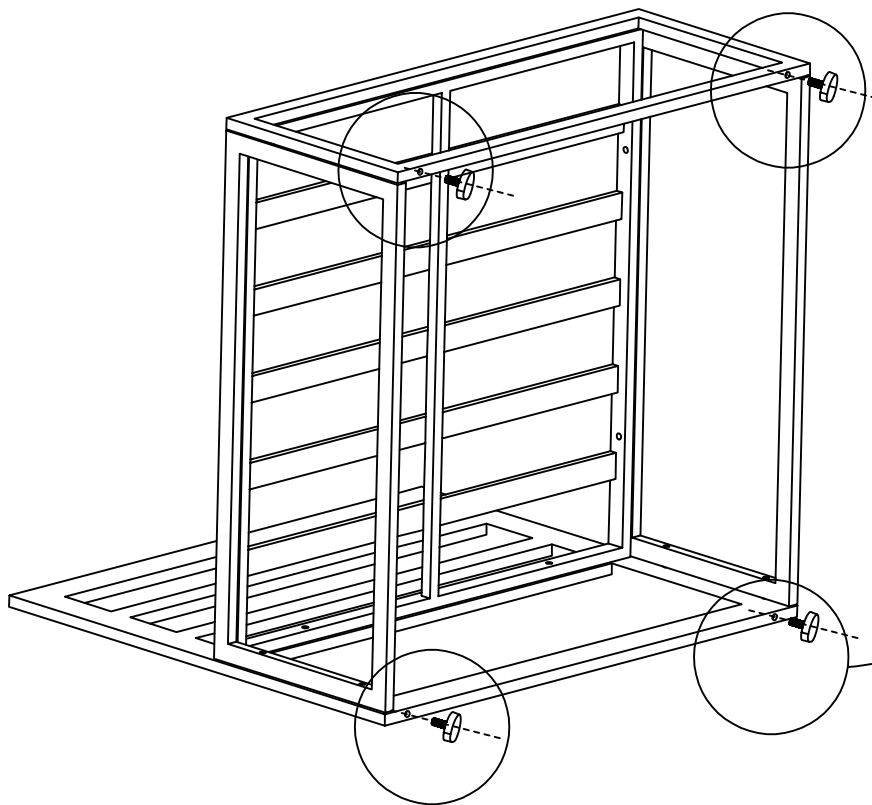

STEP 6

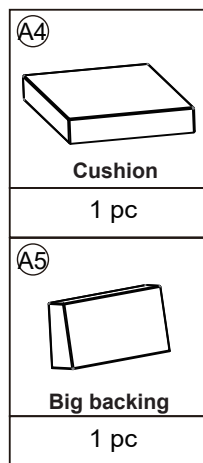
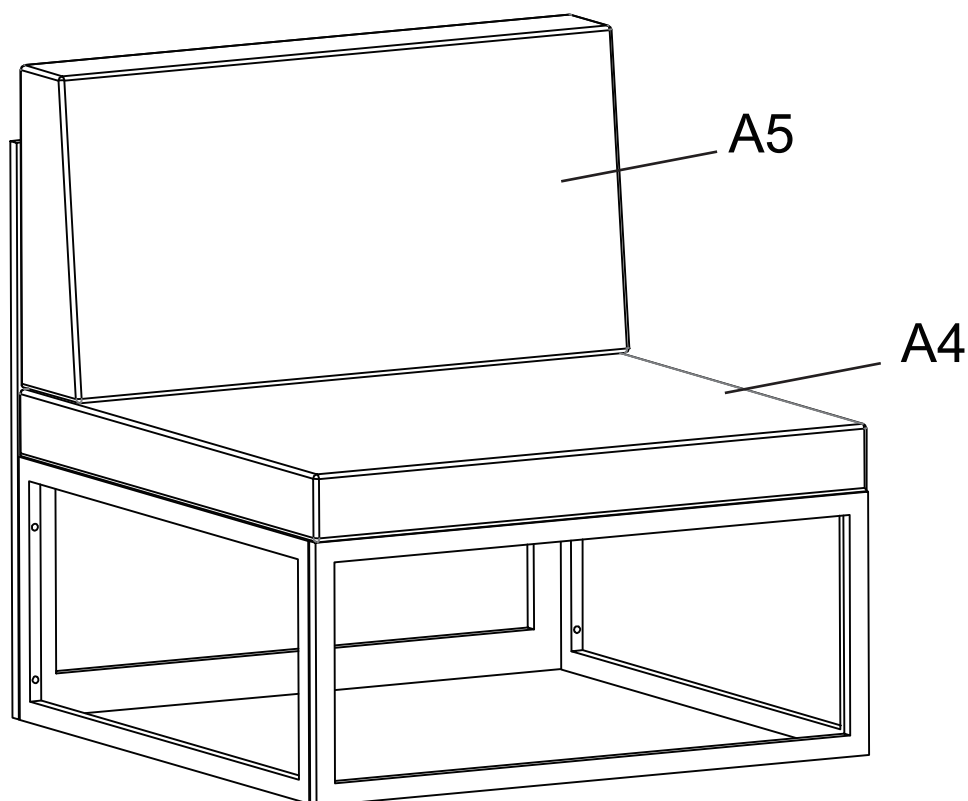

STEP 7

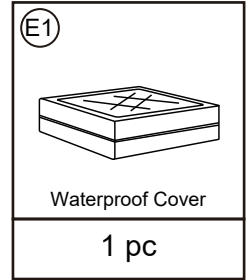
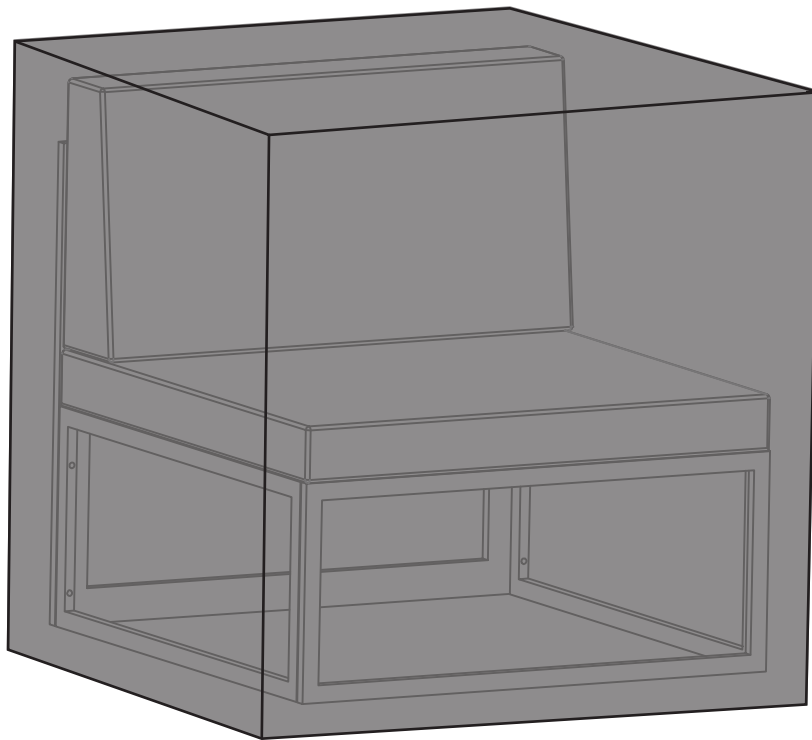

STEP 8

**The installation is complete.
Make sure all the screws are fully tighten.**

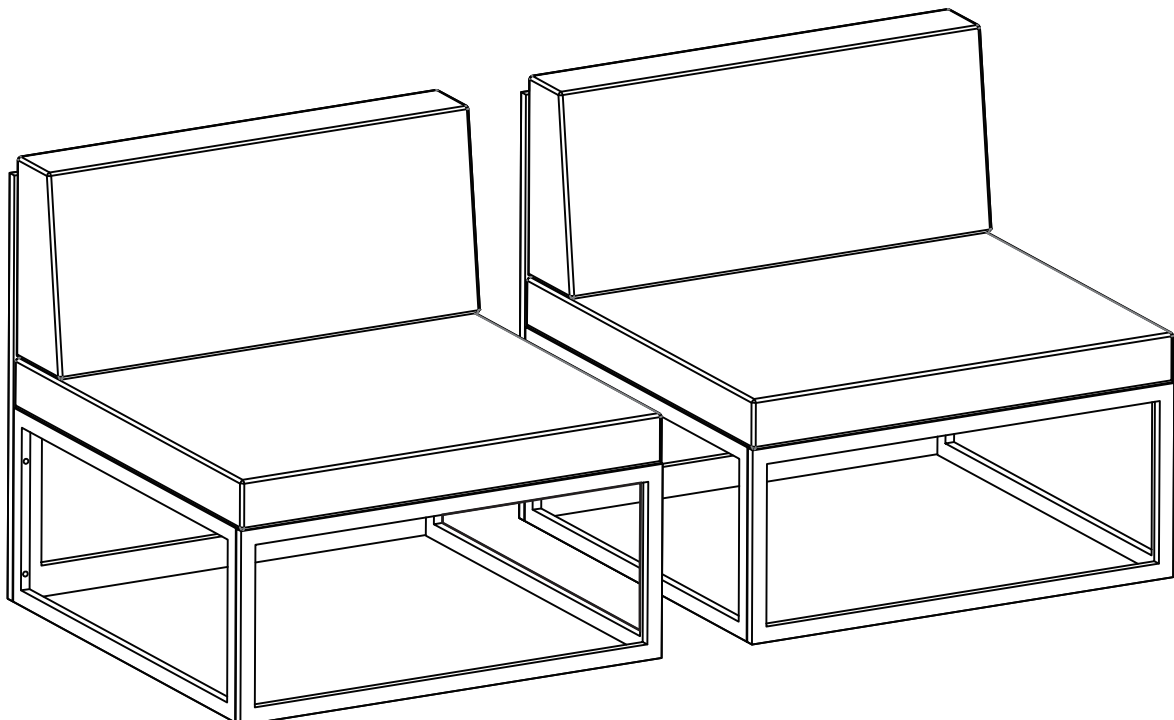

AFTER-SALE SERVICE CARD

If you have any suggestions for our products or find that the products have quality problems, please contact us first, our after-sales team will reply you within 24 hours, and we will do our best to give you solutions until you are satisfied.

Guaranteed Customer Service

Your shopping experience is very important to us!
Feel unsatisfied? **Contact us!**
Have any questions? **Contact us!**

Wanna share how wonderful our smart products makes your home?
Share your pictures with us.
Any suggestions? **Contact us!**
We gotcha back!

✉ Patiofurniture Serviceteam@outlook.com



Ottoman*2

If you have any questions about the product, please feel free to contact us.

E-Mail: Patiofurniture Serviceteam@outlook.com

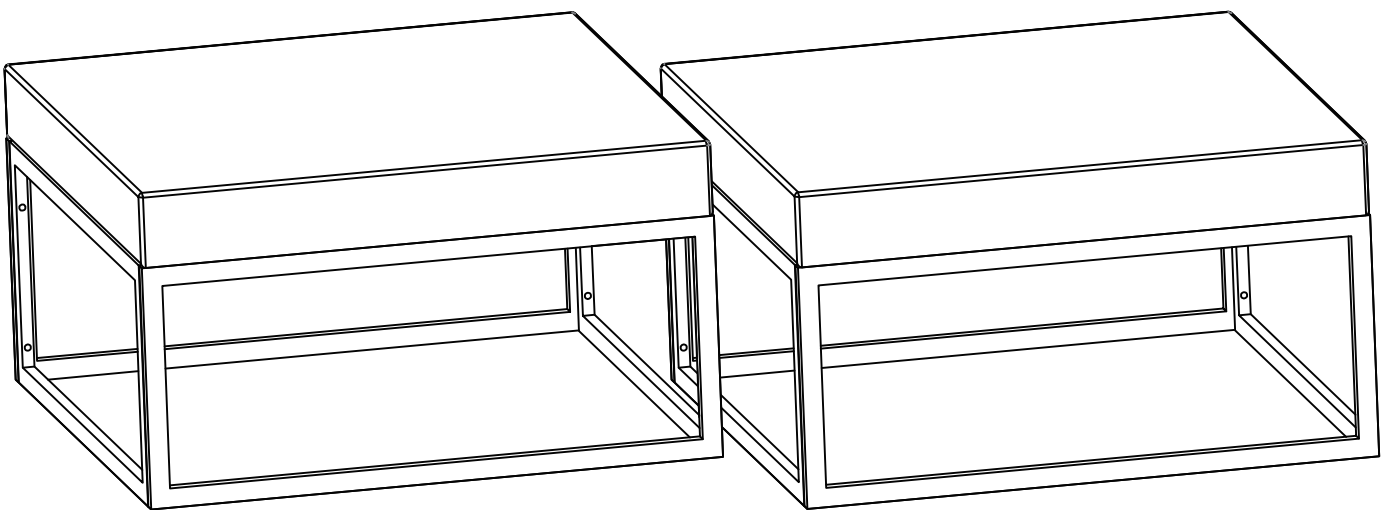

After-sales mailbox:
Patiofurniture Serviceteam@outlook.com

NOTICE



Please keep these instructions for future reference.

Dear Customer

● Thank you for your purchase. When you receive the product, please make sure that all the parts are intact. Then follow the entire installation instructions to install!

● **When installing, please be careful not to tighten the screws immediately! You need to make sure that all the screws are secured to 80%, then tighten them!**

A . The outer box is damaged

B . The product is damaged / bent / cracked while you open the box

C . The parts / accessories / assembly tools are missing

D . The instructions are not clear and can not be referred

E . The product has functional problems

F . Other aspects that you are not satisfied with

Please feel free to contact us for help. Our after-sales team service (Patiofurnituresevice@outlook.com) will reply within 24 hours and will do our best to resolve the problem for you.







Please feel free to contact us for help, and provide the following information: Platform/Shop name/Order ID/buyer's name/ receiver's address/Problem description.

o

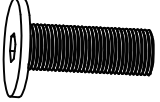
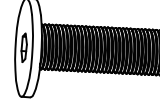

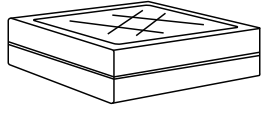

Please keep the original boxes for returns, refunds will be refused for other boxes. Check the integrity of the components and handle them gently during installation!

HARDWARE LIST

 <p>S1 M6x25</p>	 <p>S2 M6x35</p>	 <p>S4</p>	 <p>S5 Screw head cover</p>	 <p>S6</p>
16 pcs	16 pcs	32 pcs	32 pcs	8 pcs
 <p>E2 Waterproof Cover</p>	 <p>T</p>			
2 pcs	1 pc			

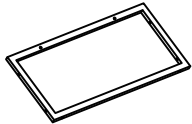
PART LIST

 <p>A1</p>	 <p>A2</p>	 <p>A3</p>	 <p>A4</p>
Large side piece	Small side piece	Face frame	Cushion
4 pcs	4 pcs	2 pcs	2 pcs

1. Please ensure that all accessories are complete before starting the installation.
2. Due to the variety of accessories, many accessories may be glued together, please check carefully
3. If any accessories are missing or damaged, please contact the seller immediately.



E-Mail: Patiofurniture Serviceteam@outlook.com

STEP 1

NOTICE

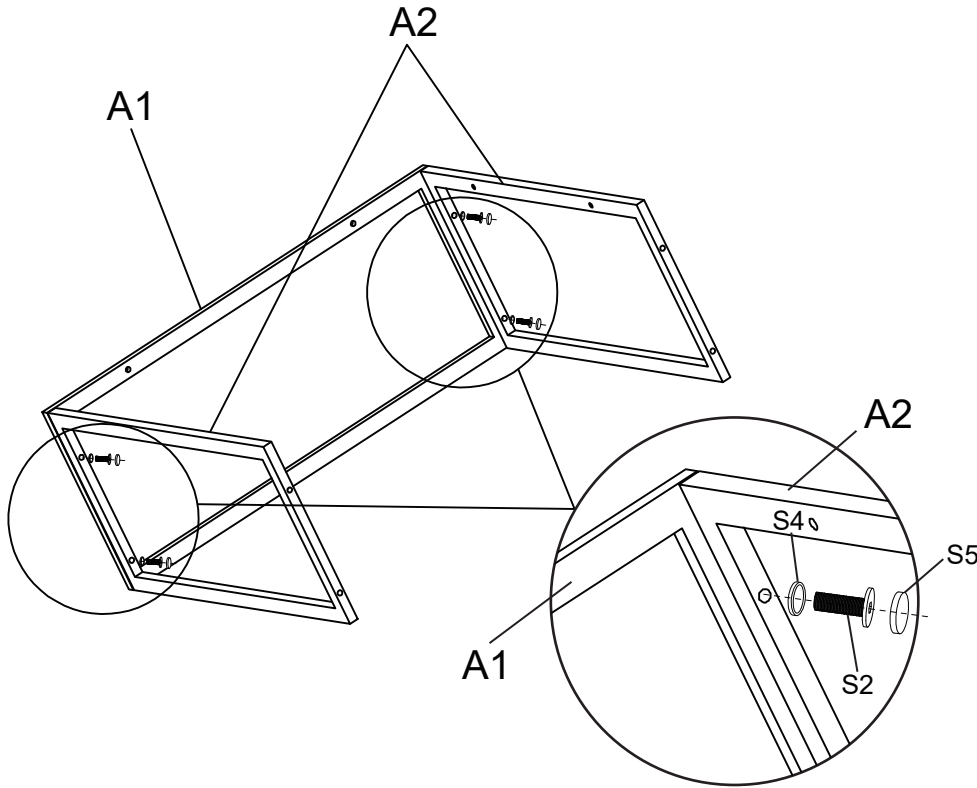

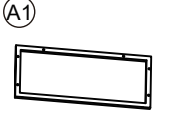
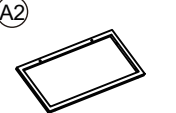
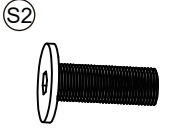
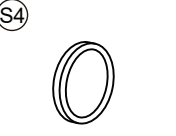
When installing, please be careful not to tighten the screws immediately!
You need to make sure that all the screws are secured to 80%, then tighten them!

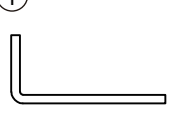

	
Large side piece	Small side piece
1 pc	2 pcs
	
M6x35	
4 pcs	4 pcs
	
Screw head cover	
4 pcs	1 pc

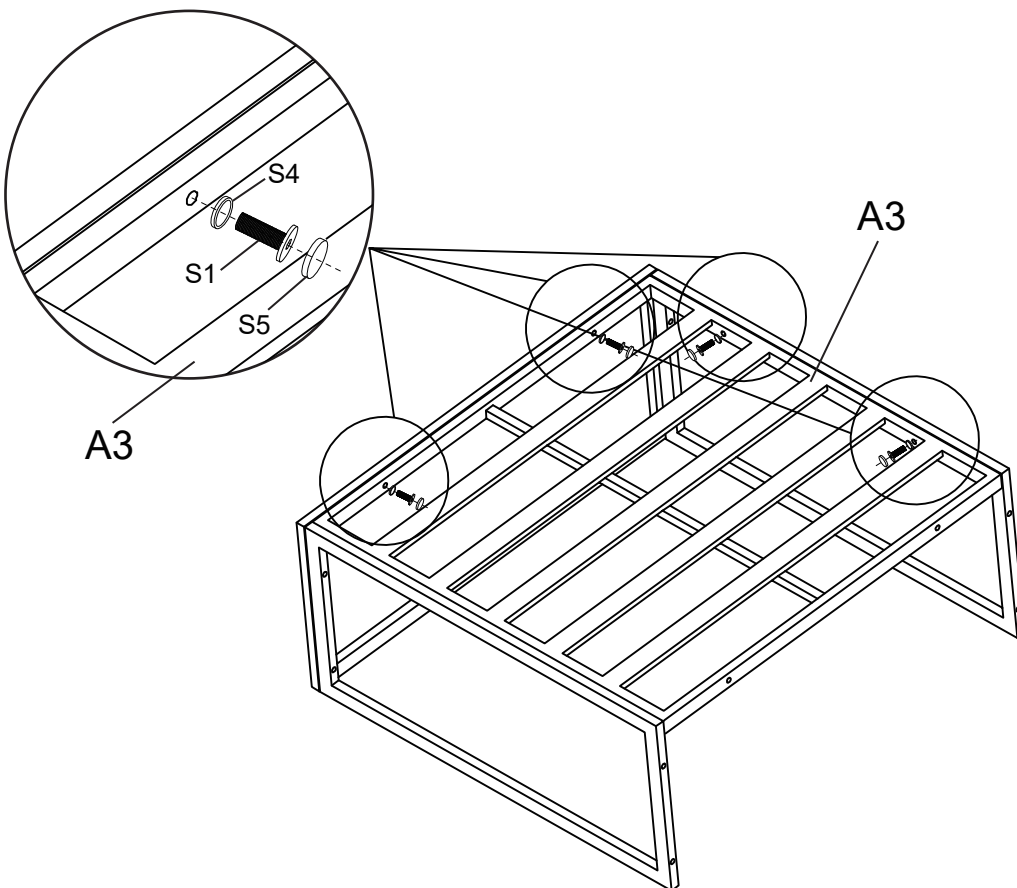

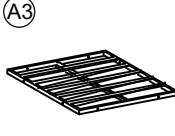
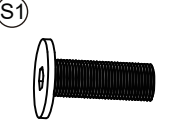
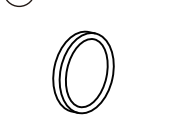
STEP 2

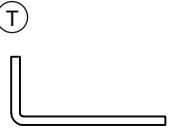

	
Face frame	M6x25
1 pc	4 pcs
	
	Screw head cover
4 pcs	4 pcs
	
	1 pc

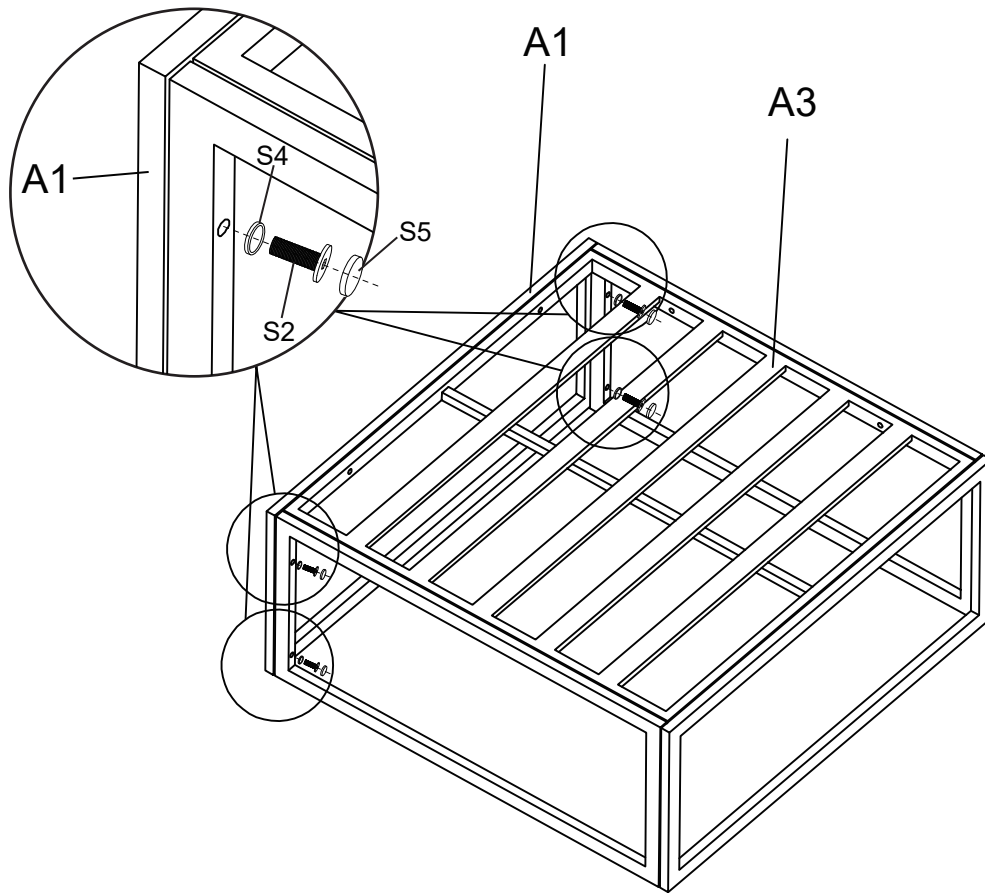

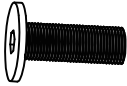
STEP 3

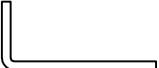

(A1) 	(S2) 
Large side piece	M6x35
1 pc	4 pcs
(S4) 	(S5) 
	Screw head cover
4 pcs	4 pcs
	(T) 
	1 pc

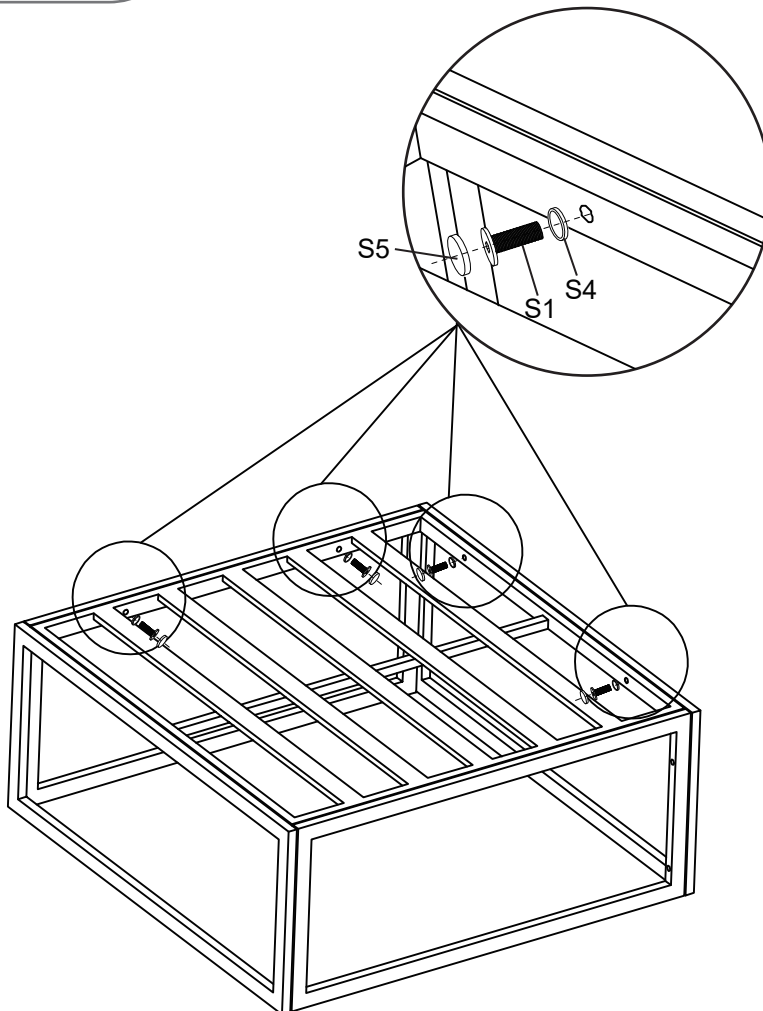
STEP 4

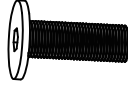

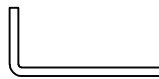
(S1) 	(S4) 
M6x25	
4 pcs	4 pcs
(S5) 	(T) 
Screw head cover	
4 pcs	1 pc

STEP 5

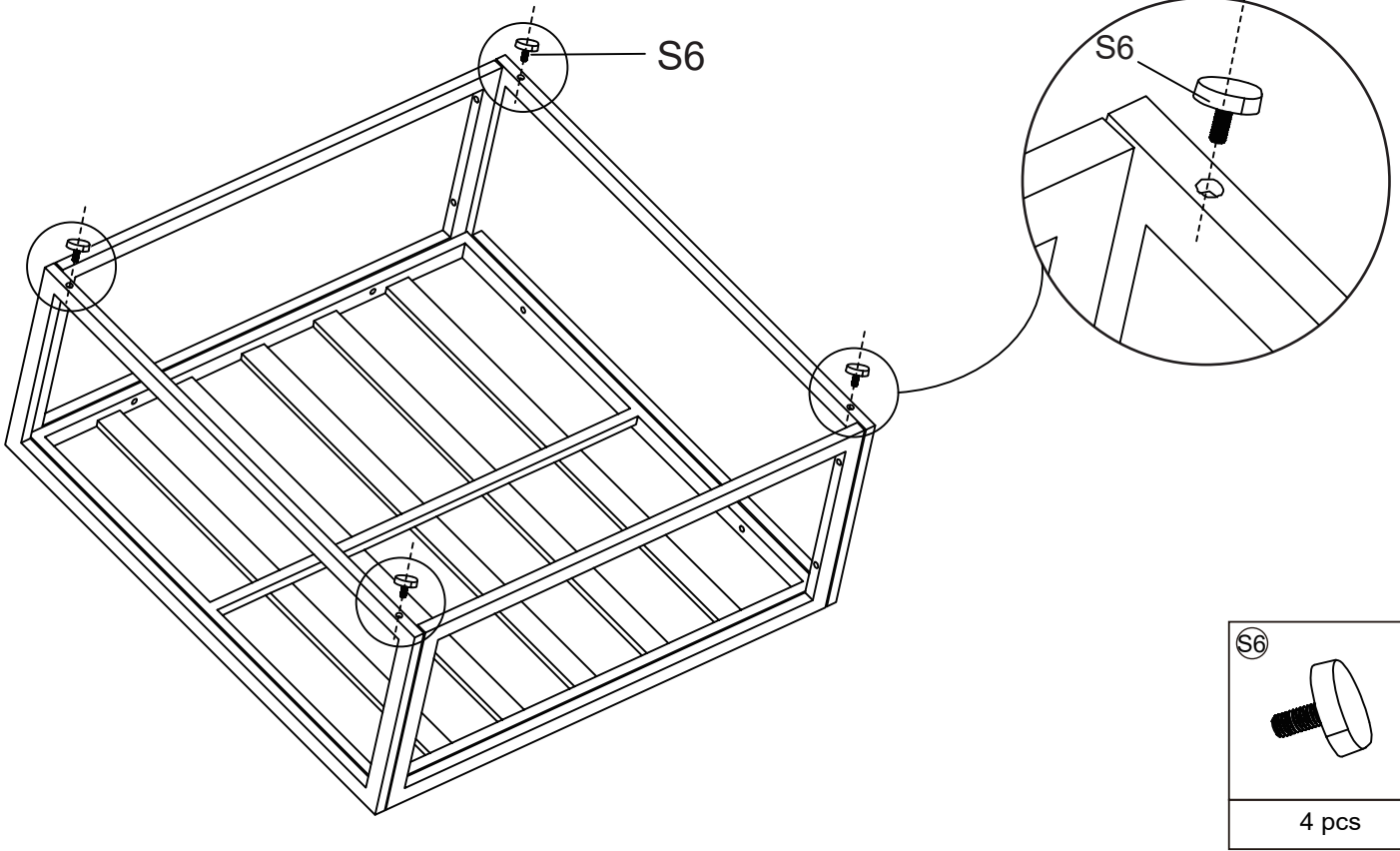

STEP 6

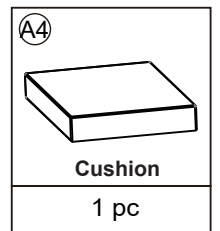
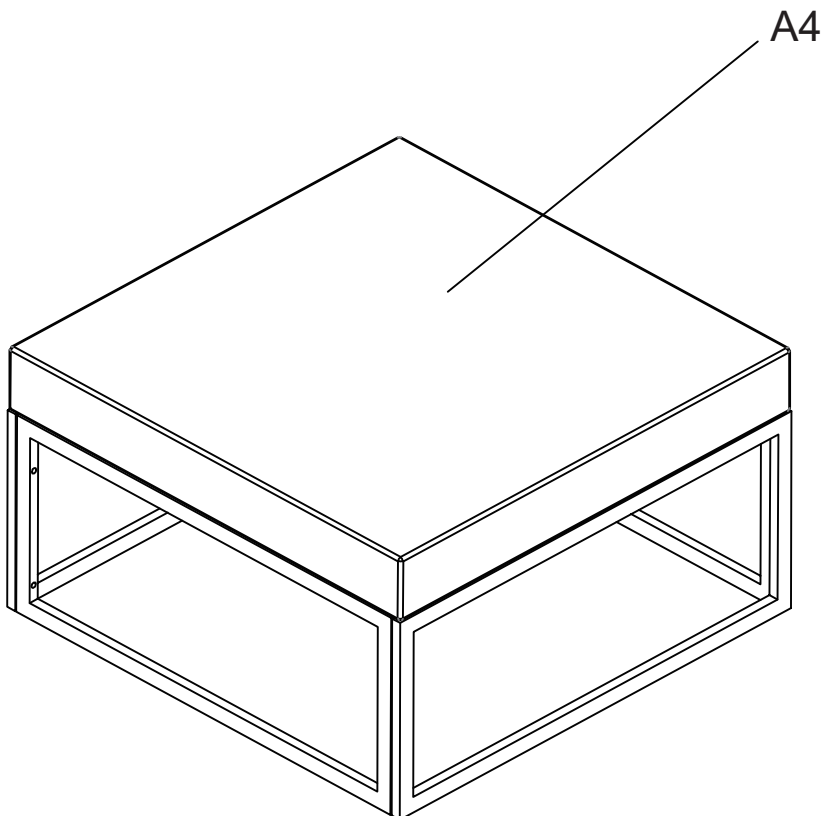

STEP 7

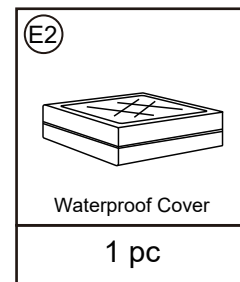
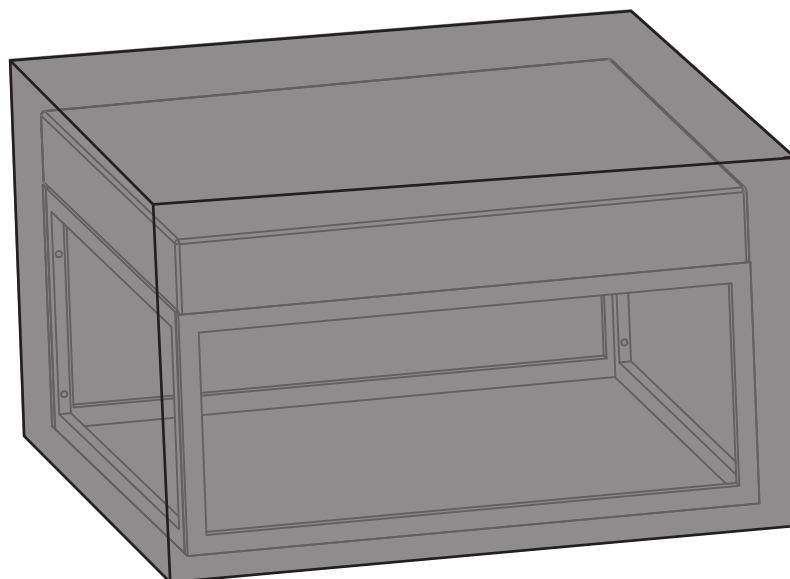

STEP 8

**The installation is complete.
Make sure all the screws are fully tighten.**

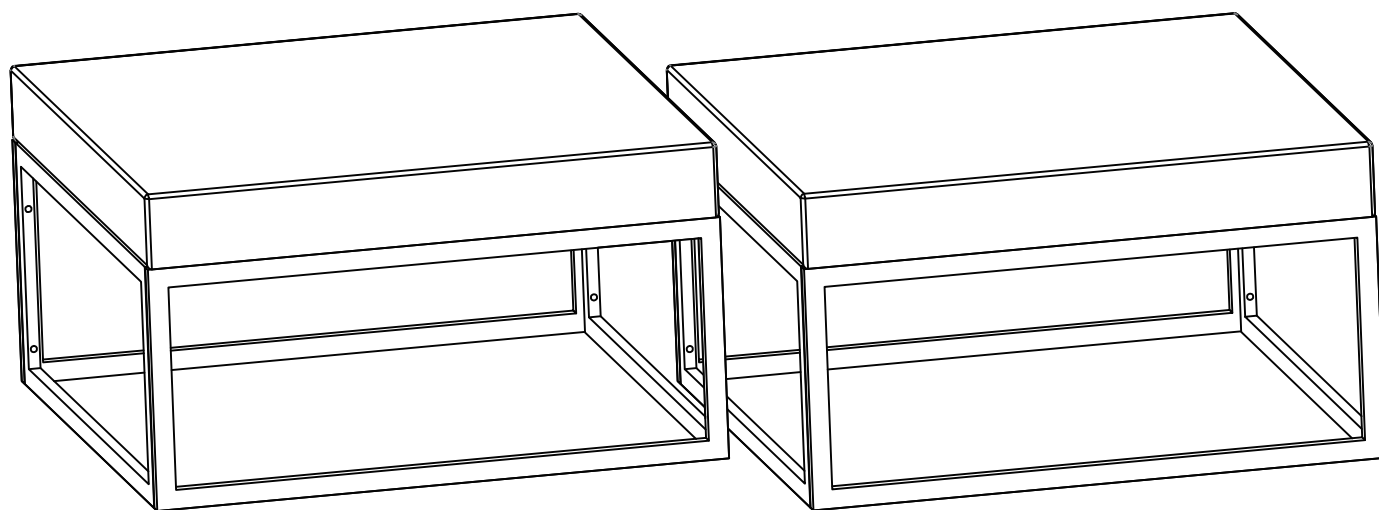

AFTER-SALE SERVICE CARD

If you have any suggestions for our products or find that the products have quality problems, please contact us first, our after-sales team will reply you within 24 hours, and we will do our best to give you solutions until you are satisfied.

Guaranteed Customer Service

Your shopping experience is very important to us!
Feel unsatisfied? **Contact us!**
Have any questions? **Contact us!**

Wanna share how wonderful our smart products makes your home?
Share your pictures with us.
Any suggestions? **Contact us!**
We gotcha back!

✉ Patiofurniture Serviceteam@outlook.com



Coffee Table

If you have any questions about the product, please feel free to contact us.

E-Mail: Patiofurniture Serviceteam@outlook.com

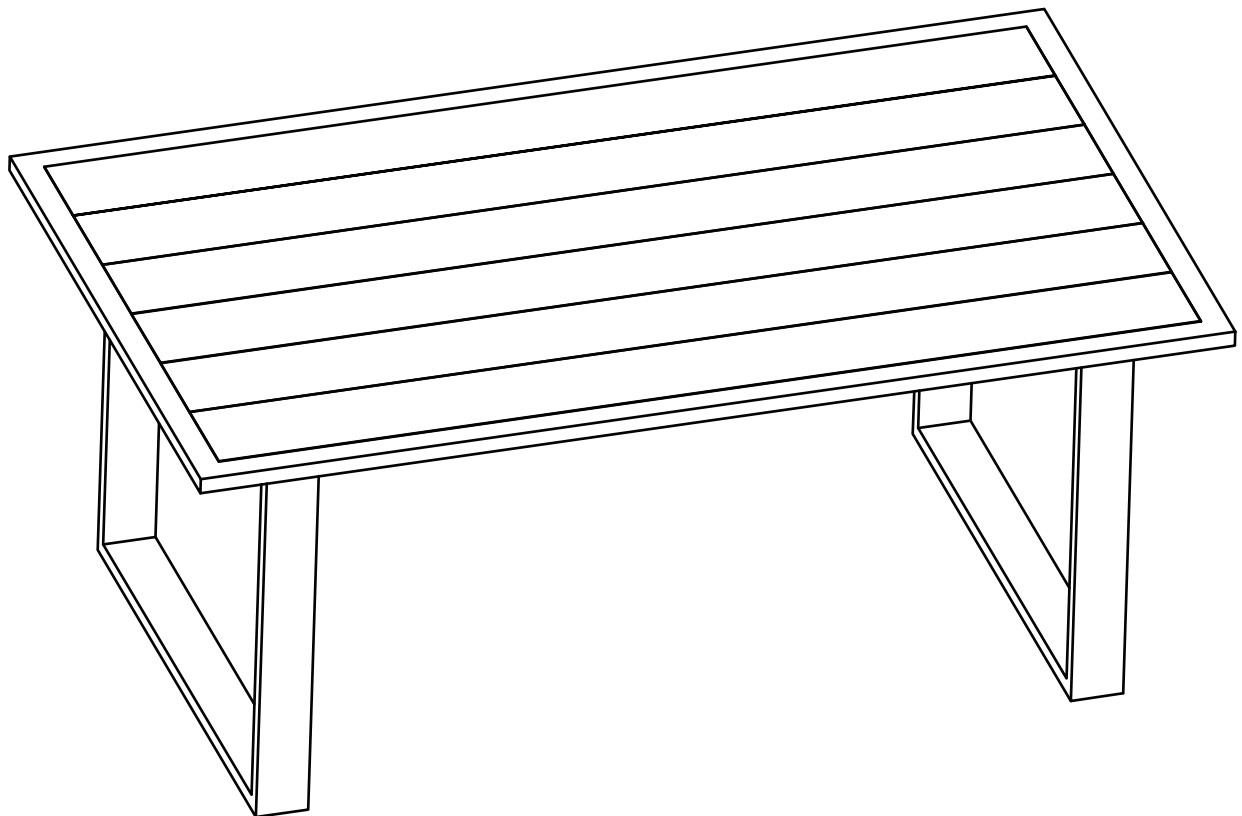

After-sales mailbox:
Patiofurniture Serviceteam@outlook.com

NOTICE



Please keep these instructions for future reference.

Dear Customer

● Thank you for your purchase. When you receive the product, please make sure that all the parts are intact. Then follow the entire installation instructions to install!

● **When installing, please be careful not to tighten the screws immediately! You need to make sure that all the screws are secured to 80%, then tighten them!**

A . The outer box is damaged

B . The product is damaged / bent / cracked while you open the box

C . The parts / accessories / assembly tools are missing

D . The instructions are not clear and can not be referred

E . The product has functional problems

F . Other aspects that you are not satisfied with





Please feel free to contact us for help. Our after-sales team service (Patiofurniturese-
viceteam@outlook.com) will reply within 24 hours and will do our best to resolve the
problem for you.

**Please feel free to contact us for help, and provide the following information: Plat-
form/Shop name/Order ID/buyer's name/ receiver's address/Problem description.**

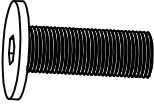
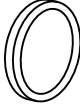

Please keep the original boxes for returns, refunds will be refused for other boxes. Check the integrity of the components and handle them gently during installation!

HARDWARE LIST

<p>(S1)</p>  <p>M6x25</p>	<p>(S4)</p> 	<p>(S5)</p>  <p>Screw head cover</p>	<p>(S6)</p> 	<p>(T)</p> 
8 pcs	8 pcs	8 pcs	4 pcs	1 pc

PART LIST

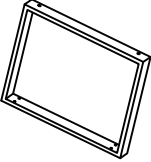
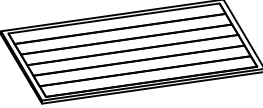
<p>(D1)</p>  <p>Left foot</p>	<p>(D2)</p>  <p>Desktop</p>
2 pcs	1 pc

1. Please ensure that all accessories are complete before starting the installation.
2. Due to the variety of accessories, many accessories may be glued together, please check carefully
3. If any accessories are missing or damaged, please contact the seller immediately.

E-Mail: Patiofurniture Serviceteam@outlook.com

STEP 1

NOTICE

When installing, please be careful not to tighten the screws immediately!
You need to make sure that all the screws are secured to 80%, then tighten them!

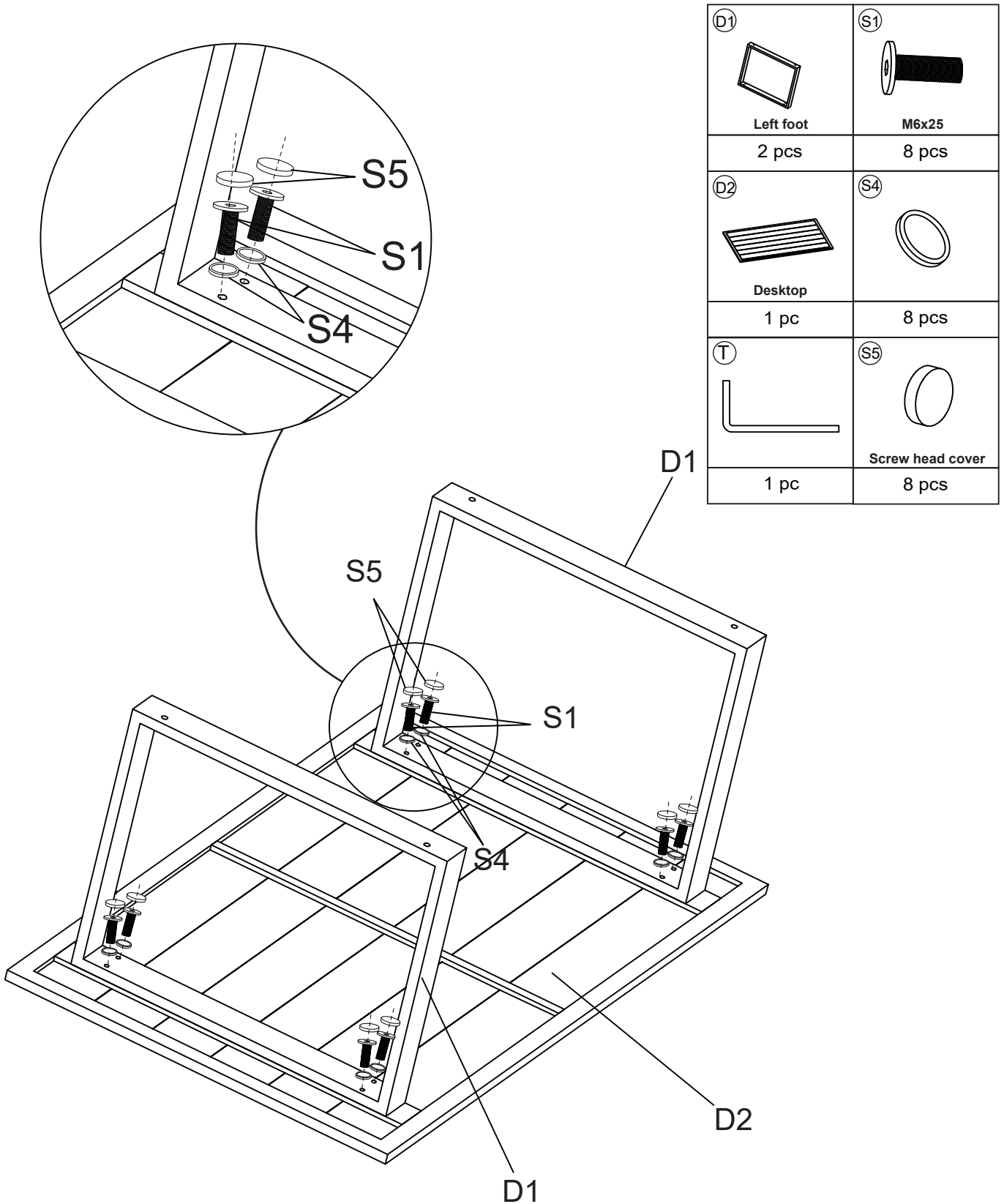

STEP 2

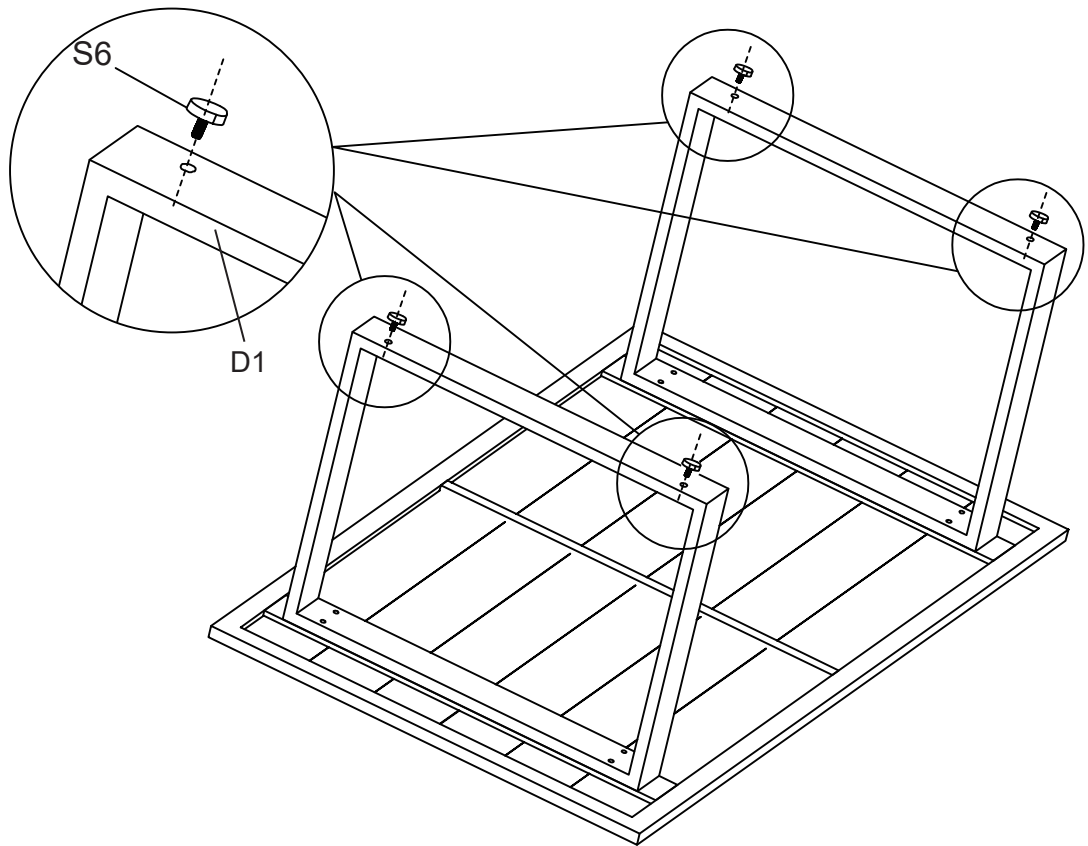

STEP 3

**The installation is complete.
Make sure all the screws are fully tighten.**

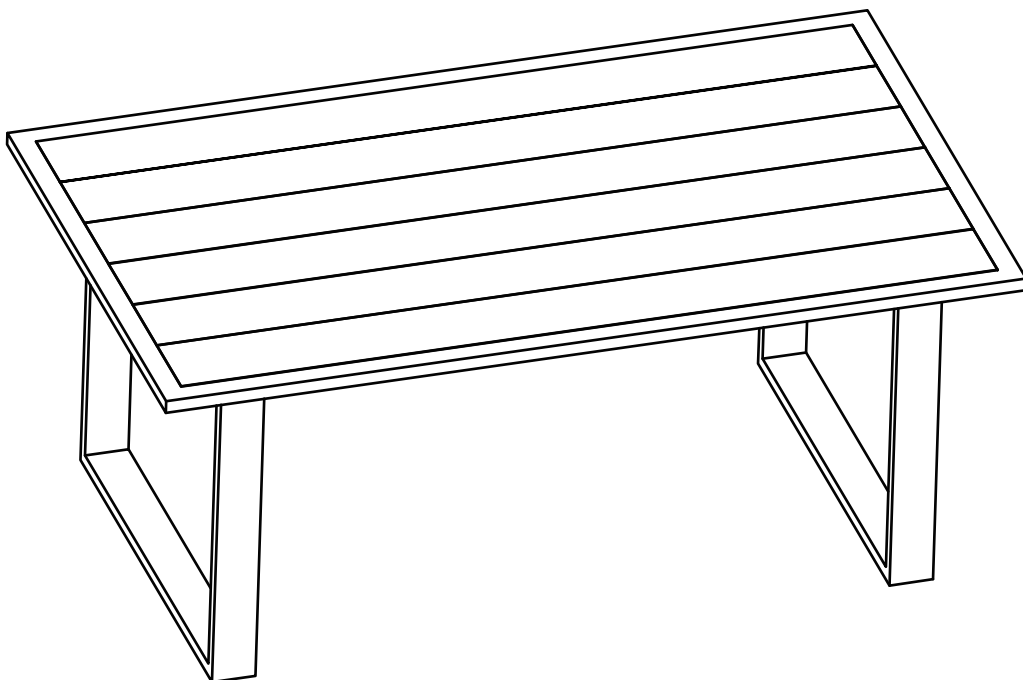

AFTER-SALE SERVICE CARD

If you have any suggestions for our products or find that the products have quality problems, please contact us first, our after-sales team will reply you within 24 hours, and we will do our best to give you solutions until you are satisfied.

Guaranteed Customer Service

Your shopping experience is very important to us!
Feel unsatisfied? **Contact us!**
Have any questions? **Contact us!**

Wanna share how wonderful our smart products makes your home?
Share your pictures with us.
Any suggestions? **Contact us!**
We gotcha back!

✉ Patiofurniture Serviceteam@outlook.com

