

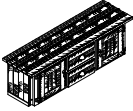





ASSEMBLY INSTRUCTION

Thank you for purchasing this quality product. Be sure to check all packing material carefully for small parts which may have come loose inside the carton during shipment. Separate, identify and count all parts and metal hardware. Compare with parts list to be sure all parts are present. If any part(s) are missing or damaged, please contact your local furniture dealer. For efficient and speedy service, please indicate the model number and code letter of part(s) needed.

***** Do not fully tighten screws until fully assembled *****

No.	COMPONENT LIST		Q'ty	No.	HARDWARE LIST		Q'ty
(A)		Side Table Frame	1pc	1		Bolts 5/16x50mm	12pcs
(B)		Legs	4pcs	2		Lock Washer 5/16	12pcs
(C)		Shelf	1pc	3		Flat Washer 5/16	12pcs
				4		Allen key K4	1pcs

Step 2 : Align and place Shelves (c) into legs (B). Use Bolt (1), lock washer(2), flat washer(3). Then use Allen key (4) fully tighten bolt places.

Step 1 : Open doors, Align and place Legs (B) into Side table frame (A). Use Bolt (1), lock washer(2), flat washer(3) then do not fully tighten bolt places.

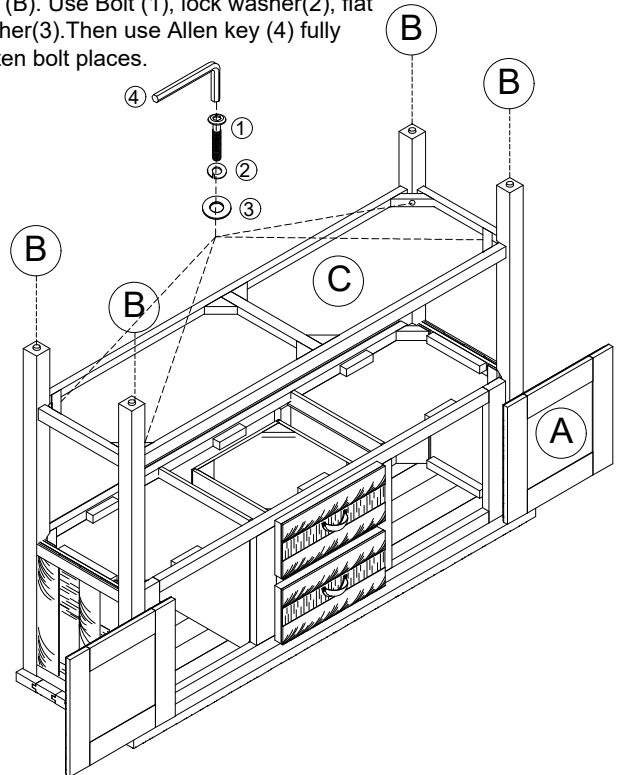
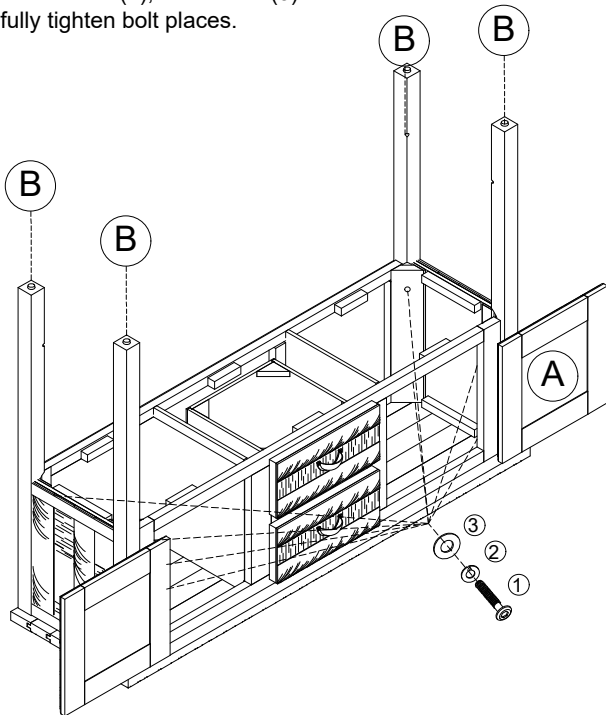

Step 3 : Close the doors

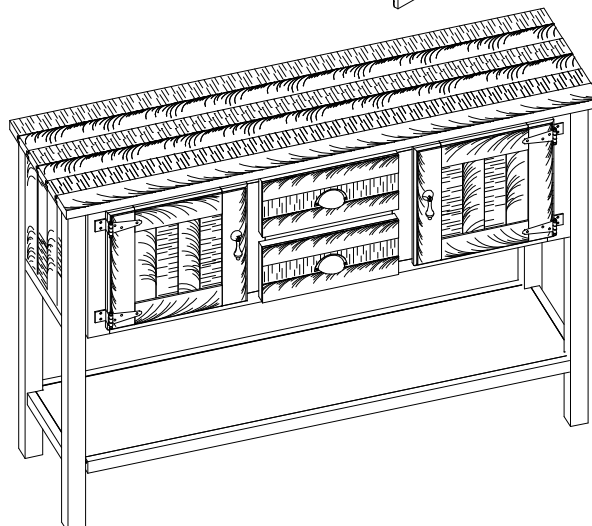

**FINISH .
THANK YOU !**