

4836344COM 5 Drawer Dresser

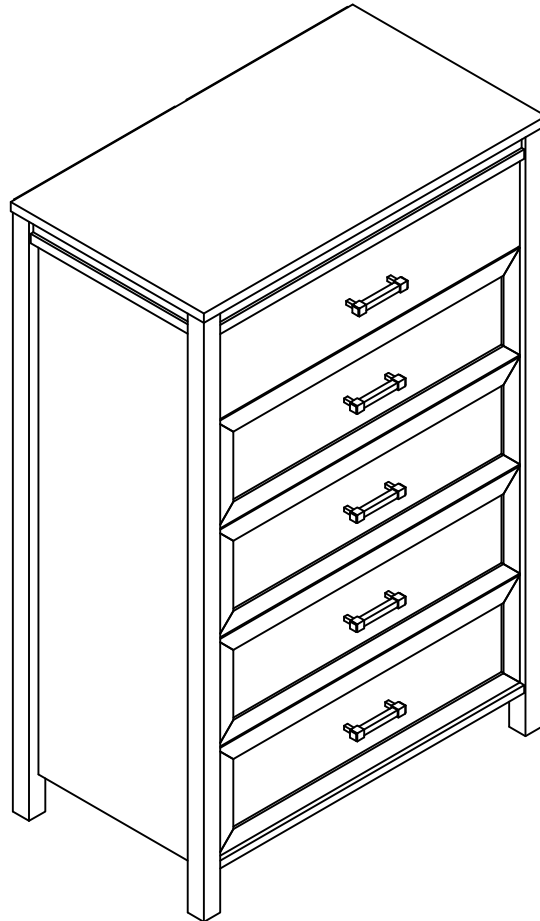

Date of Purchase ___ / ___ / ___
Lot Number:

B344836344COM0



Do Not Return This Product!
Contact our customer service team for help first.
Call: 1-800-489-3351 (toll free)
Monday-Friday 9am - 5pm CST
Visit: www.ameriwoodhome.com

THIS INSTRUCTION BOOKLET CONTAINS **IMPORTANT** SAFETY INFORMATION. PLEASE READ AND KEEP FOR FUTURE REFERENCE.

Secure Your Furniture

Keep your home and family safe with the wall anchor kit that is included with the product.



Serious or fatal crushing injuries can occur from tipping furniture.

WARNING: Manufacturer assumes no liability for improper installation or excessive loads placed on screws or bracket. This wall anchor is not a substitute for proper adult supervision.



Follow Ameriwood Home



Contact Us!

Do NOT return this product!

Contact our friendly customer service team first for help.

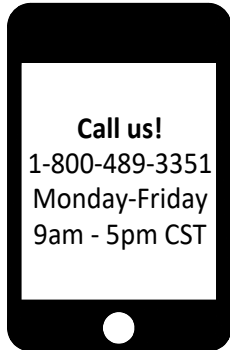

Visit ameriwoodhome.com to view the limited warranty valid in the U.S. and Canada.

Assembly Tips



Helpful Hints

PEOPLE NEEDED FOR ASSEMBLY: 2

ESTIMATED ASSEMBLY TIME: 1 HOUR

- Open your item in the area you plan to keep it to avoid excessive heavy lifting.
- Identify, sort and count the parts before attempting assembly.
- Compression dowels are lightly tapped in with a hammer.
- Slides are labeled with a **R** (right) and **L** (left) for proper placement.
- Make sure to always face the point on the top of the Cam Lock towards the outer edge.
- Use all the nails provided for the back panel and spread them out equally.
- Back panel must be used to make sure your unit is sturdy.
- Do NOT use harsh chemicals or abrasive cleaners on this item.
- Never push, pull, or drag your furniture.



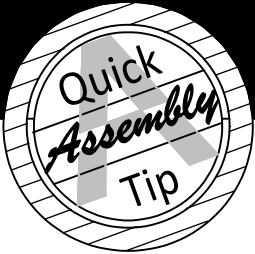

Before You Start

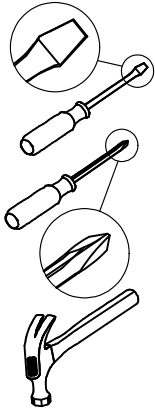

- ✓ Read through each step carefully and follow the proper order
- ✓ Separate and count all your parts and hardware
- ✓ Give yourself enough room for the assembly process
- ✓ Have the following tools: Flat Head Screwdriver, #2 Phillips Head Screwdriver and Hammer
- ✓ Caution: If using a power drill or power screwdriver for screwing, please be aware to slow down and stop when screw is tight. Failure to do so may result in stripping the screw.

Cam Lock Fastening System

This Cam Lock Fastening System will be used throughout the assembly process.

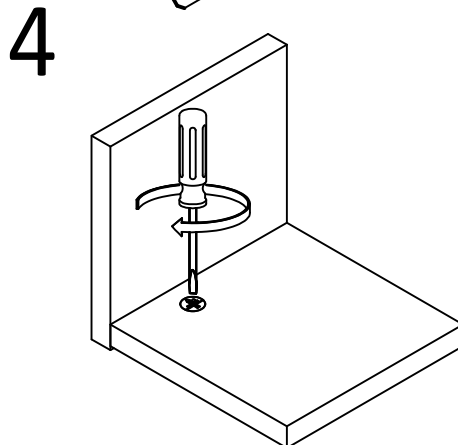
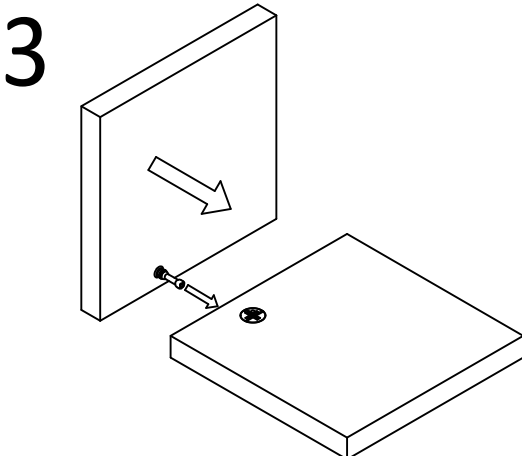
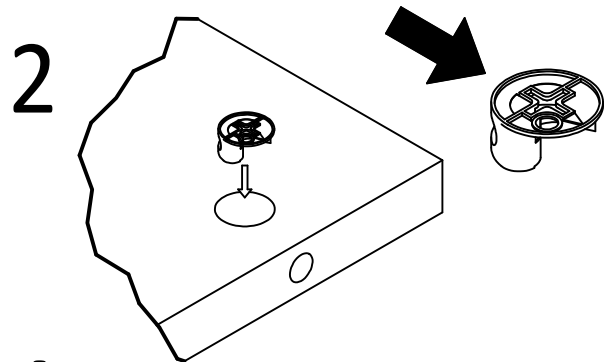
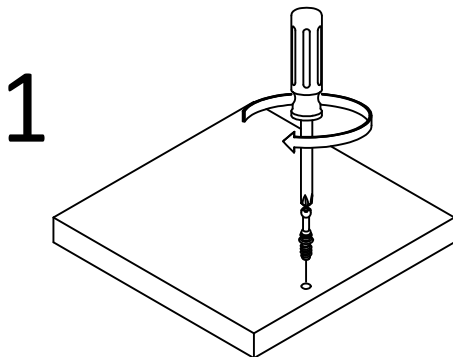

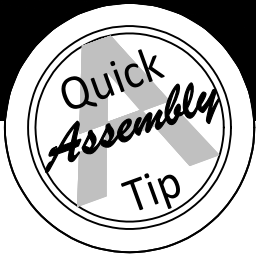

Before You Start

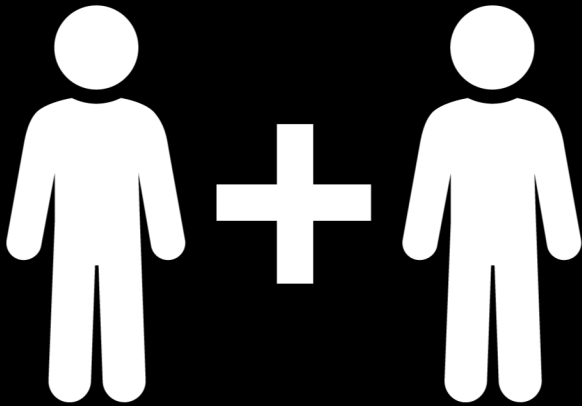

2 PEOPLE NEEDED FOR ASSEMBLY

**2 PERSONAS NECESITADAS
PARA LA ASAMBLEA**

**2 PERSONNES NÉCESSAIRES
POUR L'ASSEMBLAGE**

CAUTION: Failure to use 2 people for assembly could result in unit damage or personal injury.

PRECAUCIÓN: Si no se utilizan 2 personas para el ensamblaje, se pueden producir daños en la unidad o lesiones personales.

ATTENTION: Échec d'utiliser 2 personnes pour l'assemblage peut causer du dommage au meuble ou causer des blessures.

Board Identification

Not actual size

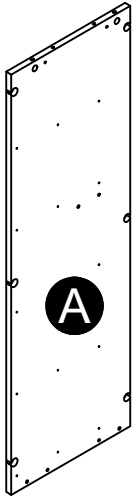

Left Panel
34836344010

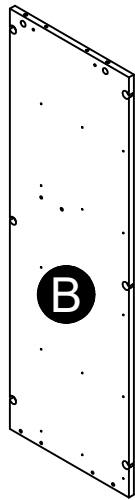

Right Panel
34836344020

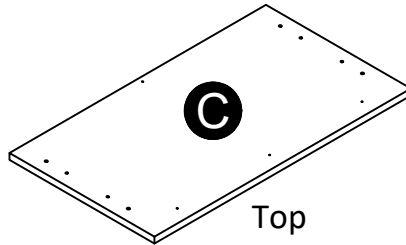

Top
34836344030

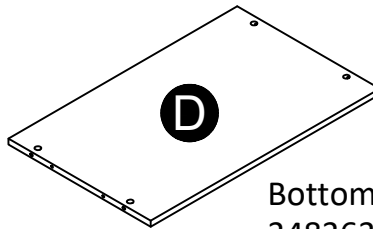

Bottom
34836344040

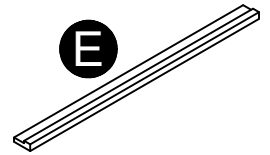

Top Rail
34836344050

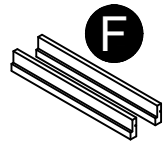

Side Rail (2)
34836344060

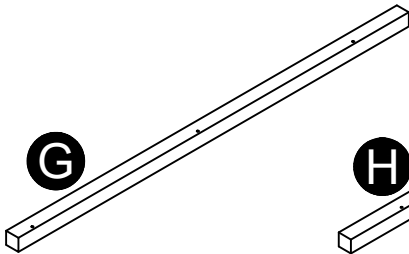

Left Front Leg
34836344070

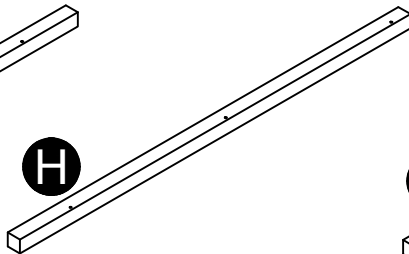

Right Front Leg
34836344080

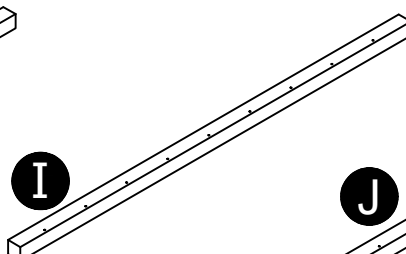

Left Rear Leg
34836344090

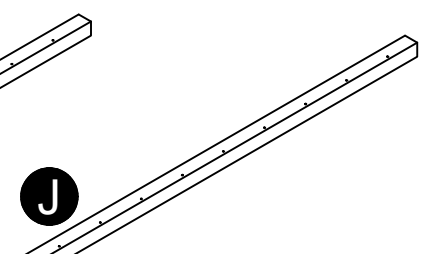

Right Rear Leg
34836344100

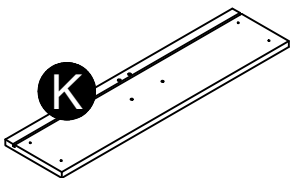

Upper Drawer Front
34836344110

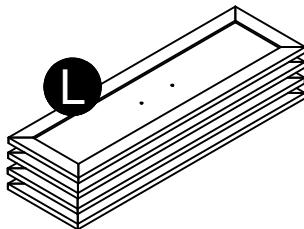

Drawer Front Assembly (4)
34836344120

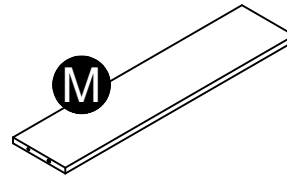

Stringer
34836000130

Board Identification

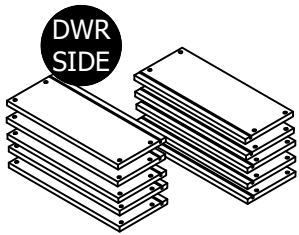

Drawer Side (10)
39991149346200C

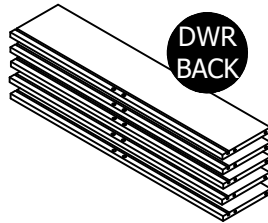

Drawer Back (5)
39991149066250B

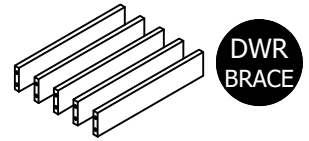

Drawer Brace (5)
399900643295100

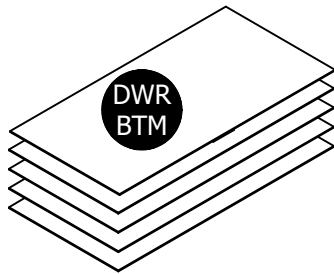

Drawer Bottom (5)
39991341067210D

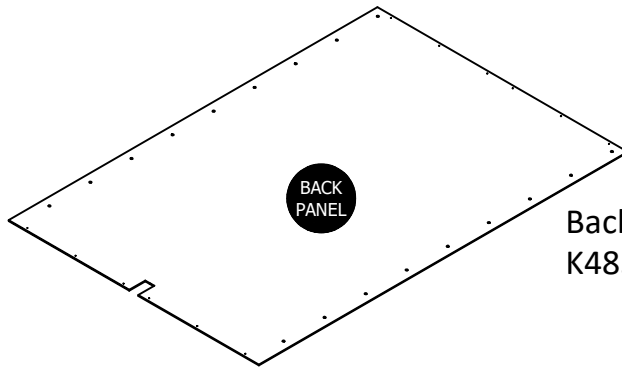

Back Panel
K483600000

This piece is paperboard construction. It is not made from wood, but is required for the assembly of your unit.

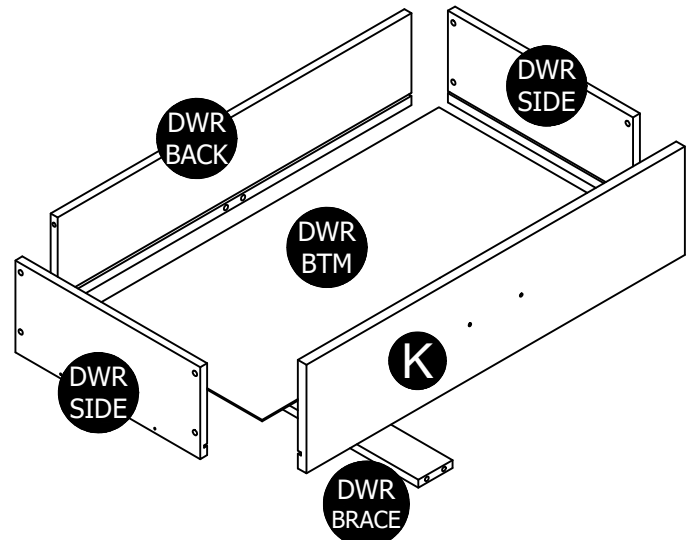
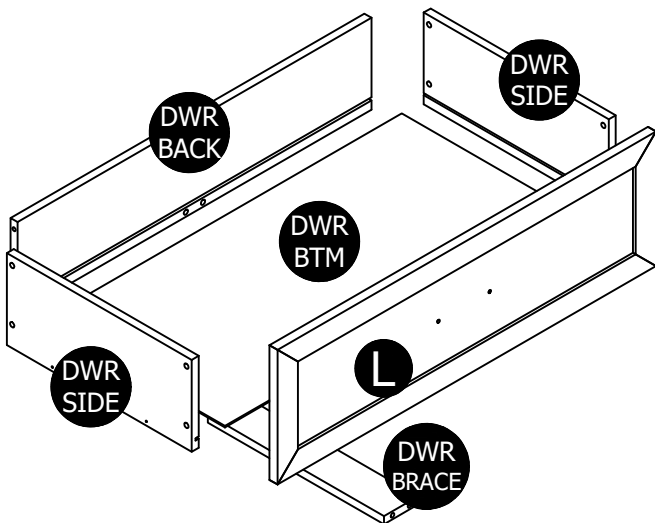

Board Identification

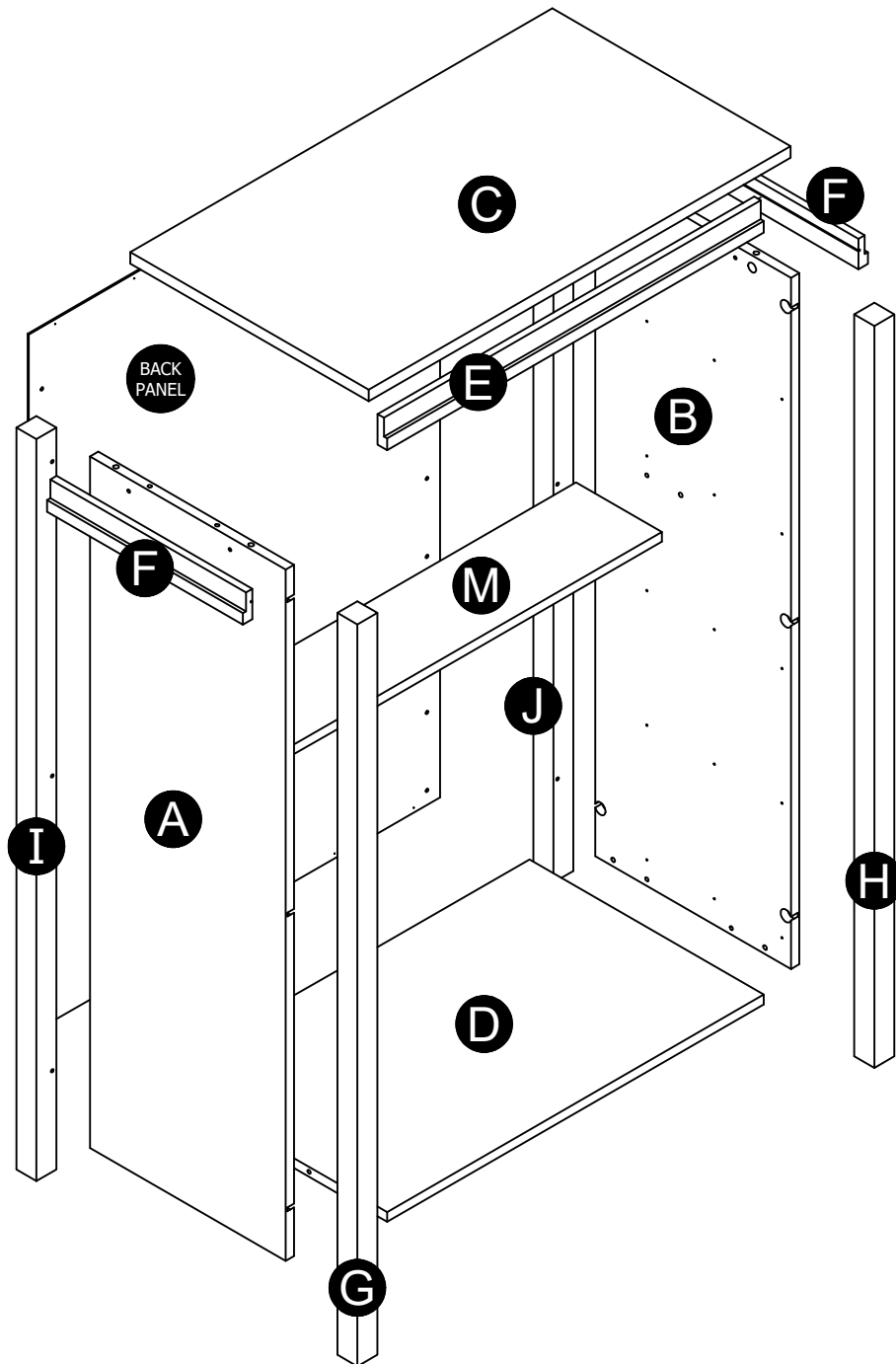

Part List

Actual Size

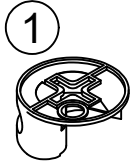

(x20)
#A22620
cam lock

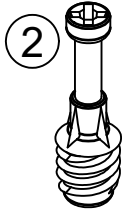

(x20)
#A22610
cam bolt



(x64)
#A12120
7/16" screw

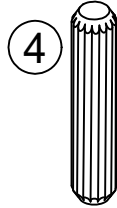

(x10)
#A21660
wood dowel



(x50)
#A11080
7/16" screw



(x12)
#A22910
connector bolt

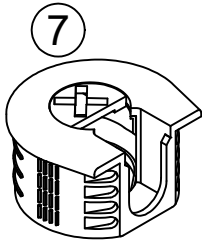

(x12)
#A22930
connector

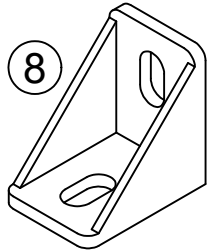

(x3)
#A53510
angle bracket

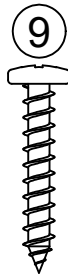

(x4)
#A12810
#8 x 1" screw



(x8)
#A17030
5/16" bolt

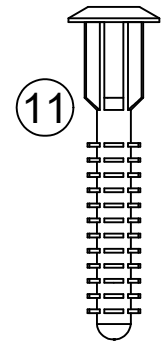

(x30)
#A21970
drive fastener

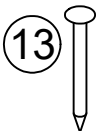

(x12)
#A21110
nail

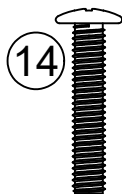

(x2)
#A17400
7/8" bolt

Part List

Not actual size

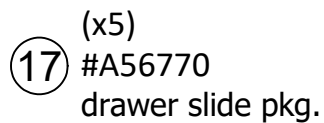
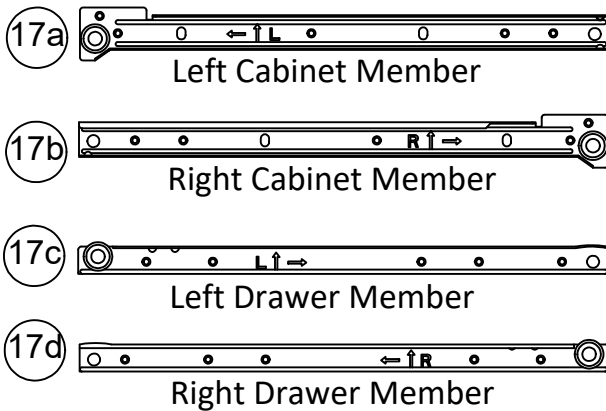
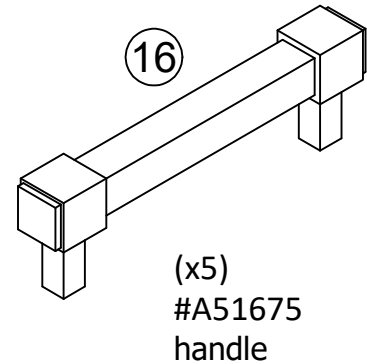
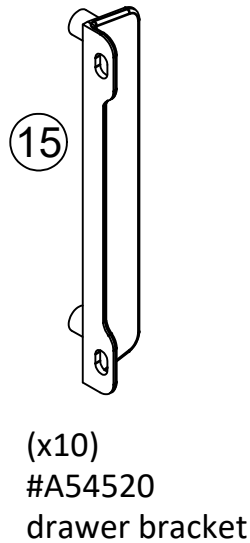
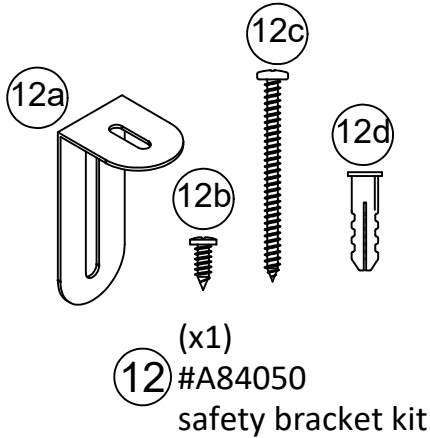

STEP 1

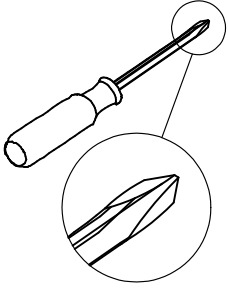

6
(x12)
#A22910

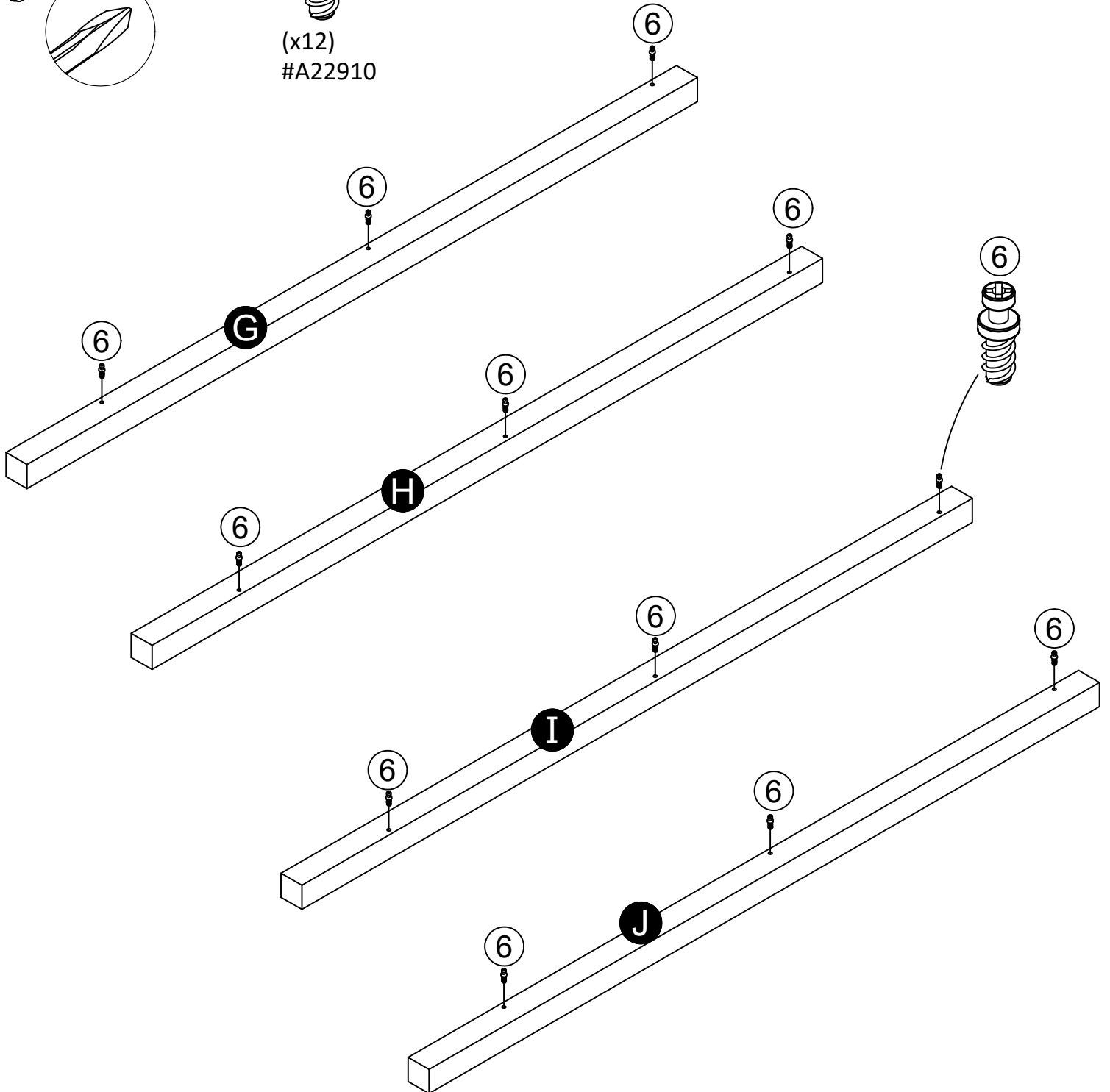

STEP 2

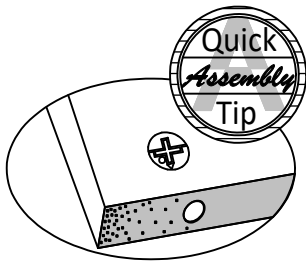
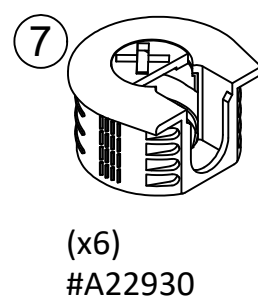
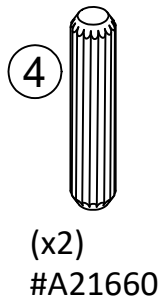
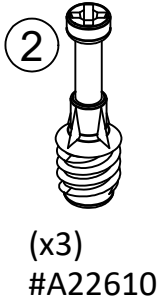
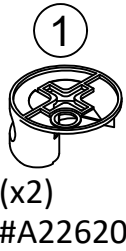
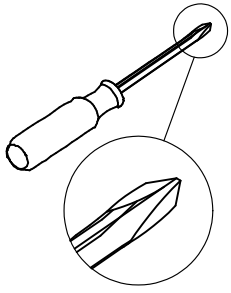

Proper orientation of CAM LOCK

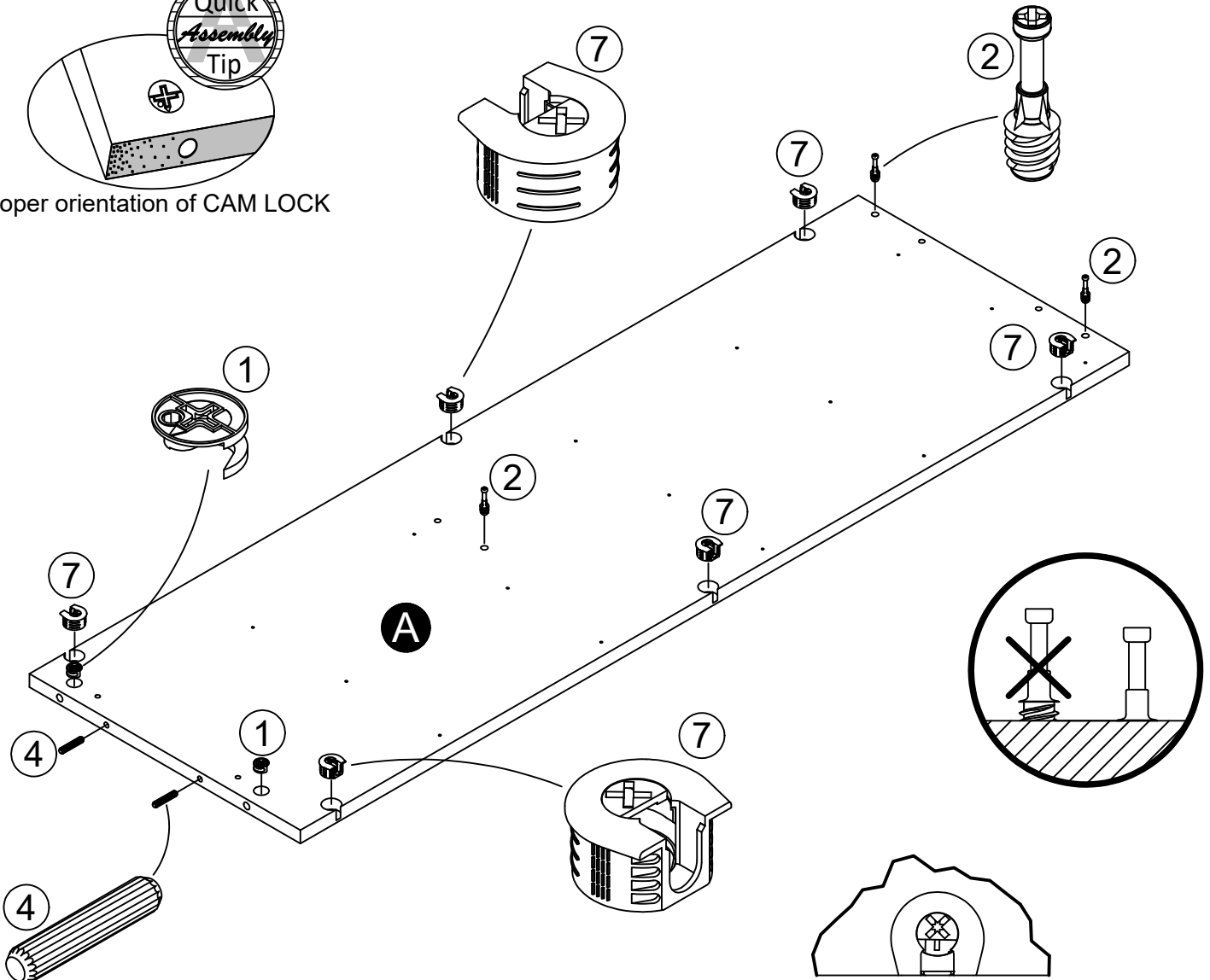

You will need to tap the connector with a hammer to fully insert. Be sure the connector is position as shown before tapping into hole.

STEP 3

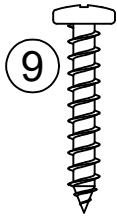
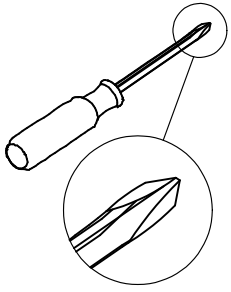

(x2)
#A12810

Attach the legs (G / I) first and then the side rail (F).

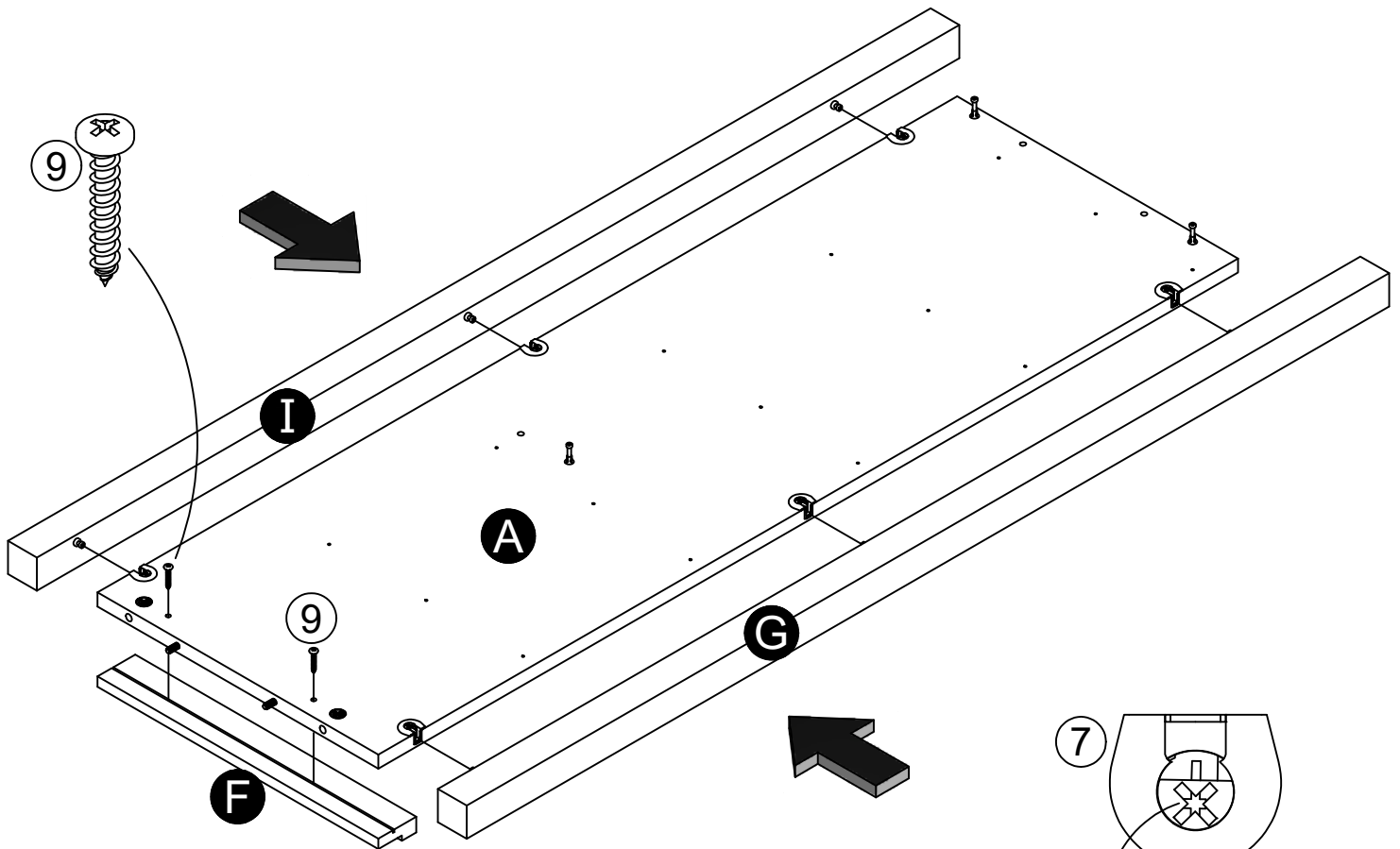

No not overtighten screws (9)
No apriete demasiado los tornillos (9)
Ne serrez pas trop les vis (9)

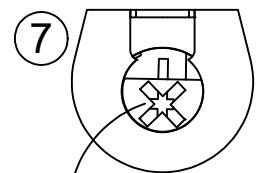

Turn screw clockwise to lock in place.

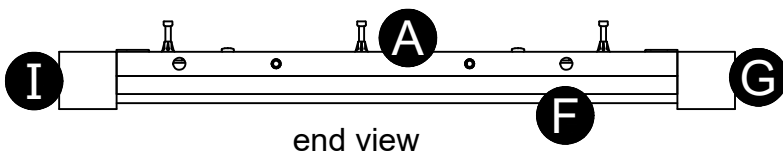

STEP 4

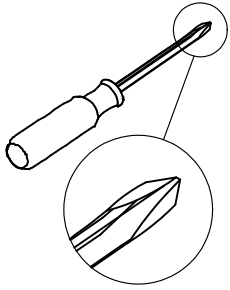

5
(x15)
#A11080

17a
Left Cabinet Member
(x5)
#A56770

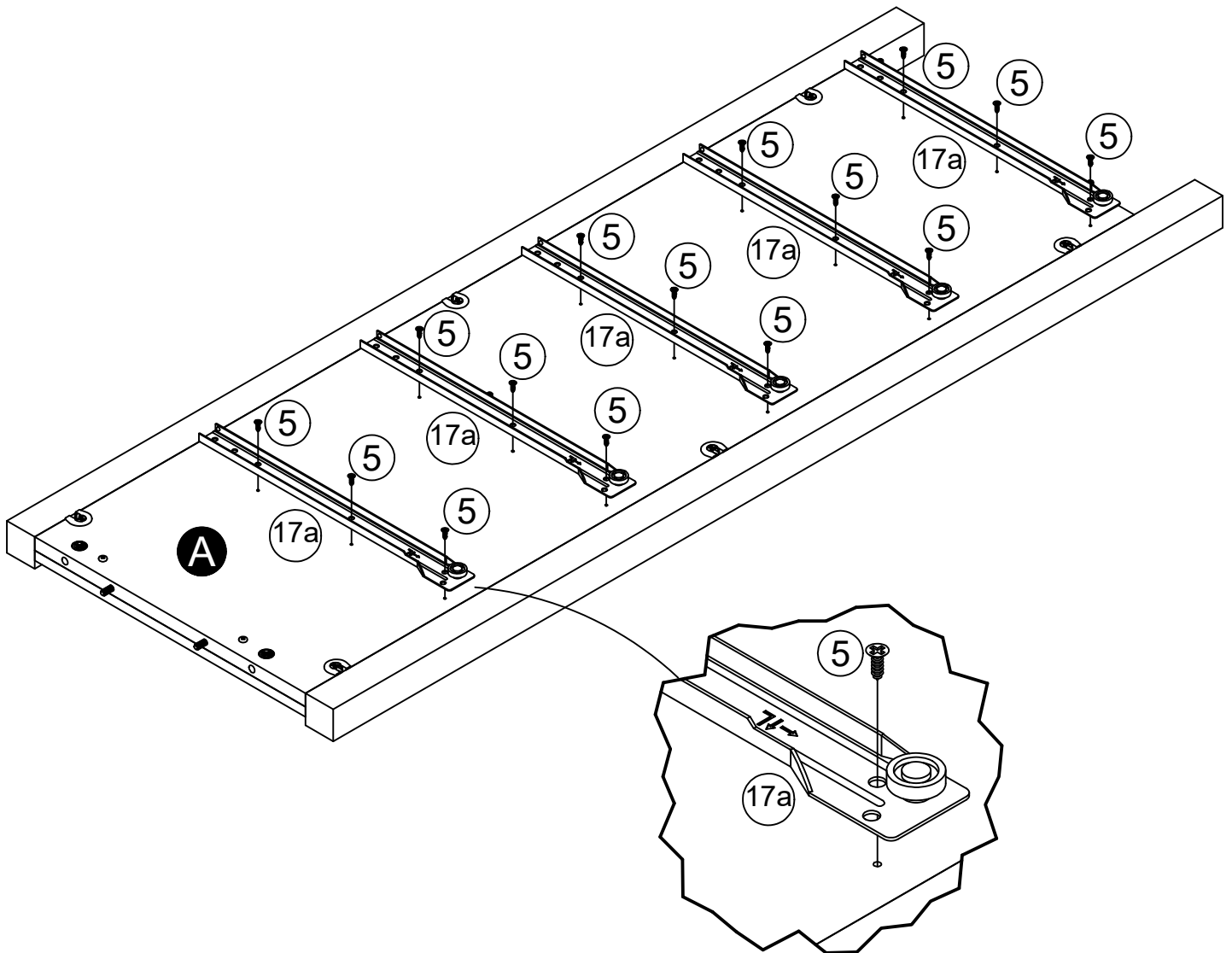

STEP 5

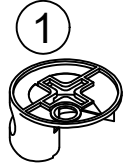
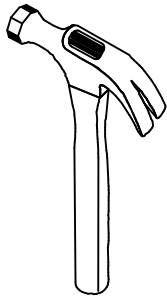
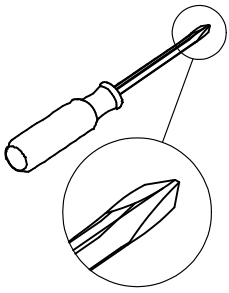

(x2)
#A22620

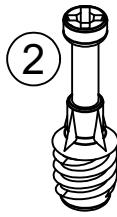

(x3)
#A22610



(x2)
#A21660

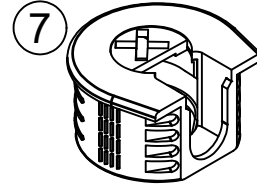

(x6)
#A22930

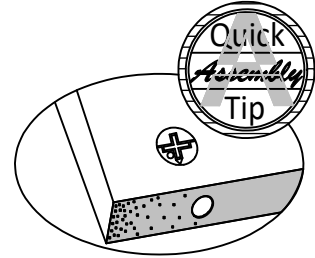

Proper orientation of CAM LOCK

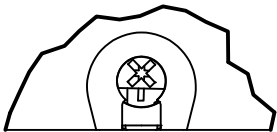
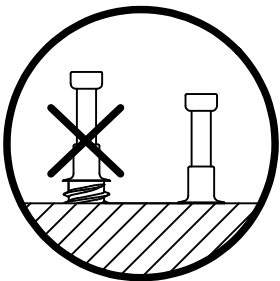
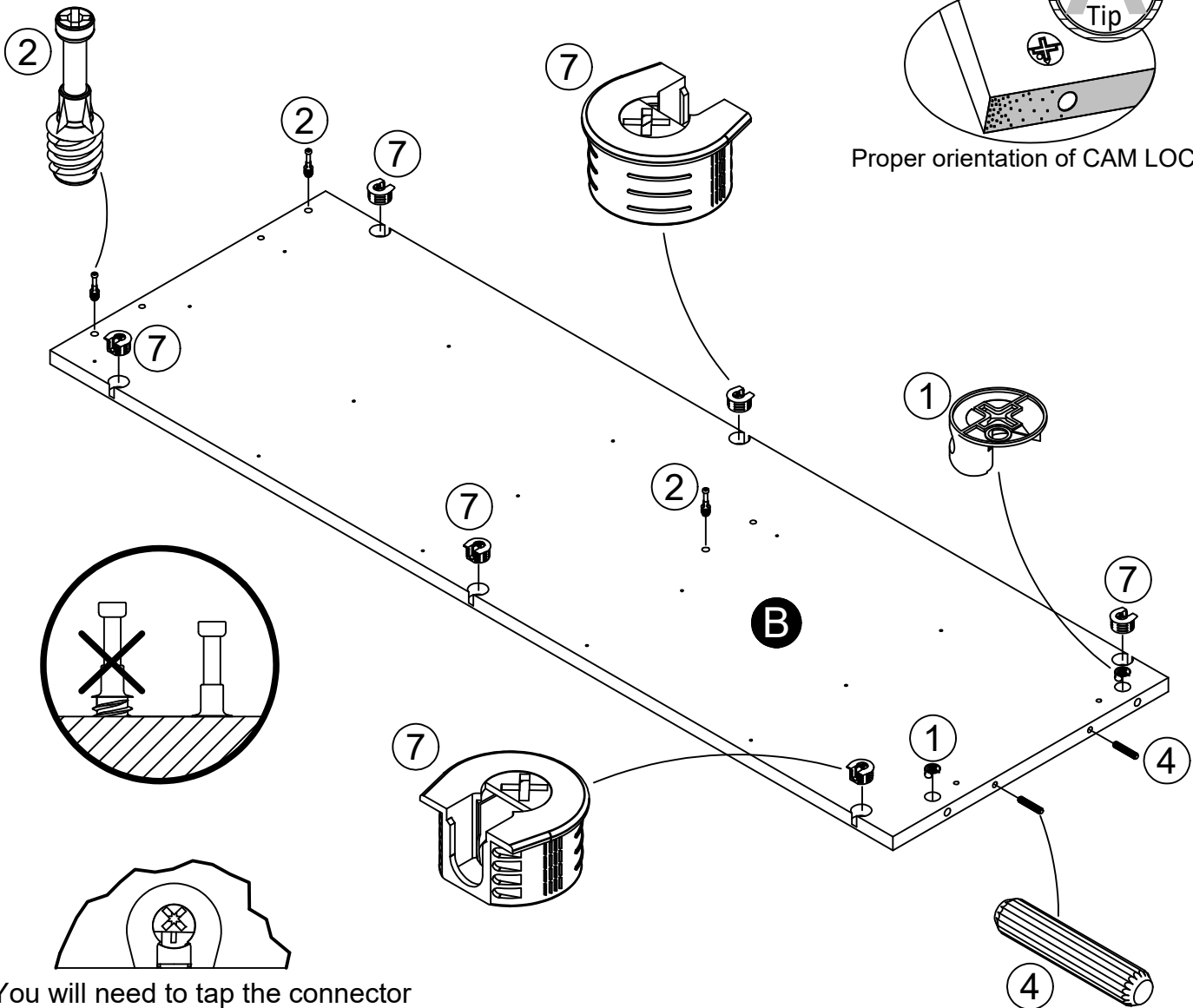

You will need to tap the connector with a hammer to fully insert. Be sure the connector is position as shown before tapping into hole.

STEP 6

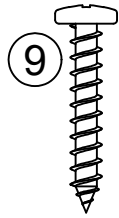
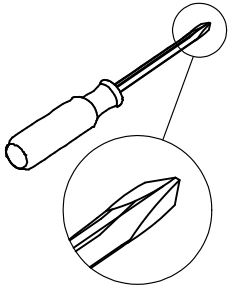

(x2)
#A12810

Attach the legs (H / J) first and then the side rail (F).

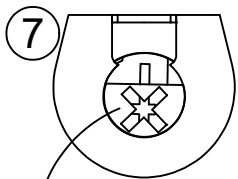
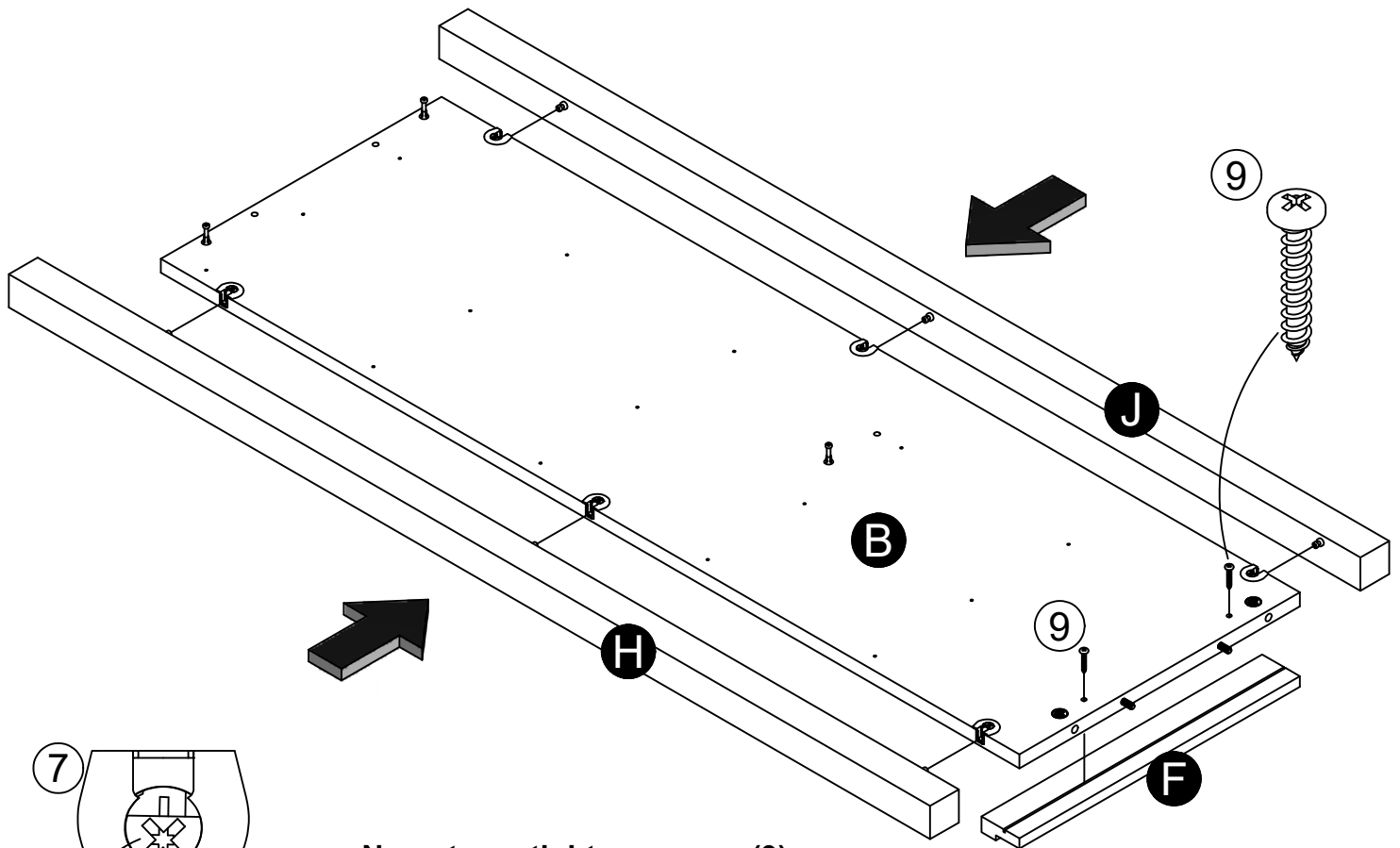

Turn screw clockwise to lock in place.

No not overtighten screws (9)
No apriete demasiado los tornillos (9)
Ne serrez pas trop les vis (9)

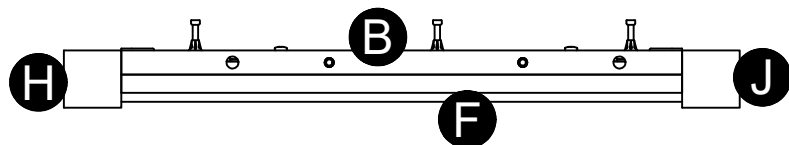

end view

STEP 7

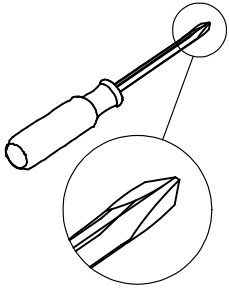

5
(x15)
#A11080

17b
Right Cabinet Member
(x5)
#A56770

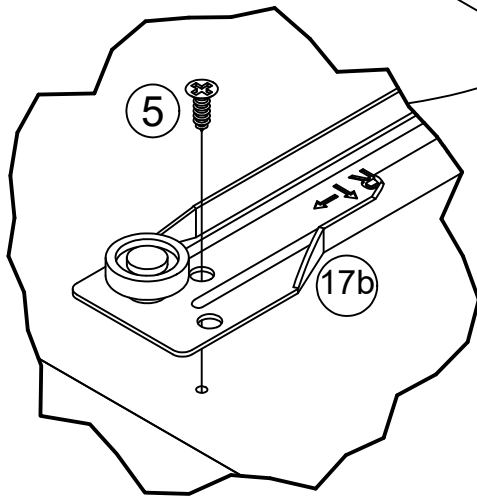
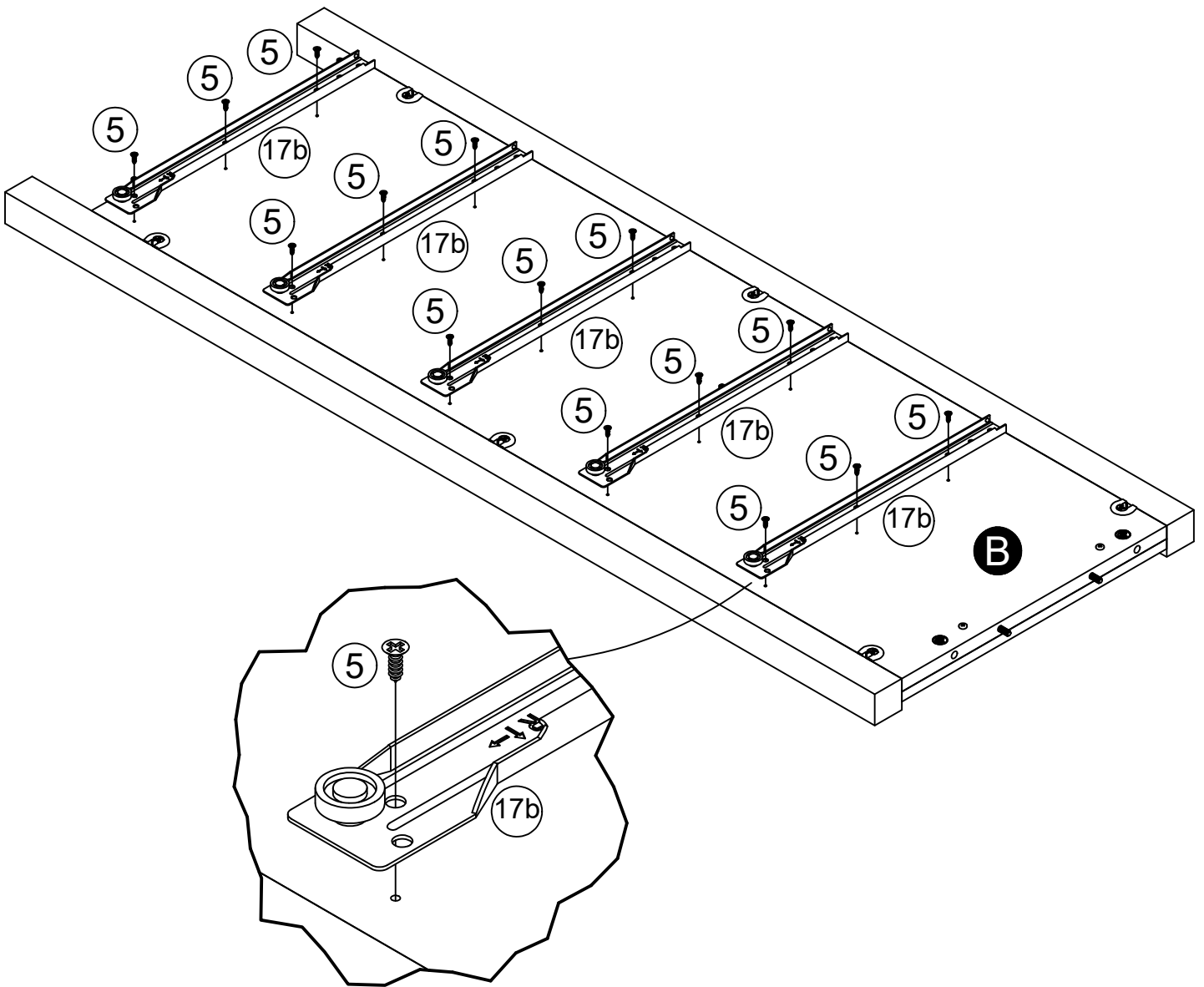

STEP 8

1
(x6)
#A22620

4
(x6)
#A21660

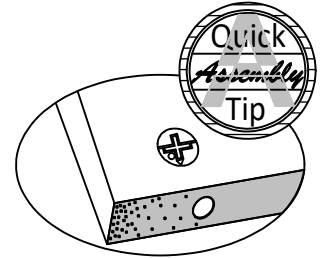

Proper orientation of CAM LOCK

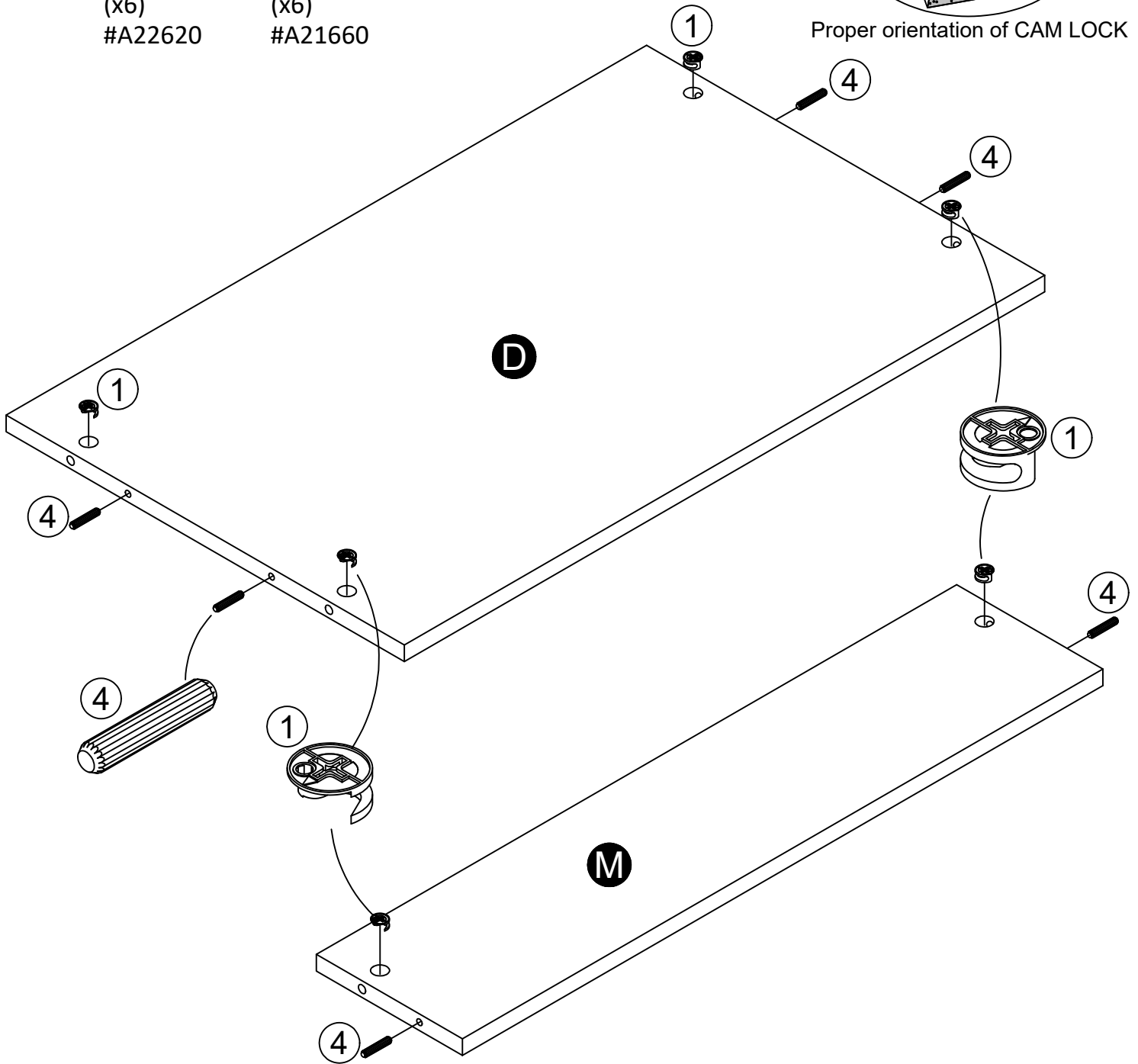

STEP 9

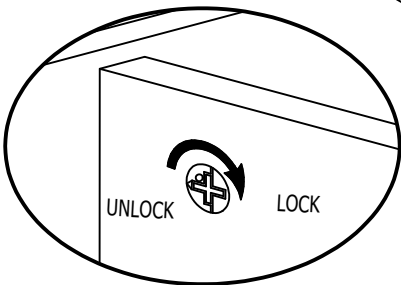
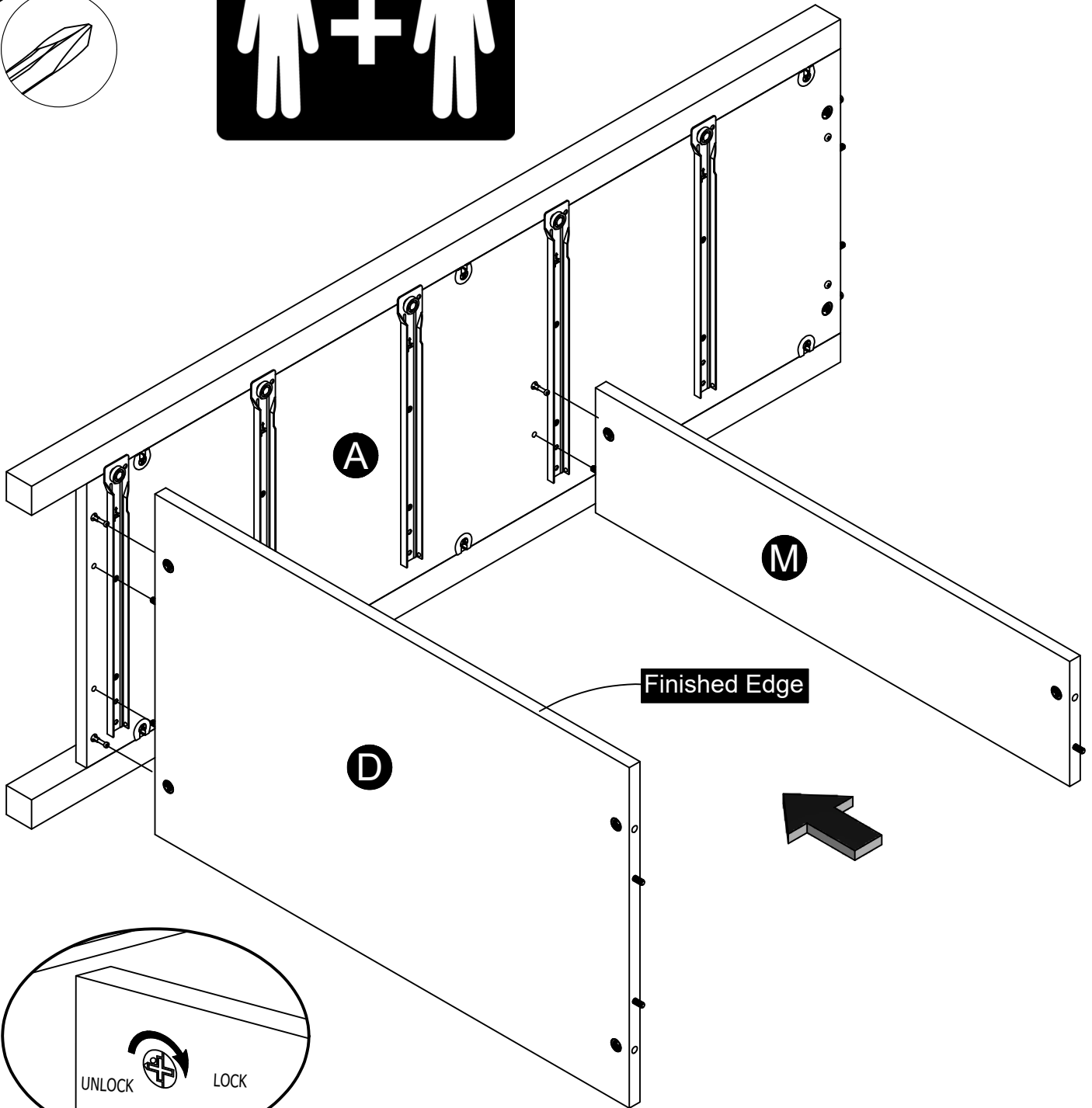
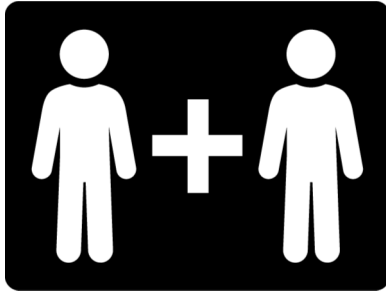
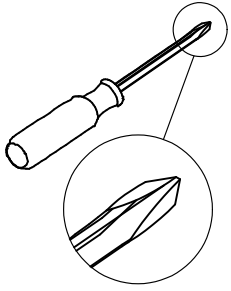

STEP 10

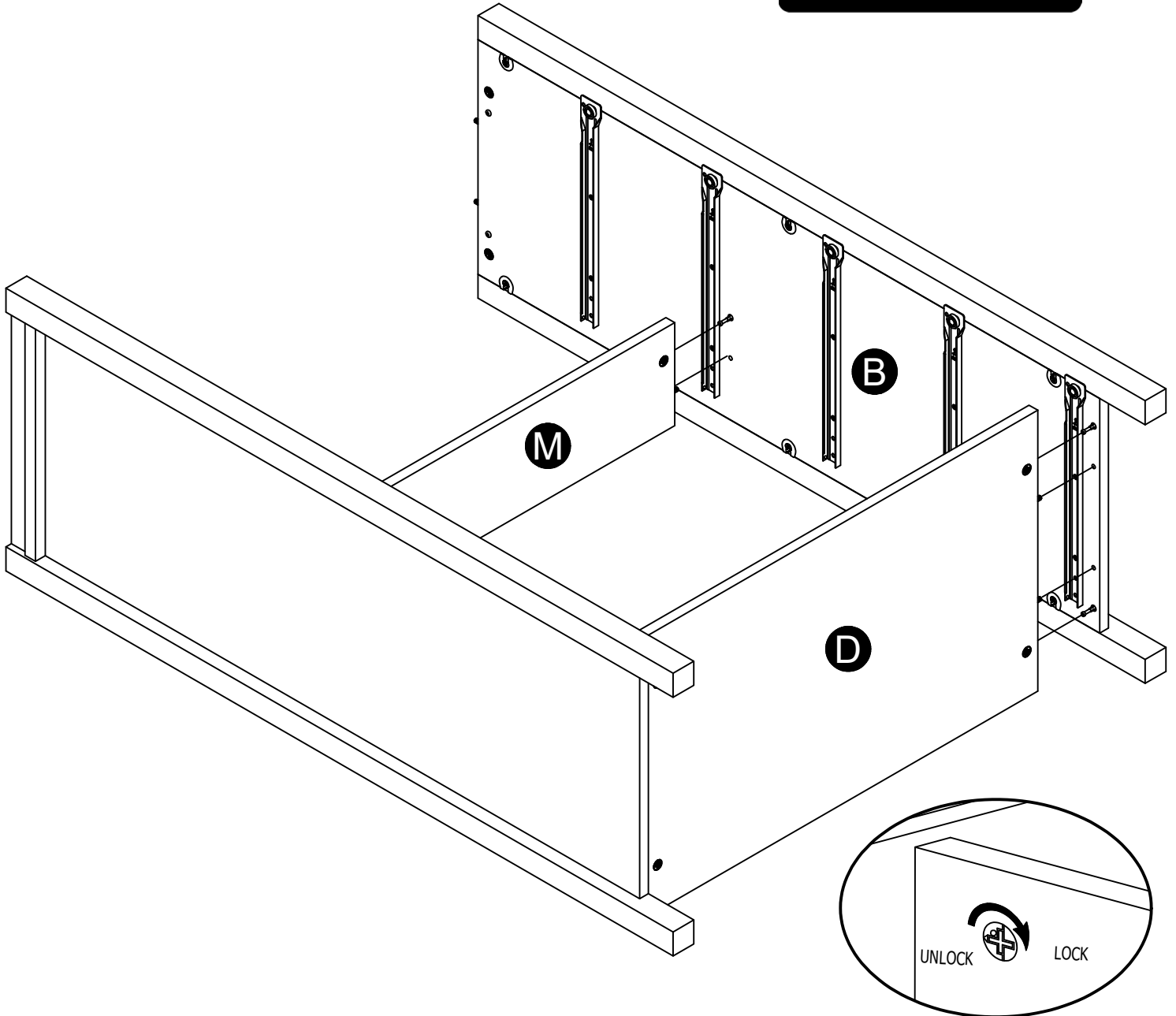
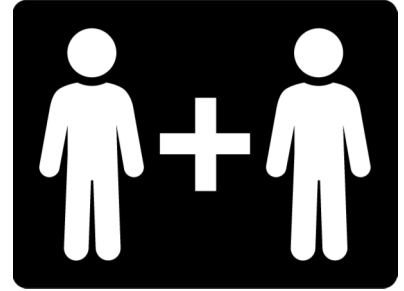
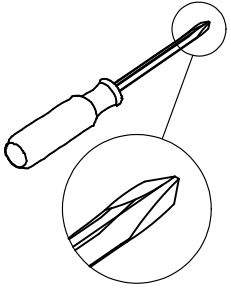

STEP 11

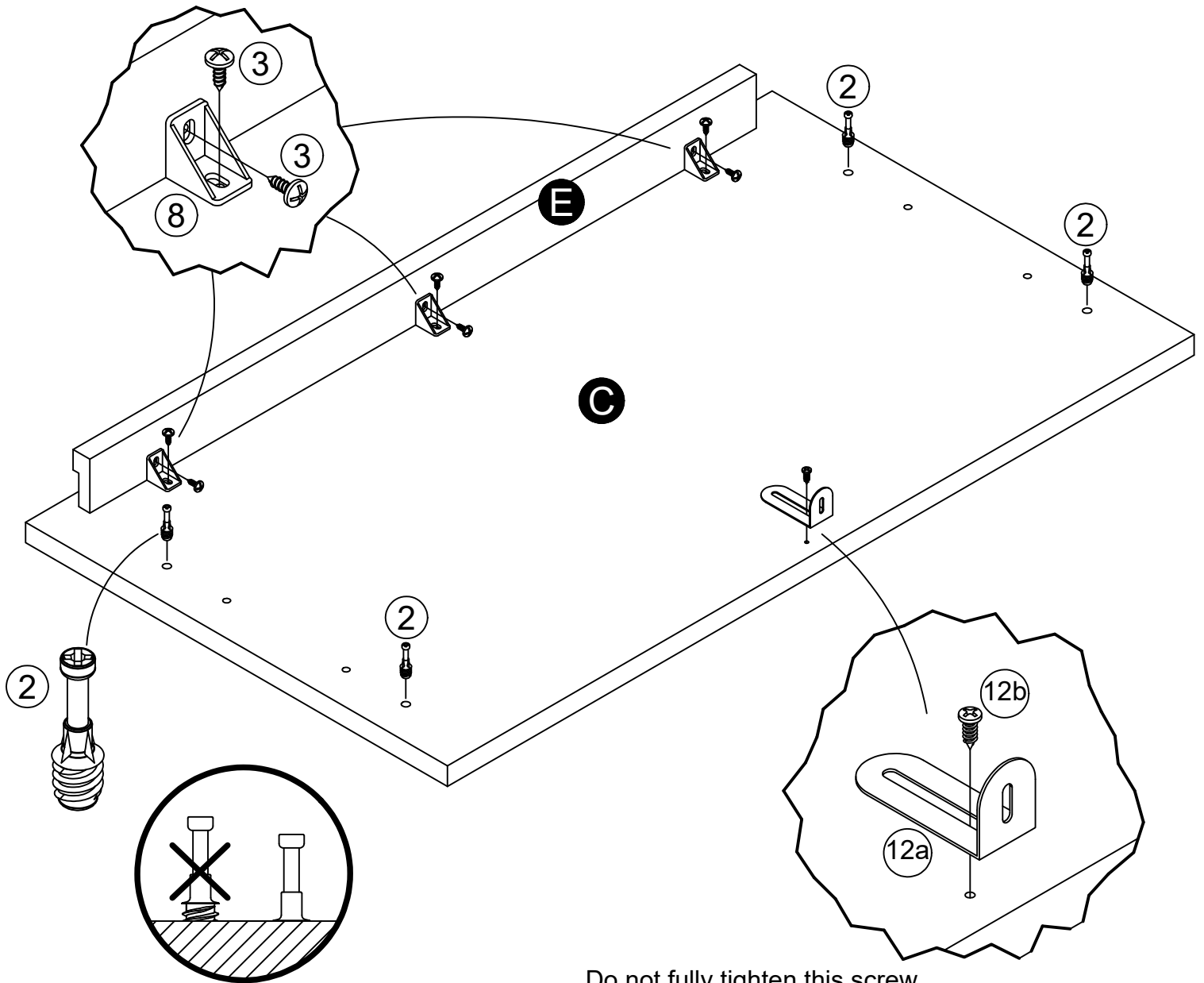
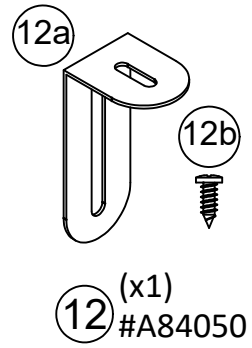
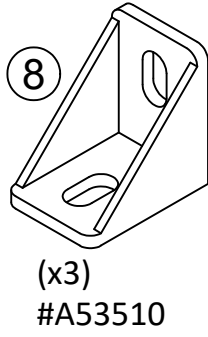
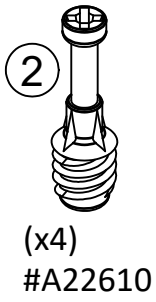
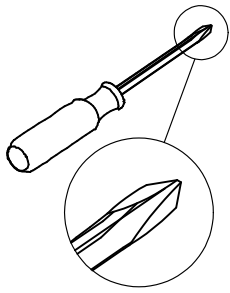

Do not fully tighten this screw.

STEP 12

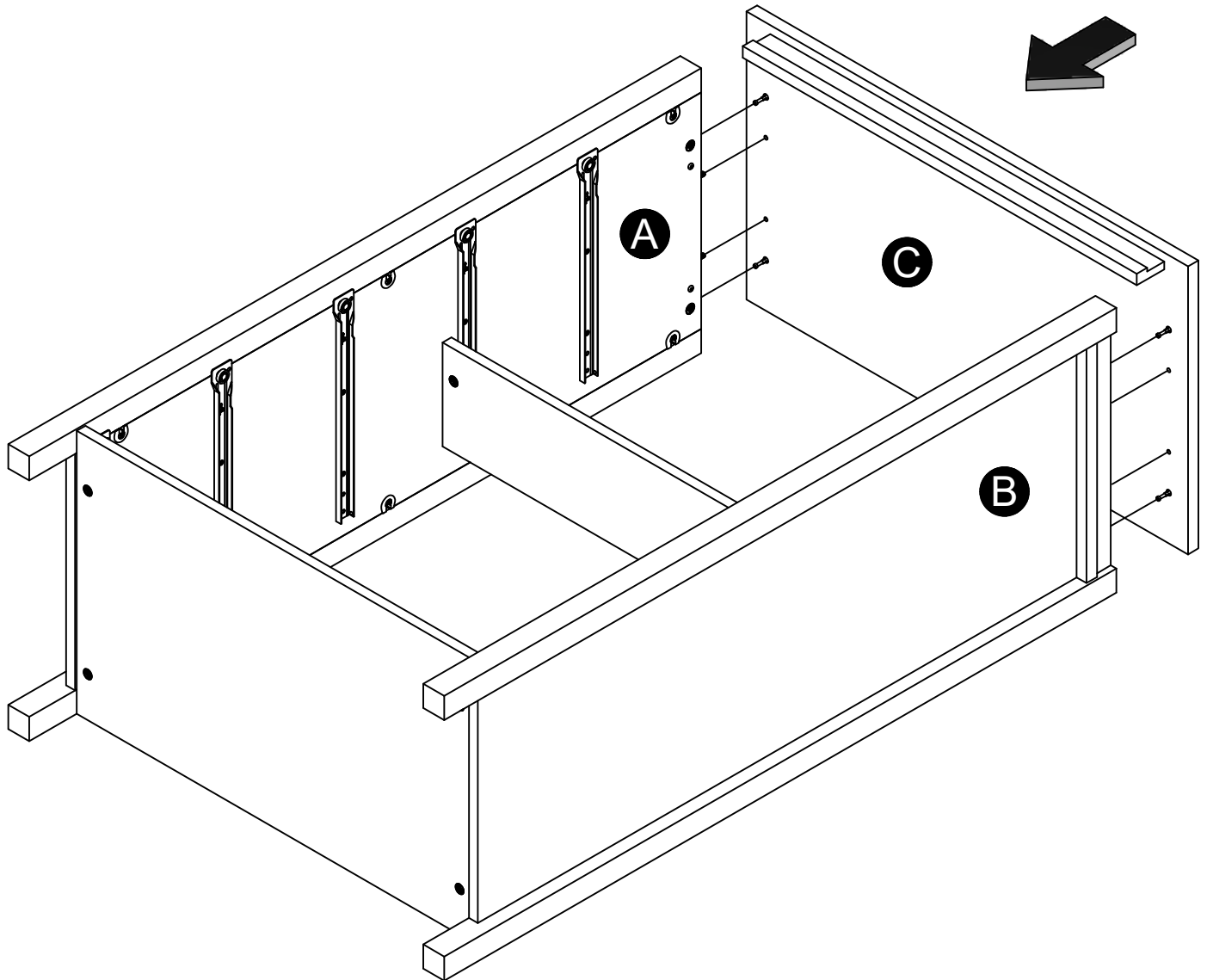
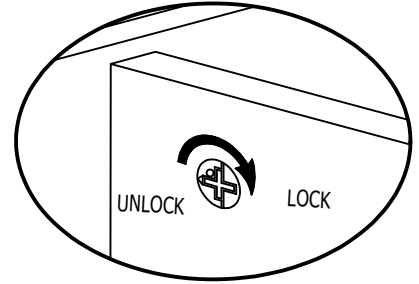
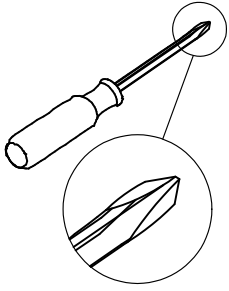

STEP 13

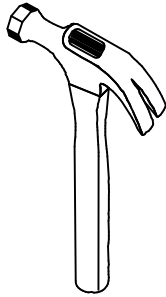
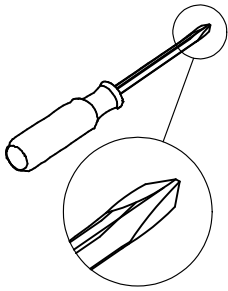

(x18)
#A12120

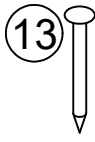

(x12)
#A21110

IMPORTANT! THE BACK PANEL IS A STRUCTURAL PART OF THIS UNIT AND MUST BE INSTALLED PROPERLY.

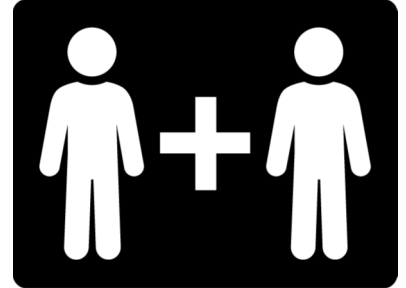

Attached the back panel as shown nailing straight into the raw edges.
Assure that the unit is square.
Distance from corner to corner must be equal.

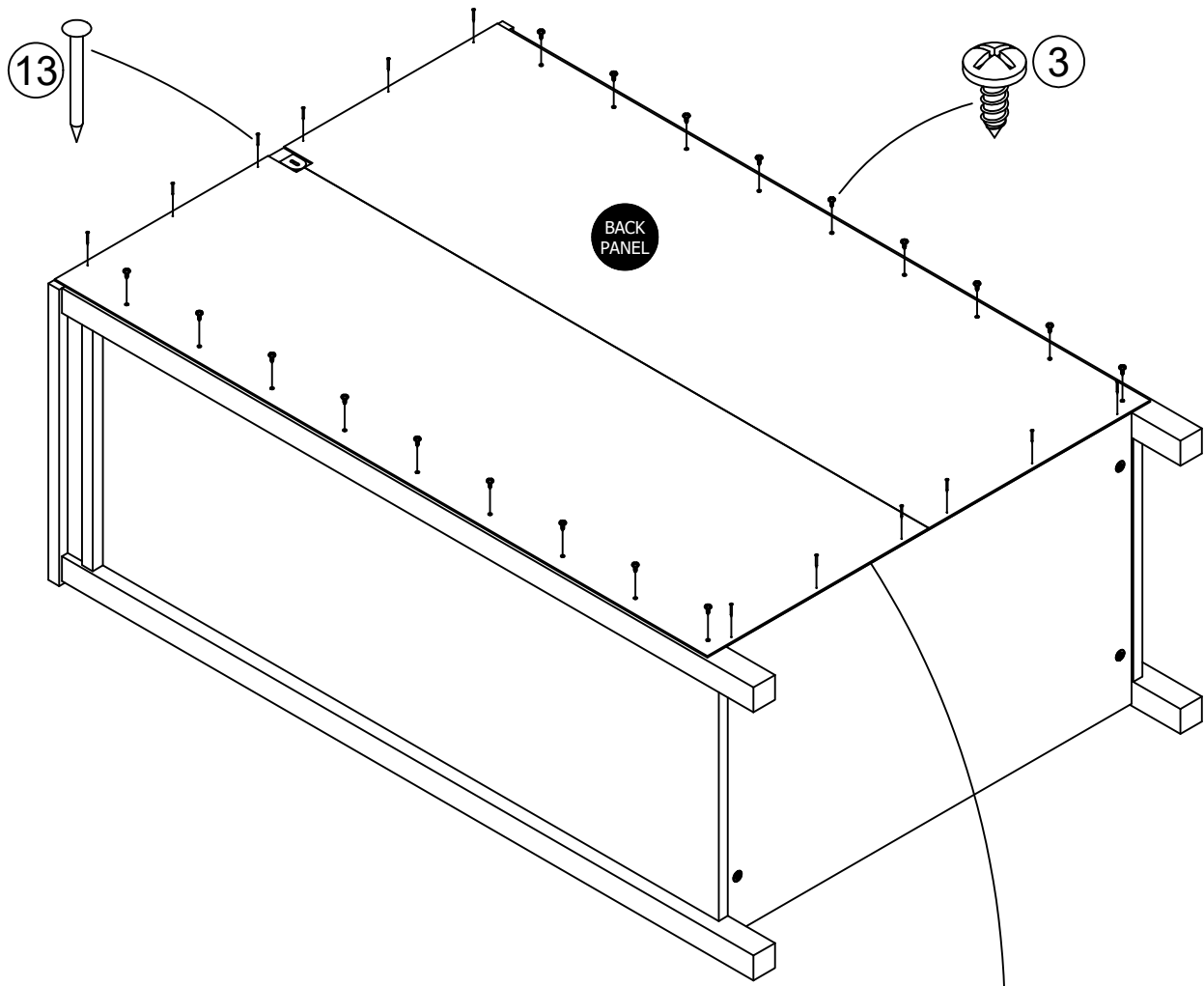

Bottom edge of back panel will be flush with bottom of bottom shelf.

STEP 14

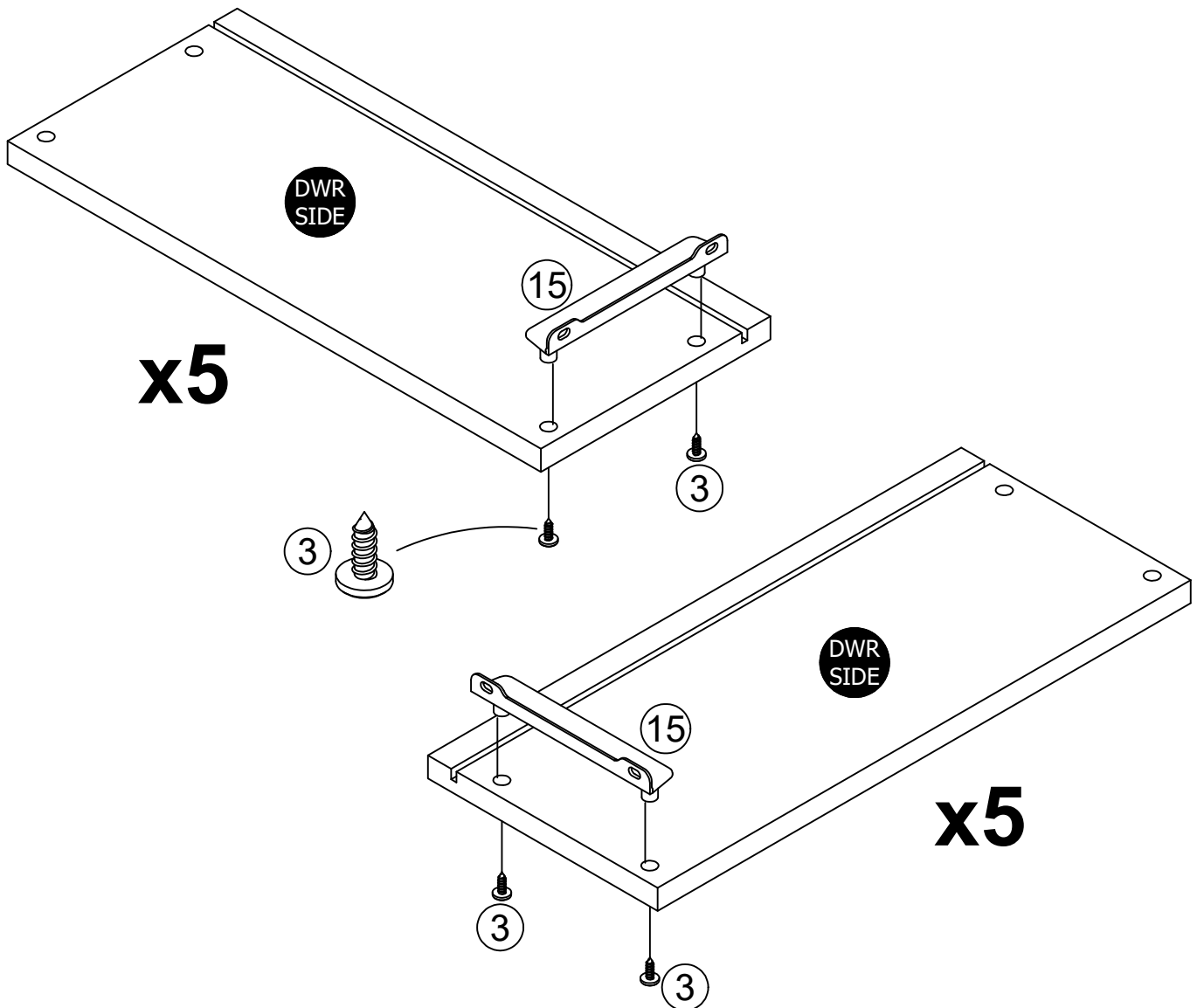
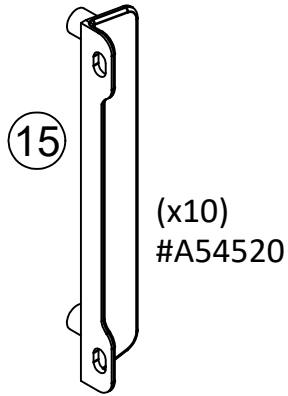
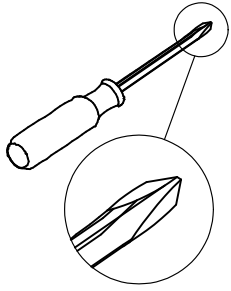

STEP 15

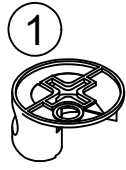
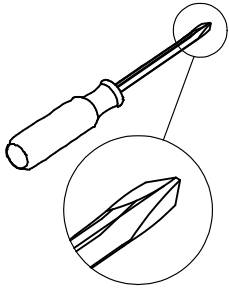

(x10)
#A22620

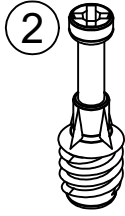

(x10)
#A22610

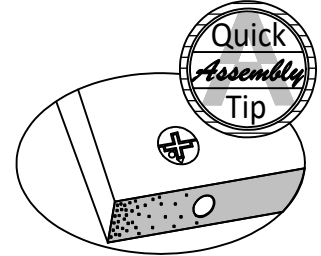

Proper orientation of CAM LOCK

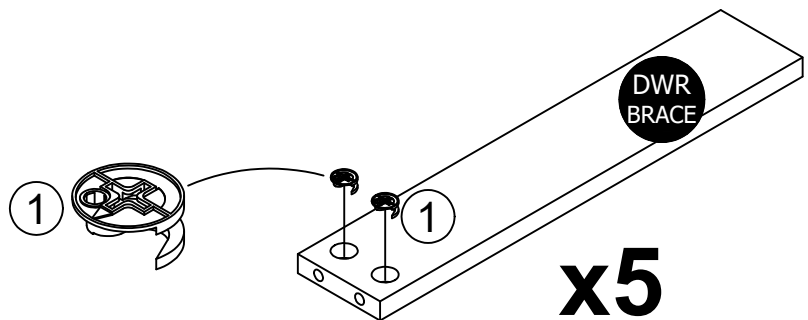
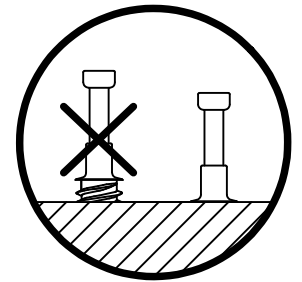
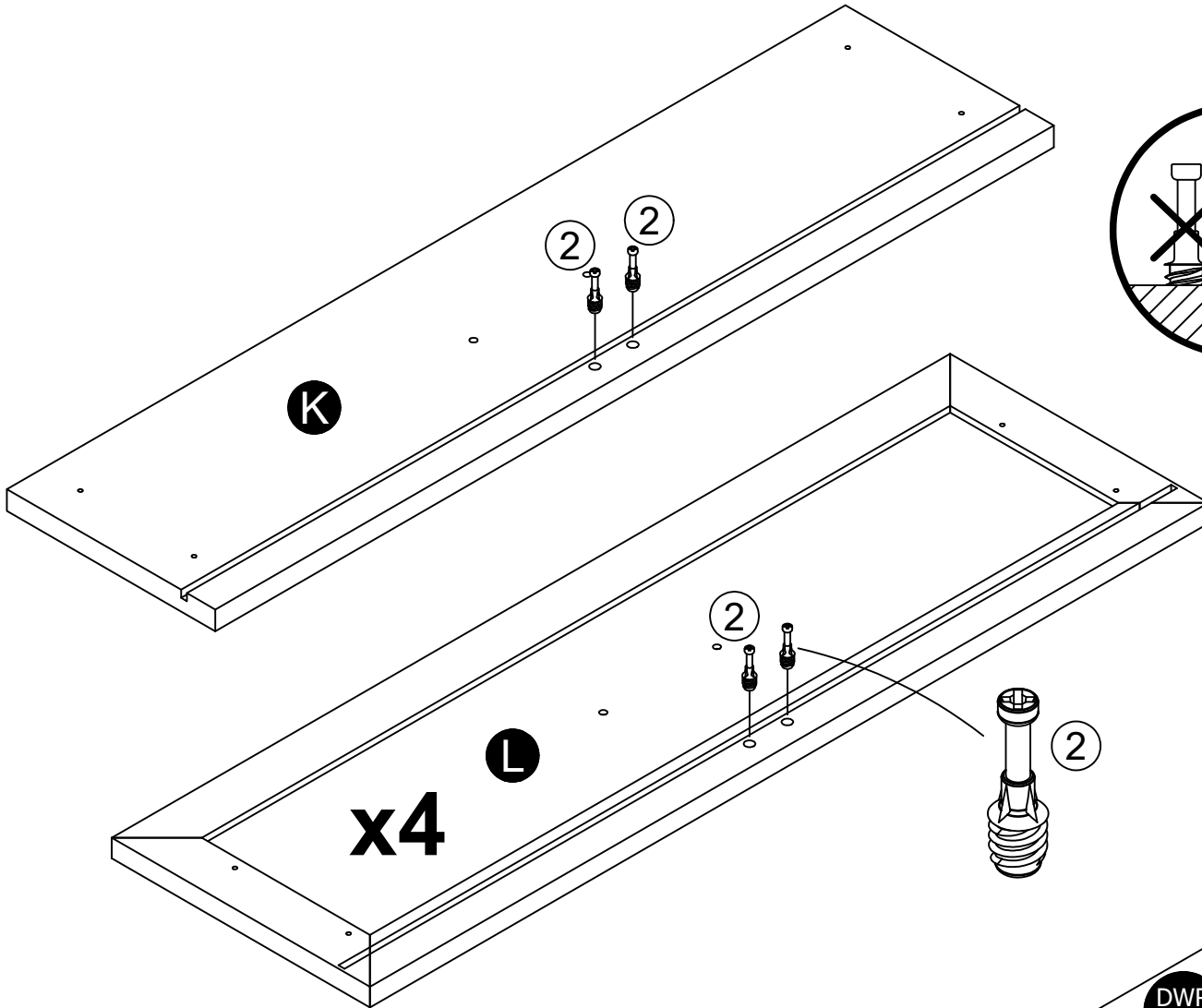

STEP 16

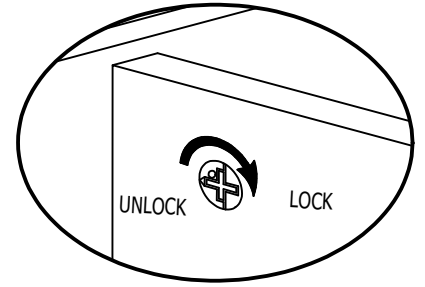
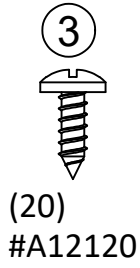
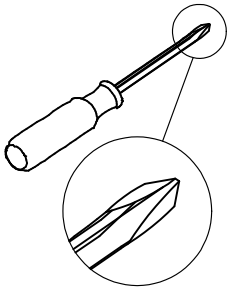

Note:
All drawers assemble the same.

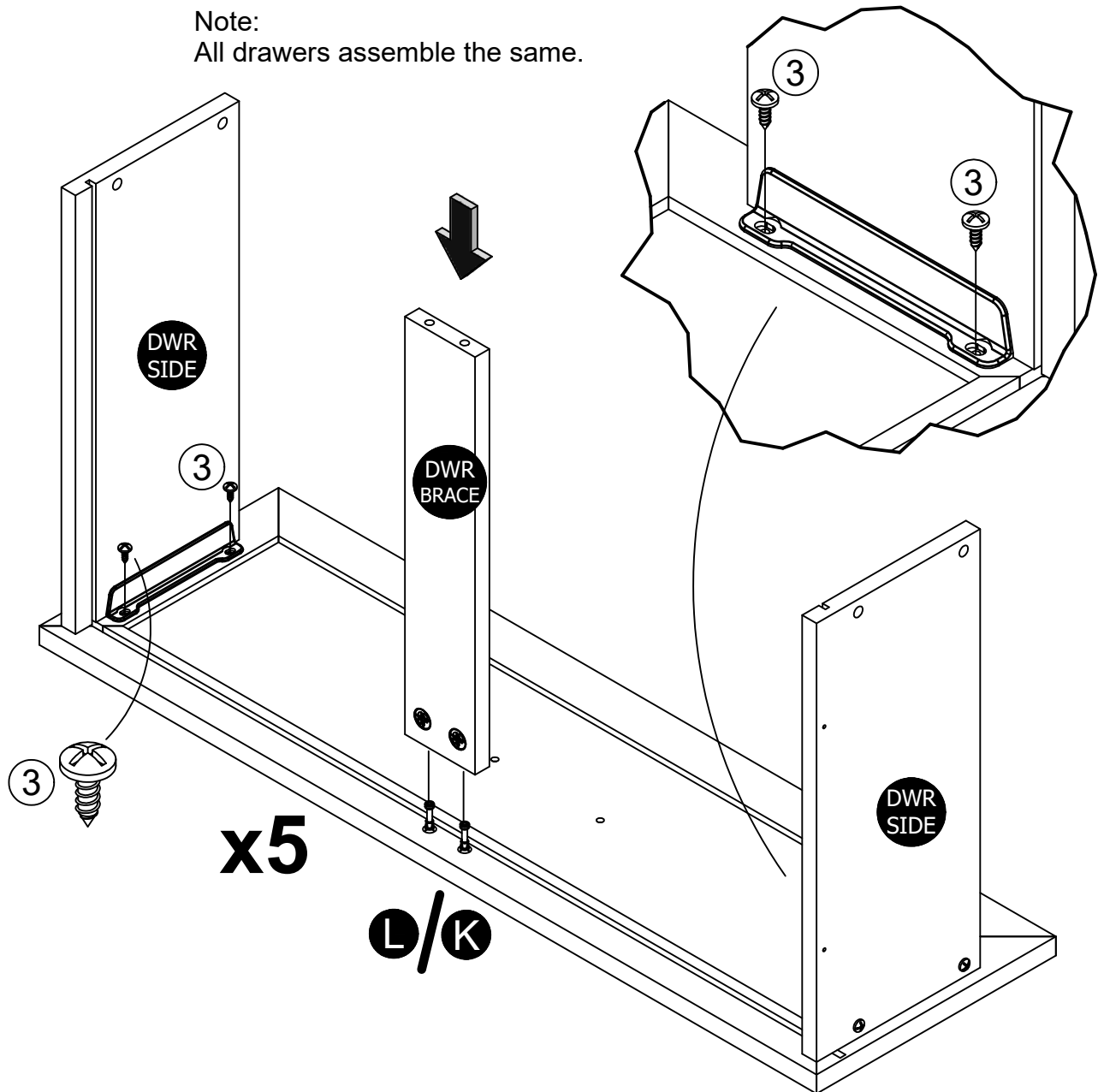

STEP 17

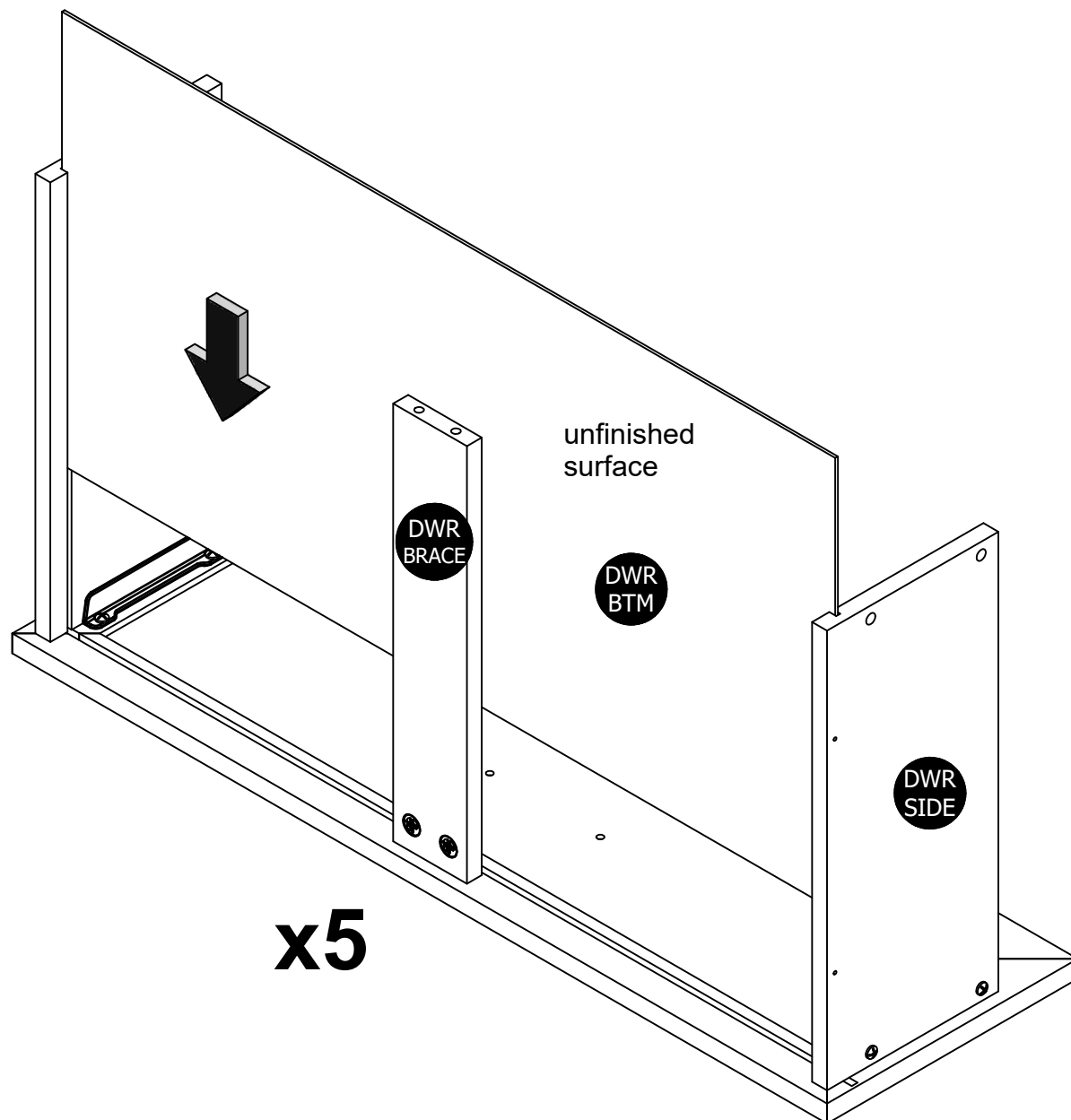

STEP 19

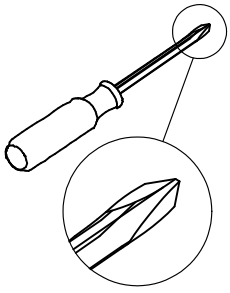

5
(x20)
#A11080

10
(x8)
#A17030

14
(x2)
#A17400

17c

17d

(x5)
#A56770

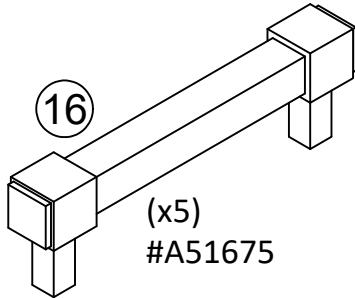

Attach the slides first and then the handle.

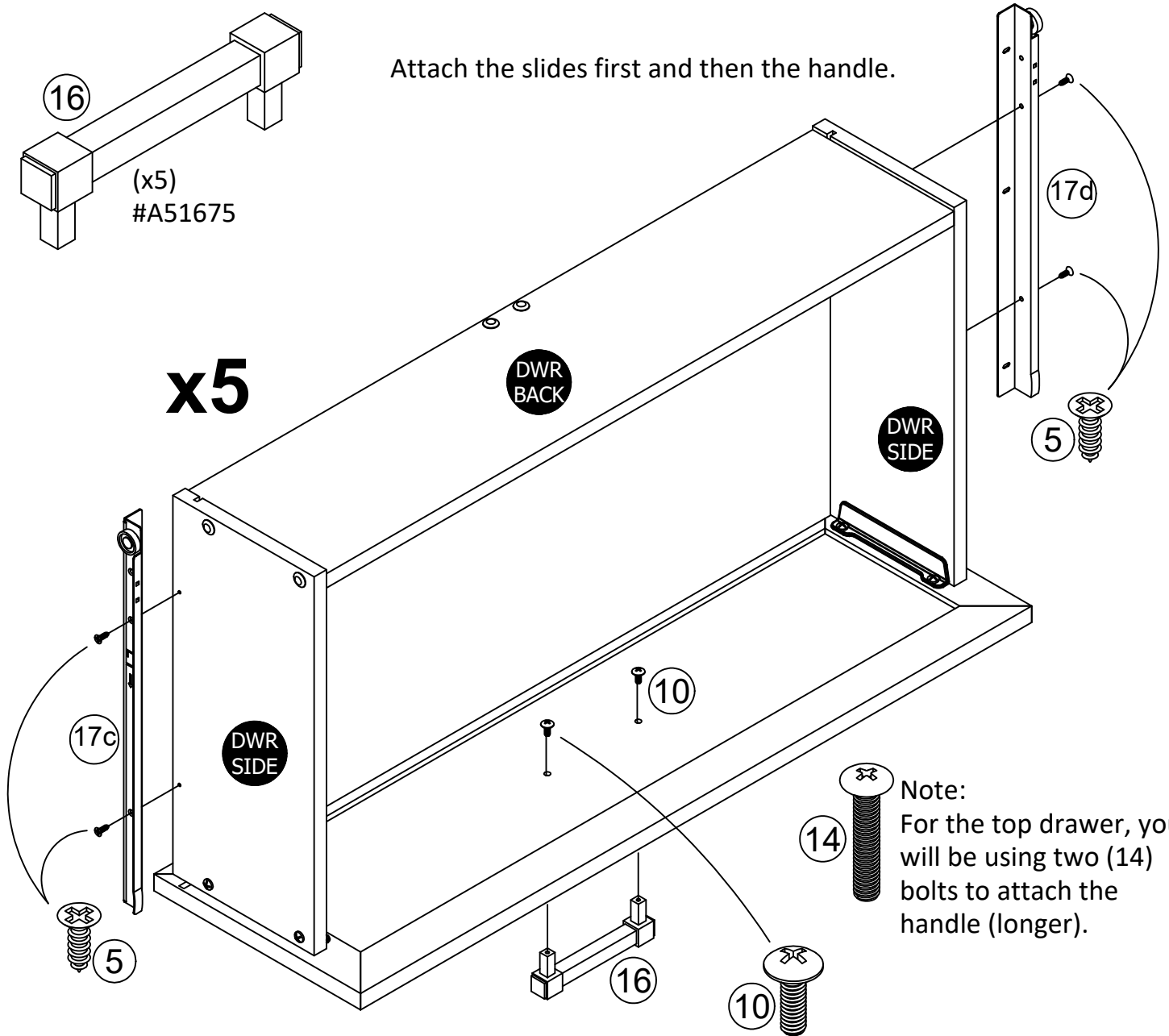

STEP 20

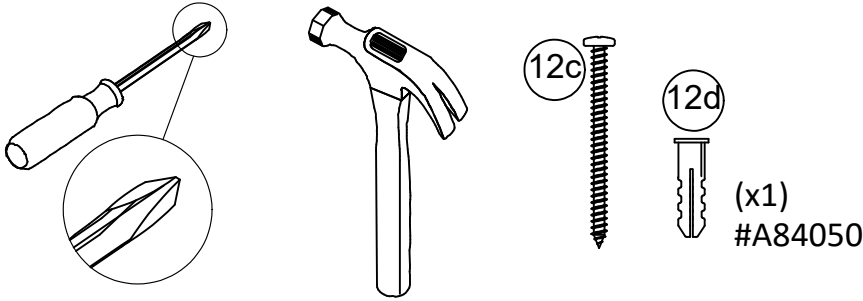

For Masonry, Concrete, or other wall materials:
Consult your local hardware store for appropriate anchors to securely attach the safety bracket.

IMPORTANT: THIS UNIT MUST BE SECURE TO THE WALL TO HELP PREVENT TIPOVER. FOLLOW THESE INSTRUCTIONS TO INSTALL THE ANTI-TIPPING SAFETY BRACKET PROVIDED WITH THIS PRODUCT.

OPTION 1: Attachment into a wall stud (preferred method)

Using a stud finder, locate a stud in the wall. Place your unit against the wall, with the safety bracket aligned in this location. To make driving the screw easier, you can drill a 1/8" diameter pilot hole (3mm) through the safety bracket into the stud. Drive the screw through the safety bracket into the wall stud. Tighten the screw that was not fully tightened in step 11.

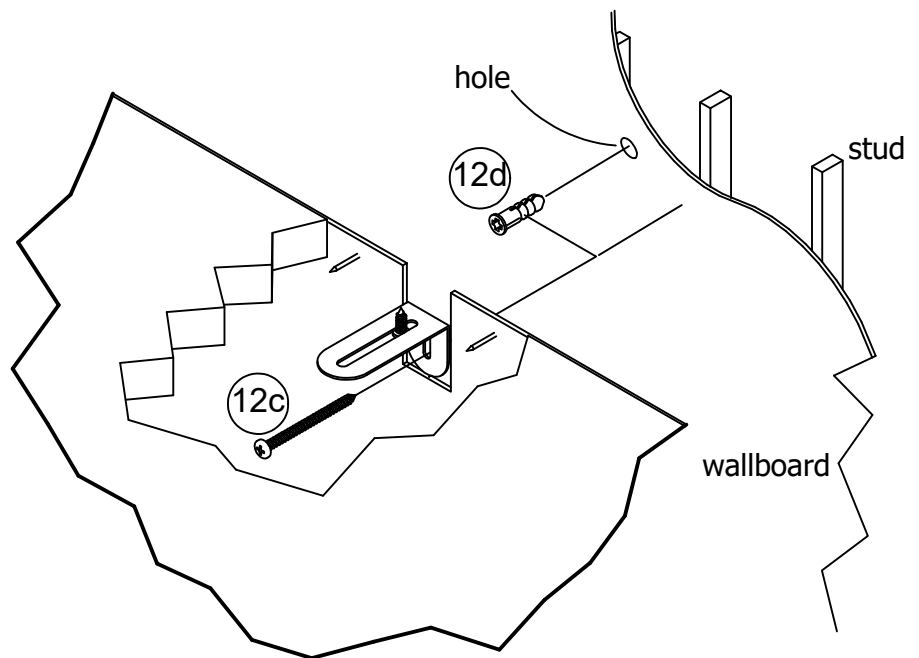

OPTION 2: Attachment into drywall

Locate your unit where desired against a wall and mark the wall through the safety bracket, then move your unit aside. Drill a 3/16" diameter hole (5mm) into the wallboard. Tap the wall anchor into the hole until it is flush. Move your unit into location and fasten the wall bracket to the wall anchor with the screw. Tighten the screw that was not fully tightened in step 11.

⚠ WARNING	
	<p>Children have died from furniture tip over. To reduce the risk of furniture tip over:</p> <ul style="list-style-type: none"> • ALWAYS install tip over restraint provided. • NEVER put a TV on this product. • NEVER allow children to stand, climb or hang on drawers, doors, or shelves. • NEVER open more than one drawer at a time. • Place heaviest items in the lowest drawers.

STEP 21

Note: The drawer bracket holes are slotted. Drawer fronts can be adjusted by loosening screws, making needed adjustments and retightening screws.

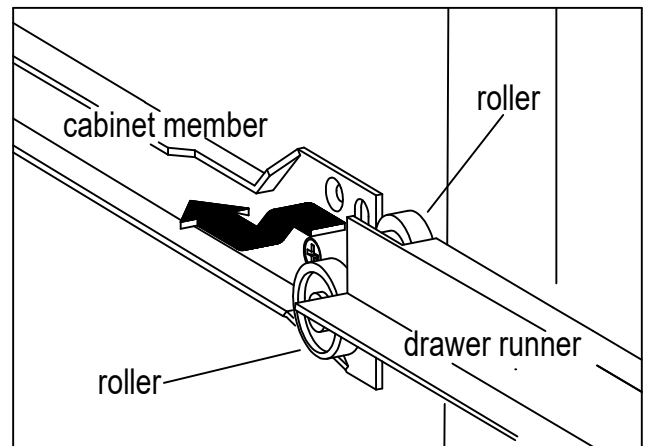
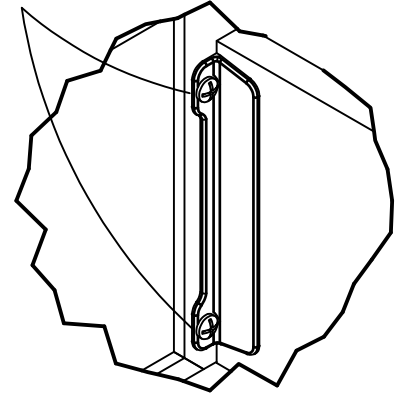
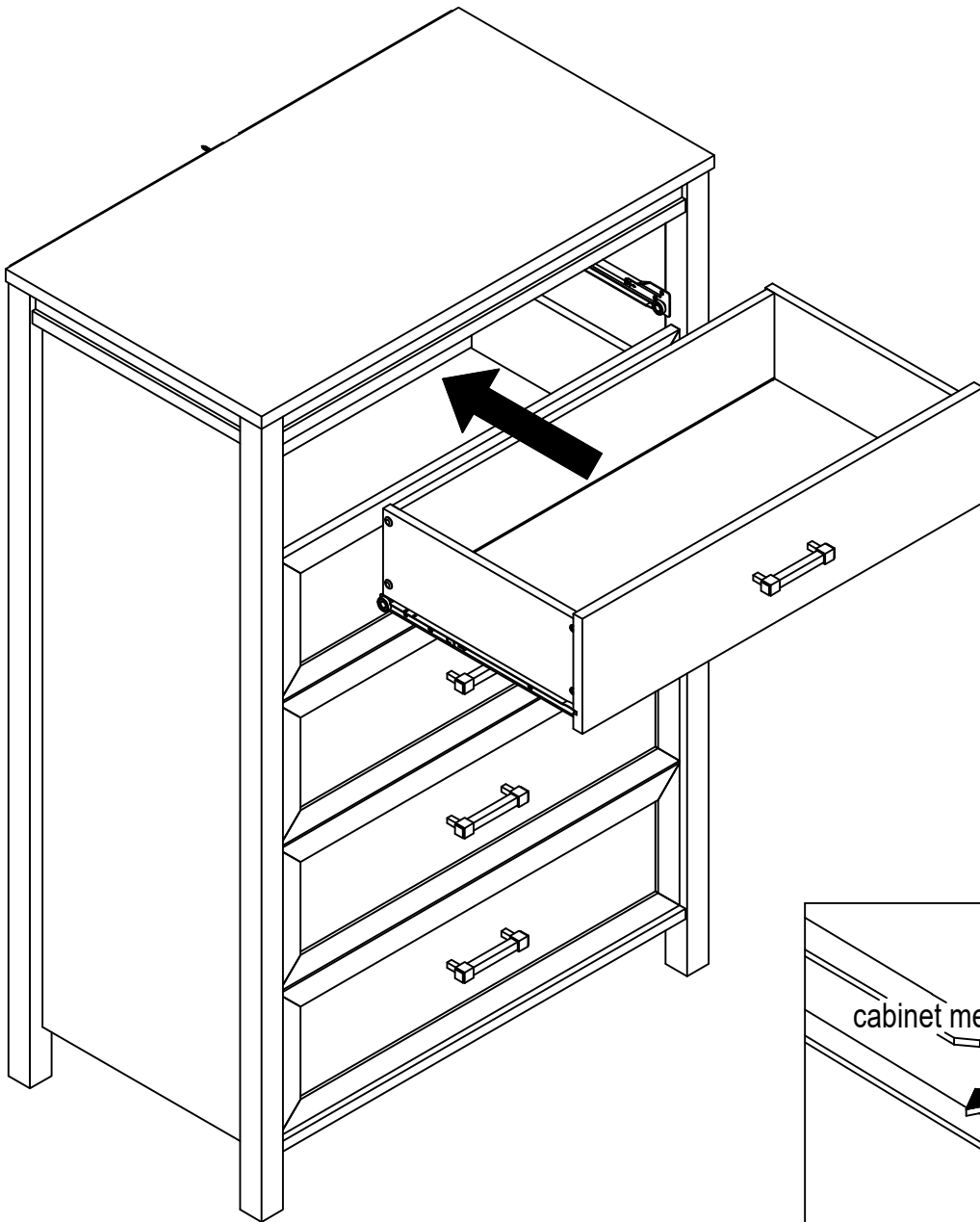

Maximum Loads

This unit has been designed to support the maximum loads shown. Exceeding these load limits could cause sagging, instability, product collapse, and/or serious injury.

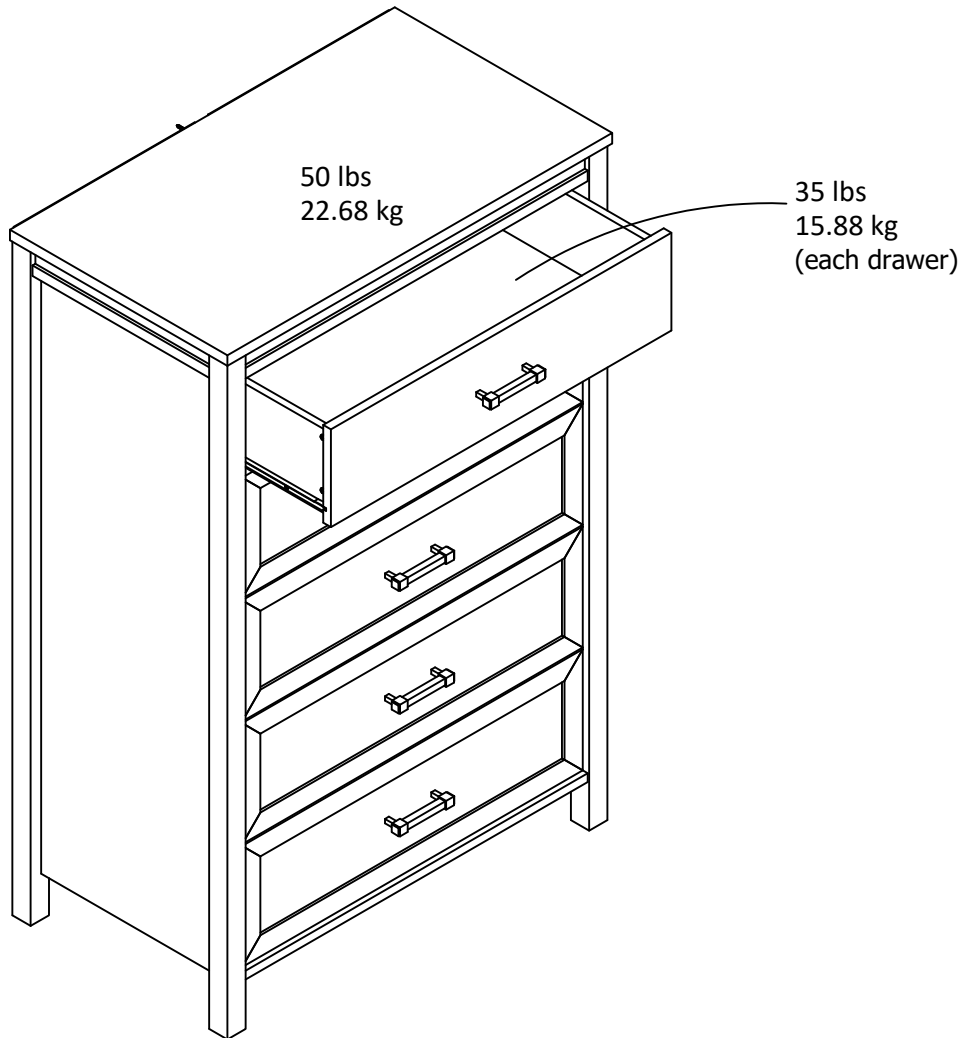

Warning: Risk of injury to persons - do not place a television on this furniture. This furniture is not approved for use with a television.

Certificate of Conformity

1. This certificate applies to the Dorel Home Furnishings, Inc. product identified by this instruction manual.
2. This certificate applies to compliance of this product with the CPSC Ban on Lead-Containing Paint (16 CFR 1303).
3. This product is distributed by: Dorel Home Furnishings, Inc.
410 East First Street South
Wright City, MO 63390
636-745-3351
4. Site of Manufacture: Cornwall ON
5. See front page of instruction manual for date of manufacture.

Register your product to receive the following:



- * New trend details - sneak peek on what's new
- * Surveys - have a voice within our community
- * Exclusive deals and discount codes
- * Quick and easy replacement part service

To register your product, visit ameriwoodhome.com

5 Star Rating



Visit your local retailer's website, rate your purchased product and leave us some feedback!

We would like to extend a big "Thank You" to all of our customers for taking the time to assemble this Ameriwood Home product, and to give us your valuable feedback.

*Thank
You!*

Cubierta Delantera

Este libro de instrucciones contiene información **IMPORTANTE** de seguridad. Por favor lea y manténgalo para referencia en el futuro.

No Regrese este producto! Comuníquese con nuestro amigoso equipo de servicio al cliente para obtener ayuda.

Llámenos al: 1-800-489-3351 (Gratis) Lunes - Viernes 9am - 5pm CST

Visitar: www.ameriwoodhome.com

PRECAUCION

Este mueble puede volcarse y causar graves heridas y/o muerte.

Anclar el mueble a un poste de madera en la pared (si esto se requiere).

No Permita que los niños monten el mueble.

Mantenga los artículos más pesados en los cajones de abajo.

Consejos Útiles (página 2)

- Abra su artículo en el área donde usted planea utilizarlo para evitar levantar y moverlo menos
- Identificar, ordenar y contar las piezas antes de intentar ensamblar
- Las clavijas de compresión se golpean con un martillo
- Las diapositivas están marcadas con una R (derecha) y L (izquierda) para la colocación correcta
- Asegúrese de que siempre este el punto localizado en la parte superior de bloqueador de leva este volteado hacia borde exterior
- Utilizar todos los clavos para el panel de atrás y distribuirlos por igual
- El panel de atrás debe utilizarse para asegurarse de que la unidad quede fija y firme
- No use químicas fuertes ni limpiadores abrasivos en este artículo
- Nunca empuje, tire ni arrastre los muebles

Antes de Que Empieces (página 3)

- Lea cuidadosamente cada paso y siga el orden correcto
- Separar y contar todas sus piezas y hardware
- Dése suficiente espacio para el proceso de ensamble
- Tenga las siguientes herramientas: destornillador de cabeza plana, #2 cabeza Phillips
Destornillador y martillo
- Precaución: Si usa un taladro electrónico o un destornillador eléctrico para atornillar, por favor asegúrese que deje de atornillar cuando el tornillo este apretado. Fallar hacer esto puede causar barrer el tornillo.

Sistema de fijar el bloqueo de leva (página 3)

Esta sistema de fijar el bloqueo de leva sera usado en todo el proceso ensamble.

Página 11/14

Necesitará golpear el conector con un martillo para insertarlo completamente. Asegúrese de que el conector esté en la posición que se muestra antes de meterlo en el agujero martillándolo.

Página 12

Acople las patas (G/I) primero y luego la barandilla lateral (F).

Página 15

Acople las patas (H/J) primero y luego la barandilla lateral (F).

Página 20

No ajuste este tornillo completamente.

Página 22

¡IMPORTANTE! EL PANEL POSTERIOR ES UN COMPONENTE ESTRUCTURAL DE ESTA UNIDAD Y DEBE SER INSTALADO ADECUADAMENTE.

Acople el panel posterior como se muestra clavándolo directamente en los bordes sin rematar.

Asegúrese de que la unidad esté derecha.

La distancia de esquina a esquina debe ser la misma.

La esquina inferior del panel posterior estará a nivel con el fondo del estante inferior.

Página 25

Nota: Todos los cajones se arman de la misma forma.

Página 27

Nota: Necesitará golpear los fijadores (11) con un martillo para ajustar de manera segura.

Página 28

Acople las guías primero y luego el tirador.

Nota: Para el cajón superior, deberá utilizar dos pernos (14) para acoplar el tirador (más largo).

Página 29

Para mampostería, hormigón u otros materiales de pared:

Consulte en su ferretería local por anclajes adecuados para acoplar el soporte de seguridad de manera segura.

¡IMPORTANTE: ESTA UNIDAD DEBE ESTAR FIJADA A LA PARED PARA AYUDAR A PREVENIR CAÍDAS. SIGA ESTAS INSTRUCCIONES PARA INSTALAR EL SOPORTE DE SEGURIDAD ANTICAÍDAS INCLUIDO CON ESTE PRODUCTO.

OPCIÓN 1: Fijar a un montante (método aconsejado)

Usando un detector de vigas, encuentre un montante en la pared. Coloque la unidad contra la pared, con el soporte de seguridad alineado en esta ubicación. Para que sea más fácil pasar el tornillo, puede perforar un agujero piloto de 1/8" de diámetro (3 mm) que traspase el soporte de seguridad y el montante. Pase el tornillo por el soporte de seguridad y el montante. Ajuste el tornillo que no quedó completamente ajustado en el paso 11.

OPCIÓN 2: Fijar a un muro seco

Ubique la unidad contra una pared, en el lugar que desee, y marque la pared usando el soporte de seguridad. Luego, corra la unidad a un lado. Perfore un agujero de 3/16" de diámetro (5 mm) en el muro seco. Martille el anclaje para pared en el agujero hasta que quede nivelado. Ponga la unidad en posición y ajuste el soporte de pared al anclaje de pared con el tornillo. Ajuste el tornillo que no quedó completamente ajustado en el paso 11.

Página 30

Nota: Los agujeros del soporte del cajón tienen ranuras. Se puede ajustar el frente de los cajones aflojando los tornillos, realizando los ajustes necesarios y volviendo a ajustar los tornillos.

Página 31

CARGA MAXIMA

Esta unidad ha sido diseñada para soportar la carga máxima anotada. El exceder estos límites puede causar inestabilidad, colapsarse y/o causar serias lesiones.

ADVERTENCIA: Riesgo de lesiones a las personas - no coloque un televisor sobre muebles. Este mueble no está aprobado para su uso con un televisor.

Página 32

Registre su producto para recibir lo siguiente:

- * Detalles de nuevas tendencias - Vistazo a lo nuevo
- * Encuestas - alec su voz entre su comunidad
- * Códigos de ofertas y descuentos exclusivos
- * Fácil y rápido servicio de partes de remplace

Para registrar su producto, visite ameriwoodhome.com

Clasificación de 5 estrellas

Visite el sitio web de su tienda local, califique su comprado y denos sus comentarios!

Nos gustaría enviar un gran "Agradecimiento" a todos nuestros clientes por tomarse el tiempo de ensamblar este producto de Ameriwood Home, y por darnos sus valiosos comentarios.

Gracias

Couverture Avant

CE LIVRET D'INSTRUCTION CONTIENT DES INFORMATIONS **IMPORTANTES** SUR LA SÉCURITÉ. VEUILLEZ LIRE ET GARDER POUR UNE RÉFÉRENCE FUTURE

Ne retournez pas ce produit! Contactez notre équipe de service à la clientèle amicale d'abord pour obtenir de l'aide.

Appelez-nous: 1-800-489-3351 (sans frais) du Lundi au Vendredi de 9h à 17h Heure Centrale

Visitez: www.ameriwoodhome.com

ATTENTION

Le meuble peut basculer et causer des blessures graves ou la mort.

Ancrer le meuble à une planche murale dans le mur (si indiqué).

Ne laissez pas les enfants grimper sur le meuble.

Placez les articles lourds sur les étagères ou dans les tiroirs inférieurs.

Astuces Utiles (page 2)

-Ouvrez votre article dans la zone que vous prévoyez de le garder pour moins de levage lourd

-Identifier, trier et compter les pièces avant d'essayer d'assembler

-Les goujons de compression sont taraudés avec un Marteau

-Les glissières sont marquées d'un R (droit) et d'un L (gauche) pour un bon placement

-Assurez-vous toujours de faire face la pointe situé sur le haut de la Serrure de Came vers le bord extérieur

-Utiliser tous les clous fournis pour le panneau arrière et les répartir également

-Le panneau arrière doit être utilisé pour vous assurer que votre appareil est robuste

-N'utilisez pas de produits chimiques agressifs ou de nettoyeurs abrasifs sur cet appareil

-Ne jamais pousser, tirer, ou faire glisser votre meuble

Avant de Commencer (page 3)

-Lisez attentivement chaque étape et suivez le bon ordre

-Séparez et comptez toutes vos pièces et matériaux

-Donnez-vous suffisamment de place pour l'assemblage

-Avoir les outils suivants: tournevis à tête plate, #2 tournevis Phillips, et Marteau

-Attention: Si vous utilisez une perceuse électrique ou un tournevis électrique pour visser, veillez à ralentir et arrêter lorsque la vis est bien serrée. Le non-respect de cette consigne peut endommager la vis.

Système de Fixation de Came (page 3)

Ce Système de Fixation de Came sera utilisé tout au long de l'assemblage

Page 11 / 14

Vous devrez taper sur le connecteur avec un marteau pour l'insérer complètement. Assurez-vous que le connecteur est dans la position illustrée avant de taper dans le trou.

Page 12

Fixez d'abord les pieds (G / I), puis le rail latéral (F).

Page 15

Fixez d'abord les pieds (H / J), puis le rail latéral (F).

Page 20

Ne serrez pas complètement cette vis.

Page 22

IMPORTANT! LE PANNEAU ARRIÈRE EST UNE PARTIE STRUCTURELLE DE CETTE UNITÉ ET DOIT ÊTRE INSTALLÉ CORRECTEMENT.

Fixez le panneau arrière comme indiqué en clouant directement dans les bords bruts.

Assurez-vous que l'unité est carrée.

La distance d'un coin à l'autre doit être égale.

Le bord inférieur du panneau arrière sera aligné avec le bas de la tablette inférieure.

Page 25

Remarque: tous les tiroirs s'assemblent de la même manière.

Page 27

Remarque : Vous devrez taper sur les fixations (11) avec un marteau pour les fixer solidement.

Page 28

Fixez d'abord les glissières, puis la poignée.

Remarque : Pour le tiroir supérieur, vous utiliserez deux boulons (14) pour fixer la poignée (plus longue).

Page 29

Pour la maçonnerie, le béton ou d'autres matériaux de mur :

Consultez votre quincaillerie locale pour les ancrages appropriés pour fixer solidement le support de sécurité.

IMPORTANT : CETTE UNITÉ DOIT ÊTRE FIXÉE AU MUR POUR AIDER À ÉVITER LE RENVERSEMENT. SUIVEZ CES INSTRUCTIONS POUR INSTALLER LE SUPPORT DE SÉCURITÉ ANTI-BASCULE FOURNI AVEC CE PRODUIT.

OPTION 1 : Fixation à un montant mural (méthode préférée)

À l'aide d'un localisateur de montants, localisez un montant dans le mur. Placez votre appareil contre le mur, avec le support de sécurité aligné à cet endroit. Pour faciliter l'enfoncement de la vis, vous pouvez percer un trou pilote de 1/8 "de diamètre (3 mm) à travers le support de sécurité dans le goujon. Passez la vis à travers le support de sécurité dans le goujon mural. Serrez la vis qui n'a pas été complètement serrée. étape 11.

OPTION 2 : Fixation dans une cloison sèche

Placez votre appareil à l'endroit souhaité contre un mur et marquez le mur à travers le support de sécurité, puis écarter votre appareil. Percez un trou de 3/16 po de diamètre (5 mm) dans le panneau mural. Insérez l'ancrage mural dans le trou jusqu'à ce qu'il affleure. Placez votre appareil en place et fixez le support mural à l'ancrage mural avec la vis. Serrez la vis qui était pas complètement serré à l'étape 11.

Page 30

Remarque : les trous du support de tiroir sont fendus. Les façades des tiroirs peuvent être ajustées en desserrant les vis, en effectuant les ajustements nécessaires et en resserrant les vis.

Página 31

CHARGES MAXIMALES

Ce meuble a été conçu pour supporter les charges maximales indiquées. En excédant ces limites de charge, le meuble pourrait devenir instable, s'effondrer, et/ou causer des blessures graves.

AVERTISSEMENT : Risque de blessure corporelle - ne pas placer une télévision sur ce meuble. Ce meuble n'est pas approuvé pour une utilisation avec une télévision.

Page 32

Enregistrez votre produit pour recevoir les éléments suivantes:

- * Détails sur les nouvelles tendances - un aperçu sur les nouveautés
- * Sondages - avoir une voix au sein de notre communauté
- * Offres exclusives et codes promo
- * Service de pièces de rechange rapide et facile

Pour enregistrer votre produit, visitez ameriwoodhome.com

5 Étoiles

Visitez le site Web de votre détaillant local, évaluez votre produit acheté et laissez-nous quelques commentaires !

Nous tenons à offrir un grand "Merci" à tous nos clients pour avoir pris le temps d'assembler ce produit "Ameriwood Home", et de nous donner vos commentaires précieux.

Merci