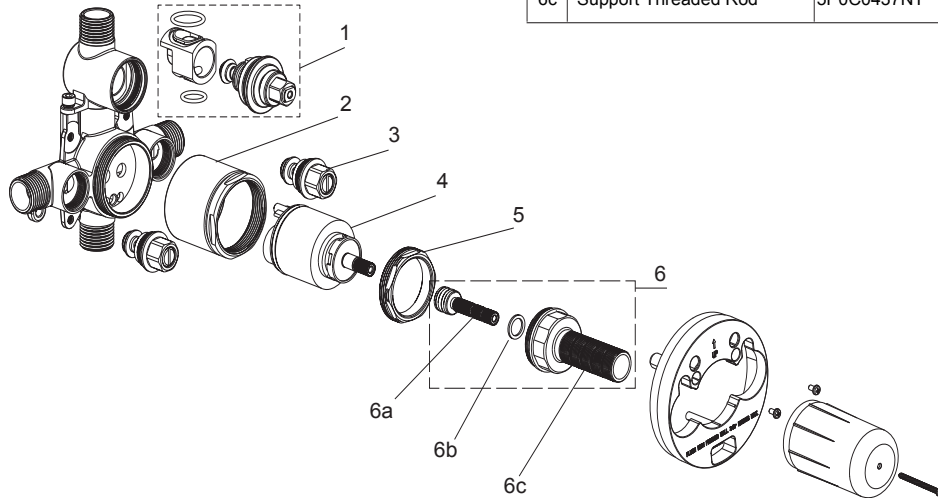

Replacement Parts / Pièces de rechange / Repuestos
UFP-PBV2

NO.	Description	Part No.
1	Diverter Assembly	9Q1153NT
2	Sleeve	5L0C0861NT
3	Stop Valve	9Q1152NT
4	Pressure Balance Cartridge	5D0M0262PL
5	Cartridge Nut	5T1C0216NT
6	Stem & Threaded Nipple	9Q1173NT
6a	Rod	5P0C0438NT
6b	Washer	5R4P0095PL
6c	Support Threaded Rod	5P0C0437NT

Limited Lifetime Warranty

Ultra Faucets warrants to the original purchaser that its products will be free from defects in workmanship and materials. All Ultra Faucets are provided with a life time limited warranty. This warranty does not cover any other labor or service charges associated with the removal, repair, or reinstallation of Ultra Faucets products. This express warranty does not apply to products that have been damaged as a result of misuse, abuse, negligence, accident, faulty installation or maintenance practices and/or used in any manner contrary to those recommended by the manufacturer.

Need help? Please call our toll-free customer service line at 1-888-658-5872 for additional assistance or service.

Besoin d'aide? Veuillez communiquer avec notre service à la clientèle au numéro gratuit 1-888-658-5872 pour tous renseignements ou services complémentaires.

¿Requiere asistencia? Llame a nuestro Servicio al Cliente, sin costo, al 1-888-658-5872 para asistencia adicional o servicio.

Installation/Installation/Instalación

CUSTOMER SERVICE
TOLL-FREE 1-888-OK-ULTRA (658-5872)

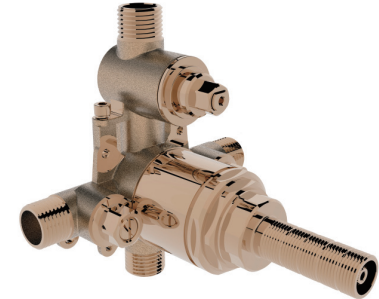
Tools You Will Need / Outils dont vous aurez besoin / Herramientas necesarias

Adjustable Wrench
Clé à molette
Llave ajustable



Pipe Tape
Ruban pour tuyau
Cinta selladora para rosca



Groove join pliers
Pince multiprise
Pinzas ajustables

SAFETY TIPS

- If you use soldering for the installation of the faucet, the seats, cartridges and washers will have to be removed before using flame. Otherwise, warranty will be void on those parts.
- Cover your drain to avoid losing parts.
- 0°C~55°C.

CONSIGNES DE SÉCURITÉ

- Si vous posez le robinet par brasage, il est essentiel de retirer les sièges, les cartouches et les rondelles avant d'appliquer la flamme, faute de quoi la garantie sur ces pièces sera annulée.
- Couvrez le drain pour ne pas perdre des pièces.
- 0°C~55°C.

CONSEJOS DE SEGURIDAD

- En el caso de utilizar soldadura para instalar el grifo, remueva los asientos, cartuchos y arandelas antes de usar la llama. De lo contrario, se anulará la garantía para esos componentes.
- Tape la boca del desagüe para prevenir la pérdida de piezas pequeñas.
- 0°C~55°C.

Installation/Instalación

UFP-PBV2

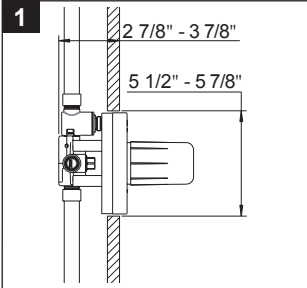

Turn off the water supplies. Install the valve so the finished wall will fit between the markers on the mud guard.

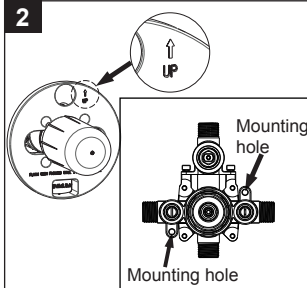

Using mounting holes secure the valve making sure the "UP" label outlet is on top.

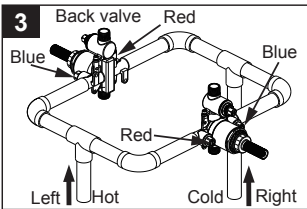

If you are making a back-to-back installation (hot on right and cold on the left), install the back valve body as described in steps #5 – #6. If not, go to step #7. NOTE: Notice that the back valve has hot and cold indicators that will be opposite of the incoming supply lines.

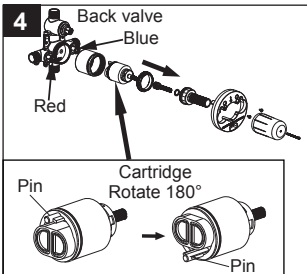

Remove the cartridge and stem assembly. Notice that the pin is at the top. Rotate the cartridge 180°. The pin should be on the bottom.

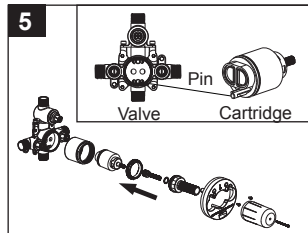

Align the pins on the bottom of the cartridge and push the cartridge into the valve. Make sure the cartridge is firmly installed into the valve body. Reinstall stem assembly with mud guard.

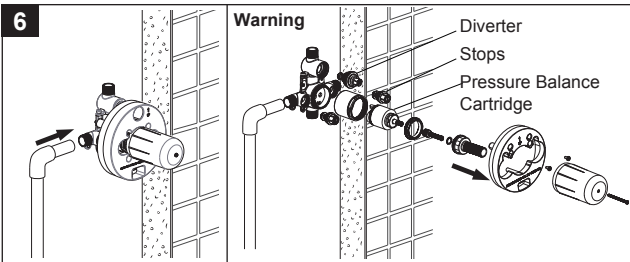

Connect valve body to water supplies using the proper fittings (copper tubing or pex). Warning: avoid soldering at high temperature. Exposure to high temperature may damage the cartridge. Be sure diverter, stops and pressure balance cartridge are removed before soldering. Note: Flip the cartridge for back-to-back installation.

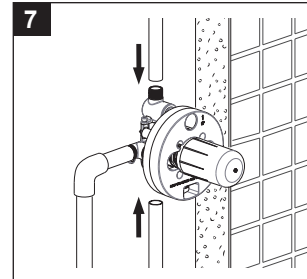

Connect the valve body to the outlets with the proper fitting. Note: it is suggested that you anchor all water lines.

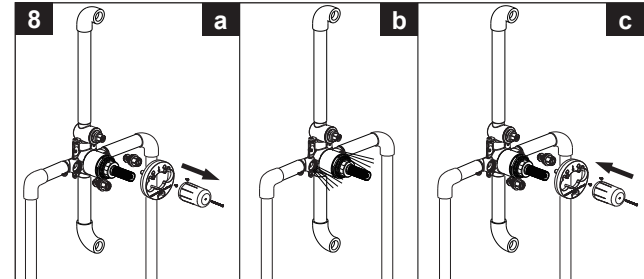

Flush the supply lines.
a. Remove mud guard and stops.
b. Turn the water on for 30 seconds and check for leaks.
c. Turn the water off. Re-install the stops and mud guard.

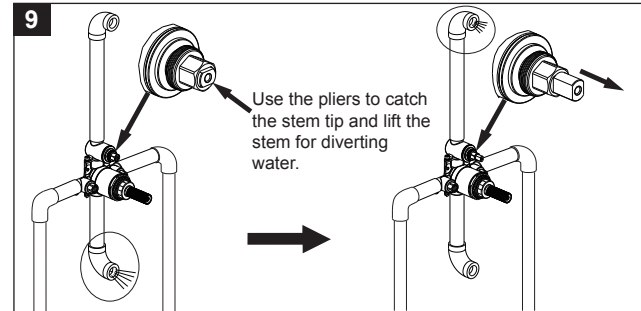

Use the pliers or the diverter knob from the trim kit (not included) to lift the stem for diverting water.

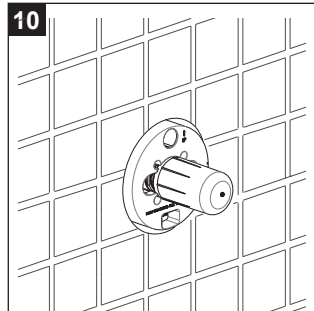

Installation completed.