

LED STEP LIGHT

INSTRUCTIONS



DESCRIPTION

LED step lights bring soft, low level illumination to any environment. Fitting into a standard junction box (single-gang, handy box, 2" minimum inside width) for easy installation, both operate on 120v, delivering up to 160 lumens & 70 lumens (accordingly) of illumination.

TOOLS AND MATERIALS REQUIRED:



Phillips
Screwdriver



Wire Cutters



Pliers



Wrench

Wiring supplies
as required
by your local
Provincial or
State Electrical
Code

FIGURE 1

Installation diagram

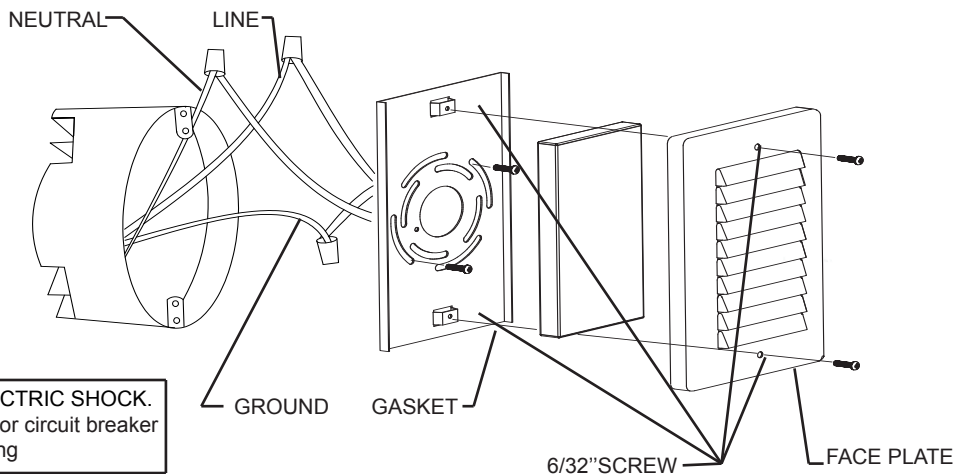

WARNING: RISK OF ELECTRIC SHOCK.
Disconnect power at fuse or circuit breaker
before installing or servicing

INSTRUCTIONS

1. REMOVE THE UNIT FROM THE PACKAGE
2. INSPECT FOR ANY SHIPPING DAMAGE
3. REFER TO FIGURE 1
4. CONNECT POWER SUPPLY LEADS PER NEC REQUIREMENTS
5. PLACE HOUSING IN JUNCTION BOX & SECURE WITH 2 X 6/32" SCREWS
6. SECURE WALL PLATE TO BRACKET WITH 2 X 6/32" SCREWS

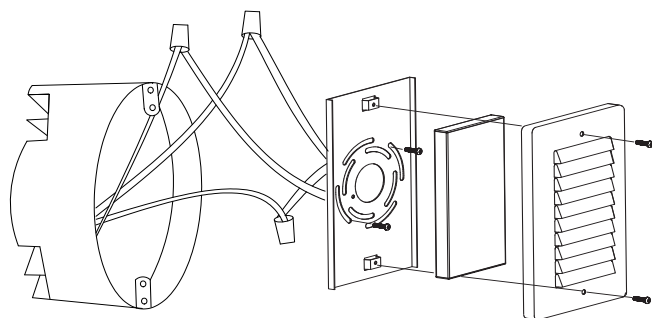

NOTICE: These instructions do not claim to cover all details or variations in the equipment, procedure, or process described, nor to provide directions for meeting every possible contingency during installation, operation or maintenance. When additional information is desired to satisfy a problem not covered sufficiently for user's purpose, please contact your nearest representative. Design, specifications and dimension are subject to change without notice.