

VANITY LIGHT

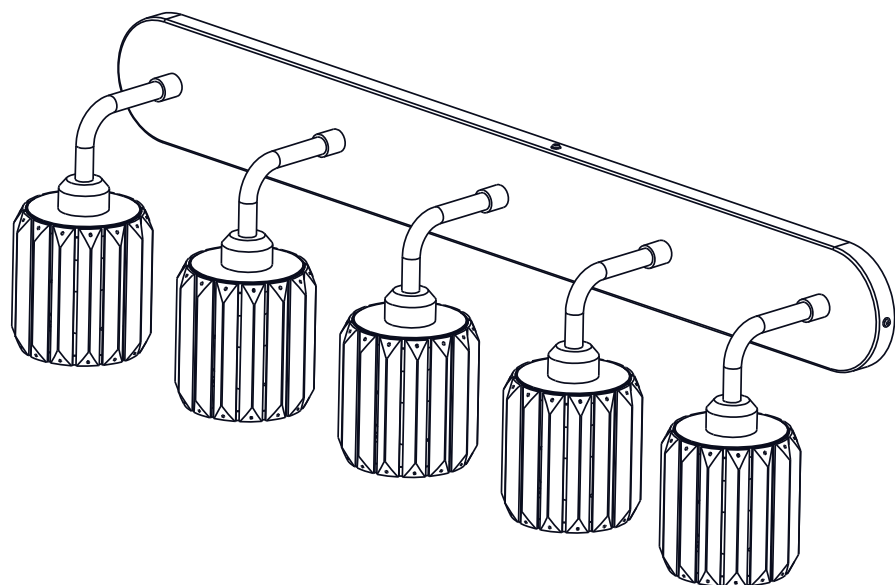

Installation Instruction

If you have any problem, please feel free to contact us on

Help@ZRSupport.com

INSTALLATION MANUAL

VANITY LIGHT

CONTACT US

Thank you for shopping with us! We hope that our products have added a touch of brightness to your life. If you need any assistance, please don't hesitate to reach out. Our dedicated team is available 24/7 to ensure your satisfaction.

✉ Help@ZRSupport.com ☎ 1-888-204-3326 📘 ZRSupport

WARNING

To avoid the risk of electrical shock, **turn off the power** at the circuit breaker or fuse box before installing or servicing this fixture.

Before installation, consult **local electrical codes** to ensure compliance with wiring and grounding requirements.

Important: Read and save these instructions for future reference.

TOOLS REQUIRED



Phillips Screwdriver

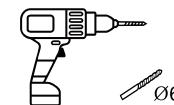

Electric Drill



Ladder

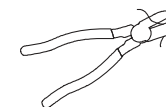

Wire Cutters



Spanner



Electrical Tape



Hammer



Safety Goggles

BEFORE INSTALLATION

Before You Begin

1. **Check for Completeness:** Ensure all parts are present by comparing them with the **package contents list** and **hardware contents list**.
2. **Inspect for Damage:** If any part is missing or damaged, **do not attempt to assemble the product**.

Important Notes

- Keep the packaging until assembly is complete to prevent losing any parts.
- **Light bulbs are not included** with this product and must be purchased separately.

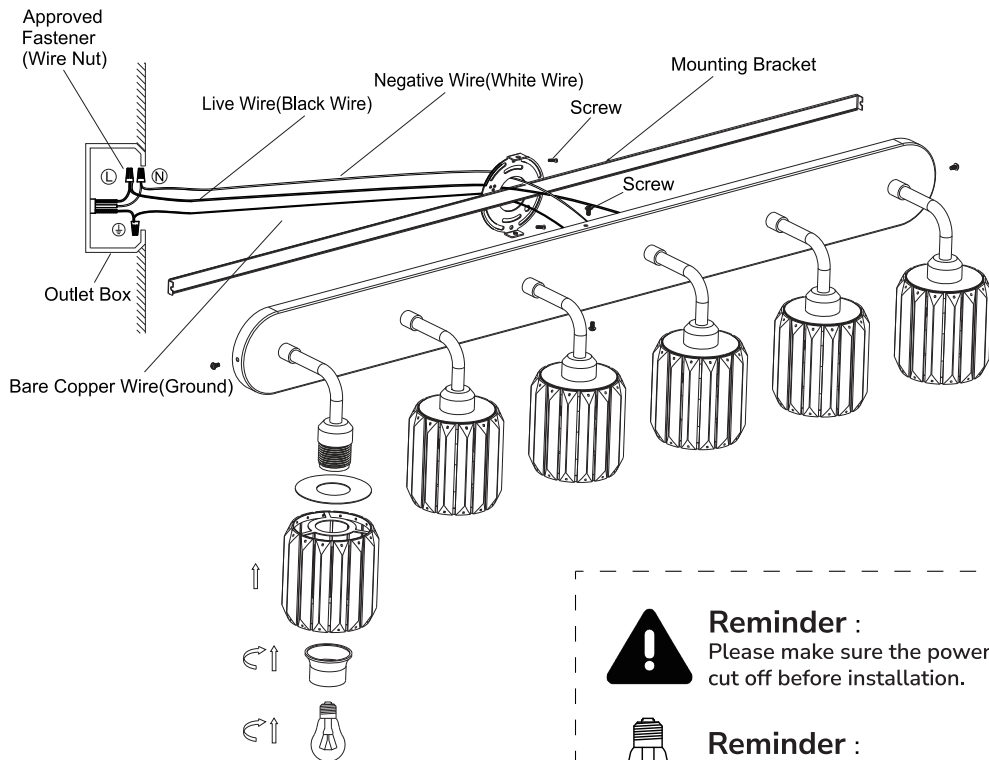



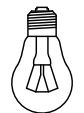









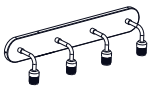

Reminder :
Please make sure the power is cut off before installation.

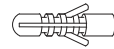

Reminder :
Bulb base: E26
LED light maximum: 4~8W

PACKING LIST

							
Item	Illustration	1-light	2-light	3-light	4-light	5-light	6-light
A		x1	x1	x1	x1	x1	x1
B		x1	x2	x3	x4	x5	x6
C		x1	x2	x3	x4	x5	x6
D		x1	x1	x1	x1	x1	x1
E		x2	x2	x2	x2	x2	x2
F		x3	x3	x3	x3	x3	x3
G		0	x2	x2	x2	x2	x2
H		0	x2	x2	x2	x2	x2
I		x1	x1	x1	x1	x1	x1

1. Remove the screws from the top, bottom, and both sides of the light, then remove the mounting bracket.

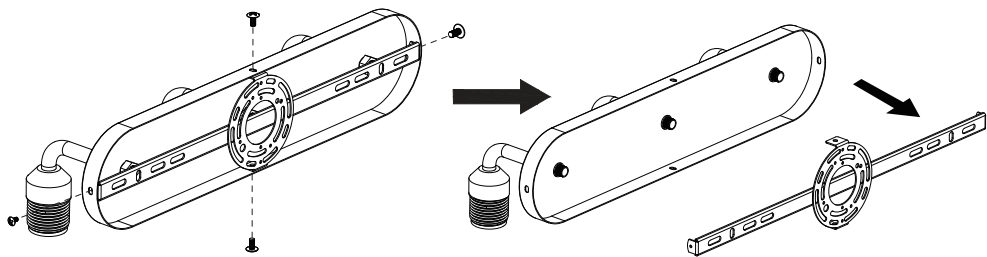

2. Thread the ground wire, gasket, and nut onto the wire in that order. Push them firmly against the light base and tighten the nut securely with a wrench.

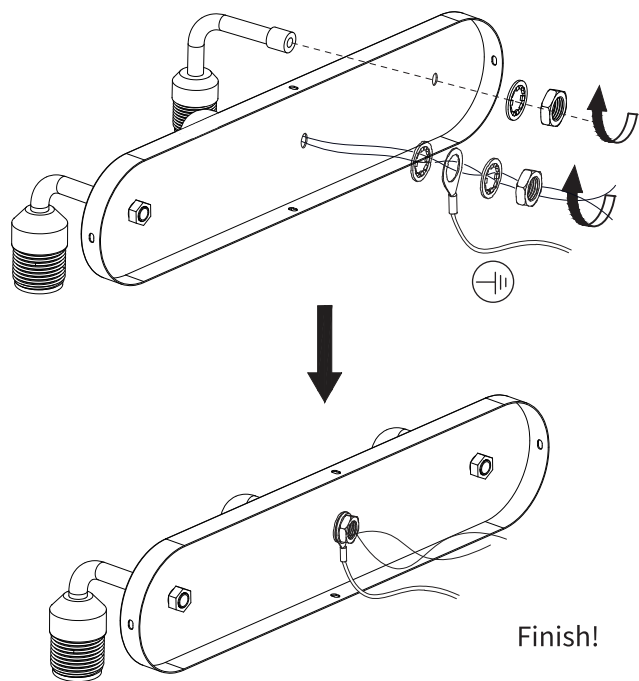

4

3. Install the mounting bracket.

3.1 For 1-light to 3-light versions:

Place mounting bracket on the junction box and secure it with screws **E**.

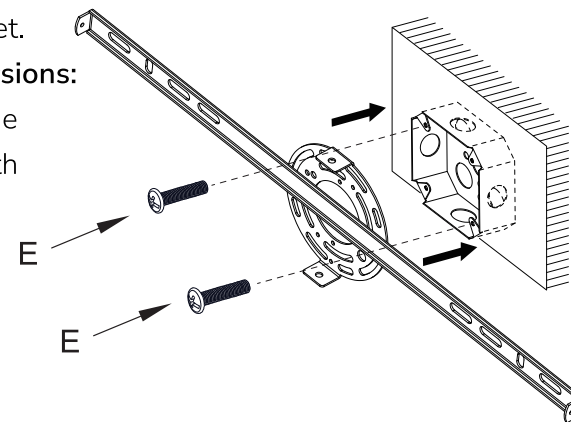

3.2 For 4-light and 6-light versions: Place mounting bracket on junction box and adjust it horizontally. Mark the holes on both sides ①. remove the bracket, drill holes with an electric drill, and insert rubber plugs **H** ②. Reposition the mounting bracket, fix it to the junction box with screw **E**, and then secure with screw **G** ③.

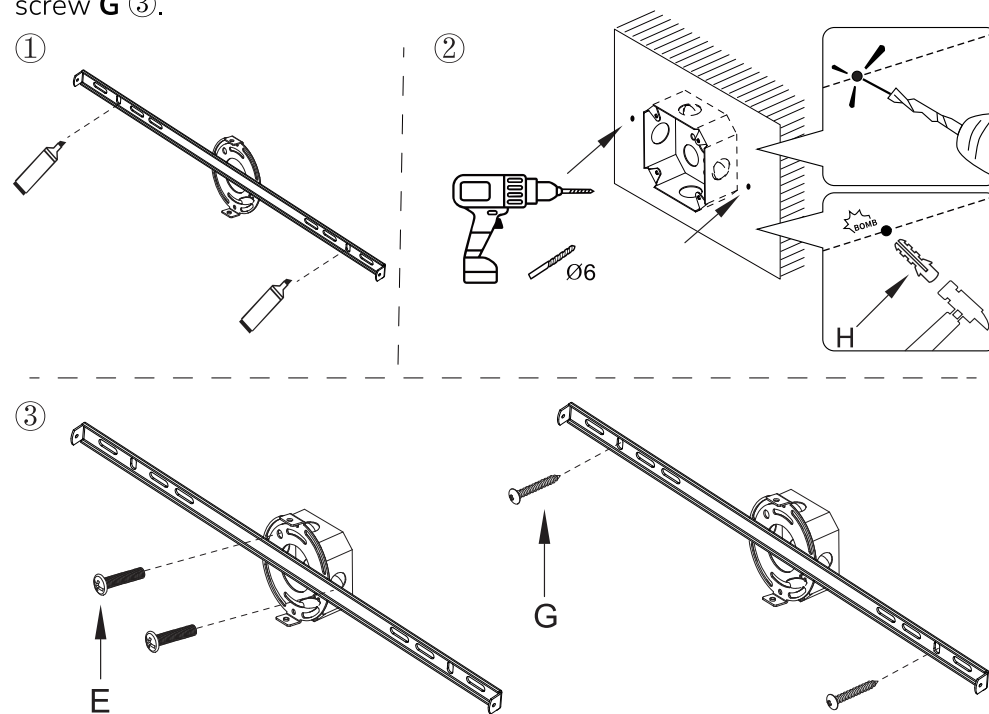

5

4. Identify the live wire, neutral wire, and ground wire by their colors. Match and connect the light base wires to the corresponding wires in the junction box based on color. Secure the connections by twisting the wires together and screwing them into terminal cap **F**.



Reminder :

Please make sure the power is cut off before installation.

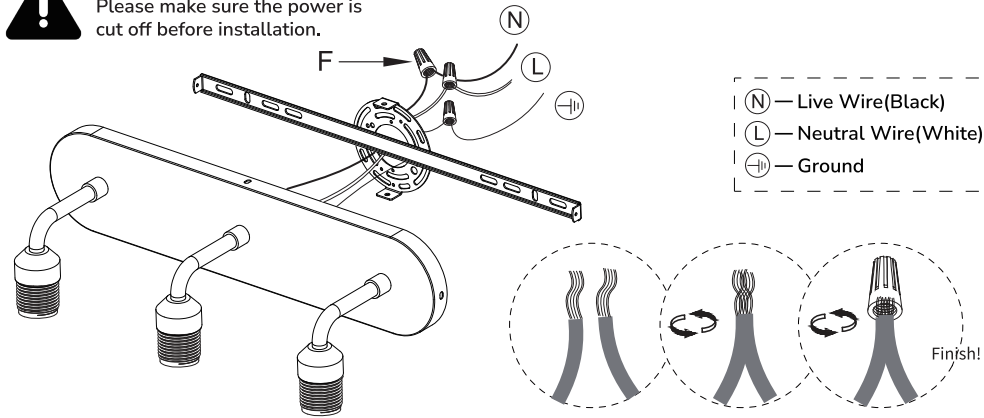

6. The ring **B** is attached to light body. Unscrew ring **B** ①, install the lampshade onto the light body and secure it in place by threading Ring **B** back on ②.

①

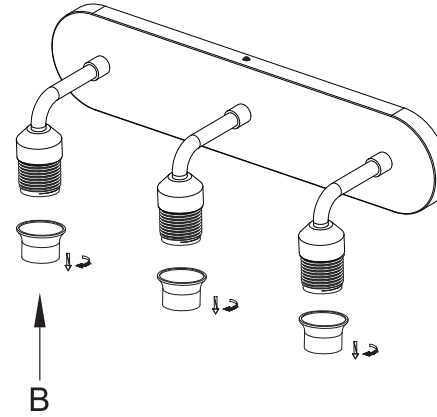

②

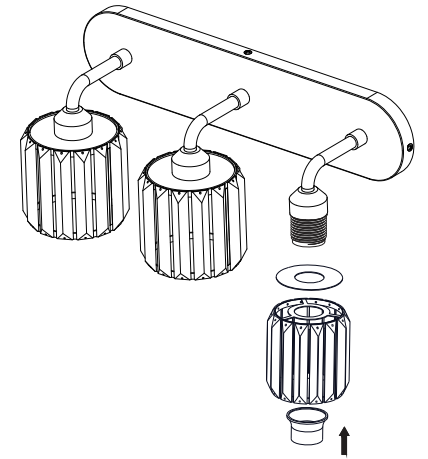

5. Align the light body with the mounting bracket ①, then secure it by installing screws at the top, bottom, and on both sides ②.

①

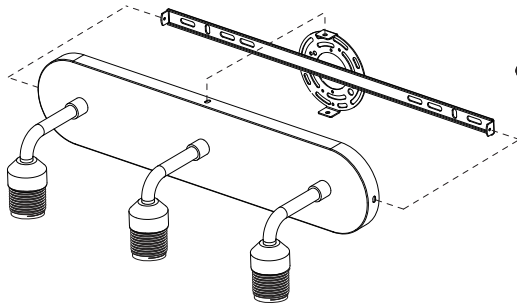

②

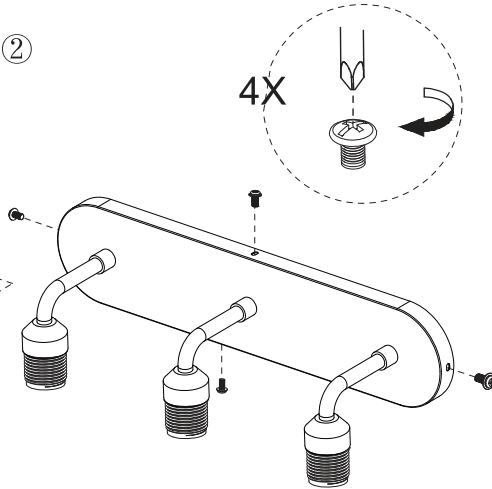

6

7. Screw the purchased light bulb into the light body. Adjust the light body as needed ①, then turn on the power and confirm that the light is working ②.

①

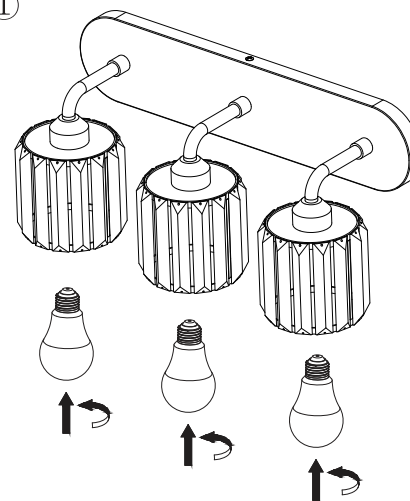

②

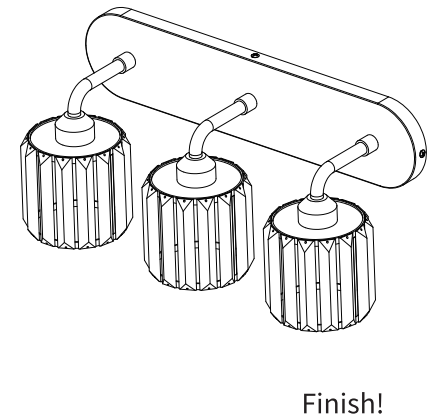

7