

***Assembly Instructions***  
***Instrucciones De Ensamblaje***  
***Instructions D'Assemblage***



**LIMITED 90 DAYS WARRANTY****GARANTÍA LIMITADA DE 90 DÍAS****GARANTIE LIMITEE DE 90 JOURS**

This product is covered by a limited warranty that is effective for 90 days from the date of purchase. If, during the limited warranty period, a part is found to be defective or breaks, we will offer replacement parts at no cost to you, the customer. The only exceptions to the warranty include mainframes, table tops, playing surfaces, batteries or tools.

The above warranty will not apply in cases of damages due to improper usage, alteration, misuse, abuse, accidental damage or neglect.

This Limited Warranty gives you specific legal rights and you may also have other rights vary from one State (province) to another.

A PURCHASE RECEIPT (or other proof of purchase) will be required before any warranty service is initiated. For all requests for warranty service, please feel free to contact our Consumer Service Department.

Please be aware of your product's Limited Warranty for the return/refund policy from the store. We, at Medal Sports, cannot handle the product which is out of product's limited warranty since we only provide available parts. Thank you!

**PLEASE CONTACT US BEFORE RETURNING THE PRODUCT TO THE STORE!**

Este producto está cubierto por una garantía limitada que tiene una vigencia de 90 días a partir de la fecha de su compra. Durante el período de la garantía limitada, si una parte defectuosa o quebrada es encontrada, nosotros ofreceremos una reparación o un reemplazo de la partes sin ningún costo para usted, nuestro cliente. Las únicas excepciones de la garantía incluyen unidades centrales, tableros de mesa, superficies de juego, pilas o herramientas.

La susodicha garantía no se aplicará en los casos de daños debido al uso impropio, la alteración, el mal uso, el abuso, el daño accidental o la negligencia.

Esta garantía limitada le da a usted derechos legales específicos, usted también puede tener otros derechos que varían de un estado (provincia) a otro.

EL RECIBO DE LA COMPRA (U otra prueba de compra) sería requerida antes que cualquier servicio de garantía fuera iniciada. Para todo pedido por servicio de garantía, por favor siéntase libre de ponerse en contacto con nuestro Departamento de Servicio de Consumidor.

Por favor tenga en cuenta sobre la Garantía Limitada de su producto para la política de vuelta/reembolso desde la tienda. Nosotros, Medal Sports, no podemos manejar el producto que está fuera del límite de garantía ya que proporcionamos solamente partes disponibles. ¡Gracias!

**¡POR FAVOR PÓNGASE EN CONTACTO CON NOSOTROS ANTES DE DEVOLVER EL PRODUCTO A LA TIENDA!**

Ce produit est couvert par une garantie limitée valable 90 jours à compter de la date d'achat. Si pendant cette période une pièce est jugée défectueuse ou se casse, nous la remplacerons gratuitement. Les seules exceptions à la garantie comprennent les armatures principales, les dessus de table, les surfaces de jeu, les piles ou les outils.

La garantie ci-dessus ne s'applique pas en cas de dommages occasionnés par une mauvaise utilisation, une altération, un abus, des un dommage accidentel ou une négligence.

Cette garantie limitée vous accorde des droits légaux spécifiques ainsi que d'autres droits variant d'un état (province) à un autre.

UNE FACTURE D'ACHAT (ou toute autre preuve d'achat) sera exigée avant toute intervention sous garantie. Pour toute demande d'intervention sous garantie, veuillez contacter notre Service Clientèle.

Comprenez votre garantie limitée de produit en ce qui concerne notre politique de retour/remboursement depuis le magasin. Chez Medal Sports, nous ne pouvons pas traiter un produit qui n'est plus sous garantie puisque nous ne pouvons que fournir les pièces disponibles. Remerciements!

**VEUILLEZ NOUS CONTACTER AVANT DE RETOURNER LE PRODUIT AU MAGASIN!**



**WE ARE READY TO HELP**

**DO NOT RETURN TO STORE**

**ESTAMOS LISTOS AYUDA**

**NO DEVOLVERLO A LA TIENDA**

**NOUS SOMMES PRÊTS À VOUS AIDER**

**NE PAS RAPPORTE EN MAGASIN**

**Please Contact | Por favor Contactar | Veuillez contacter**

**MD SPORTS**

Customer Service  
Toll Free

Servicio al Cliente  
Llamada Gratuita

Service Clientèle  
Appel Gratuit

**877-472-4296**

Mon.-Fri.,  
9:00 a.m. to 5:00 p.m. EST

Lunes a Viernes,  
9:00 a.m. a 5:00 p.m. ET

Du lundi au vendredi de  
9:00 a 17 heures HNE

For additional resources and  
Frequently Asked Questions,  
please visit us at

Por mayor información y  
Preguntas Frecuentes, favor  
visitarnos en

Pour toute information  
complémentaire ou réponse  
aux questions fréquentes,  
veuillez vous rendre sur

**www.medalsports.com**

## TOOLS REQUIRED

Phillips Screwdriver - **Not Included**  
 Standard (Flat Head) Screwdriver - **Not Included**  
 Allen Key - **Included**  
 Wrench - **Included**



## RECOMMENDED

Electric Screwdrivers may be helpful during assembly; however, please set a low torque and use extreme caution.



Power Tools: **Set to Low Torque**  
 / Herramientas eléctricas: **Establecer a baja velocidad**  
 / Visseuse électrique : **Couple faible**



High Torque Over Tightened  
 / Una alta velocidad puede apretar demasiado  
 / Un couple élevé peut créer des dommages

## HERRAMIENTAS NECESARIAS

Destornillador Phillips - **No incluido**  
 Destornillador de Cabeza Plana - **No incluido**  
 Llave Allen - **Incluido**  
 Llave Inglesa - **Incluido**



## RECOMENDADO

Los destornilladores eléctricos pueden ser de gran ayuda durante el ensamblado; sin embargo, por favor ajuste el par de giro bajo y sea extremadamente precavido.

## OUTILS REQUIS

Tournevis cruciforme - **Non inclus**  
 Tournevis standard (Tête plate) - **Non inclus**  
 Clé hexagonale - **Incluse**  
 Clé anglaise - **Incluse**



## RECOMMANDÉ

Un tournevis électrique peut être utile pour l'assemblage; utilisez cependant une vitesse de rotation lente et avec prudence.

## ! IMPORTANT NOTICE

1. This product is intended for INDOOR use only.
2. Please do not sit, climb or lean on the product.
3. Please do not drag the product when moving it in order to avoid damaging the legs.
4. Please only use furniture polish spray to clean the exterior surfaces of the product.
5. This is not a children's toy.
6. Adult assembly required.

## AVISO IMPORTANTE

1. Este producto está destinado para el uso INTERIOR solamente.
2. Por favor no se siente, suba o incline sobre el producto.
3. Por favor no arrastre el producto cuando lo mueva de lugar para evitar daño en las patas de la mesa.
4. Por favor use solamente spray de pulido para muebles para limpiar la superficie exterior del producto.
5. Este no es un juguete para niños.
6. El ensamblaje debe ser realizado por un adulto.

## NOTE IMPORTANTE !

1. Ce produit est conçu pour une utilisation en intérieur uniquement.
2. Veuillez ne pas vous asseoir, grimper ou vous appuyer sur la produit.
3. Veuillez ne pas déplacer la produit en la tirant pour ne pas endommager les pieds.
4. Veuillez utiliser seulement le vernis pour meuble pour nettoyer les surfaces extérieures du produit de jeu.
5. Ce n'est pas un jeu d'enfant.
6. L'assemblage doit être effectué par des adultes.



At least 2 adults needed  
 Se necesitan al menos 2 adultos  
 Il faut au moins 2 adultes



No children in assembly area  
 No deben estar los niños en el area de ensamble  
 Pas d'enfants dans la zone d'assemblage



Keep away from pets in assembly area  
 Mantener alejados a los animales domesticos del area de ensamble  
 Tenir les animaux de compagnie à distance



Do not use or keep product outdoors. For indoor use only. No wet/humid conditions.

No usar o guardar el producto en el exterior. Solo para uso en interior. No utilizar ni guardar el producto en lugares húmedos o mojados.

N'utilisez ni ne stockez ce produit en extérieur. Uniquement pour utilisation en intérieur. Ne pas exposer à l'humidité.

**PARTS IDENTIFIER**

**IDENTIFICADOR DE PIEZAS**

**IDENTIFICATEUR DE PIÈCES**

PART NUMBER  
NÚMERO DE PIEZA  
NUMÉRO D'ARTICLE

PART  
PIEZA  
PIÈCE

PART NAME







<b>1</b>	FOR FIG. 2	
		
<b>x1</b>		
Mainframe	Unidad principal	Unité centrale

FIG NUMBER  
NÚMERO DE FIG.  
NUMÉRO FIG.

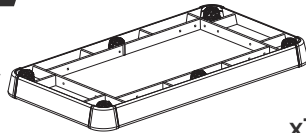
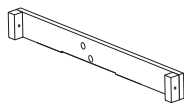
QUANTITY  
CANTIDAD  
QUANTITÉ

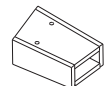
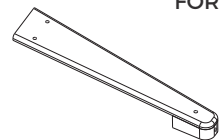
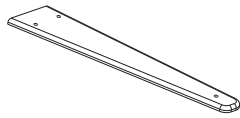

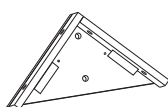
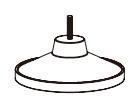
NOM DE LA PIÈCE  
NOMBRE DE PIEZA

<b>2</b>	FOR FIG. 1	<b>3</b>	FOR FIG. 1	<b>4</b>	FOR FIG. 3	<b>5</b>	FOR FIG. 3				
											
<b>x1</b>		<b>x1</b>		<b>x4</b>		<b>x4</b>					
Support Brace	Abrazadera de soporte	Barre de support	Adjustable Bracket	Corchete regulable	Support réglable	Leg-A	Pata-A	Pied-A	Leg-B	Pata-B	Pied-B
<b>6</b>	FOR FIG. 4	<b>7</b>	FOR FIG. 3, 4, 5	<b>8</b>	FOR FIG. 5	<b>9</b>	FOR FIG. 7				
											
<b>x4</b>			<b>x1</b>		<b>x4</b>		<b>x4</b>				
Leg-C	Pata-C	Pied-C	Glue	Pegamento	Colle	Leg Base	Bases de pata	Base pied	Leg Leveler	Nivelador de pata	Niveleur de pied
<b>10</b>	FOR FIG. 7										
											
<b>x8</b>											
Dowel	Clavija	Cheville									

**ACCESSORIES**

**ACCESORIOS**

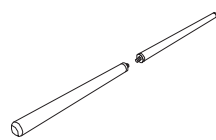
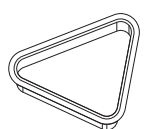
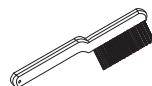

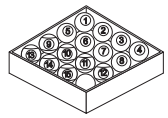



**ACCESSOIRES**

<b>11</b>				<b>12</b>				<b>13</b>				<b>14</b>			
<b>x2</b>			<b>x1</b>			<b>x1</b>			<b>x2</b>						
Cue	Taco	Queue de billard	Triangle	Triángulo	Triangle	Brush	Cepillo	Brosse	Chalk	Tiza	Craie				
<b>15</b>															
<b>x1</b>															
Billiard Ball Set	Bola de billar	Ensemble boules de billard													

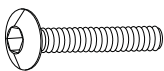
## HARDWARE

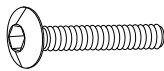
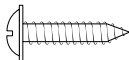
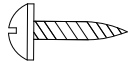
## HARDWARE

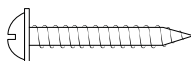
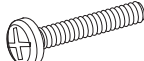
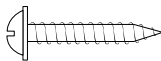





## MÉTAUX

<b>A1</b> FOR FIG. 5, 6  x24			<b>A2</b> FOR FIG. 5, 6  x24			<b>A3</b> FOR FIG. 3, 4  x16			<b>A4</b> FOR FIG. 4  x4		
M8x38mm Bolt	Perno M8x38mm	Boulon M8x38mm	M8 Washer	Arandela M8	Rondelle M8	M6x32mm Bolt	Perno M6x32mm	Boulon M6x32mm	3.5x25mm Screw	Tornillo 3.5x25mm	Vis 3.5x25mm
<b>A5</b> FOR FIG. 2  x2			<b>A6</b> FOR FIG. 3, 4  x16			<b>A7</b> FOR FIG. 5  x8			<b>A8</b> FOR FIG. 1  x2		
4x15mm Screw	Tornillo 4x15mm	Vis 4x15mm	M6 Washer	Arandela M6	Rondelle M6	4x45mm Screw	Tornillo 4x45mm	Vis 4x45mm	M5x25mm Bolt	Perno M5x25mm	Boulon M5x25mm
<b>A9</b> FOR FIG. 2  x2			<b>A10</b>  x1			<b>A11</b>  x1					
4x32mm Screw	Tornillo 4x32mm	Vis 4x32mm	Allen Key	Llave allen	Clé hexagonale	Wrench	Llave inglesa	Clé anglaise			

## PRE-INSTALLED PARTS

## PIEZAS PREINSTALADAS

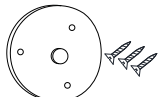
## PIÈCES PRÉINSTALLÉES

<b>P1</b> FOR FIG. 8  x4			<b>P2</b> FOR FIG. 8  x2			<b>P3</b> FOR FIG. 5  x16			<b>P4</b> FOR FIG. 2  x6		
Apron Corner	Cubierta de esquina	Tablier de coin	Side Pocket Cap	Gorra de bolsillo lateral	Capuchon poche latérale	M8 T - Nut	Tuerca - T M8	Écrou en T M8	Pocket	Bolsillo	Poche
<b>P5</b> FOR FIG. 1  x2			<b>P6</b> FOR FIG. 6  x4			<b>P7</b> FOR FIG. 8  x4					
M5 T - Nut	Tuerca - T M5	Écrou en T M5	Round Nut With Screws	Tuerca redonda con tornillos	Écrou rond avec vis	Corner Pocket Cap	Gorra de bolsillo de esquina	Capuchon Poche de coin			

## BEFORE ASSEMBLY

## ANTES DE MONTAR

## AVANT L'ASSEMBLAGE

1. Find a clean, level place to begin the assembly of your product.
2. Verify that you have all listed parts as shown on the part list pages. If any parts are missing, call our customer service.

1. Encuentre un lugar limpio y nivelado para comenzar el ensamblaje del producto.
2. Compruebe que tenga todas las piezas que se muestran en la lista de piezas. Si falta alguna pieza, llame a nuestro servicio al cliente.

1. Trouvez un endroit propre et plat pour commencer à assembler votre produit.
2. Vérifiez que vous avez toutes les pièces énumérées comme indiqué sur les pages de liste des pièces. S'il y a des pièces qui manquent, appelez notre service à la clientèle.

## ASSEMBLY

## MONTAJE

## ASSEMBLAGE

FIG. 1

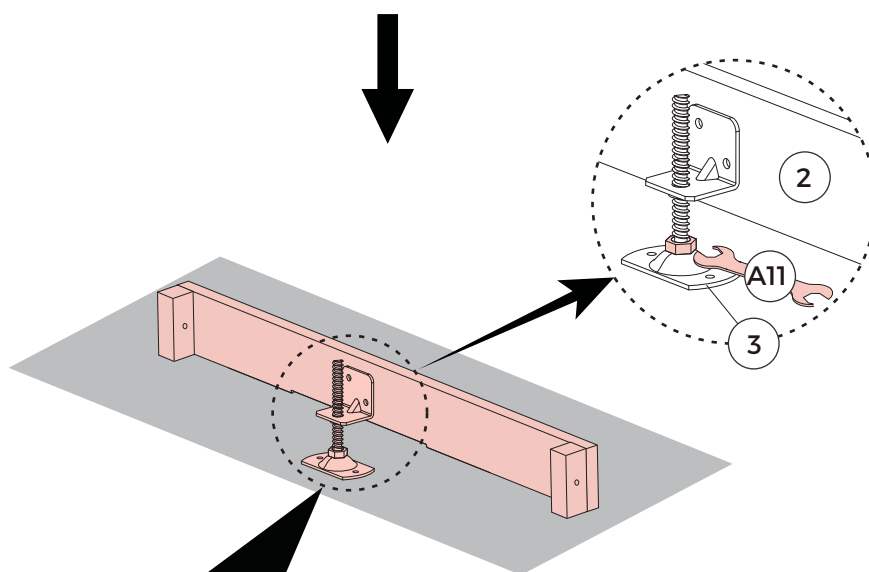
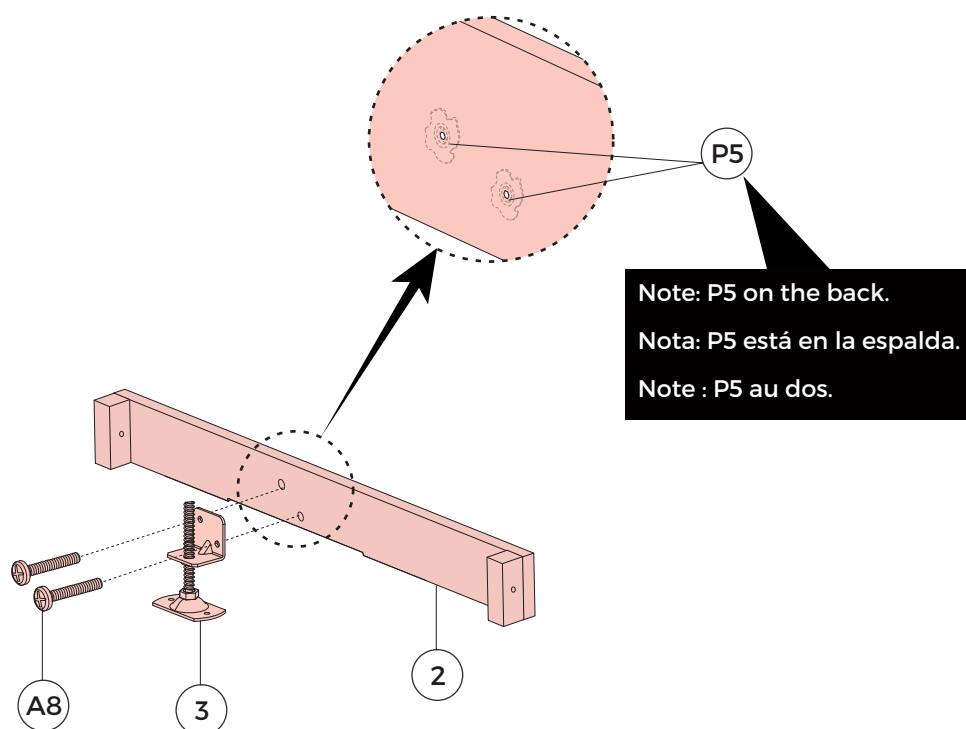
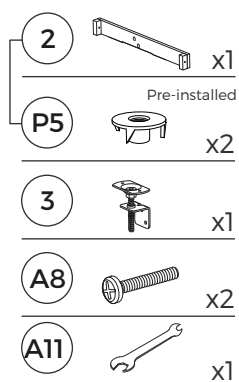

Note: Please note that adjustable bracket (3) and support boards (2) must be parallel with each other.

Nota: Favor notar que los corchete regulable (3) y las placas de soporte (2) deben venire en paralelo.





Note : Veuillez noter que les support réglable (3) et les plateaux de support (2) doivent être parallèles.

## ASSEMBLY

## MONTAJE

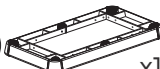
## ASSEMBLAGE

FIG. 2

- 1**  x1
- P4**  Pre-installed x6
- A5**  x2
- A9**  x2

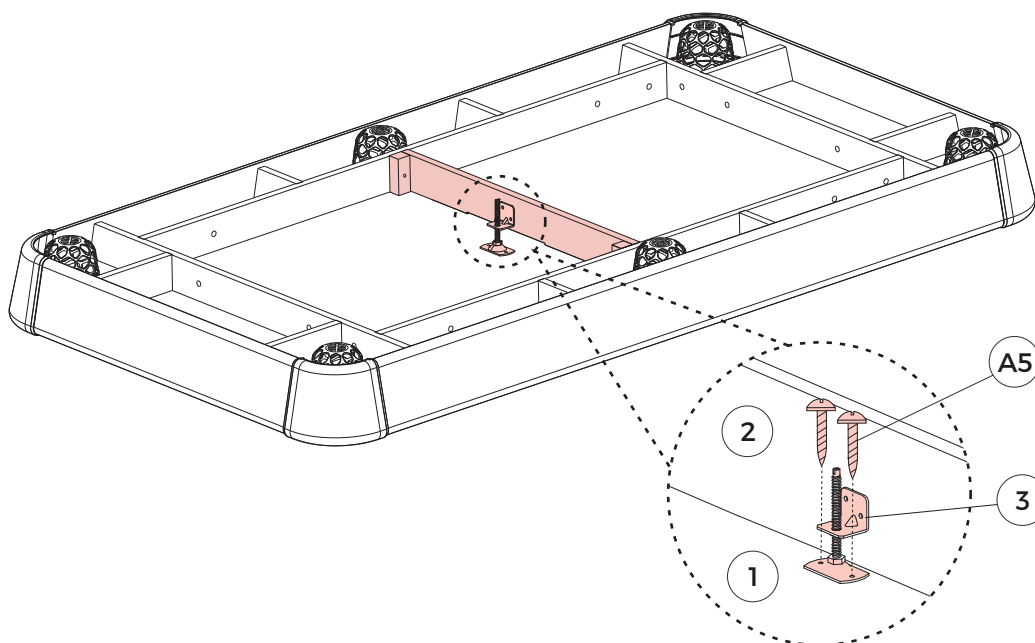
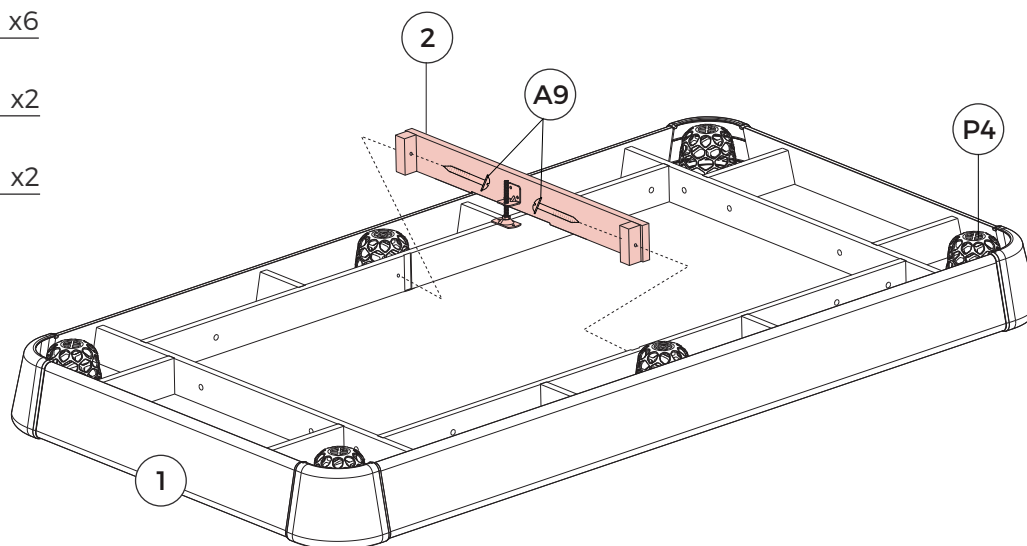

## ASSEMBLY

## MONTAJE

## ASSEMBLAGE

FIG. 3

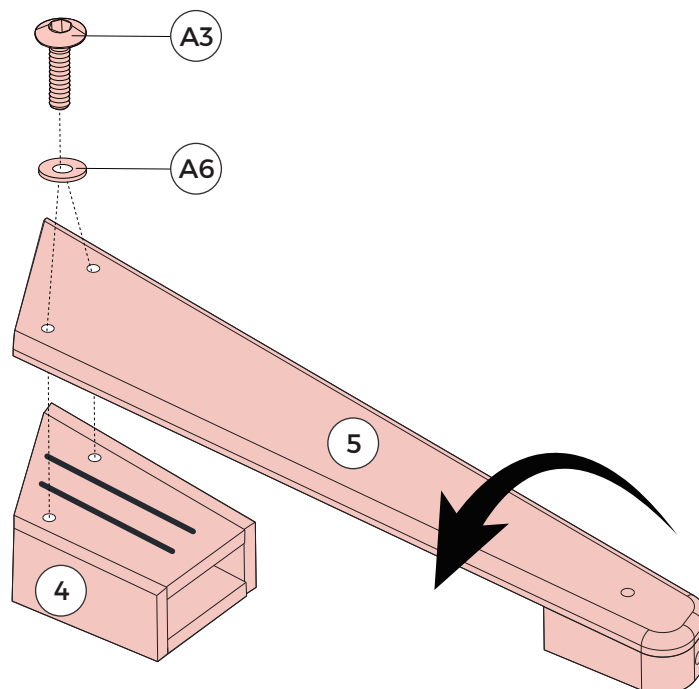
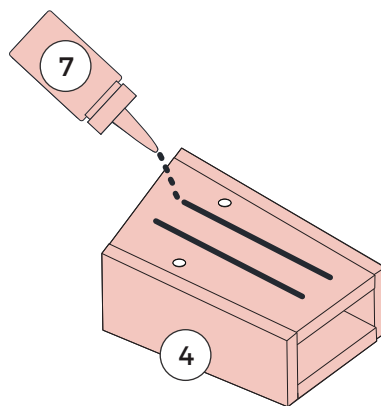
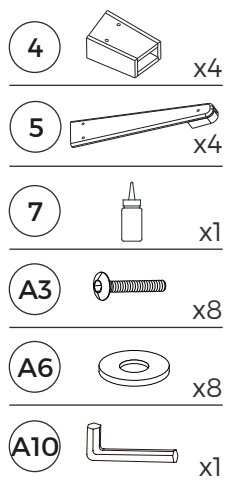

## ASSEMBLY

## MONTAJE

## ASSEMBLAGE

FIG. 4

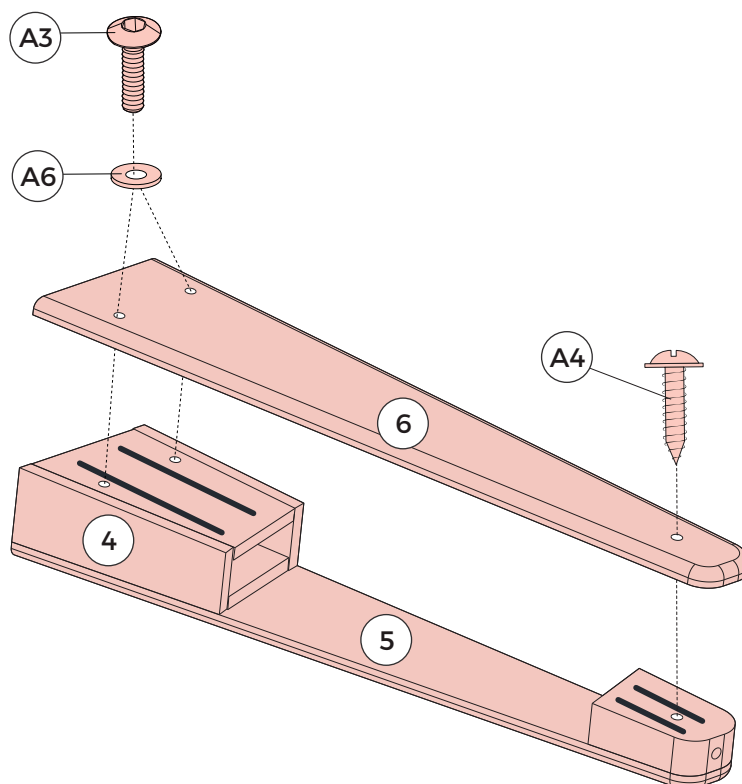
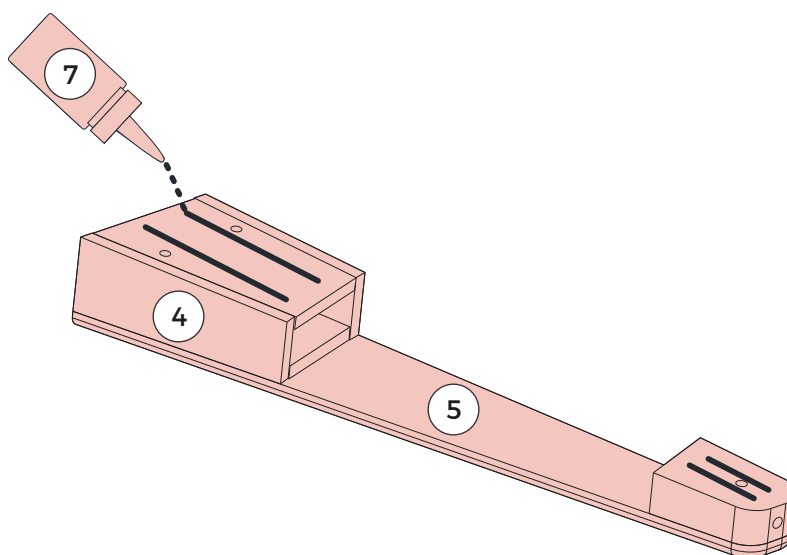
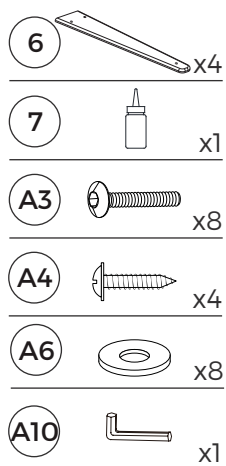







ASSEMBLY

MONTAJE

ASSEMBLAGE

FIG. 5

- 7  x1
- 8  x4
- P3  x16  
Pre-installed
- A1  x8
- A2  x8
- A7  x8
- A10  x1

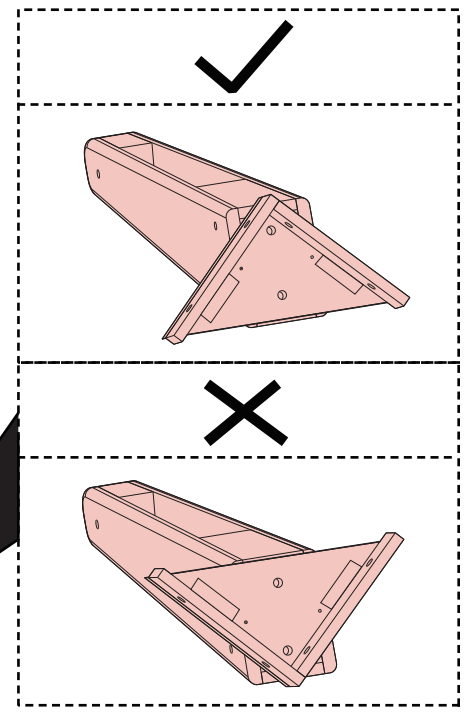
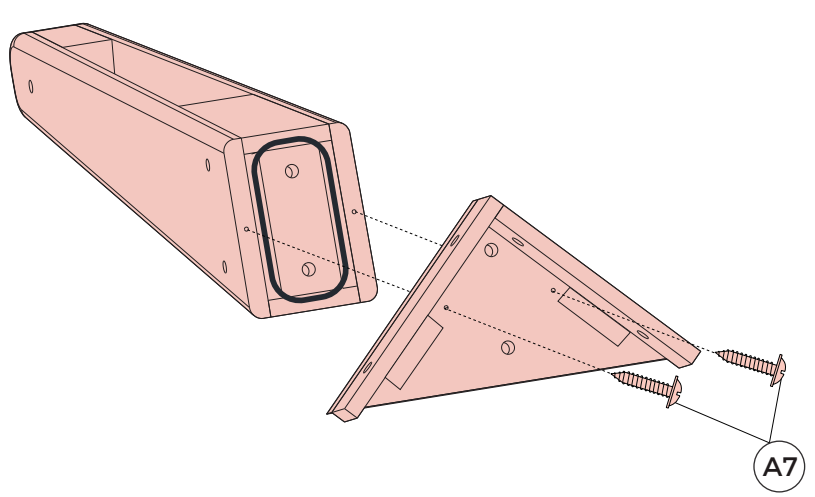
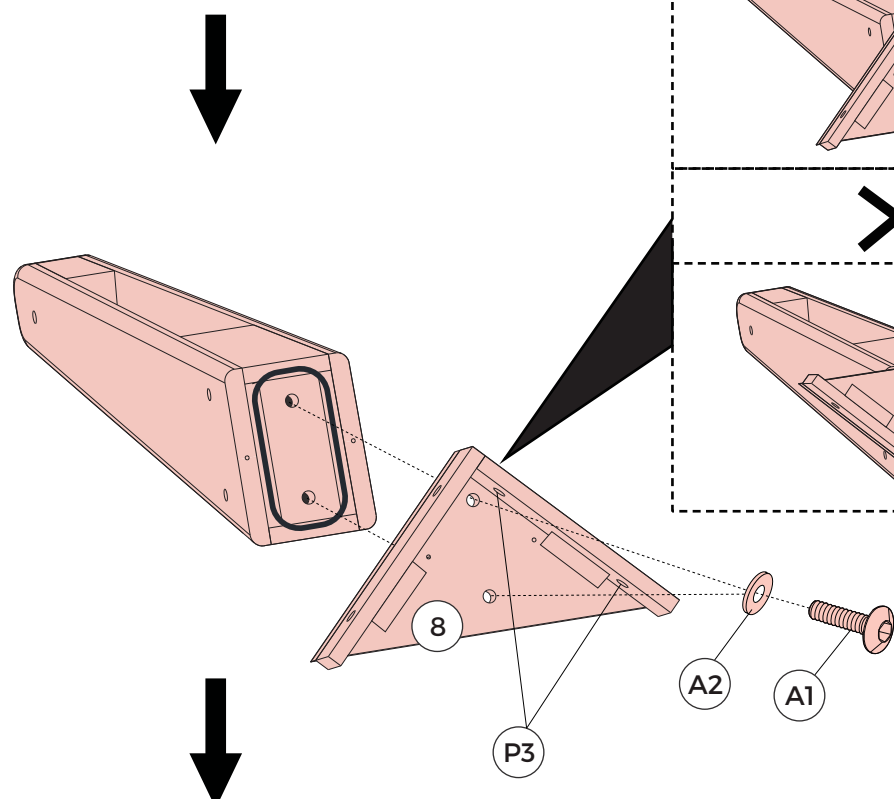
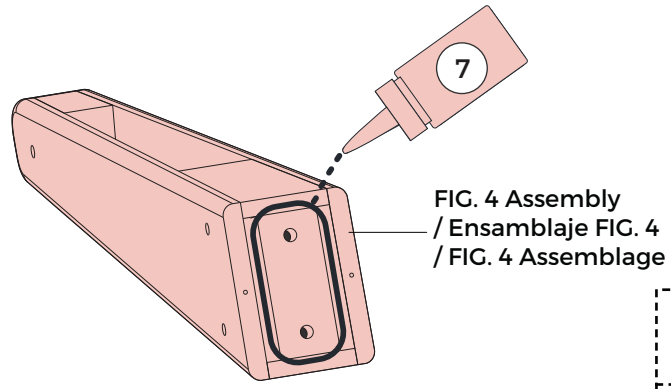



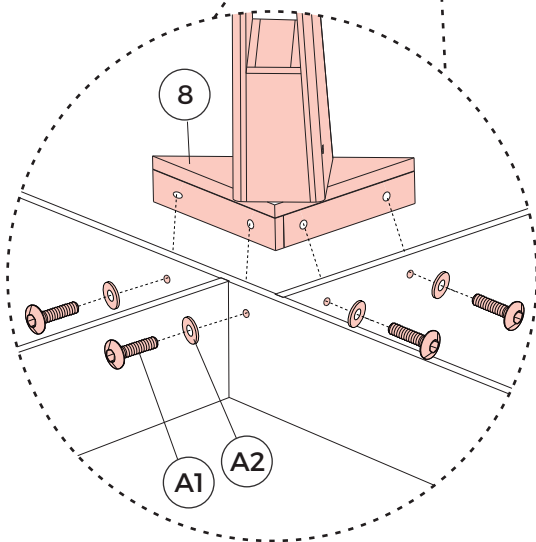
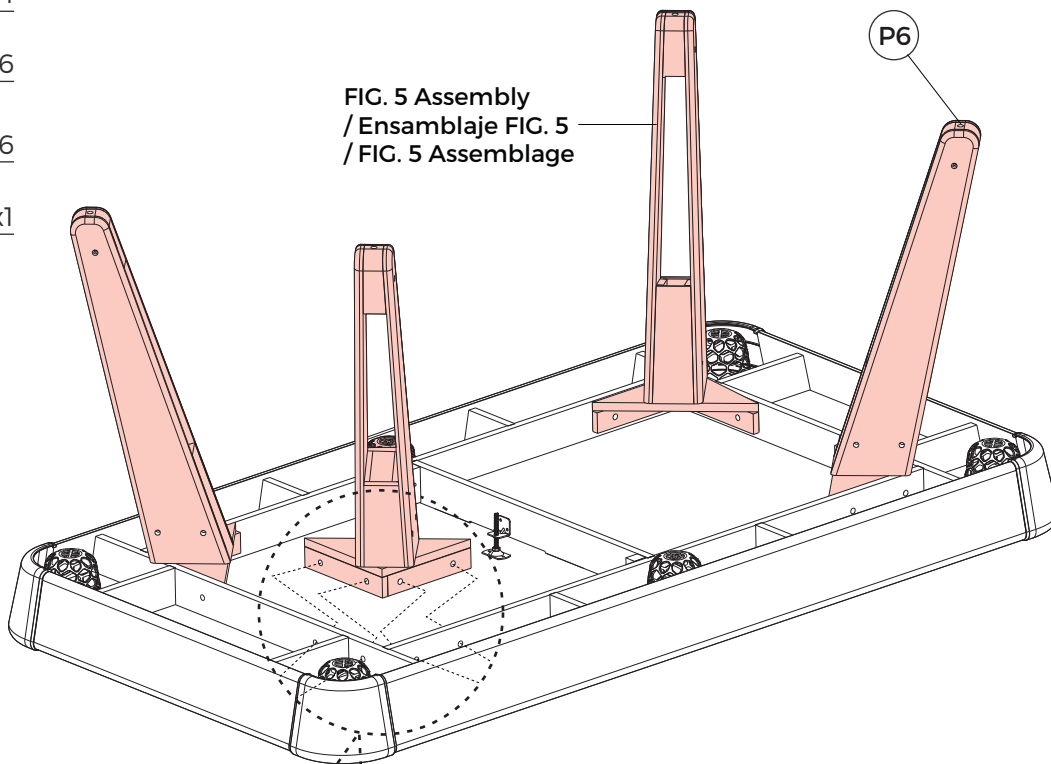

FIG. 6

- P6**  Pre-installed x4
- A1**  x16
- A2**  x16
- A10**  x1



## ASSEMBLY

## MONTAJE

## ASSEMBLAGE

FIG. 7

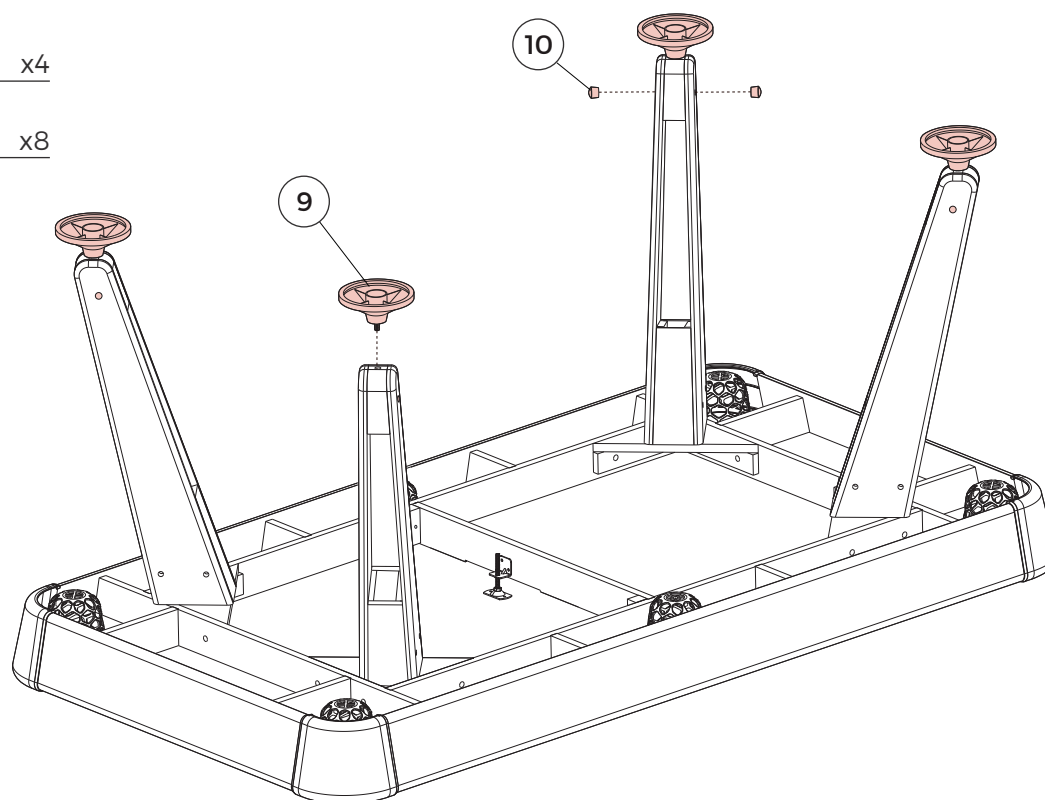
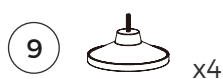

Note: Go back and make sure that all connections are tight.

Nota: Vuelva y asegúrese que todas las conexiones están apretadas.

Note : Revérifiez que toutes les connexions sont bien serrées.

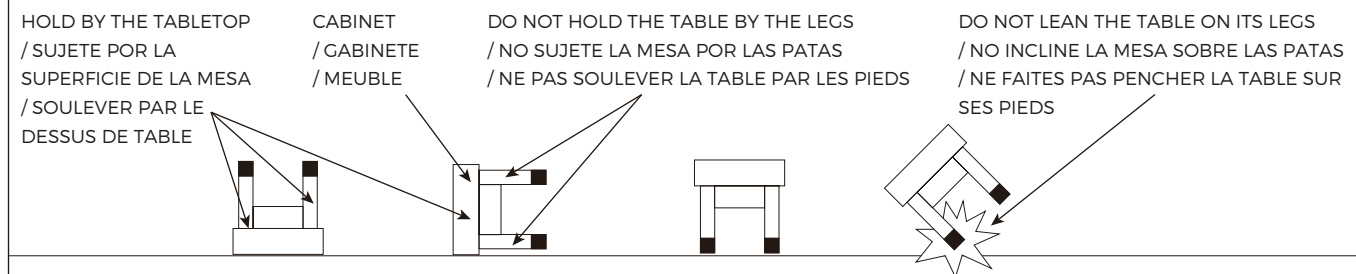

### ⚠ CAUTION

Two strong adults are recommended to turn over the table as shown.

1. Lift the table off the ground.
2. Turn the table over.
3. Place it on all feet at the same time on the ground.

### ⚠ PRECAUCIÓN

Se recomienda voltear la mesa entre 2 adultos como se muestra.

1. Levante la mesa del suelo.
2. Voltee la mesa.
3. Coloque las patas de la mesa sobre el piso al mismo tiempo.

### ⚠ ATTENTION

Il est recommandé que deux adultes forts retournent la table comme indiqué.



1. Soulevez la table du sol.
2. Retournez-la.
3. Placez ses pieds sur le sol simultanément.

ASSEMBLY

MONTAJE

ASSEMBLAGE

FIG.8

- P1**  Pre-installed x4
- P2**  Pre-installed x2
- P7**  Pre-installed x4

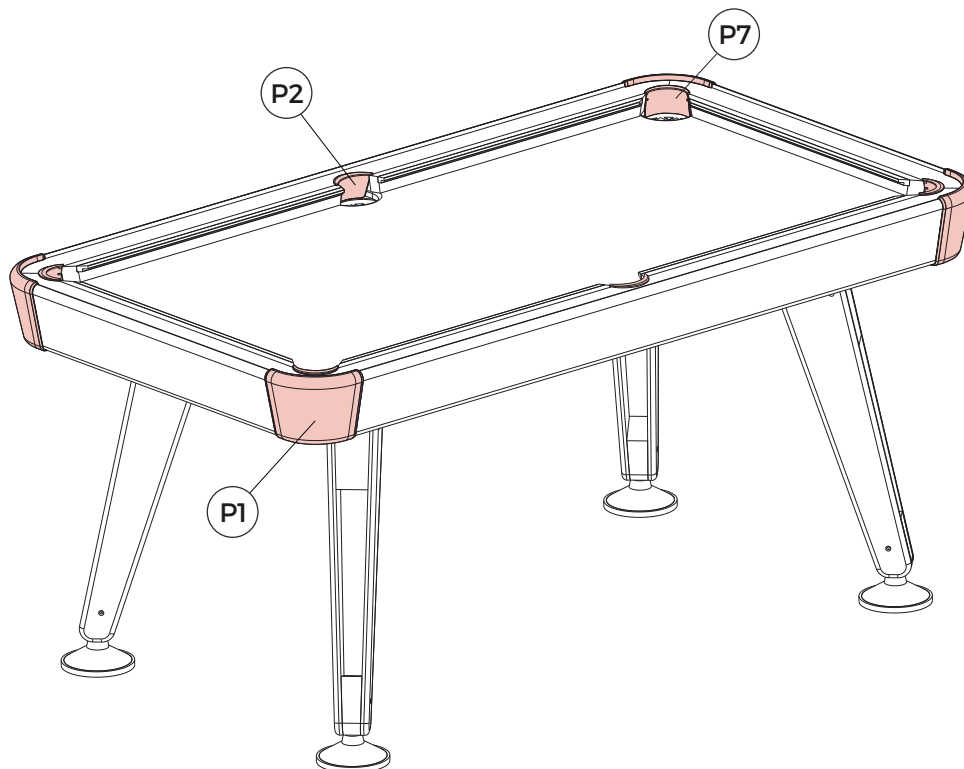

HOW TO LEVEL YOUR TABLE

CÓMO NIVELAR SU MESA

COMMENT LEVER VOTRE TABLE

STEP 1

Level (Not Included)  
/ Nivel (No incluido)  
/ Niveau (Non inclus)

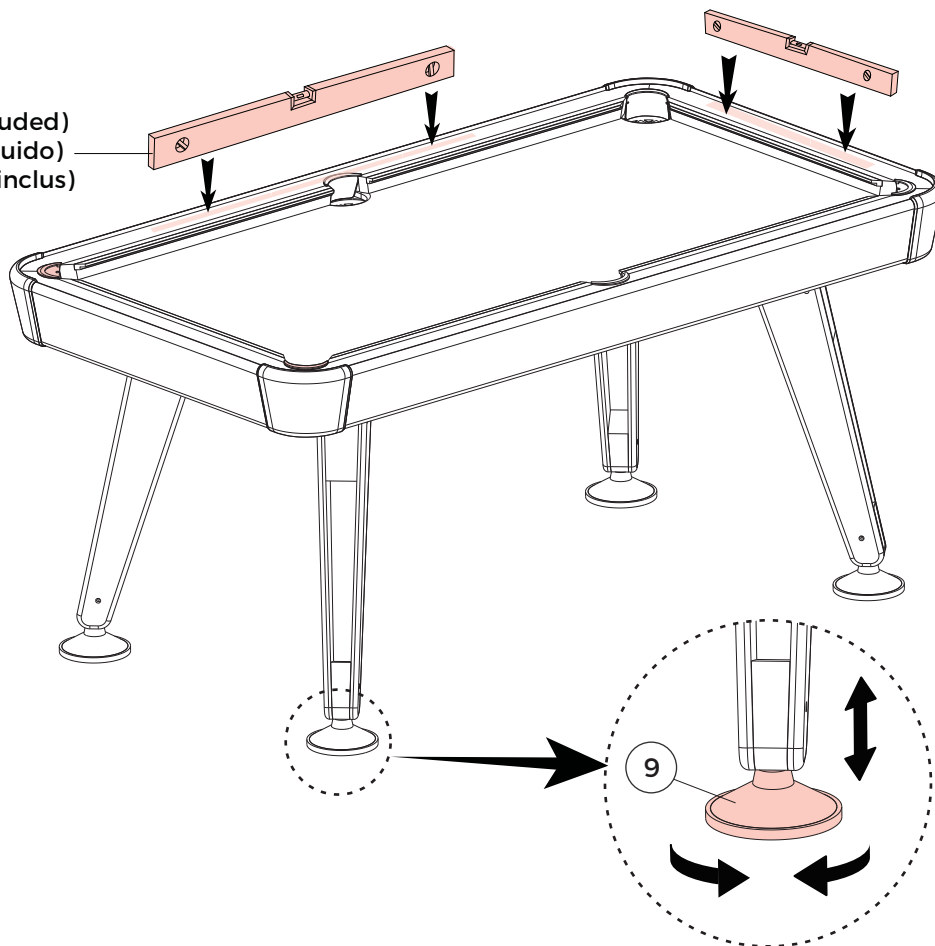

## STEP 2

Level (Not Included)  
/ Nivel (No incluido)  
/ Niveau (Non inclus)

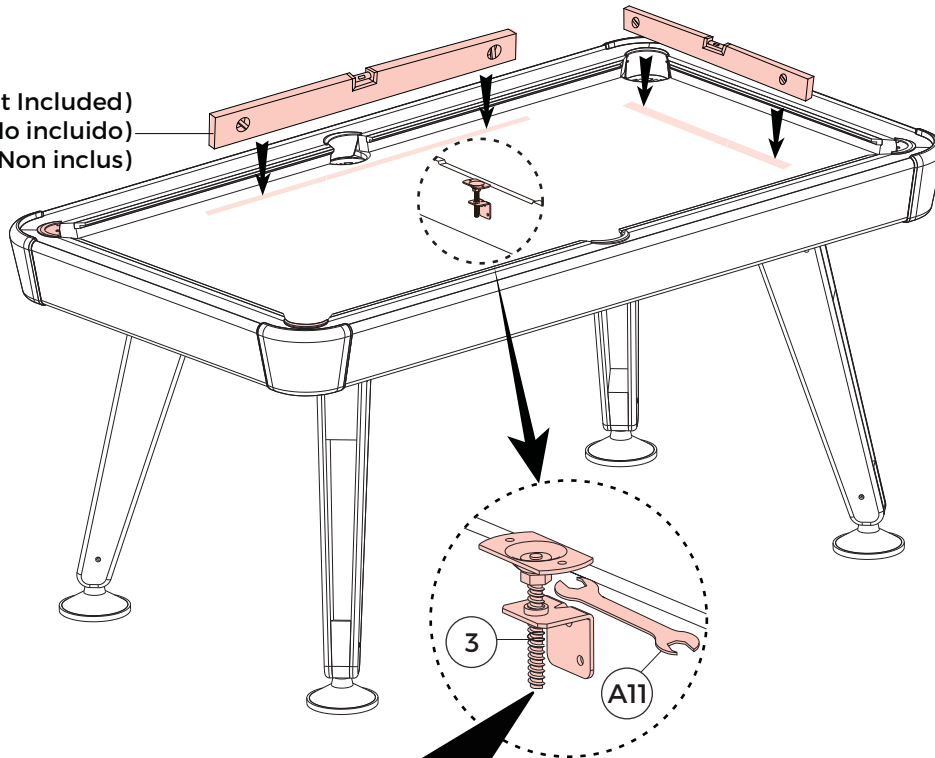

Note: Under the mainframe (1), adjust the adjustable bracket (3) in order to level the playfield of the mainframe.

Nota: Debajo del unidad principal (1), ajuste los corchete regulable (3) por el orden de nivel del campo de juego del unidad principal.

Note : Sous l'Unité centrale (1), réglez les support réglable (3) afin d'aplanir la surface de jeu du l'Unité centrale.

**ADJUST CONCAVE TABLE**  
/ AJUSTAR LA MESA CÓNCAVA  
/ POUR AJUSTER LA TABLE CONCAVE

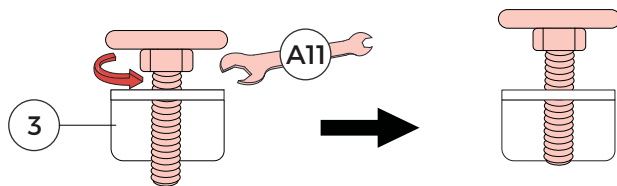

**ADJUST CONVEX TABLE**  
/ AJUSTAR LA MESA CONVEXA  
/ POUR AJUSTER LA TABLE CONVEXE

