

**IMPORTANT PLEASE FOLLOW !**

After unpacking the product, keep the original packaging in case you need to return it. Before starting assembly, check that all parts and hardware are included and in good condition. If anything is missing or damaged, contact the supplier or retailer. **Do not use** non-original parts, modify the item or use power tools as this will void the warranty. Study the instructions thoroughly and follow each step carefully before proceeding to the next.

## TESSA 2 DRAWER DRESSING TABLE NATURAL OAK EFFECT ASSEMBLY INSTRUCTIONS



20KG  
MAX  
WEIGHT



7KG  
MAX DRAWER  
WEIGHT

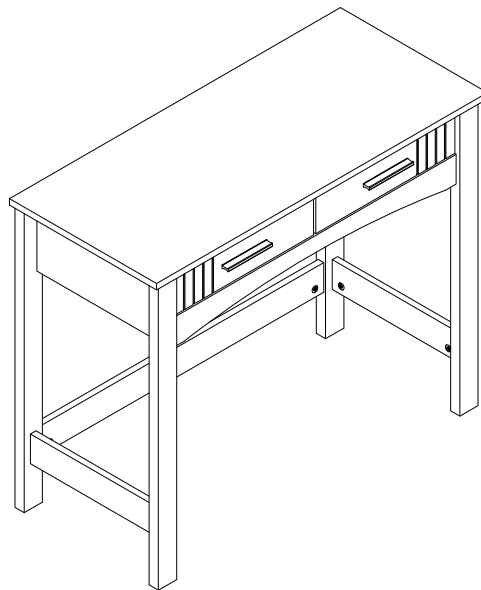

### FOR DOMESTIC USE ONLY FURNITURE CARE AND MAINTENANCE PLEASE READ BEFORE YOU CONTINUE FURTHER

#### Safety

- Keep children away from the area during assembly for safety.
- Use a blanket or sheet on the floor during assembly to protect both the product and your flooring.
- Attach the Anti-Tip strap shown on the final step to the wall. This will prevent the item from tipping over and causing damage or serious injury.
- Follow all recommended weight limits as shown on the assembly instructions.

#### Care

- Avoid dragging or pushing the product, as this may damage the joints and weaken the structure.
- Avoid prolonged exposure to direct sunlight, which can cause fading, discolouration, or drying of natural wood.
- Maintain stable room temperature and humidity, as extreme heat, cold, or moisture may lead to warping, cracking, or swelling.
- Protect the surface from hot or cold items by using placemat's or coasters.
- Please avoid attaching anything sticky to the item, such as Sellotape, stickers, or similar materials, as this can damage the finish.
- Use felt pads under décor, lamps and accessories to prevent scratches.
- Clean spills immediately, blotting rather than rubbing to prevent spreading and surface damage.

#### Maintenance



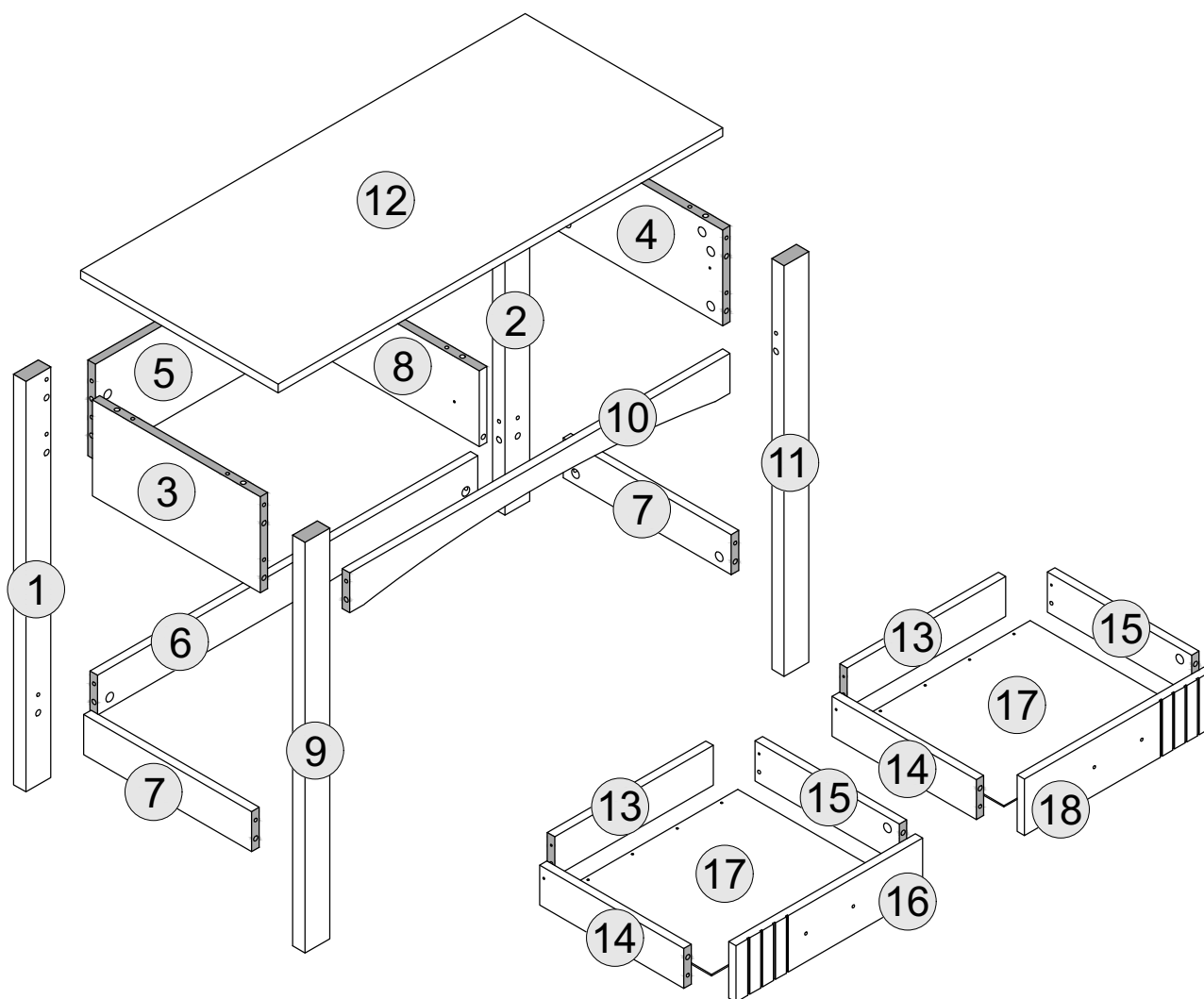





- Periodically tighten all fittings to ensure the furniture remains stable and secure.
- Use only a damp cloth followed by a dry cloth for routine cleaning - avoid detergents, solvents and chemical cleaner.

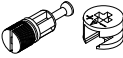
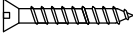

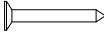
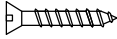
## PART LIST

Part Number	Part Code	Part Description	Quantity	Carton
1	S100-107-025-EU1-01T	Back Leg - Left	1	1/1
2	S100-107-025-EU1-02T	Back Leg - Right	1	1/1
3	S100-107-025-EU1-03T	Side Panel - Left	1	1/1
4	S100-107-025-EU1-04T	Side Panel - Right	1	1/1
5	S100-107-025-EU1-05T	Back Panel	1	1/1
6	S100-107-025-EU1-06T	Back Crossbar	1	1/1
7	S100-107-025-EU1-07T	Side Crossbar	2	1/1
8	S100-107-025-EU1-08T	Centre Panel	1	1/1
9	S100-107-025-EU1-09T	Front Leg - Left	1	1/1
10	S100-107-025-EU1-10T	Front Crossbar	1	1/1
11	S100-107-025-EU1-11T	Front Leg - Right	1	1/1
12	S100-107-025-EU1-12T	Top Panel	1	1/1
13	S100-107-025-EU1-13T	Drawer Back	2	1/1
14	S100-107-025-EU1-14T	Drawer Side - Left	2	1/1
15	S100-107-025-EU1-15T	Drawer Side - Right	2	1/1
16	S100-107-025-EU1-16T	Drawer Front - Left	1	1/1
17	S100-107-025-EU1-17T	Drawer Base	2	1/1
18	S100-107-025-EU1-18T	Drawer Front - Right	1	1/1

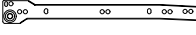
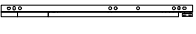
## HARDWARE LIST

A		DOWEL 6 X 30MM	38 PCS
B		CAM BOLT + CAM NUT	33 SETS
C		SCREW M4 X 38MM	4 PCS
D		SCREW M3.5 X 16MM	12 PCS
E		TACK	8 PCS
F		SCREW M4 X 25MM	4 PCS
G		HANDLE	2 PCS
H		SCREW M3.5 X 12MM	16 PCS
I		PLASTIC FOOT	4 PCS
J		DRAWER RUNNER A - L/R	4 PCS
K		DRAWER RUNNER B - L/R	4 PCS
L		ANTI - TIP STRAP	2 PCS
M		SCREW M4 X 16MM	2 PCS

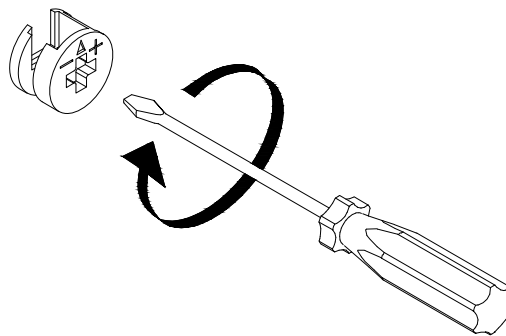

(SCREWDRIVER NOT PROVIDED)

USE A FLAT HEAD SCREWDRIVER TO TIGHTEN THE CAM NUTS. A QUARTER TURN CLOCKWISE IS ALL THAT IS NEEDED.

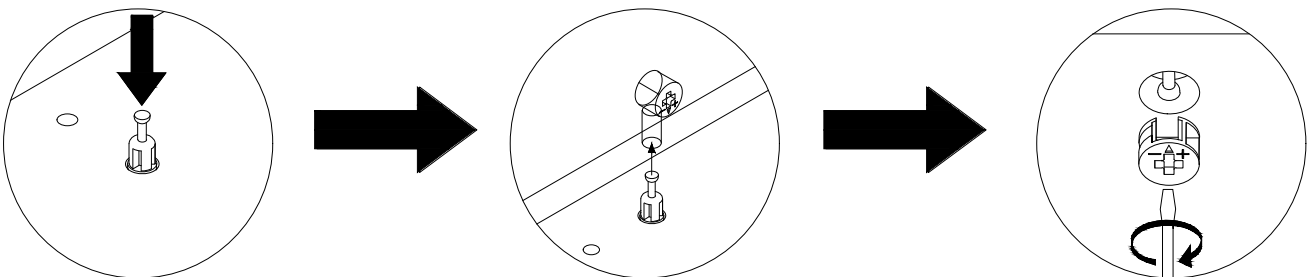

STEP 1 - PUSH CAM BOLT INTO INSERT

STEP 2 - ALIGN THE CAM BOLT WITH THE HOLE AND PUSH TOGETHER UNTIL FLUSH. ( MAKE SURE THE ARROW OF THE CAM LOCK IS POINTING TOWARD ON THE EDGE OF THE PANEL.)

STEP 3 - THE HEAD OF THE BOLT GOES INTO THE WIDE MOUTH OF THE CAM LOCK. YOU THEN TURN THE LOCK SO THE NARROW PART CLOSES OVER THE BOLT.

# STEP 1

**PARTS REQUIRED**

1 - BACK LEG - LEFT	x1
2 - BACK LEG - RIGHT	x1
9 - FRONT LEG - LEFT	x1
11 - FRONT LEG - RIGHT	x1

**HARDWARE REQUIRED**

B		20
---	---	----

**TOOLS REQUIRED**

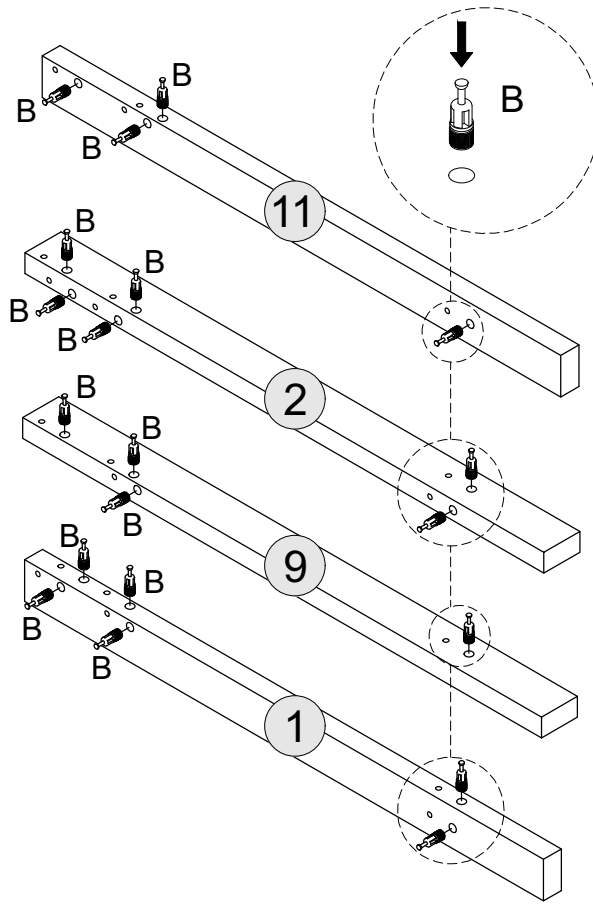



# STEP 2

**PARTS REQUIRED**

8 - CENTRE PANEL	x1
------------------	----

**HARDWARE REQUIRED**

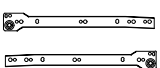
A		04
B		03
H		08
J		02

**TOOLS REQUIRED**

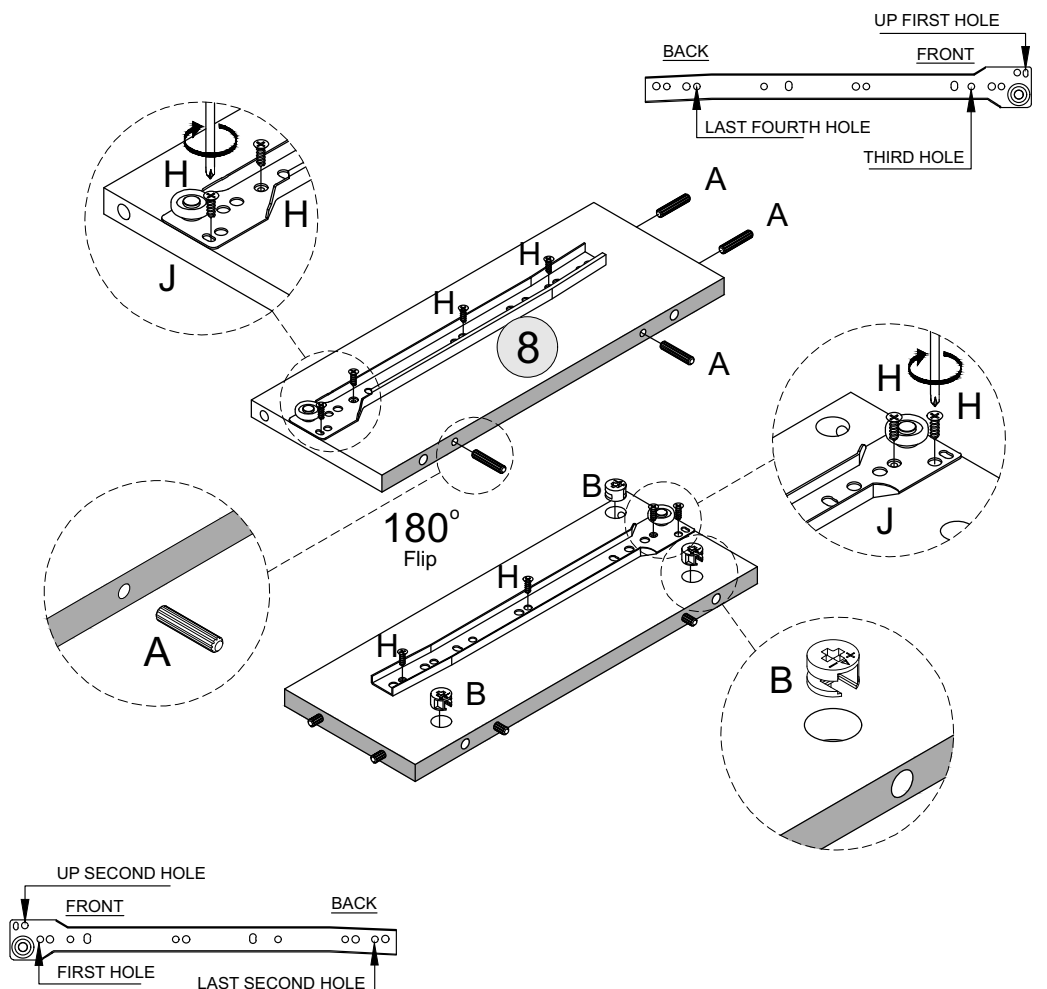
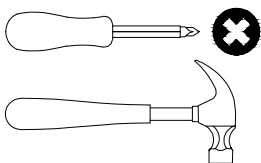



# STEP 3

PARTS REQUIRED

3 - SIDE PANEL - LEFT	x1
4 - SIDE PANEL - RIGHT	x1

HARDWARE REQUIRED

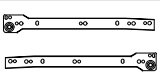
A		12
B		12
H		08
J		02

TOOLS REQUIRED

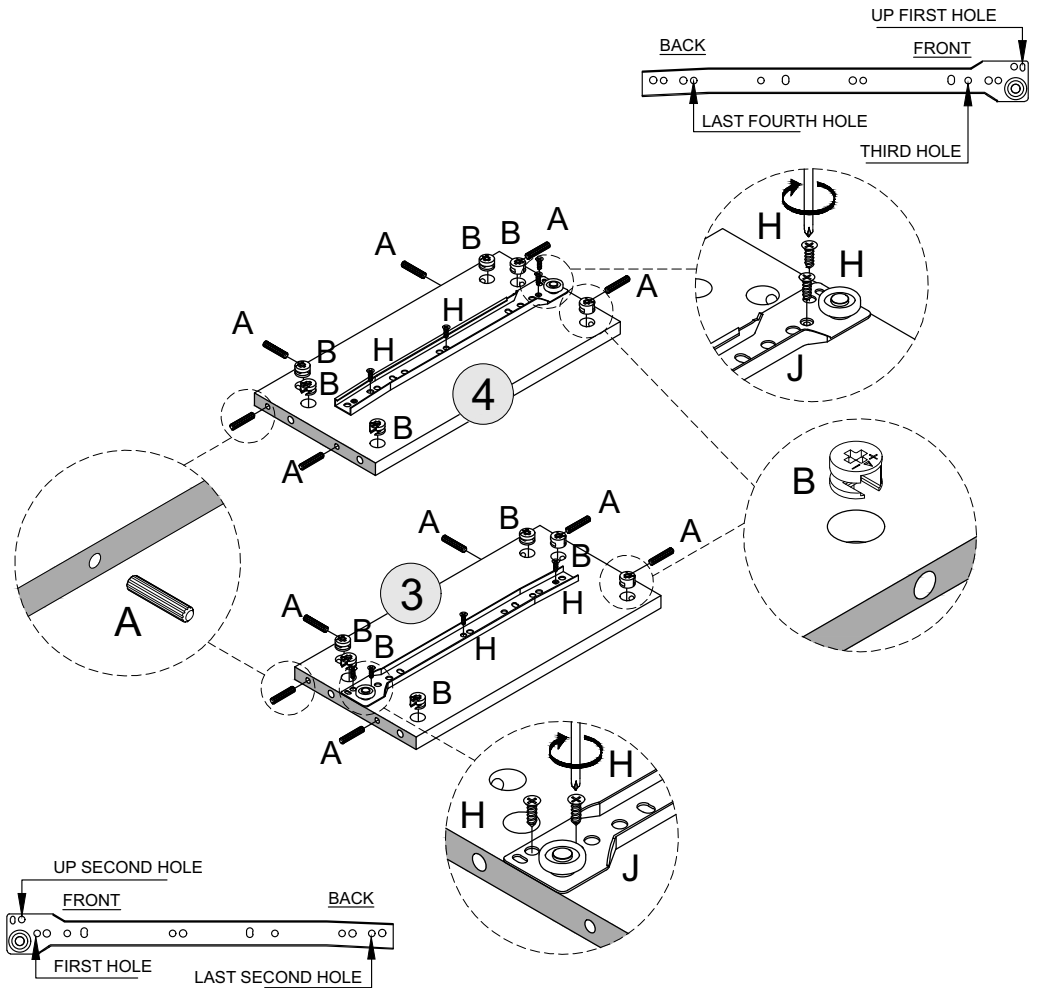
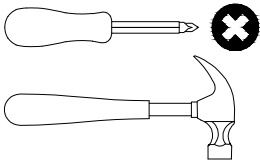

# STEP 4

PARTS REQUIRED

1 - BACK LEG - LEFT	x1
3 - SIDE PANEL - LEFT	x1

HARDWARE REQUIRED

TOOLS REQUIRED

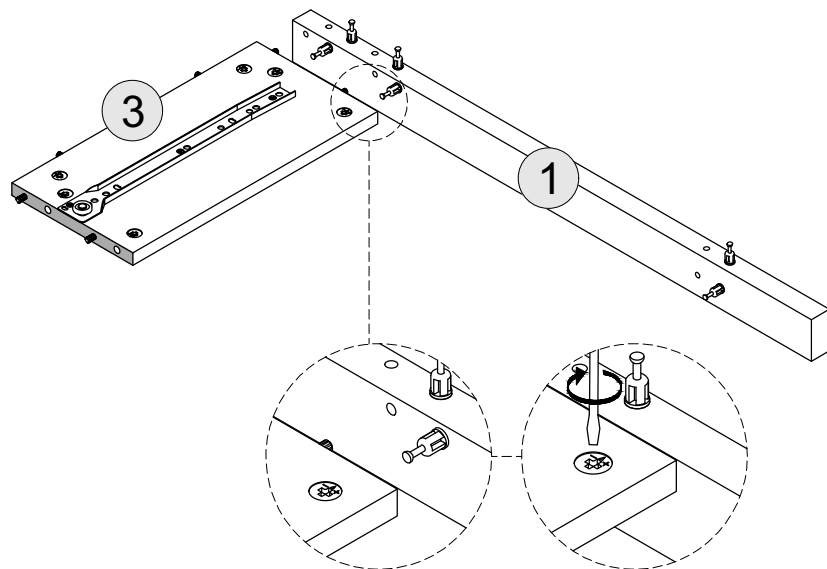
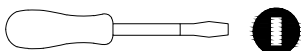

# STEP 5

PARTS REQUIRED

2 - BACK LEG - RIGHT	x1
4 - SIDE PANEL - RIGHT	x1

HARDWARE REQUIRED

TOOLS REQUIRED

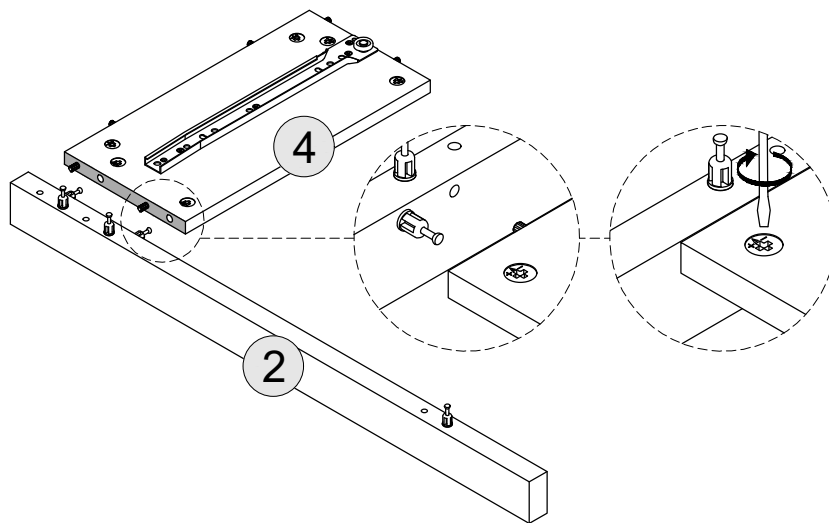
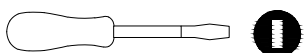

# STEP 6

PARTS REQUIRED

5 - BACK PANEL	x1
6 - BACK CROSSBAR	x1
7 - SIDE CROSSBAR	x2

HARDWARE REQUIRED

A		12
B		12

TOOLS REQUIRED

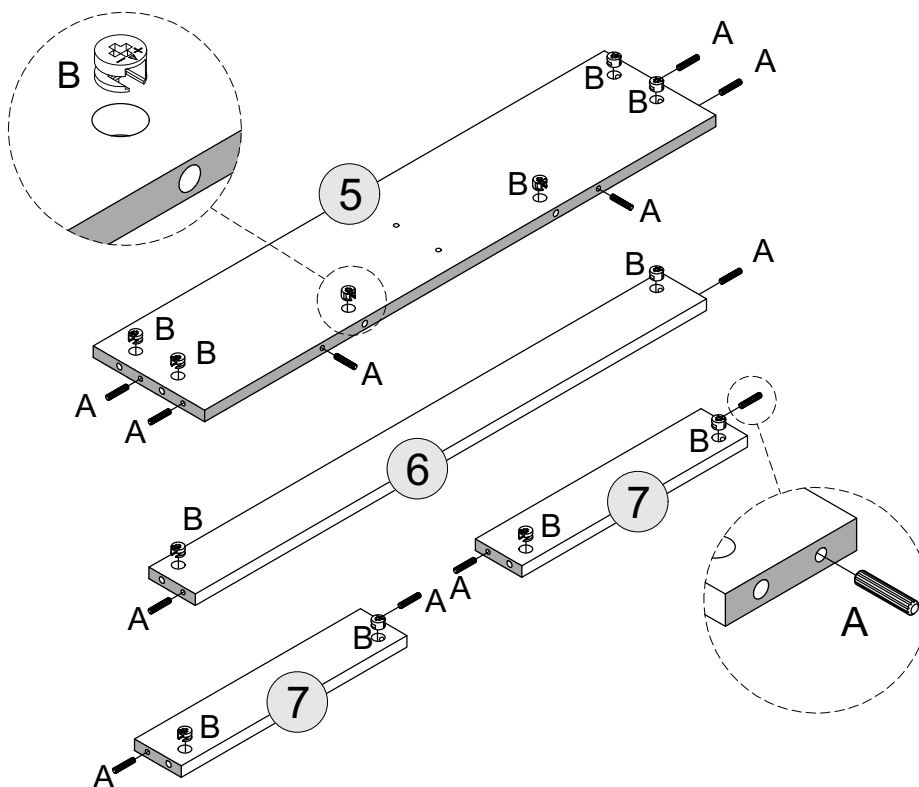
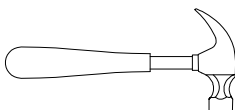

# STEP 7

PARTS REQUIRED

10 - FRONT CROSSBAR x1

12 - TOP PANEL x1

HARDWARE REQUIRED

A  02

B  02

B  09

TOOLS REQUIRED

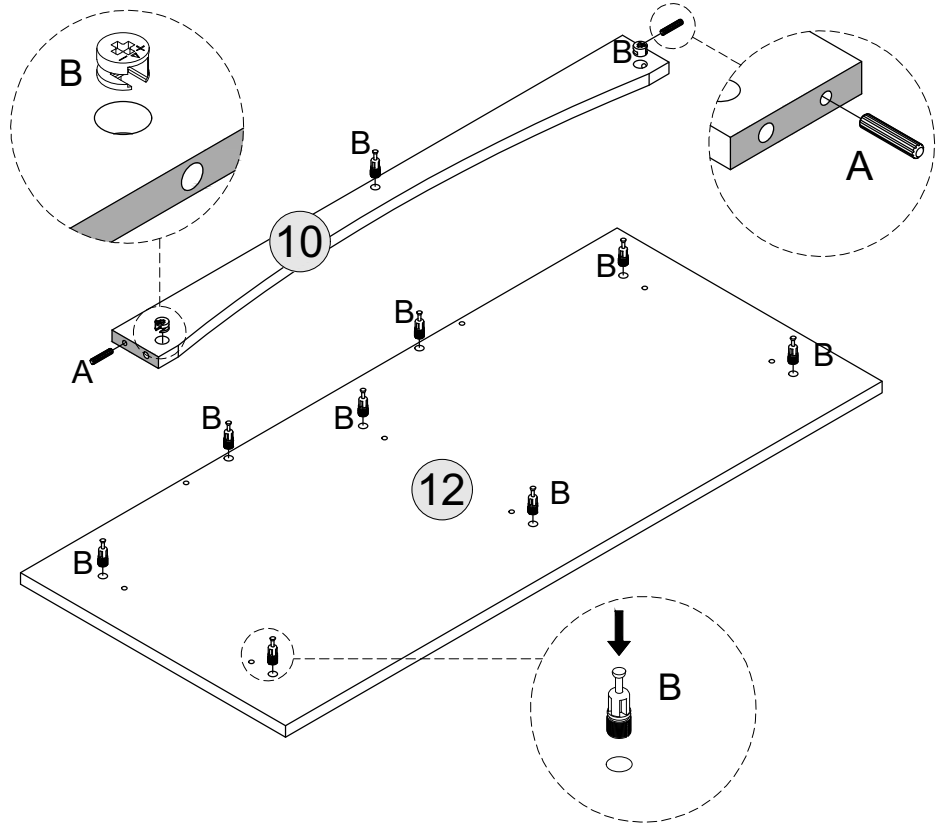
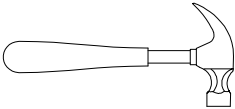

# STEP 8

PARTS REQUIRED

5 - BACK PANEL x1

6 - BACK CROSSBAR x1

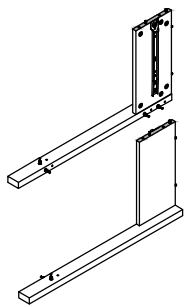

HARDWARE REQUIRED

TOOLS REQUIRED

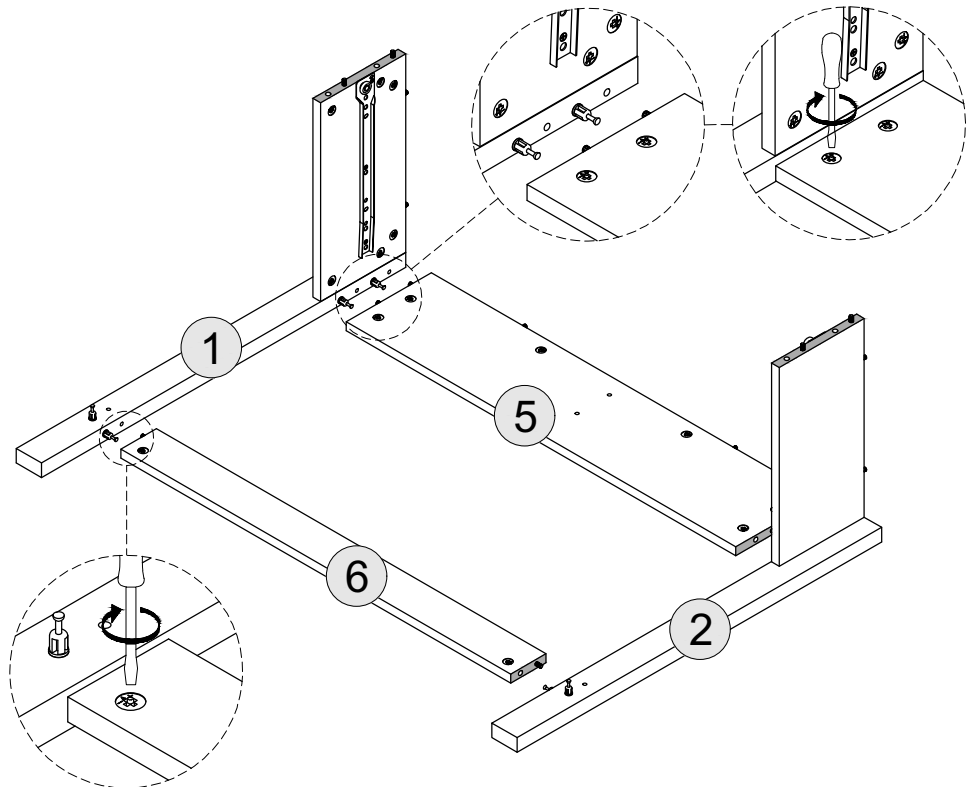
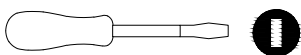

# STEP 9

PARTS REQUIRED

7 - SIDE CROSSBAR	x2
8 - CENTRE PANEL	x1

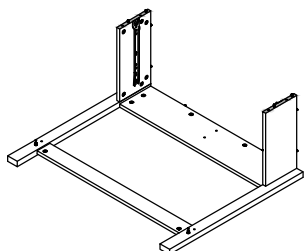

HARDWARE REQUIRED

TOOLS REQUIRED

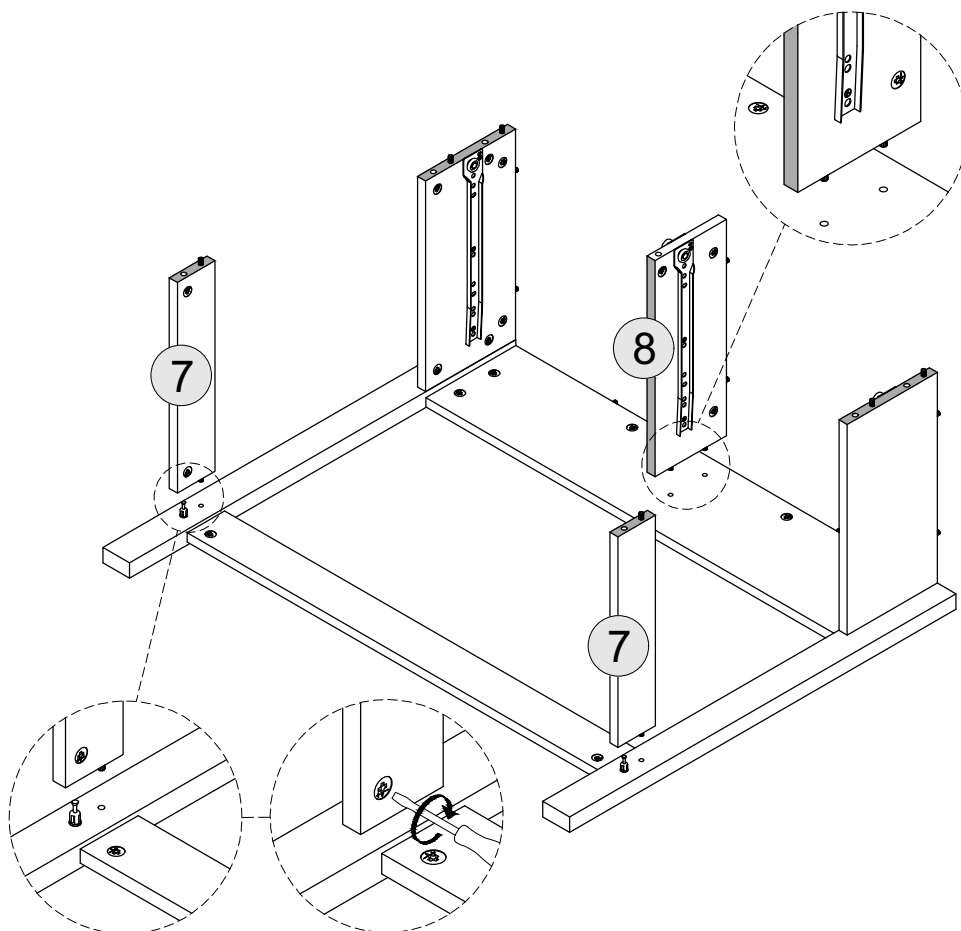
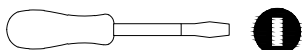

# STEP 10

PARTS REQUIRED

9 - FRONT LEG - LEFT	x1
10 - FRONT CROSSBAR	x1
11 - FRONT LEG - RIGHT	x1

HARDWARE REQUIRED

TOOLS REQUIRED

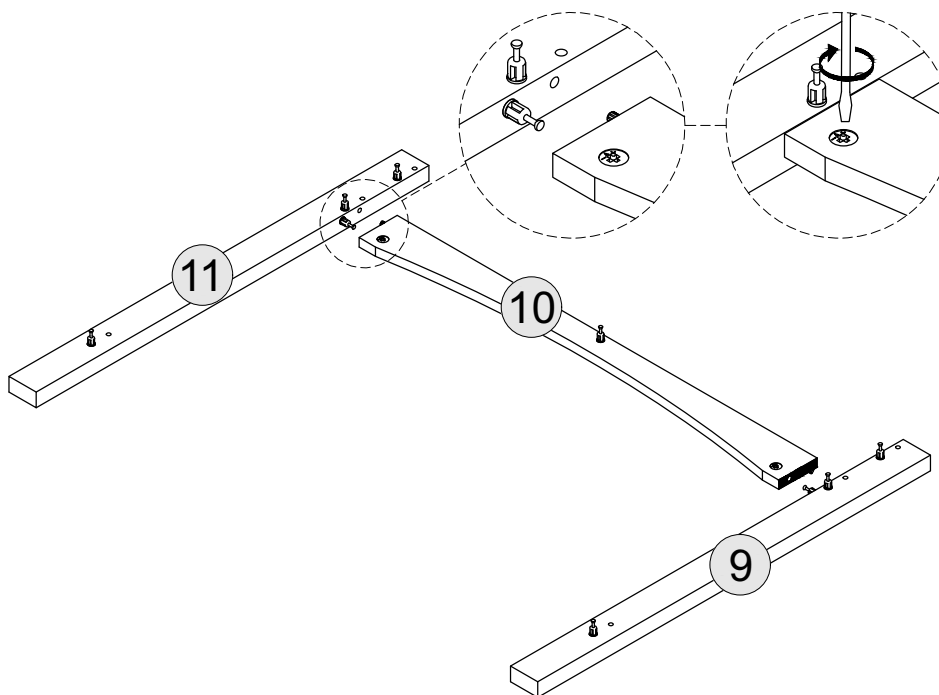
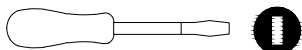

# STEP 11

PARTS REQUIRED

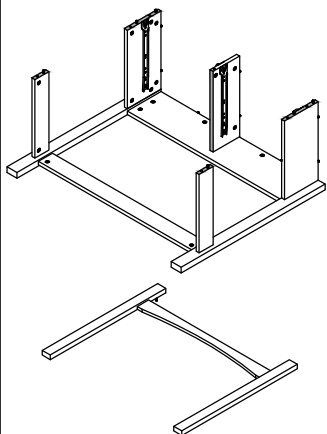

HARDWARE REQUIRED

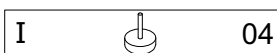

TOOLS REQUIRED

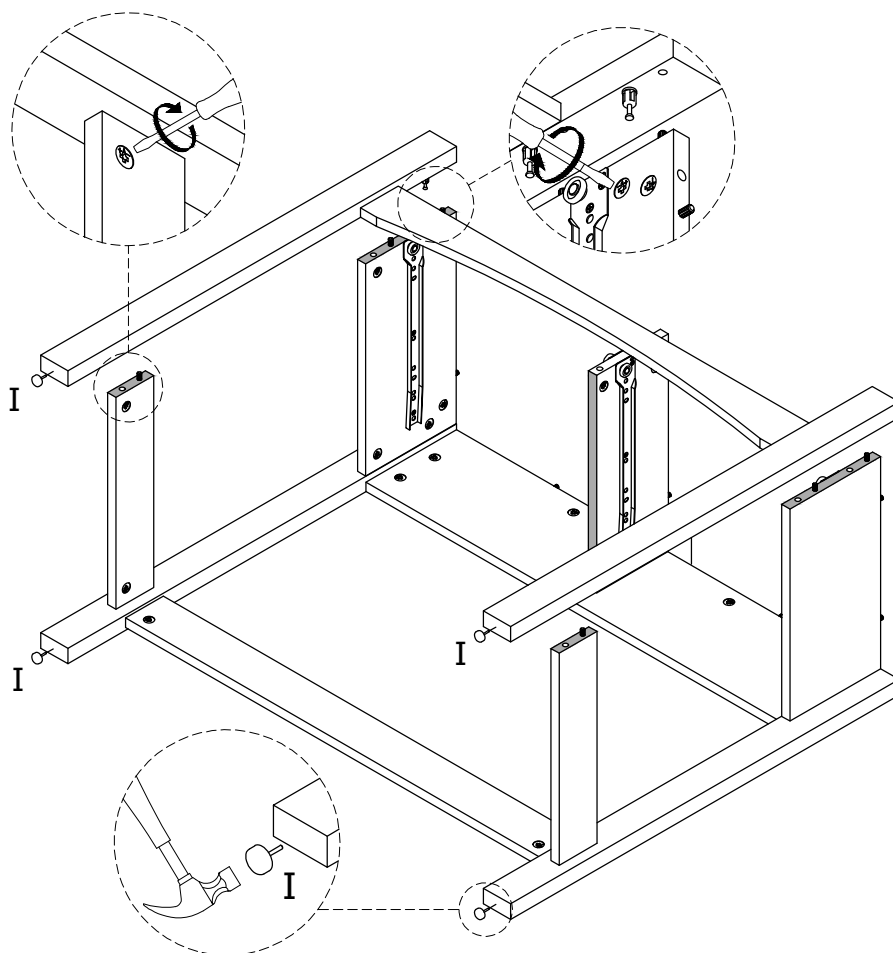
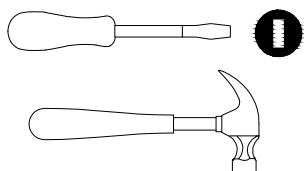

# STEP 12

PARTS REQUIRED

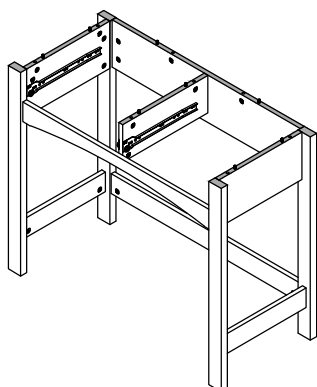

HARDWARE REQUIRED

TOOLS REQUIRED

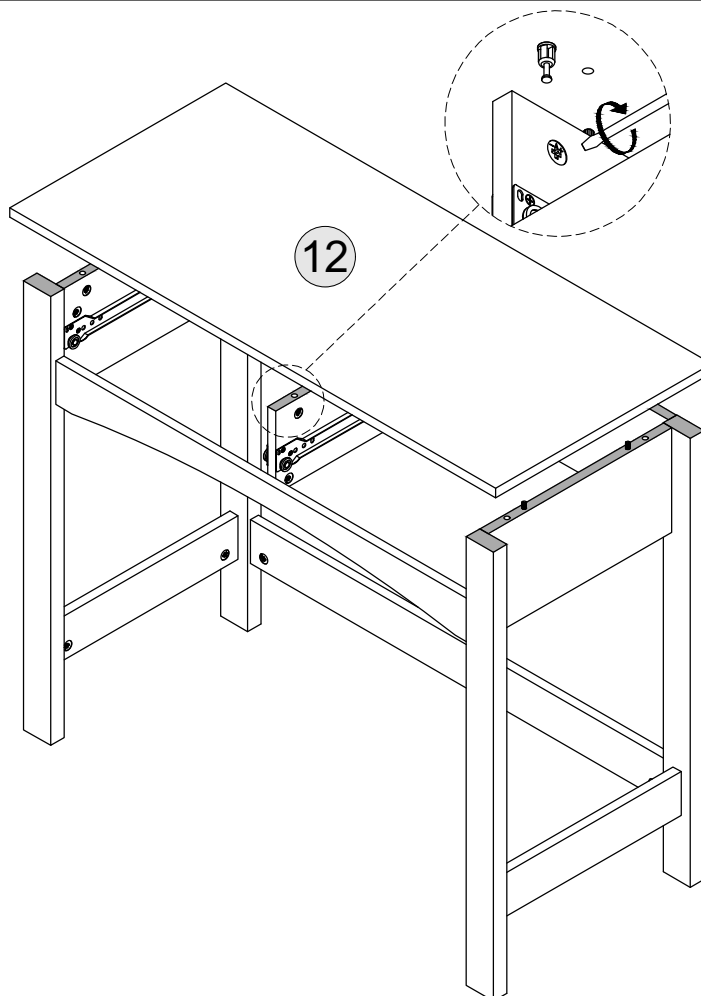
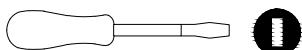



# STEP 13

PART REQUIRED

13 - DRAWER BACK	x2
14 - DRAWER SIDE - LEFT	x2
15 - DRAWER SIDE- RIGHT	x2

HARDWARE REQUIRED

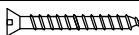
A		08
B		04
C		04

TOOLS REQUIRED

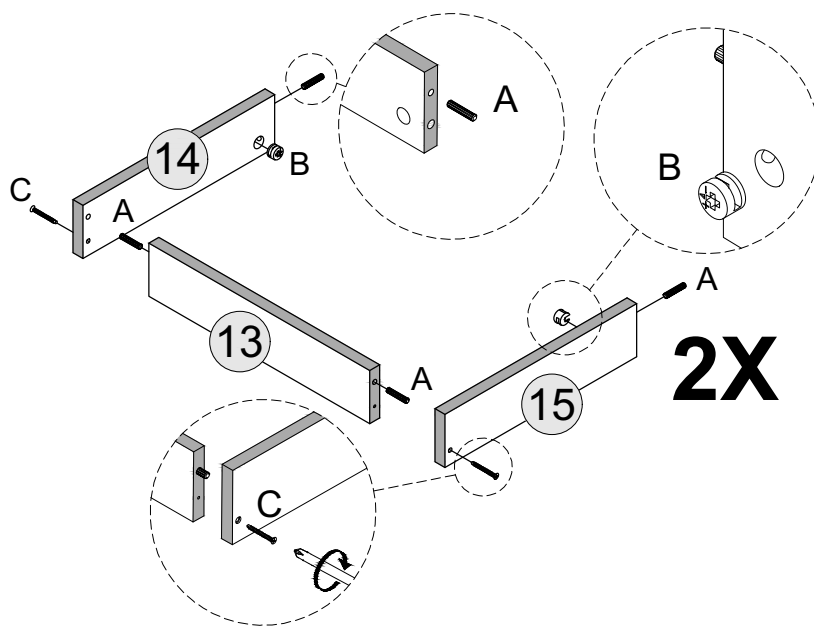
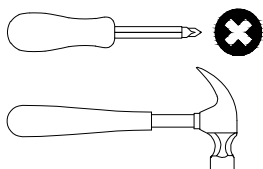

# STEP 14

PART REQUIRED

16 - DRAWER FRONT - LEFT	x1
18 - DRAWER FRONT - RIGHT	x1

HARDWARE REQUIRED

B		04
---	---	----

TOOLS REQUIRED

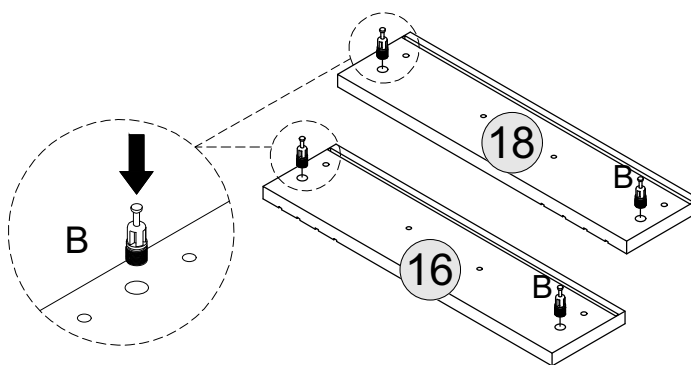

# STEP 15

**PARTS REQUIRED**

16 - DRAWER FRONT - LEFT x1

18 - DRAWER FRONT - RIGHT x1

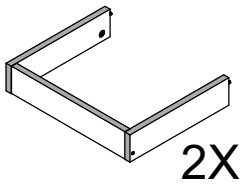

**HARDWARE REQUIRED**

F  04

G  02

**TOOLS REQUIRED**

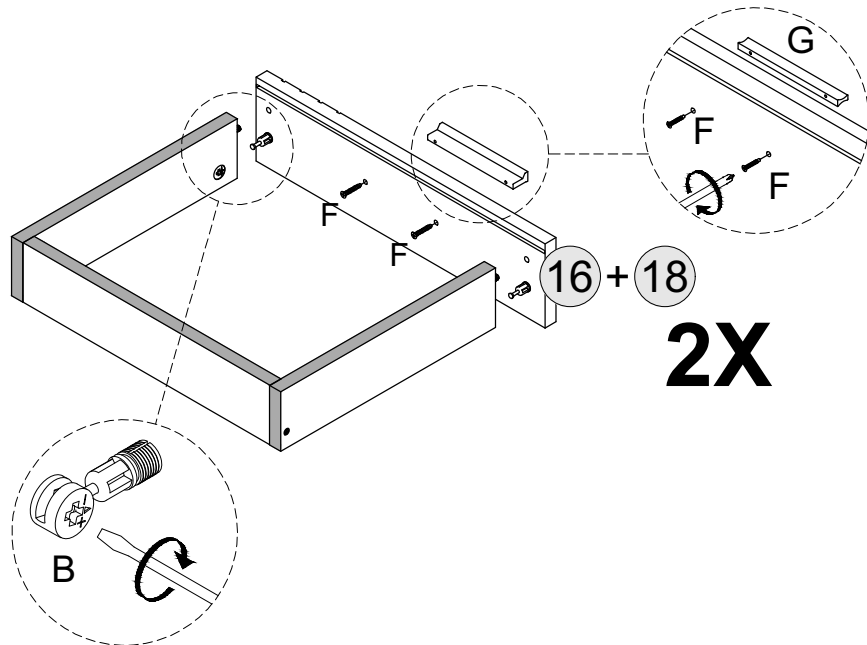
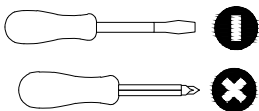

# STEP 16

**IMPORTANT PLEASE FOLLOW !**

Ensure Part 17 is correctly aligned and square with the drawer frame before hammering Fitting E into the back, as any misalignment will affect the final positioning of the drawers once assembled.

**PARTS REQUIRED**

17 - DRAWER BASE x2

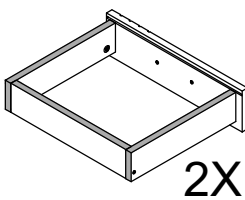

**HARDWARE REQUIRED**

E  08

**TOOLS REQUIRED**

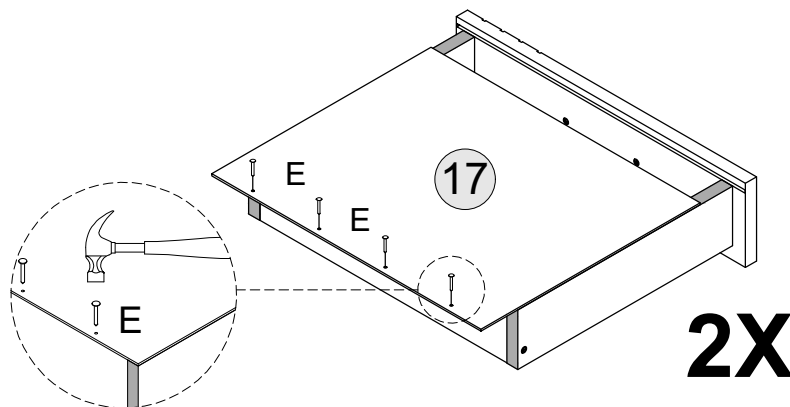
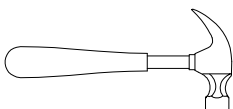

# STEP 17

PART REQUIRED

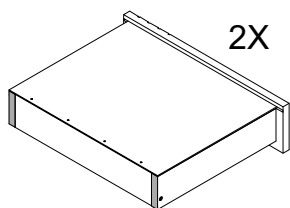

HARDWARE REQUIRED

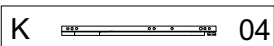
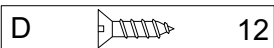

TOOLS REQUIRED

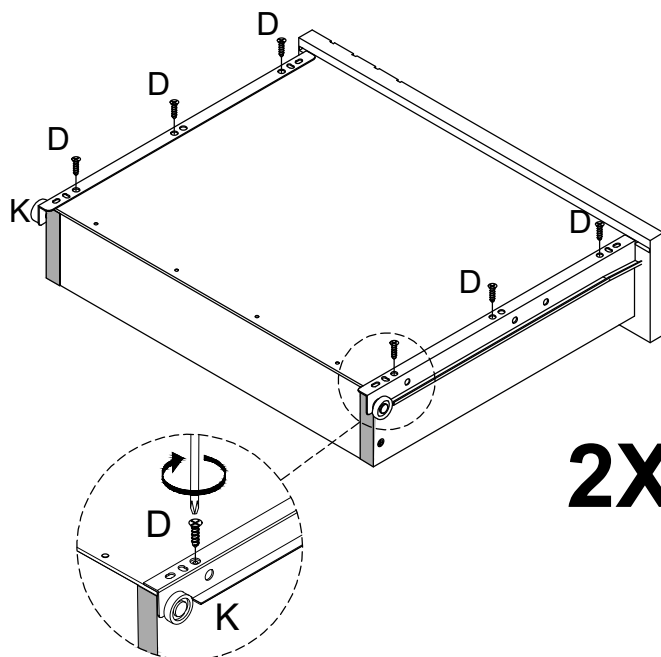
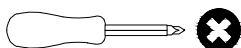

# STEP 18

PARTS REQUIRED

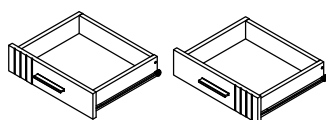
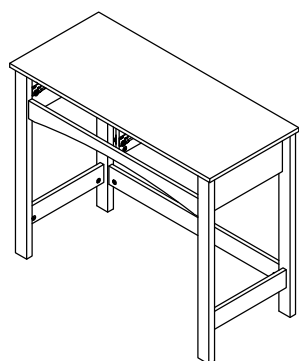

HARDWARE REQUIRED

TOOLS REQUIRED

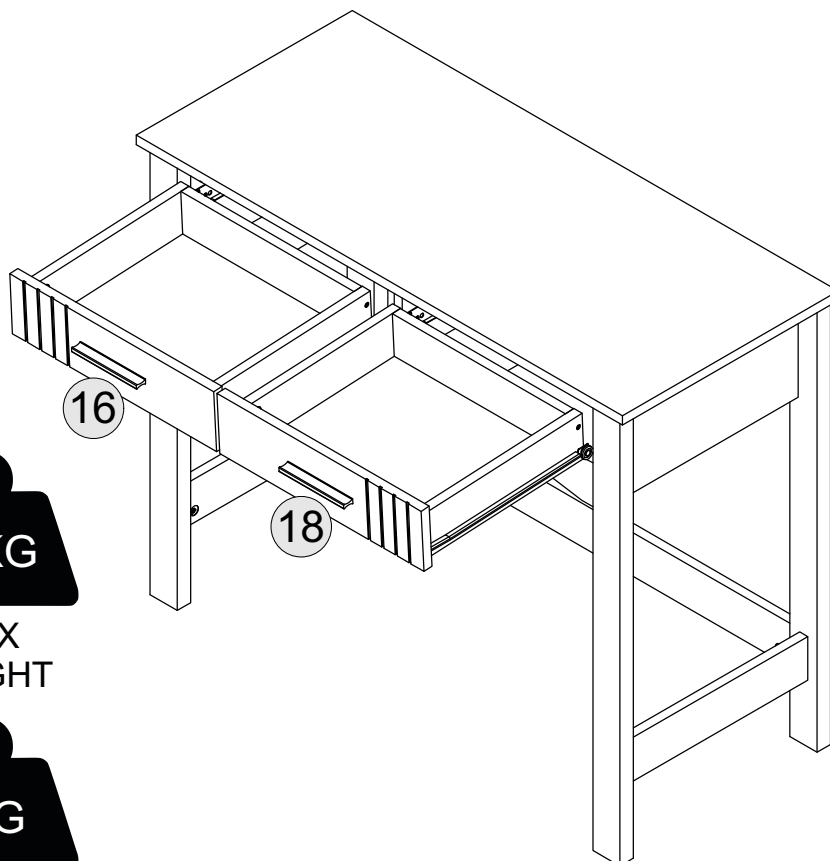

MAX WEIGHT



MAX DRAWER WEIGHT

# STEP 19

PARTS REQUIRED

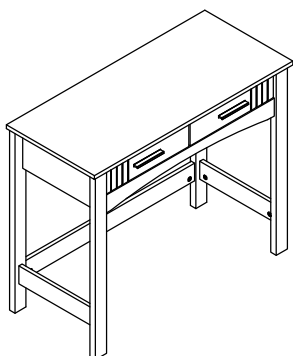

HARDWARE REQUIRED



TOOLS REQUIRED

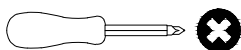

## WARNING

Serious or fatal injuries can occur from furniture tipping over. To prevent the furniture from tipping over we recommend that it is permanently fixed to the wall.

Wall fixings are not supplied with this product as different wall materials require different types of fixing devices. Please make sure you use fixings suitable for the walls in your home.

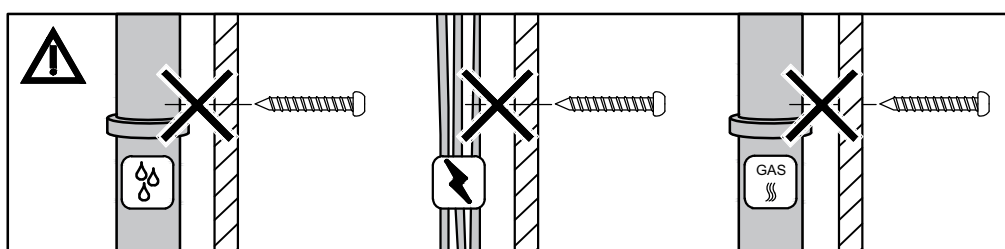
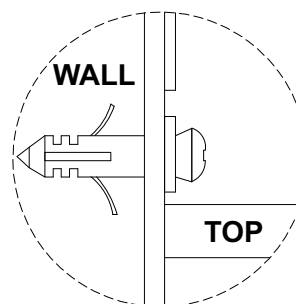
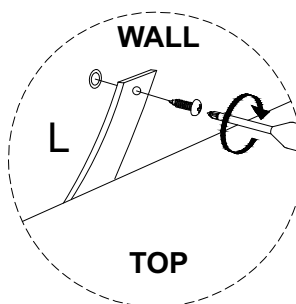
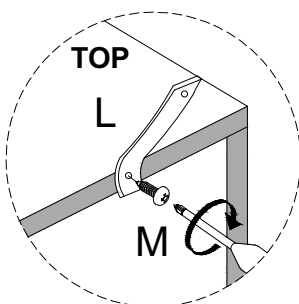
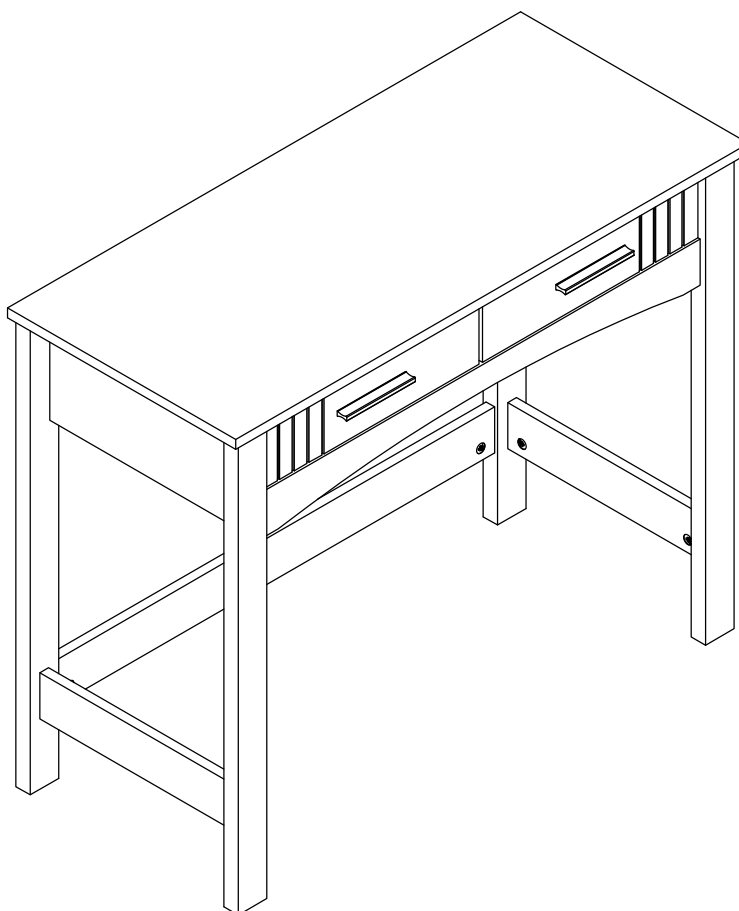

## INFORMATIONS IMPORTANTES (FRENCH)

### IMPORTANTE POUR USAGE DOMESTIQUE UNIQUEMENT VEUILLEZ LIRE AVANT DE CONTINUER

Le produit que vous avez acheté vous offrira de nombreuses années de service si vous suivez les directives pour son assemblage sûr et son entretien et nettoyage périodiques.

Assemblez sur une surface douce et propre.

N'utilisez aucun autre outil que ceux illustrés.

Toutes les clés ou clés Allen nécessaires sont fournies avec le kit de fixation.

N'utilisez en aucun cas un outil électrique pour assembler ce produit. Son utilisation invalidera toute réclamation que vous pourriez avoir et pourrait rendre ce produit dangereux.

Selon la quantité d'utilisation de ce produit, il peut être nécessaire de resserrer les fixations de temps en temps. Cela est tout à fait normal pour tout meuble en kit. Ne serrez pas trop les fixations.

Pour le nettoyage, vous pouvez utiliser un chiffon humide (pas mouillé).

N'utilisez pas de produits de polissage, de détergent ou de nettoyeurs chimiques.

La surface de cet article n'est pas résistante à la chaleur. Utilisez toujours un set de table sous les articles chauds ou froids pour éviter les marques.

### ADVERTENCIA (ANTI-BASCULEMENT)

Des blessures graves, voire mortelles, peuvent survenir en cas de basculement d'un meuble. Pour éviter que le meuble ne bascule, nous recommandons de le fixer de manière permanente au mur.

Les fixations murales ne sont pas fournies avec ce produit, car les différents matériaux de mur nécessitent différents types de dispositifs de fixation. Veuillez vous assurer d'utiliser des fixations adaptées aux murs de votre maison. Veuillez vous référer à la dernière page.

## INFORMACIÓN IMPORTANTE (SPANISH)

### IMPORTANTE SOLO PARA USO DOMÉSTICO LEER ANTES DE CONTINUAR

El producto que ha adquirido le brindará muchos años de servicio si sigue las pautas para su montaje seguro y su mantenimiento y limpieza periódicos.

Ensamble sobre una superficie suave y limpia.

No utilice herramientas distintas a las que se muestran.

Las llaves inglesas o llaves Allen necesarias se incluyen con el kit de accesorios.

No utilice bajo ningún concepto una herramienta eléctrica para ensamblar este producto. Su uso invalidará cualquier reclamo que pueda tener y podría hacer que este producto sea inseguro.

Dependiendo de la cantidad de uso que reciba este producto, puede ser necesario apretar las fijaciones de vez en cuando. Esto es completamente normal para cualquier mueble en paquete plano. No apriete demasiado las fijaciones.

Para la limpieza, puede utilizar un paño húmedo (no mojado). No utilice abrillantadores, detergentes ni limpiadores químicos.

La superficie de este artículo no es resistente al calor. Utilice siempre un mantel individual debajo de los elementos calientes o fríos para evitar marcarlos.

### ADVERTENCIA (ANTI-VUELCO)

El vuelco de los muebles puede provocar lesiones graves o fatales. Para evitar que los muebles se vuelquen, recomendamos fijarlos permanentemente a la pared.

Este producto no incluye fijaciones de pared, ya que los distintos materiales de pared requieren distintos tipos de dispositivos de fijación. Asegúrese de utilizar fijaciones adecuadas para las paredes de su hogar. Veuillez vous référer à la dernière page.

## WICHTIGE INFORMATIONEN (GERMAN)

### WICHTIGUR FÜR DEN HAUSHALTSGEBRAUCH BITTE LESEN SIE, BEVOR SIE FORTFAHREN

Das von Ihnen gekaufte Produkt wird Ihnen viele Jahre lang gute Dienste leisten, wenn Sie die Richtlinien für eine sichere Montage und regelmäßige Wartung und Reinigung befolgen.

Montieren Sie es auf einer weichen, sauberen Oberfläche.

Verwenden Sie keine anderen Werkzeuge als die abgebildeten.

Erforderliche Schraubenschlüssel oder Inbusschlüssel sind im Montagesatz enthalten.

Verwenden Sie unter keinen Umständen ein Elektrowerkzeug zur Montage dieses Produkts. Bei Verwendung erlöschen alle Ansprüche, die Sie haben, und das Produkt kann unsicher werden.

Je nachdem, wie häufig dieses Produkt verwendet wird, kann es erforderlich sein, die Befestigungen von Zeit zu Zeit festzuziehen. Dies ist bei Möbeln aus dem Bausatz völlig normal. Ziehen Sie die Befestigungen nicht zu fest an.

Zum Reinigen können Sie ein feuchtes Tuch verwenden (nicht nass).

Verwenden Sie keine Politur, kein Reinigungsmittel oder chemische Reiniger.

Die Oberfläche dieses Artikels ist nicht hitzebeständig. Verwenden Sie immer eine Unterlage unter heißen oder kalten Gegenständen, um Flecken zu vermeiden.

### WARNUNG (KIPPSCHUTZ)

Durch das Umkippen von Möbeln können schwere oder tödliche Verletzungen entstehen. Um ein Umkippen der Möbel zu verhindern, empfehlen wir, diese dauerhaft an der Wand zu befestigen.

Wandbefestigungen werden nicht mit diesem Produkt mitgeliefert, da unterschiedliche Wandmaterialien unterschiedliche Arten von Befestigungsvorrichtungen erfordern. Bitte stellen Sie sicher, dass Sie Befestigungsvorrichtungen verwenden, die für die Wände in Ihrem Zuhause geeignet sind. Bitte beachten Sie die letzte Seite.

## INFORMAZIONI IMPORTANTI (ITALIAN)

### IMPORTANTE, SOLO PER USO DOMESTICO SI PREGA DI LEGGERE PRIMA DI CONTINUARE OLTRE

Il prodotto che hai acquistato ti garantirà molti anni di servizio se seguire le linee guida per il suo montaggio sicuro e periodico manutenzione e pulizia.

Montare su una superficie morbida e pulita.

Non utilizzare strumenti diversi da quelli mostrati.

Eventuali chiavi e chiavi a brugola necessarie sono incluse nel kit di raccordi.

Non utilizzare per nessun motivo un utensile elettrico per assemblare questo prodotto. Suo l'uso invaliderà qualsiasi reclamo tu possa avere e potresti avanzare su questo prodotto pericoloso.

A seconda della quantità di utilizzo che questo prodotto riceve, potrebbe essere necessario stringere di tanto in tanto i fissaggi.

Questo è completamente

normalmente per qualsiasi mobile flat pack. Non stringere eccessivamente il fissaggio.

Per la pulizia è possibile utilizzare un panno umido (non bagnato).

Non usare smalti, detersivi o detergenti chimici.

La superficie di questo articolo non è resistente al calore. Usa sempre una tovaglietta sotto oggetti caldi o freddi per evitare segni.

### AVVERTIMENTO (ANTIRIBALTAMENTO)

Il ribaltamento dei mobili può provocare lesioni gravi e mortali. A evitare che i mobili si ribaltino, si consiglia di farlo fissato permanentemente al muro.

I fissaggi a parete non sono forniti con questo prodotto in quanto parete diversa i materiali richiedono diversi tipi di dispositivi di fissaggio. Per favore, fallo assicurati di utilizzare fissaggi adatti alle pareti della tua casa. Si prega di fare riferimento all'ultima pagina.

**IMPORTANT PLEASE FOLLOW !**

After unpacking the product, keep the original packaging in case you need to return it. Before starting assembly, check that all parts and hardware are included and in good condition. If anything is missing or damaged, contact the supplier or retailer. **Do not use** non-original parts, modify the item or use power tools as this will void the warranty. Study the instructions thoroughly and follow each step carefully before proceeding to the next.

# TESSA DRESSING TABLE MIRROR NATURAL OAK EFFECT/GLASS ASSEMBLY INSTRUCTIONS

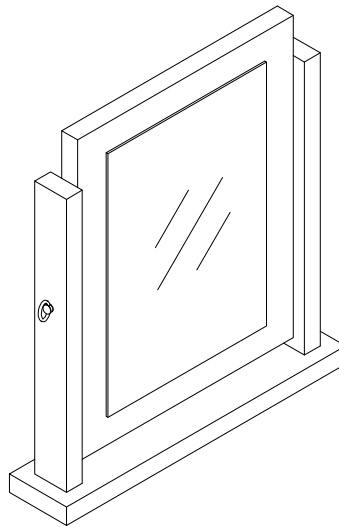

## FOR DOMESTIC USE ONLY FURNITURE CARE AND MAINTENANCE PLEASE READ BEFORE YOU CONTINUE FURTHER

### Safety

- Keep children away from the area during assembly for safety.
- Use a blanket or sheet on the floor during assembly to protect both the product and your flooring.
- Attach the Anti-Tip strap shown on the final step to the wall. This will prevent the item from tipping over and causing damage or serious injury.
- Follow all recommended weight limits as shown on the assembly instructions.

### Care

- Avoid dragging or pushing the product, as this may damage the joints and weaken the structure.
- Avoid prolonged exposure to direct sunlight, which can cause fading, discolouration, or drying of natural wood.
- Maintain stable room temperature and humidity, as extreme heat, cold, or moisture may lead to warping, cracking, or swelling.
- Protect the surface from hot or cold items by using placemat's or coasters.
- Please avoid attaching anything sticky to the item, such as Sellotape, stickers, or similar materials, as this can damage the finish.
- Use felt pads under décor, lamps and accessories to prevent scratches.
- Clean spills immediately, blotting rather than rubbing to prevent spreading and surface damage.

### Maintenance

- Periodically tighten all fittings to ensure the furniture remains stable and secure.
- Wood - Use only a damp cloth followed by a dry cloth for routine cleaning - avoid detergents, solvents and chemical cleaner.
- Glass - Clean with a standard glass cleaner; avoid abrasive pads.
- Metal - Wipe with a damp cloth and dry immediately to prevent water spots or corrosion.

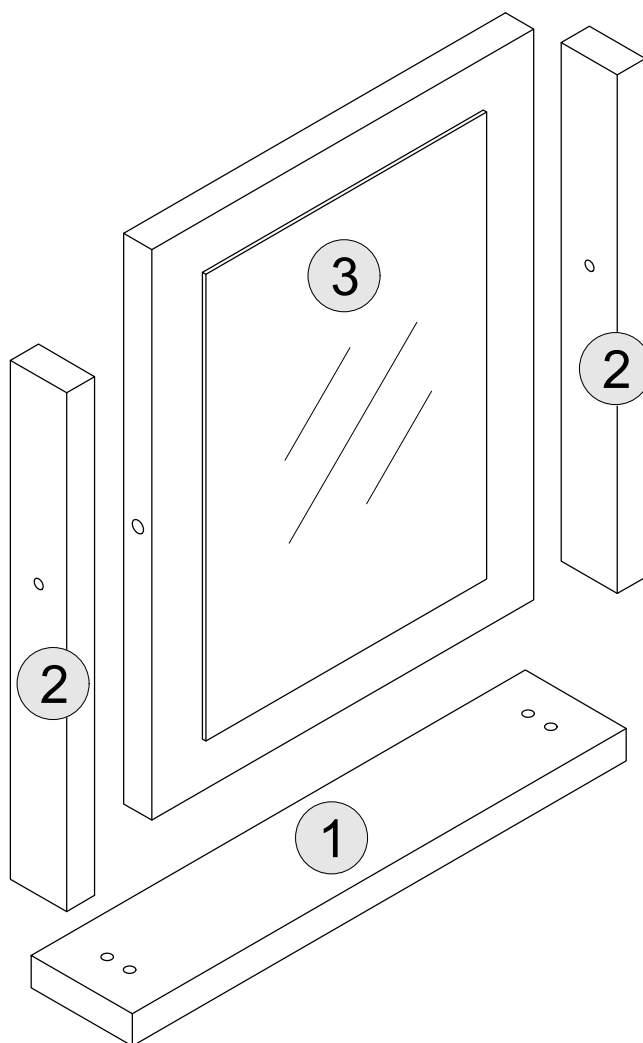

## PART LIST

<u>Part Number</u>	<u>Part Code</u>	<u>Part Description</u>	<u>Quantity</u>	<u>Carton</u>
1	S100-107-025-EU1-01M	Bottom Panel	1	1/1
2	S100-107-025-EU1-02M	Side Panel	2	1/1
3	S100-107-025-EU1-03M	Mirrored Panel	1	1/1

## HARDWARE LIST

A		BOLT 7x60MM	4 PCS
B		SCREW	2 PCS
C		ALLEN KEY	1 PC

## STEP 1

### PARTS REQUIRED

1 - BOTTOM PANEL x1

2 - SIDE PANEL x2

### HARDWARE REQUIRED

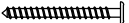
A  04

### TOOLS REQUIRED

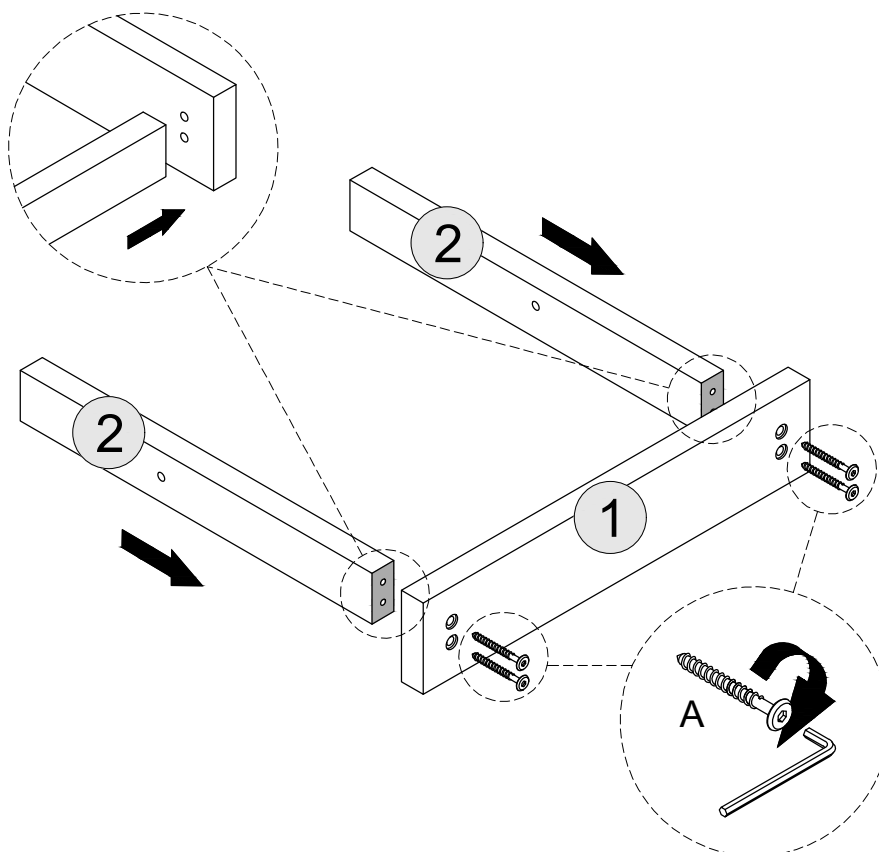

## STEP 2

PARTS REQUIRED

3 - MIRRORED PANEL x1

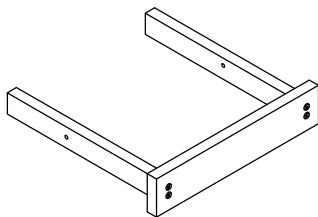

HARDWARE REQUIRED

B  02

TOOLS REQUIRED

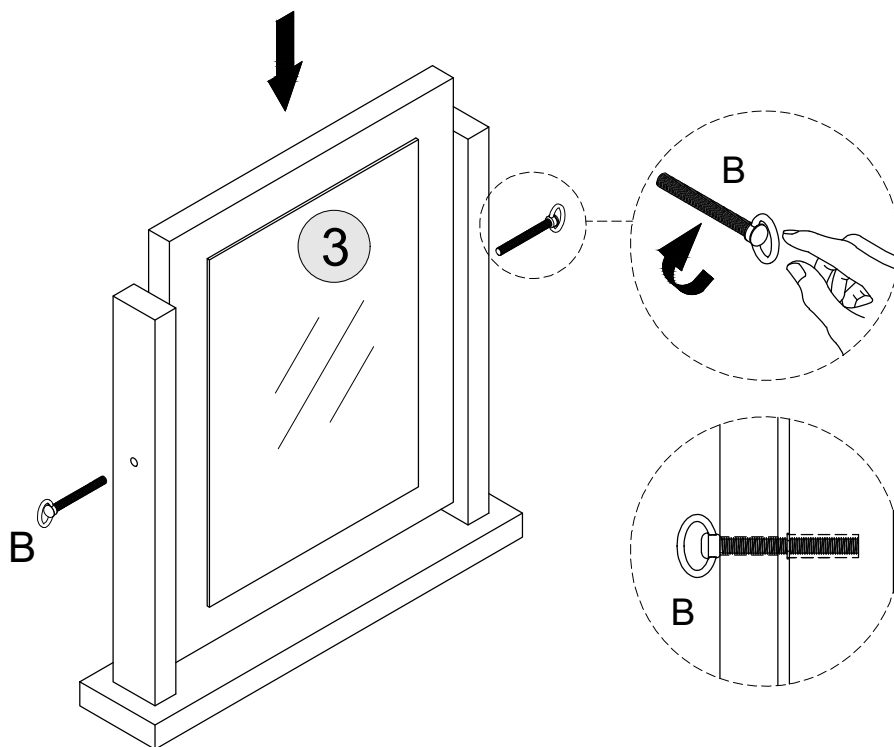

## STEP 3

PARTS REQUIRED

HARDWARE REQUIRED

TOOLS REQUIRED

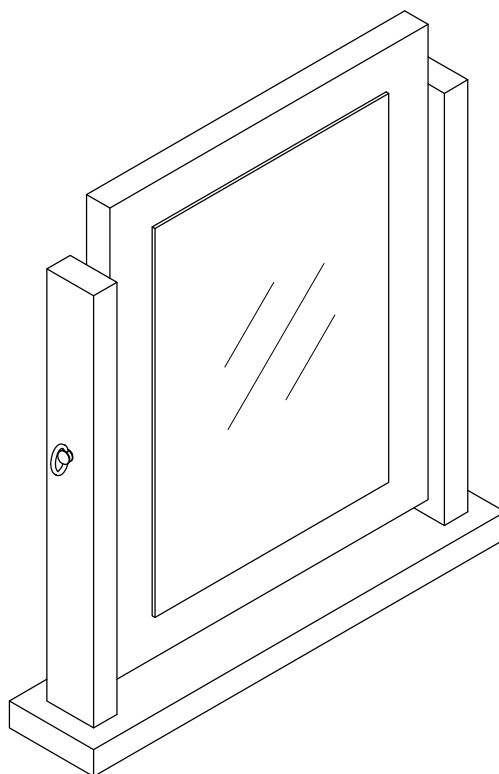

<p style="text-align: center;"><b>INFORMATIONS IMPORTANTES (FRENCH)</b></p> <p style="text-align: center;"><b>IMPORTANTE POUR USAGE DOMESTIQUE UNIQUEMENT VEUILLEZ LIRE AVANT DE CONTINUER</b></p> <p>Le produit que vous avez acheté vous offrira de nombreuses années de service si vous suivez les directives pour son assemblage sûr et son entretien et nettoyage périodiques. Montez sur une surface douce et propre. N'utilisez aucun autre outil que ceux indiqués. Les clés ou clés Allen nécessaires sont fournies avec le kit de fixation. En fonction de la fréquence d'utilisation de ce produit, il peut être nécessaire de resserrer les fixations de temps en temps. Cela est tout à fait normal pour tout meuble en kit. Ce produit comprend du verre trempé d'une épaisseur nominale de 8 mm. Si le verre est ébréché ou cassé, remplacez-le par le type décrit ou consultez les détaillants en indiquant les détails du modèle. <b>AVERTISSEMENT</b> La charge maximale sur le dessus ne doit pas dépasser la limite de poids indiquée sur la première page. Ne vous asseyez pas ou ne vous tenez pas debout sur les surfaces en verre. N'utilisez pas le verre comme surface de coupe. Ne frappez pas le verre avec des objets durs ou pointus. Ne placez pas d'objets très chauds ou très froids sur la surface en verre, à moins que des sets de table suffisamment épais ne soient utilisés pour empêcher ces objets d'entrer en contact avec le verre. Pour nettoyer les panneaux en verre, utilisez un chiffon humide ou un cuir avec du liquide vaisselle ou du savon doux si nécessaire. N'utilisez pas de lessive en poudre ou toute autre substance contenant des abrasifs car ceux-ci rayent considérablement le verre. L'utilisation d'outils électriques pour assembler ce produit invalidera toute réclamation et peut endommager ce produit, le rendant dangereux. Conservez ces instructions dans un endroit sûr pour référence ultérieure.</p>	<p style="text-align: center;"><b>INFORMACIÓN IMPORTANTE (SPANISH)</b></p> <p style="text-align: center;"><b>IMPORTANTE SOLO PARA USO DOMÉSTICO LEER ANTES DE CONTINUAR</b></p> <p>El producto que ha adquirido le brindará muchos años de servicio si sigue las pautas para su montaje seguro y su mantenimiento y limpieza periódicos. Ensamble sobre una superficie suave y limpia. No utilice herramientas distintas a las que se muestran. Las llaves inglesas o llaves Allen necesarias se incluyen con el kit de accesorios. Dependiendo de la cantidad de uso que reciba este producto, puede ser necesario apretar las fijaciones de vez en cuando. Esto es completamente normal en cualquier mueble de paquete plano. Este producto incluye vidrio templado con un espesor nominal de 8 mm. Si el vidrio está astillado o roto, reemplácelo con el tipo descrito o, alternativamente, consulte con los minoristas indicando los detalles del modelo. <b>ADVERTENCIA</b> La carga máxima en la parte superior no excede el límite de peso que se muestra en la página principal. No se siente ni se pare sobre superficies de vidrio. No use el vidrio como superficie para cortar. No golpee el vidrio con elementos duros o puntiagudos. No coloque elementos muy calientes o muy fríos sobre la superficie de vidrio a menos que se utilicen manteles individuales lo suficientemente gruesos para evitar que dichos elementos entren en contacto con el vidrio. Para limpiar los paneles de vidrio, utilice un paño húmedo o un paño de cuero con detergente líquido o jabón suave, si es necesario. No utilice detergente en polvo ni ninguna otra sustancia que contenga abrasivos, ya que rayan considerablemente el vidrio. El uso de herramientas eléctricas para ensamblar este producto invalidará cualquier reclamo y puede dañar este producto, haciéndolo inseguro. Guarde estas instrucciones en un lugar seguro para futuras consultas.</p>
<p style="text-align: center;"><b>WICHTIGE INFORMATIONEN (GERMAN)</b></p> <p style="text-align: center;"><b>WICHTIGUR FÜR DEN HAUSHALTSGEBRAUCH BITTE LESEN SIE, BEVOR SIE FORTFAHREN</b></p> <p>Das von Ihnen erworbene Produkt wird Ihnen viele Jahre lang gute Dienste leisten, wenn Sie die Richtlinien für eine sichere Montage und regelmäßige Wartung und Reinigung befolgen. Auf einer weichen, sauberen Oberfläche montieren. Verwenden Sie keine anderen Werkzeuge als die abgebildeten. Alle benötigten Schraubenschlüssel oder Inbusschlüssel sind im Montagesatz enthalten. Je nach Nutzungsintensität dieses Produkts kann es erforderlich sein, die Befestigungen von Zeit zu Zeit festzuziehen. Dies ist bei Möbeln aus dem Bausatz völlig normal. Dieses Produkt enthält gehärtetes Glas mit einer Nennstärke von 8 mm. Wenn das Glas angeschlagen oder zerbrochen ist, ersetzen Sie es bitte durch das beschriebene Glas oder wenden Sie sich alternativ an den Händler und geben Sie die Modelldetails an. <b>WARNUNG</b> Die maximale Belastung oben darf die auf der Titelseite angegebene Gewichtsgrenze nicht überschreiten. Setzen oder stellen Sie sich nicht auf Glasoberflächen. Verwenden Sie Glas nicht als Schneideunterlage. Schlagen Sie nicht mit harten oder sehr kalten Gegenständen auf Glas. Stellen Sie keine sehr heißen oder sehr kalten Gegenstände auf die Glasoberfläche, es sei denn, Sie verwenden ausreichend dicke Tischmatten, um zu verhindern, dass diese Gegenstände mit dem Glas in Berührung kommen. Verwenden Sie zum Reinigen von Glasscheiben ein feuchtes Tuch oder Leder mit Spülmittel oder Schmierseife, falls erforderlich. Verwenden Sie kein Waschpulver oder andere scheuernde Substanzen, da diese das Glas stark zerkratzen. Die Verwendung von Elektrowerkzeugen zur Montage dieses Produkts macht jegliche Ansprüche ungültig und kann das Produkt beschädigen, wodurch es unsicher wird. Bewahren Sie diese Anleitung zum späteren Nachschlagen an einem sicheren Ort auf.</p>	<p style="text-align: center;"><b>INFORMAZIONI IMPORTANTI (ITALIAN)</b></p> <p style="text-align: center;"><b>IMPORTANTE, SOLO PER USO DOMESTICO SI PREGA DI LEGGERE PRIMA DI CONTINUARE OLTRE</b></p> <p>Il prodotto che hai acquistato ti garantirà molti anni di servizio se seguirai le linee guida per il suo montaggio sicuro e la manutenzione e pulizia periodiche. Montare su una superficie morbida e pulita. Non utilizzare utensili diversi da quelli mostrati. Tutte le chiavi inglesi o le chiavi a brugola necessarie sono incluse nel kit di accessori. A seconda della quantità di utilizzo di questo prodotto, potrebbe essere necessario stringere i fissaggi di tanto in tanto. Ciò è del tutto normale per qualsiasi mobile in kit. Questo prodotto include vetro temperato con uno spessore nominale di 8 mm. Se il vetro è scheggiato o rotto, sostituirlo con il tipo descritto o in alternativa consultare i rivenditori indicando i dettagli del modello. <b>AVVERTENZA</b> Il carico massimo sulla parte superiore non deve superare il limite di peso indicato sulla prima pagina. Non sedersi o stare in piedi sulle superfici in vetro. Non utilizzare il vetro come superficie di taglio. Non colpire il vetro con oggetti duri o appuntiti. Non posizionare oggetti molto caldi o molto freddi sulla superficie in vetro a meno che non vengano utilizzati tovagliette adeguatamente spesse per evitare che tali oggetti entrino in contatto con il vetro. Per la pulizia dei pannelli in vetro, utilizzare un panno umido o pelle con detersivo per piatti o sapone delicato, se necessario. Non utilizzare detersivo in polvere o altre sostanze contenenti abrasivi, poiché graffiano notevolmente il vetro. L'uso di utensili elettrici per assemblare questo prodotto invaliderà qualsiasi reclamo e potrebbe danneggiare il prodotto rendendolo non sicuro. Conservare queste istruzioni in un luogo sicuro per riferimento futuro.</p>

**IMPORTANT PLEASE FOLLOW !**

After unpacking the product, keep the original packaging in case you need to return it. Before starting assembly, check that all parts and hardware are included and in good condition. If anything is missing or damaged, contact the supplier or retailer. **Do not use** non-original parts, modify the item or use power tools as this will void the warranty. Study the instructions thoroughly and follow each step carefully before proceeding to the next.

# TESSA DRESSING TABLE STOOL NATURAL OAK EFFECT/BLACK PU ASSEMBLY INSTRUCTIONS



**MAX STOOL  
WEIGHT**

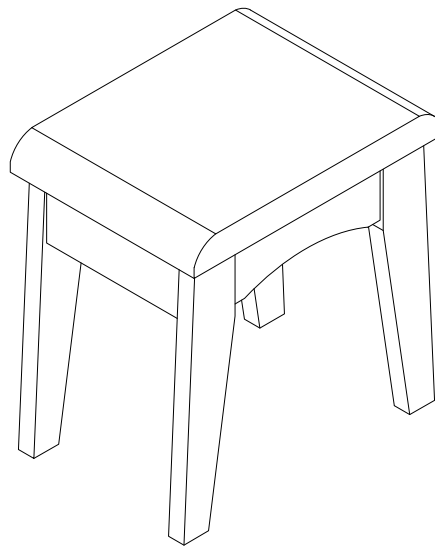

**FOR DOMESTIC USE ONLY  
FURNITURE CARE AND MAINTENANCE  
PLEASE READ BEFORE YOU CONTINUE FURTHER**

### Safety

- Keep children away from the area during assembly for safety.
- Use a blanket or sheet on the floor during assembly to protect both the product and your flooring.
- Follow all recommended weight limits as shown on the assembly instructions.

### Care

- Avoid dragging or pushing the product, as this may damage the joints and weaken the structure.
- Avoid prolonged exposure to direct sunlight, which can cause fading, discolouration, or drying of Leather/PU.
- Maintain stable room temperature and humidity, as extreme heat, cold, or moisture may lead to warping, cracking, or swelling.
- Protect the surface from hot or cold items by using placemat's or coasters.
- Please avoid attaching anything sticky to the item, such as Sellotape, stickers, or similar materials, as this can damage the finish.
- Use felt pads under décor, lamps and accessories to prevent scratches.
- Clean spills immediately, blotting rather than rubbing to prevent spreading and surface damage.

### Maintenance

- Periodically tighten all fittings to ensure the furniture remains stable and secure.
- Wipe with a damp cloth for routine cleaning and use a mild soap solution as needed - avoid using harsh chemicals, alcohol-based products and excessive water.
- Please clean with a dry soft cloth to remove dust, crumbs and pet hair.
- Apply leather conditioner every 6-12 months to keep leather supple.

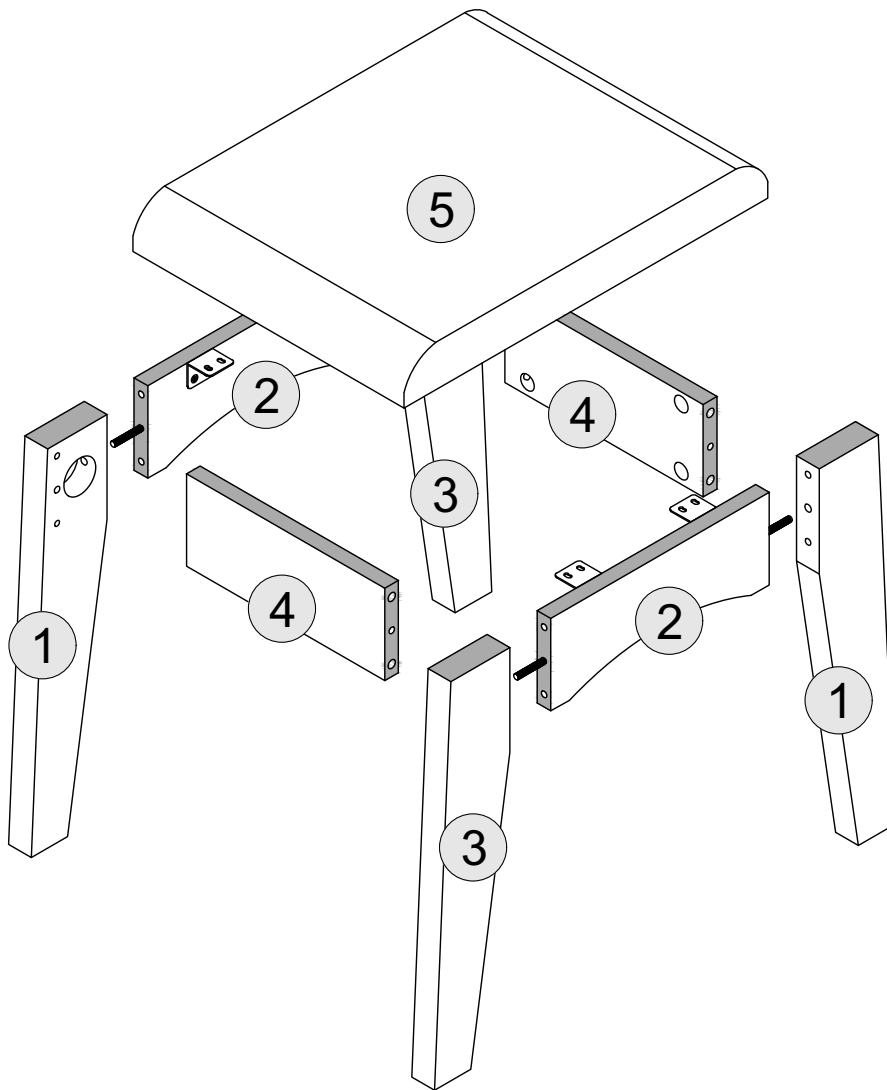

## PART LIST

<u>Part Number</u>	<u>Part Code</u>	<u>Part Description</u>	<u>Quantity</u>	<u>Carton</u>
1	S100-107-025-EU1-01S	Leg - Right	2	1/1
2	S100-107-025-EU1-02S	Support Bar	2	1/1
3	S100-107-025-EU1-03S	Leg - Left	2	1/1
4	S100-107-025-EU1-04S	Side Support Bar	2	1/1
5	S100-107-025-EU1-05S	Cushion	1	1/1

## HARDWARE LIST

A		DOWEL 6 X 30MM	12 PCS
B		CAM BOLT + CAM NUT	8 SETS
C		PLASTIC FOOT	4 PCS
D		SCREW M3.5 X 16MM	8 PCS
E		SPANNER	1 PC
F		FLANGE NUT	4 PCS

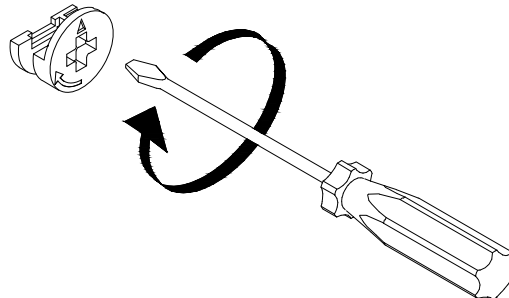

(SCREWDRIVER NOT PROVIDED)

USE A FLAT HEAD SCREWDRIVER TO TIGHTEN THE CAM NUTS. A QUARTER TURN CLOCKWISE IS ALL THAT IS NEEDED.

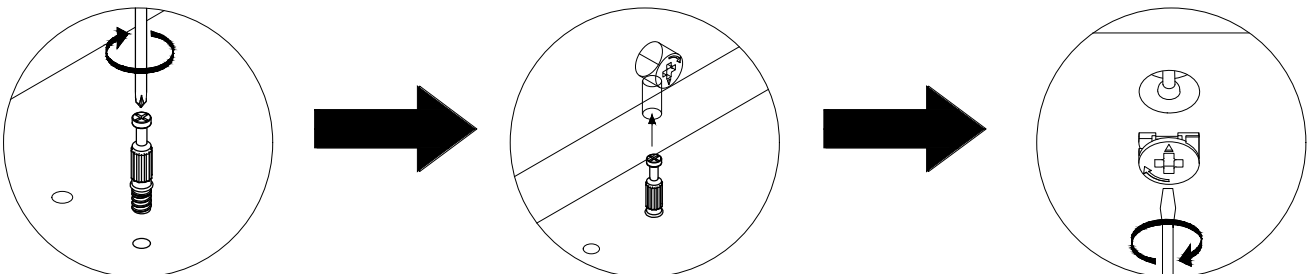

STEP 1 - USE A CROSS SLOT SCREWDRIVER TO TIGHTEN THE CAM BOLT INTO THE HOLE.

STEP 2 - ALIGN THE CAM BOLT WITH THE HOLE AND PUSH TOGETHER UNTIL FLUSH. ( MAKE SURE THE ARROW OF THE CAM LOCK IS POINTING TOWARD ON THE EDGE OF THE PANEL.)

STEP 3 - THE HEAD OF THE BOLT GOES INTO THE WIDE MOUTH OF THE CAM LOCK. YOU THEN TURN THE LOCK SO THE NARROW PART CLOSES OVER THE BOLT.

# STEP 1

PARTS REQUIRED

1 - LEG - RIGHT x2

3 - LEG - LEFT x2

HARDWARE REQUIRED

B  08

C  04

TOOLS REQUIRED

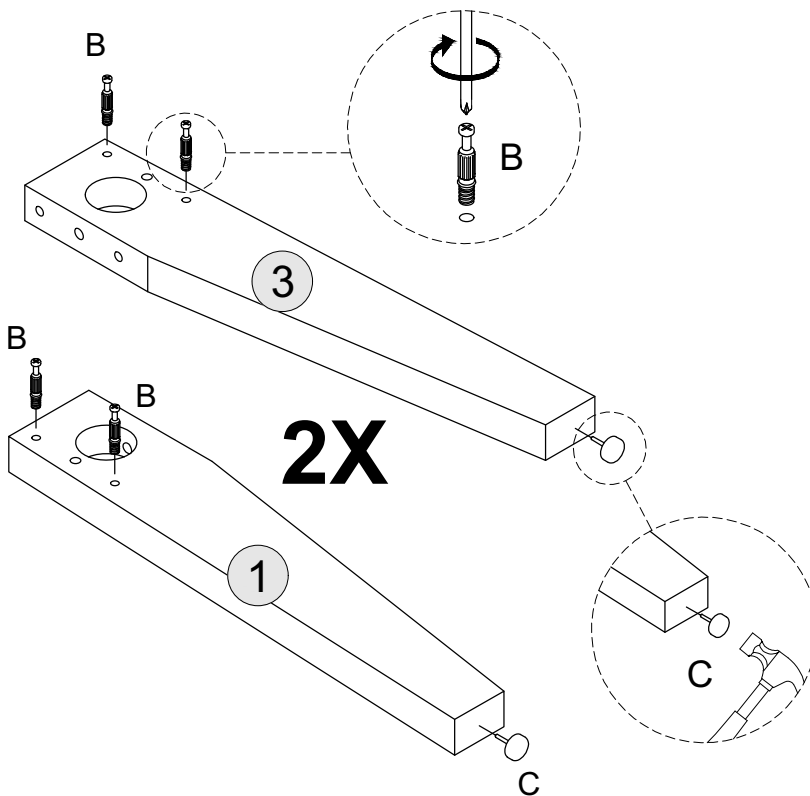
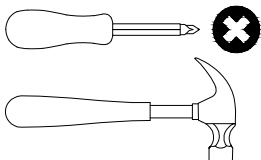

# STEP 2

PARTS REQUIRED

2 - SUPPORT STOOL x2

HARDWARE REQUIRED

A  08

TOOLS REQUIRED

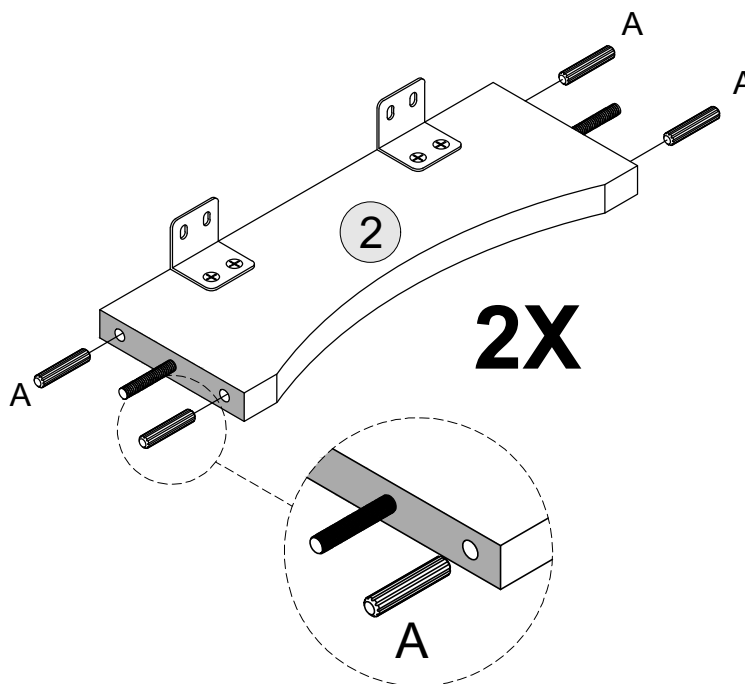
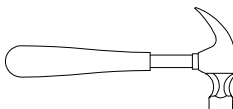

# STEP 3

PARTS REQUIRED

4 - SIDE SUPPORT STOOL x2

HARDWARE REQUIRED

A  04

B  08

TOOLS REQUIRED

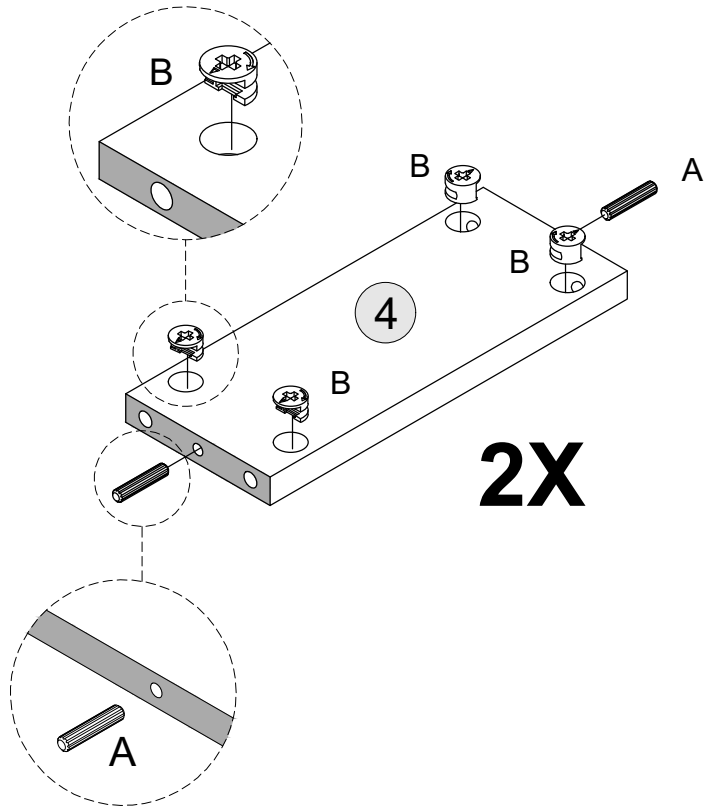
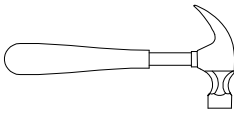

# STEP 4

PARTS REQUIRED

1 - LEG - RIGHT x2

2 - SUPPORT STOOL x2

3 - LEG - LEFT x2

HARDWARE REQUIRED

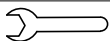
E  01

F  04

TOOLS REQUIRED

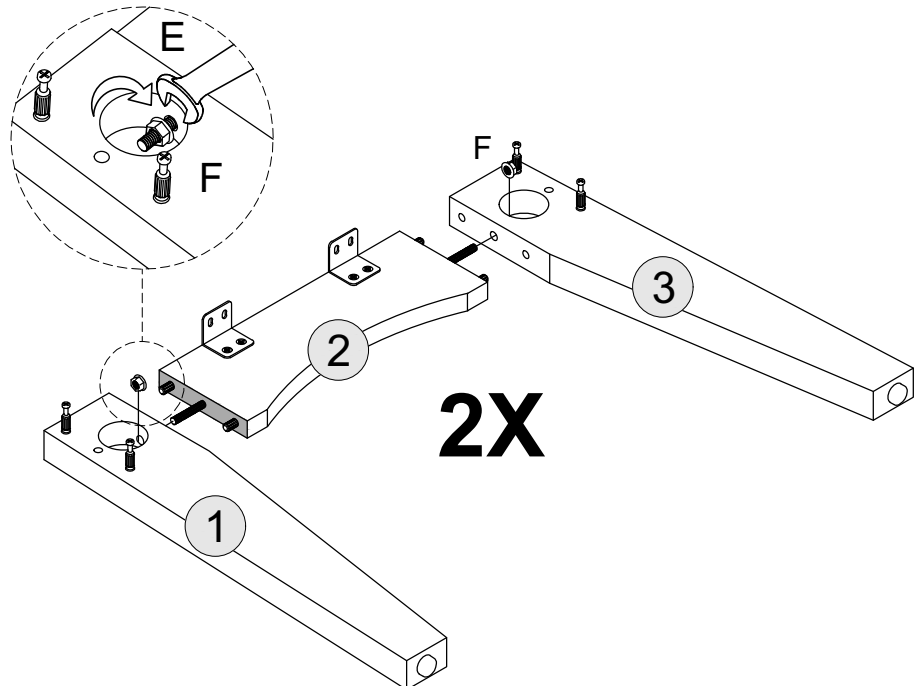

# STEP 5

PARTS REQUIRED

4 - SIDE SUPPORT STOOL x2

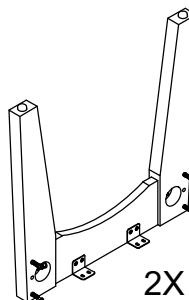

HARDWARE REQUIRED

TOOLS REQUIRED

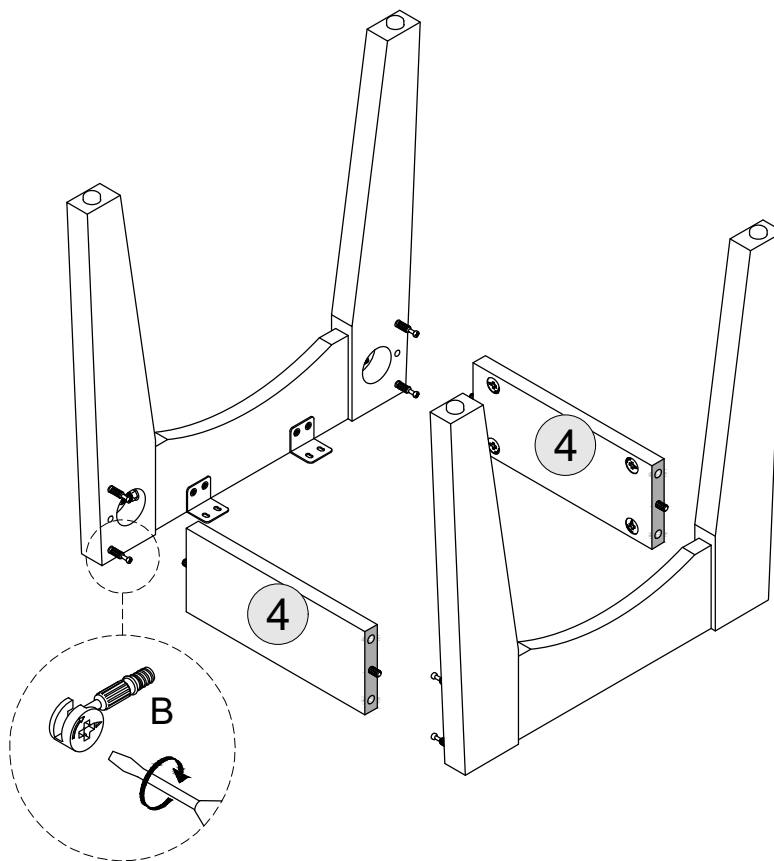
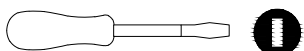

# STEP 6

PARTS REQUIRED

5 - CUSHION x1

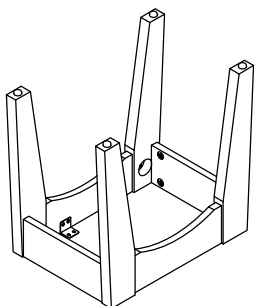

HARDWARE REQUIRED

D  08

TOOLS REQUIRED

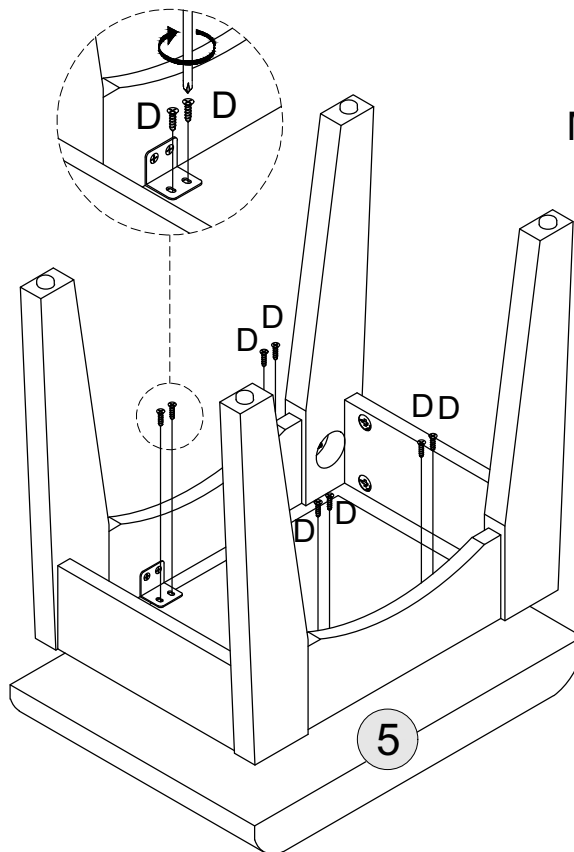
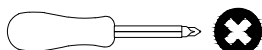

**100KG**  
MAX STOOL  
WEIGHT

**INFORMATIONS IMPORTANTES (FRENCH)****IMPORTANTE  
POUR USAGE DOMESTIQUE UNIQUEMENT  
VEUILLEZ LIRE AVANT DE CONTINUER**

Le produit que vous avez acheté vous offrira de nombreuses années de service si vous suivez les directives pour son assemblage sûr et son entretien et nettoyage périodiques.

Montez sur une surface douce et propre.

N'utilisez aucun autre outil que ceux indiqués.

Toutes les clés ou clés Allen nécessaires sont fournies avec le kit de fixation.

N'utilisez en aucun cas un outil électrique pour assembler ce produit.

Son utilisation invalidera et pourrait rendre ce produit dangereux.

En fonction de la quantité d'utilisation de ce produit, il peut être nécessaire de resserrer les fixations de temps en temps. Cela est tout à fait normal pour tout meuble en kit.

Pour le nettoyage, vous pouvez utiliser un chiffon humide (pas mouillé).

N'utilisez pas de détergent à polir ou de nettoyeurs chimiques.

Ce produit peut tacher ou marquer s'il entre en contact avec des objets mouillés ou humides.

La surface de cet article n'est pas résistante à la chaleur, utilisez toujours un set de table sous les articles chauds ou froids pour éviter les marques.

**INFORMACIÓN IMPORTANTE (SPANISH)****IMPORTANTE  
SOLO PARA USO DOMÉSTICO  
LEER ANTES DE CONTINUAR**

El producto que ha adquirido le brindará muchos años de servicio si sigue las pautas para su montaje seguro y su mantenimiento y limpieza periódicos.

Ensamble sobre una superficie suave y limpia.

No utilice ninguna herramienta que no sea la que se muestra.

Las llaves inglesas o llaves Allen necesarias están incluidas con el kit de accesorios.

No utilice bajo ningún concepto una herramienta eléctrica para ensamblar este producto. Su uso invalidará cualquier reclamación que pueda tener y podría hacer que este producto sea inseguro.

Dependiendo de la cantidad de uso que reciba este producto, puede ser necesario ajustar las fijaciones de vez en cuando. Esto es completamente normal en cualquier mueble de paquete plano.

Para la limpieza, puede utilizar un paño húmedo (no mojado). No utilice detergentes abrillantadores ni limpiadores químicos.

Este producto puede mancharse o marcarse si se deja en contacto con objetos mojados o húmedos.

La superficie de este artículo no es resistente al calor, utilice siempre un mantel individual debajo de los elementos calientes o fríos para evitar marcas.

**WICHTIGE INFORMATIONEN (GERMAN)****WICHTIG!  
FÜR DEN HAUSHALTSGEBRAUCH  
BITTE LESEN SIE, BEVOR SIE FORTFAHREN**

Das von Ihnen erworbene Produkt wird Ihnen viele Jahre lang gute Dienste leisten, wenn Sie die Richtlinien für eine sichere Montage und regelmäßige Wartung und Reinigung befolgen.

Auf einer weichen, sauberen Oberfläche montieren.

Verwenden Sie keine anderen Werkzeuge als die abgebildeten.

Alle benötigten Schraubenschlüssel oder Inbusschlüssel sind im Montagesatz enthalten.

Verwenden Sie unter keinen Umständen ein Elektrowerkzeug zur Montage dieses Produkts. Bei Verwendung erlischt Ihr Anspruch und das Produkt kann unsicher werden.

Je nach Nutzungsintensität des Produkts kann es von Zeit zu Zeit erforderlich sein, die Befestigungen festzuziehen. Dies ist bei Möbeln aus dem Bausatz völlig normal.

Zum Reinigen können Sie ein feuchtes Tuch verwenden (nicht nass).

Verwenden Sie kein Poliermittel oder chemische Reinigungsmittel.

Dieses Produkt kann Flecken oder Abdrücke hinterlassen, wenn es mit nassen oder feuchten Gegenständen in Kontakt kommt.

Die Oberfläche dieses Artikels ist nicht hitzebeständig. Verwenden Sie immer eine Unterlage unter heißen oder kalten Gegenständen, um Abdrücke zu vermeiden.

**INFORMAZIONI IMPORTANTI (ITALIAN)****IMPORTANTE, SOLO PER USO DOMESTICO  
SI PREGA DI LEGGERE PRIMA DI  
CONTINUARE OLTRE**

Il prodotto che hai acquistato ti garantirà molti anni di servizio se seguirai le linee guida per il suo montaggio sicuro e la manutenzione e pulizia periodiche.

Montare su una superficie morbida e pulita.

Non utilizzare utensili diversi da quelli mostrati.

Tutte le chiavi inglesi o le chiavi a brugola necessarie sono incluse nel kit di raccordi.

Non utilizzare per nessun motivo un elettroutensile per montare questo prodotto. Il suo utilizzo invaliderà e affermerà che potresti avere e potrebbe rendere questo prodotto non sicuro.

A seconda della quantità di utilizzo di questo prodotto, potrebbe essere necessario stringere i fissaggi di tanto in tanto. Ciò è del tutto normale per qualsiasi mobile in kit.

Per la pulizia, puoi utilizzare un panno umido (non bagnato). Non utilizzare detergenti lucidanti o detergenti chimici.

Questo prodotto potrebbe macchiare o segnare se lasciato entrare in contatto con oggetti bagnati o umidi.

La superficie di questo articolo non è resistente al calore, utilizzare sempre un sottopiatto sotto gli oggetti caldi o freddi per evitare segni.